

cookworks

Single Hotplate

Model No. JB- 3228GL



Care & Instruction Manual

For household and indoor use only

Please read these instructions before use and retain for future reference



ELECTRICAL SAFETY

- You should only plug the appliance into a 220V-240V AC, 50Hz supply. Connecting it to other power sources may damage the appliance and will invalidate the guarantee.
- Switch off and unplug when not in use and before cleaning the appliance.
- Keep the appliance and its cord out of reach of children less than 8 years.
- Do not allow children to use the appliance without supervision.
- This appliance can be used by children aged from 8 years and above and persons with reduced physical, sensory or mental capabilities or lack of experience and knowledge if they have been given supervision or instruction concerning use of the appliance in a safe way and understand the hazards involved. Children shall not play with the appliance. Cleaning and user maintenance shall not be made by children unless they are older than 8 and supervised.
- Keep cable, plug and appliance dry and away from areas where it is likely to get splashed. Never immerse in water. Never clean with a steam cleaner.
- Do not pull on the cable to disconnect from mains supply.
- Do not operate the appliance if damaged or after it malfunctions. In the event the supply cord is damaged, in order to avoid a hazard it must only be replaced by a qualified service engineer, with a suitably approved part.
- This appliance must be positioned so that the plug is accessible and the plug socket is within easy reach of the power cord.
- This appliance must be plugged into an earthed socket outlet.

WARNING!

- This appliance is intended exclusively for use in domestic households. It is not suitable for commercial use.
-  The surfaces of the hotplate and the containers used on it will become hot during and immediately after use; wear oven gloves when handling. Note the hotplate is subject to residual heat after use. Do not touch.
- Unattended cooking on a hob with fat or oil can be dangerous and may result in fire. NEVER try to extinguish a fire with water, but switch off the appliance and then cover the flame e.g. with a lid or fire blanket.
- Danger of fire; do not store items on the cooking surfaces.
- Do not use the hotplate on, near or under flammable or heat sensitive items.
- CAUTION: The cooking process has to be supervised. A short term cooking process has to be supervised continuously.
- Do not cover and allow the hotplate to cool fully before storing.
- Do not operate the hotplate using a timer or separate remote control.
- Do not use an extension cord with this appliance.
- Only use for intended purpose - cooking food for short intervals (e.g. less than one hour). This appliance can cause personal injury if misused.
- Always place food to be cooked into a pan. NEVER cook food directly on the hotplate.
- **NEVER lift the hotplate by the handles when it is in use or when there is cookware on the hotplate.**

FOOD SAFETY

- Thoroughly defrost frozen meat, poultry, fish and seafood in the refrigerator before cooking unless cooking from frozen advice is provided by the food packaging.
- Keep raw meat and poultry separate from cooked foods.
- Always wash hands after handling raw meat and poultry, before handling any ready to eat foods.
- Wipe and disinfect surfaces that have been in contact with raw meat and poultry.
- Use separate utensils for handling raw meat/poultry and cooked food or wash them thoroughly between use.
- To check whether meat, particularly poultry, is cooked, pierce the flesh with a skewer or fork; the juices should run clear. Ensure the product is piping hot throughout.
- Fish is cooked when it appears opaque and can be flaked easily.

PARTS

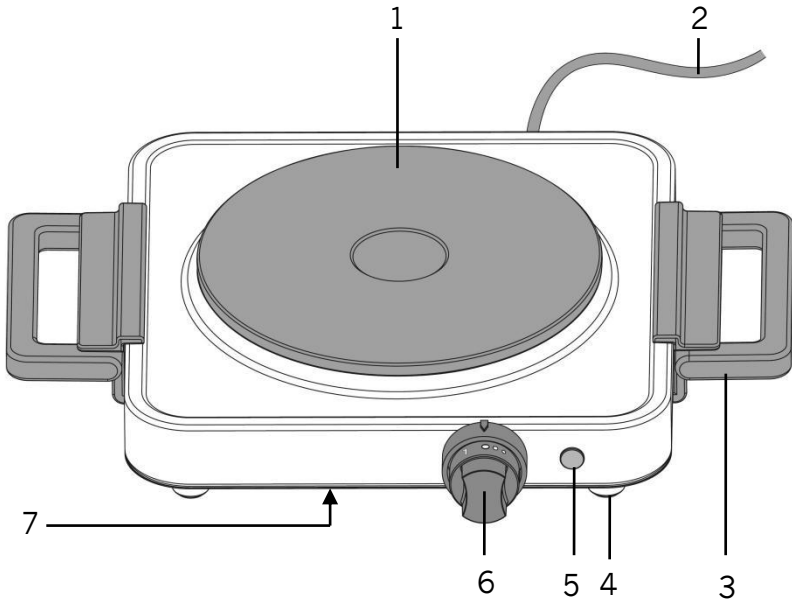

1. Hotplate
2. Power cable
3. Handle

4. Feet
5. Hotplate
indicator

6. Temperature
control knob
7. Air vents

TIPS FOR SUCCESSFUL COOKING

- Follow cooking instructions on food packaging.
- Turn or stir some foods halfway through cooking process.
- The cooking time will vary according to the shape, thickness and composition of the food.
- Smaller pieces will cook quicker than larger pieces. For best results, ensure pieces of food are similar in size and thickness.

HOTPLATE USE

The hotplate can be used in a similar manner to conventional electric oven hobs to fry and boil food. The hotplate is suitable for pans up to a maximum of 18cm and 3litre capacity and should be used for cooking intervals of less than one hour.

1. Unpack and dispose of all packaging safely.
2. Place the hotplate on a stable, flat, heat resistant surface and away from any flammable materials. Check that the control knob is in the off (0) position.
3. Fully unwind the cable and plug in. For safety do not allow the cable to dangle over the edge of units.
4. Turn the control knob and select the desired hotplate power. 1 is the lowest setting suitable for keeping a pot at a simmer. 5 is the highest setting suitable for use when bringing a pot to a boil or when using a large pan.
5. The hotplate indicator will **illuminate** when the hotplate is in heating mode and **extinguish** when it has reached the desired temperature. It is usual for the indicator to switch on and off during the hotplate use.
6. Place the food into a vessel suitable for an electric hob and fry or cook as required by your recipe.
7. To switch off the hotplate, turning the control knob to the off (0) position or switch off at the mains. The hotplate indicator will extinguish.

Notes:

- Some smoke or odour may be emitted when the hotplate is first used. To eliminate any manufacturing residues, open the room window, place a saucepan of water on the hotplate and operate at the maximum setting for 10 minutes. Clean the hotplate in accordance with the cleaning section of these instructions.
- Some discolouration of the paint surrounding the hob may occur after prolonged use. This is normal and is due to the high temperature generated by the hob and may be exacerbated by using oversized pans.

TIPS FOR EFFICIENT HOB USE

- Do not operate the hob for an extended time without a pan on the hotplate (fig. 1).



- Use pans with flat bottoms (fig. 2). Uneven or thin bottomed pans will waste energy, are slow to cook, can rock and overbalance.

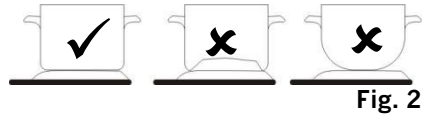

- Use pans that are the same size or slightly larger than the hotplate (fig. 3). Smaller pans waste energy and oversized pans (>18cm) can overheat the hob and cause cracks and damage.

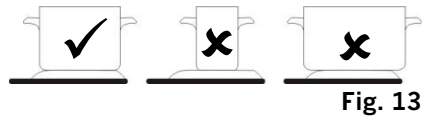

- Ensure the pan base is dry and avoid placing wet lids on hotplates (fig. 4).

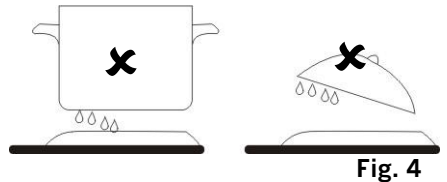

CLEANING

Clean the hotplate after each use.

- Switch off and unplug the hotplate and allow it to cool completely.
- After the hotplate is cooled completely, wipe surfaces of the hotplate with a soft damp cloth and dry surfaces with a soft dry cloth.
- Do not use strong detergents or abrasives, as these may dull or scratch the surface. Do not immerse in water. Do not use a steam cleaner.

TECHNICAL SPECIFICATION

Cookworks Single hotplate	
Model	JB-3228GL
Rated Voltage & Frequency	220 - 240V ~ 50-60Hz
Rated Power Input	1500W
Class rating	1 (earthed)
BS 1362 fuse	10A
Product dimensions (external)	29.5 x 28.5 x 7.2 cm (handle folded) 35.7 x 28.5 x 7.2 cm (handle unfolded)
Product weight (net)	2.3 kg approx.

Complies with EU directive 2009/125/EC – Reg.No 66/2014	
Type of hob	Electrical
Number of cooking zones	1
Heating technology	Solid Plate
Cooking zone diameter (Ø)	18.5 cm
Energy consumption per cooking zone $EC_{\text{electric cooking}}$	193.6 Wh/kg
Energy consumption for the hob $EC_{\text{electric hob}}$	193.6 Wh/kg
Test Method: EN 60350-2:2018. Household electric cooking appliances - Part 2: Hobs - Methods for measuring performance	



RECYCLING ELECTRICAL PRODUCTS

You should now recycle your waste electrical goods and in doing so help the environment.

This symbol means an electrical product should not be disposed of with normal household waste. Please ensure it is taken to a suitable facility for disposal when finished with.

Visit www.recycle-more.co.uk, click on “bank locator” and enter your postcode to find your nearest recycling site.



PLUG / WIRING ADVICE

The wires in this mains lead are coloured in accordance with the following UK electrical code:

BLUE = NEUTRAL

BROWN = LIVE

GREEN + YELLOW = EARTH

Non-rewireable plug

This appliance may be fitted with a “non-rewireable” plug. If you need to change the fuse in a “non-rewireable” plug, the fuse cover must be refitted. If the fuse cover is lost or damaged, the appliance must not be used.

Rewireable plug

The colours of the wires in the mains lead of this appliance may not correspond with the coloured markings identifying the terminals in a rewireable plug. **Rewireable plugs should only be replaced by a suitably competent person. If in doubt, consult a qualified electrician.**

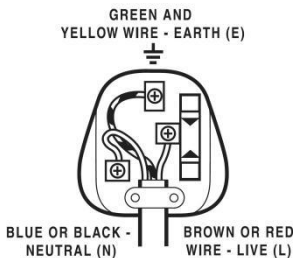

The BLUE wire must be connected to the terminal marked with the letter N

The BROWN wire must be connected to the terminal marked with the letter L

The GREEN & YELLOW wire must be connecting to the terminal marked with the letter E or the earth symbol .

Produced in China.

Argos Limited, 489-499 Avebury Boulevard,
Milton Keynes, MK9 2NW.

Argos (N.I.) Ltd, Forestside Shopping Centre,
Upper Galwally, Belfast, United Kingdom, BT8
6FX.

Argos Distributors (Ireland) Limited, Unit 7,
Ashbourne Retail Park, Ballybin Road,
Ashbourne, County Meath, Ireland

www.argos.co.uk/cookworks

Tel: 0345 640 3030



PRODUCT GUARANTEE

This product is guaranteed against manufacturing defects for a period of



Year

This product is guaranteed for twelve months from the date of original purchase.

Any defect that arises due to faulty materials or workmanship will either be replaced, refunded or repaired free of charge where possible during this period by the dealer from whom you purchased the unit.

The guarantee is subject to the following provisions:

- The guarantee does not cover accidental damage, misuse, cabinet parts, knobs or consumable items.
- The product must be correctly installed and operated in accordance with the instructions contained in this manual. A replacement copy of this instruction manual can be obtained from www.argos-support.co.uk
- It must be used solely for domestic purpose.
- The guarantee will be rendered invalid if the product is re-sold or has been damaged by inexpert repair.
- Specifications are subject to change without notice.
- The manufacturer disclaims any liability for the incidental or consequential damages.
- The guarantee is in addition to, and does not diminish your statutory or legal rights.

Guarantor: Argos Ltd
489 - 499 Avebury Boulevard
Central Milton Keynes
MK9 2NW
www.argos-support.co.uk