

TOOMAX[®]

STORA WAY PLUS 2XL

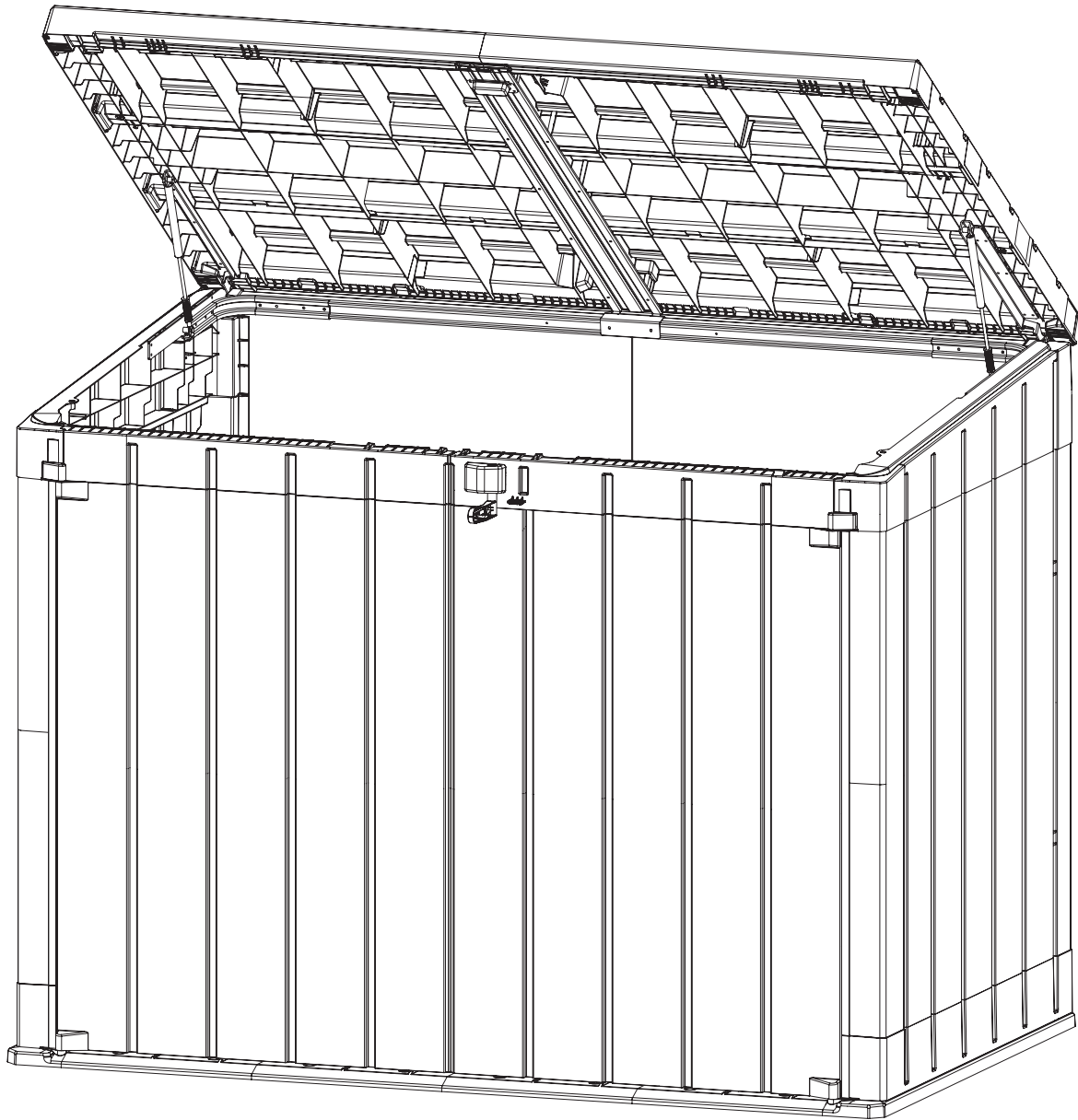

Art. 105 cm 178x109x140h | in 70,1x42,9x55,1h

STORA WAY PLUS 2XL

Art. 105 cm 178x109x140h | in 70,1x42,9x55,1h

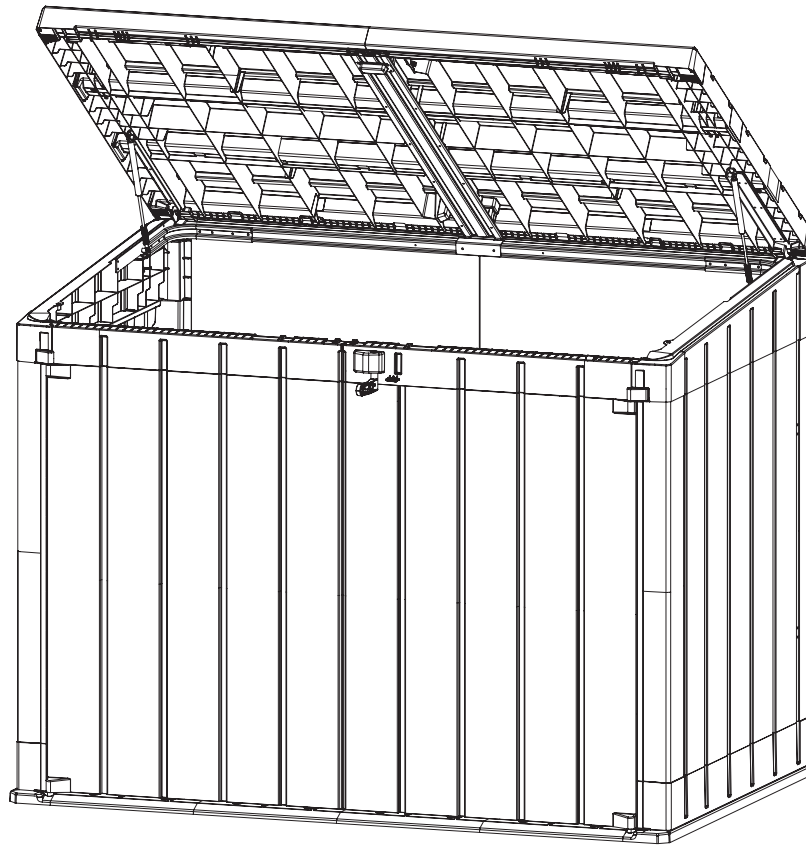

IT: Per interni ed esterni
EN: Suitable for indoor and outdoor



IT: Attrezzi necessari
EN: Tools required



IT: Predisposizione per lucchetto
EN: Lockable



IT: Apertura/chiusura assistita
del coperchio
EN: Assisted opening/closing of the lid



IT: 2 persone per il montaggio
EN: 2 persons for assembly



IT: Anta con chiusura a battente
EN: Door with leading edge



IT: Volume di 2270 L
EN: Volumen of 600 gal



IT: Resistente ai raggi UV
EN: UV resistant

PRIMA DI INIZIARE L'ASSEMBLAGGIO / BEFORE STARTING ASSEMBLY

IT:

1. In caso di pezzi mancanti o danneggiati all'interno del cartone, rivolgersi al punto vendita presentando la prova di acquisto. Indicare sempre il codice dei pezzi mancanti o danneggiati, indicati alla sezione "ISTRUZIONI DI MONTAGGIO" di questo manuale.
2. Dopo aver livellato la superficie del terreno con appositi attrezzi da lavoro, si raccomanda di fissare il prodotto ancorandolo al suolo tramite i fori oppure al muro tramite viti adeguate (le viti non sono incluse).
3. La confezione contiene alcuni componenti metallici taglienti o appuntiti; si raccomanda di indossare guanti da lavoro durante il montaggio del prodotto.
4. A causa di variazioni nella produzione, la dimensione effettiva del prodotto assemblato può variare leggermente dalle dimensioni menzionate.

EN:

1. If parts are missing or damaged, please contact your local dealer accompanied by the proof of purchase. Remember to indicate the code of missing or damaged parts always referring to this manual.
2. After levelling the surface or onto the wall, it is mandatory to anchor the product to the ground by drilling holes in the product floor after levelling the surface or onto the wall, using proper screws (screws are not provided).
3. The pack may contain some metallic sharp parts. Please be careful when handling these components. Always wear work gloves.
4. Due to variations, the actual assembled size may vary slightly from the specified dimensions.

ATTREZZATURA OCCORRENTE PER IL MONTAGGIO / REQUIRED TOOLS

IT: Attrezzatura non inclusa! **EN: Tools not included!**

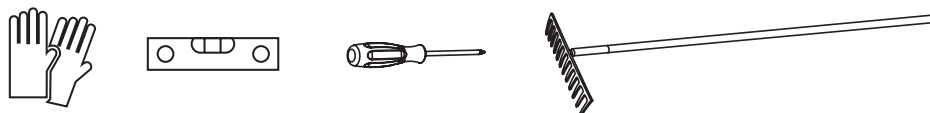

GARANZIA LIMITATA DI 2 ANNI / 2 YEAR LIMITED WARRANTY

IT: L'intera gamma dei prodotti viene prodotta con materiali di qualità e sotto controllo rigoroso. Qualora si presentasse un problema, rivolgersi al punto vendita presso cui è stato acquistato il prodotto.

Plastmeccanica S.p.A. sottopone i propri prodotti a test di resistenza e di stabilità ed è pronta a sostituire, a propria discrezione, qualsiasi prodotto o parti di esso qualora sia presente un difetto strutturale o produttivo per un periodo di 2 anni a partire dalla data di acquisto. Il periodo della garanzia inizia a partire dalla data di acquisto, quindi è necessario conservare la prova di acquisto da poter presentare su richiesta.

Dopo aver presentato un reclamo, il periodo di garanzia continuerà ad essere calcolato e resterà valido fino alla data della sua scadenza.

Sono esclusi dalla presente garanzia: danni causati da uso di forza, utilizzo non corretto o inappropriato, negligenza, uso commerciale o diverso da quello personale o domestico, danni derivanti da alterazione, pittura o assemblaggio non eseguito in conformità alle istruzioni di montaggio, danni causati dagli effetti di condizioni meteorologiche eccezionali (inclusi ma non limitati a temporali).

Plastmeccanica S.p.A. non si riterrà responsabile di eventuali danni causati ai beni riposti all'interno del prodotto.

EN: The full range of products is made with high quality materials and under strict controls. In case a problem should occur, please address your claim to the dealer where you purchased the product.

Plastmeccanica S.p.A. always tests its products for durability and stability and shall replace, at its discretion, any product or part which fails due to structural defect or faulty workmanship for a 2-year period from the date of purchase. The warranty period shall begin on the date of purchase; you should therefore keep the dated receipt to present upon request.

After a claim has been settled, the warranty period will continue to be counted and shall terminate upon its expiry date.

Damages caused by use of force, incorrect handling, inappropriate use, neglect, commercial use or use other than for personal or domestic purposes, damages resulting from alteration, painting or assembly not in accordance with the instruction manual and damages caused as a result of overload are excluded from warranty. In addition, the warranty excludes any damage coming from exceptional weather condition effects (including but not limited to storms).

Lastly, Plastmeccanica S.p.A shall not be responsible for any damage to goods stored inside the product.

MANUTENZIONE E SICUREZZA / CARE AND SAFETY

IT:

- Il prodotto è destinato esclusivamente a contenere oggetti; non è stato progettato per essere utilizzato come abitazione.
- È fondamentale assemblare tutte le parti seguendo accuratamente le istruzioni nella sequenza indicata, senza saltare alcun passaggio e con l'ausilio degli attrezzi indicati.
- Per la scelta del luogo di posizionamento tenere conto della direzione del vento, che può danneggiare il prodotto, in modo particolare le ante. Quando il prodotto non è in uso, tenere il prodotto chiuso per evitare danni.
- Durante il montaggio, indossare sempre guanti da lavoro e prestare attenzione alle parti taglienti o appuntite.
- Al termine del montaggio, smaltire gli imballaggi secondo la vigente normativa sulla raccolta dei rifiuti.
- Temperatura di esercizio: -5/+40° C
- Il prodotto non può essere usato per trasportare cose e/o persone.
- Evitare di eseguire il montaggio durante le giornate ventose e/o piovose.
- Pulire con acqua e saponi neutri, non aggressivi. Non usare spazzole dure né detergenti abrasivi. Evitare detergenti a base di oli e acetoni.
- Dopo la pioggia, asciugare sempre il prodotto con un panno asciutto.
- Evitare di urtare il prodotto con oggetti che potrebbero danneggiarlo.
- Controllare periodicamente che il prodotto sia stabile e sicuro.
- Non riporre sostanze chimiche infiammabili o corrosive.
- Non riporre oggetti caldi (ad esempio, grill o altre attrezzature incandescenti).
- Non idoneo per riporre alimenti.
- In caso di incendio, non usare l'acqua per spegnere il fuoco sugli oggetti in polipropilene.
- Non salire né sedersi sul coperchio.
- Non chiudere persone e/o animali all'interno del prodotto.
- Si raccomanda di fare attenzione alla chiusura delle ante, specialmente in presenza di bambini.
- Questo prodotto non è un giocattolo. Non permettere ai bambini di entrare all'interno.
- Conservare il presente manuale per future referenze.
- A fine vita, smaltire il prodotto secondo la vigente normativa sulla raccolta dei rifiuti.
- Consultare le autorità locali per verificare se sono necessari dei permessi per assemblare il prodotto.

EN:

- *This product is intended for storage use only. It is not designed to be used as habitation.*
- *It is crucial to assemble all the parts according to the instructions using tools listed in the manual. Do not omit any step.*
- *Take into consideration the wind direction when selecting the placement of the product. In any case, reduce the exposure to the wind as much as possible. Keep doors closed and locked when the product is not in use to prevent such damage.*
- *Always wear work gloves and be careful when handling sharp or pointed parts.*
- *After installation, dispose of packaging in accordance with the local regulations.*
- *Working temperature: -5/+40° C.*
- *Not designed to carry items and/or people.*

- *Do not attempt assembly on windy or cold days.*
- *Wash with water and mild detergent solution to avoid any damage to the plastic surface. Avoid using oil or acetone-based cleaners. Do not use stiff brushes or abrasive cleaners.*
- *After the rain, wipe with dry cloth.*
- *Do not hit the product with blunt objects.*
- *Periodically inspect the product is stable and safe.*
- *Not suitable for storing flammable or corrosive substances.*
- *Never store hot items in the box (such as recently used grills, blowtorches, irons, etc.).*
- *Not suitable for storing foods.*
- *In case of fire, do not attempt to extinguish burning polypropylene with water.*
- *Do not shut people or animals in the product.*
- *Be careful when closing the doors to avoid getting stuck with your hands, especially in the presence of children.*
- *The product is not a toy. To prevent risk of suffocation, do not allow children to play inside the product.*
- *Keep the manual for future reference.*
- *At the end of its useful life, dispose of the product in accordance with the local regulations.*
- *Consult your local authorities to check if permits are required to erect the shed.*





AVVERTENZE SULLE MOLLE A GAS / WARNINGS REGARDING GAS SPRINGS



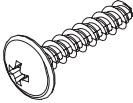

IT:

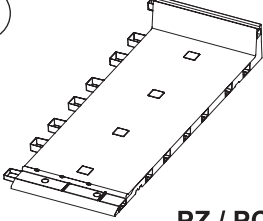
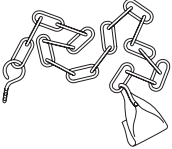
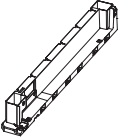
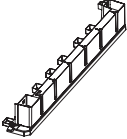
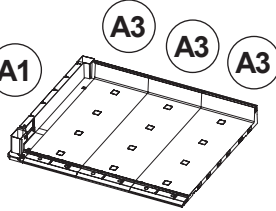
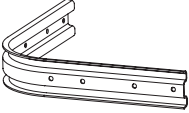
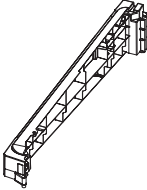
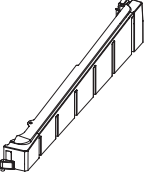
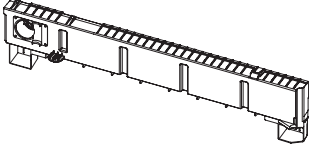
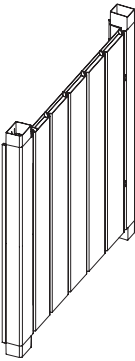
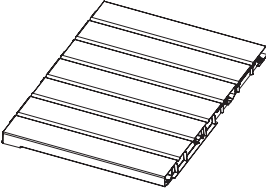
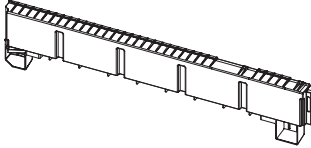
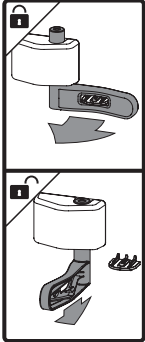
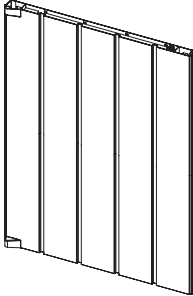
- Non tentare di aprire, perforare o modificare.
- Non posizionare vicino a fonti di calore.
- Non danneggiare l'asta. Non deve essere intaccata da corpi contundenti o abrasivi o da eventuali sostanze chimiche corrosive, vernici, oli o simili.
- Non lubrificare l'asta.
- Non installare se visibilmente danneggiata.
- Non applicare forze laterali.

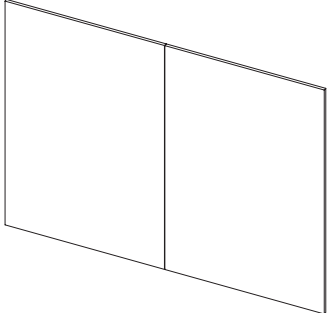
EN:

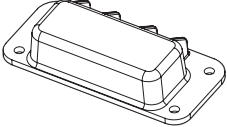
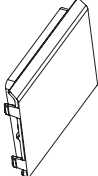
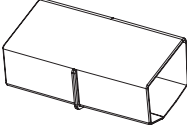
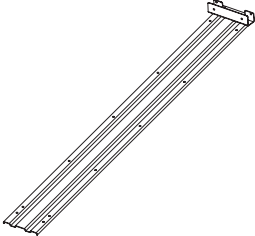
- *Do not try to open, pierce or modify.*
- *Do not place near heating sources.*
- *Do not damage the gas spring rod. It shall not be hit by blunt or abrasive objects or any corrosive substance, paint, oil or similar.*
- *Do not lubricate the gas spring rod.*
- *Do not assemble if clearly damaged.*
- *Do not apply lateral forces.*

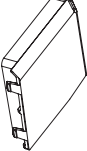
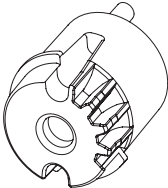
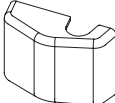
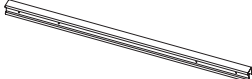
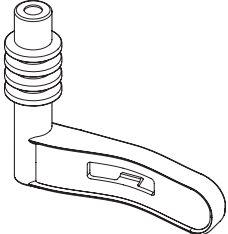
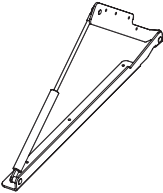
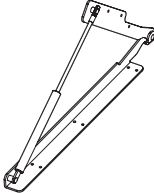
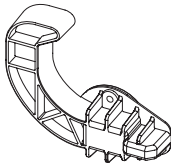
<p>Y</p>  <p>PZ / PCS 64</p>	<p>V</p>  <p>PZ / PCS 4</p>	<p>A3</p>  <p>PZ / PCS 1</p>	 <p>PZ / PCS 2</p>
<p>A1</p>  <p>PZ / PCS 1</p>	<p>A2</p>  <p>PZ / PCS 1</p>	<p>A1 A3 A3 A3</p>  <p>PZ / PCS 1</p>	<p>W</p>  <p>PZ / PCS 4</p>
<p>F</p>  <p>PZ / PCS 1</p>	<p>G</p>  <p>PZ / PCS 1</p>	<p>L</p>  <p>PZ / PCS 1</p>	
<p>B</p>  <p>PZ / PCS 2</p>	<p>K1</p>  <p>PZ / PCS 2</p>	<p>I</p> 	 <p>PZ / PCS 1</p>
<p>C</p>  <p>PZ / PCS 2</p>	<p>T</p>  <p>PZ / PCS 3</p>	<p>X</p>  <p>PZ / PCS 1</p>	

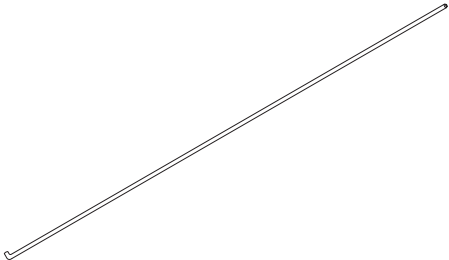
<p>S</p>  <p>PZ / PCS 1</p>	<p>Z2</p>  <p>PZ / PCS 4</p>	<p>K2</p>  <p>PZ / PCS 4</p>
<p>K4</p>  <p>PZ / PCS 1</p>	<p>Z1</p>  <p>PZ / PCS 2</p>	<p>Z3</p>  <p>PZ / PCS 2</p>
<p>R</p>  <p>PZ / PCS 1</p>	<p>U</p>  <p>PZ / PCS 1</p>	<p>X2</p>  <p>PZ / PCS 2</p>
<p>P</p>  <p>PZ / PCS 1</p>	<p>K5</p>  <p>PZ / PCS 1</p>	<p>K6</p>  <p>PZ / PCS 1</p>
<p>Q</p>  <p>PZ / PCS 1</p>	<p>K7</p>  <p>PZ / PCS 2</p>	<p>C2</p>  <p>PZ / PCS 1</p>

1

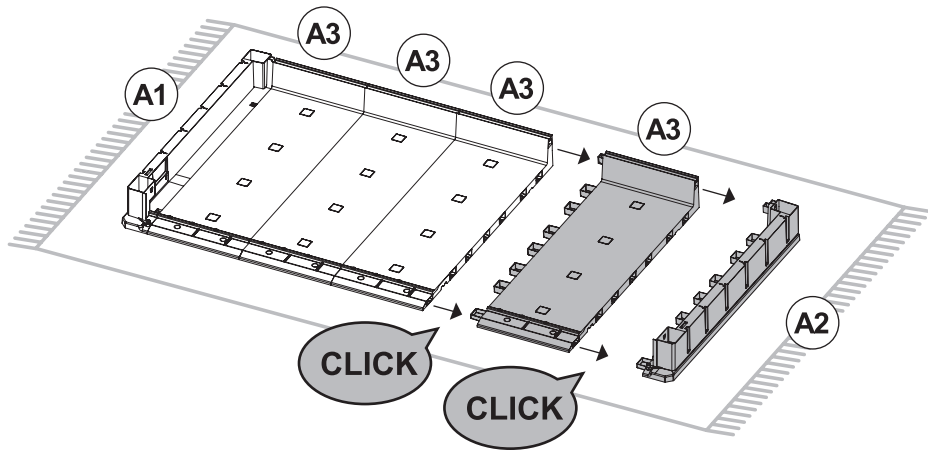
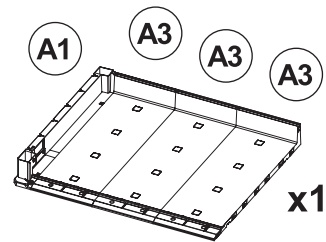
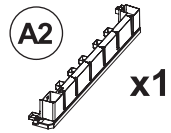
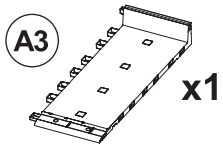

2

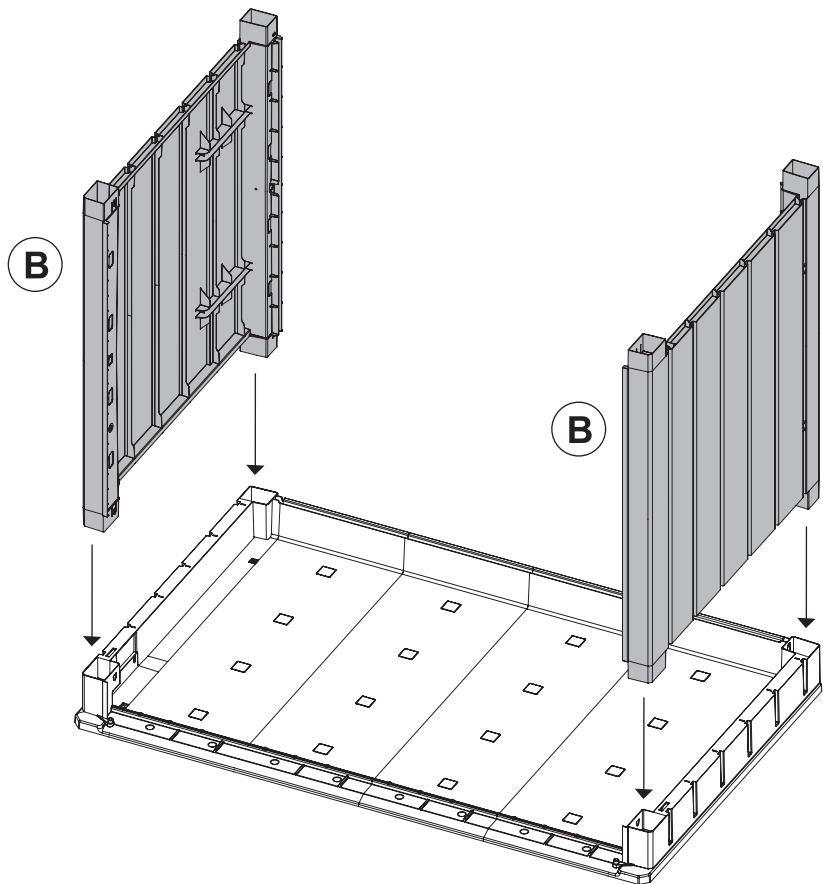
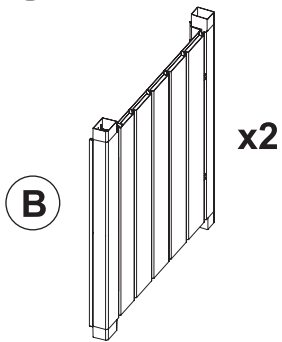

3

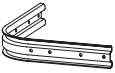
- Y  x8
- W  x2

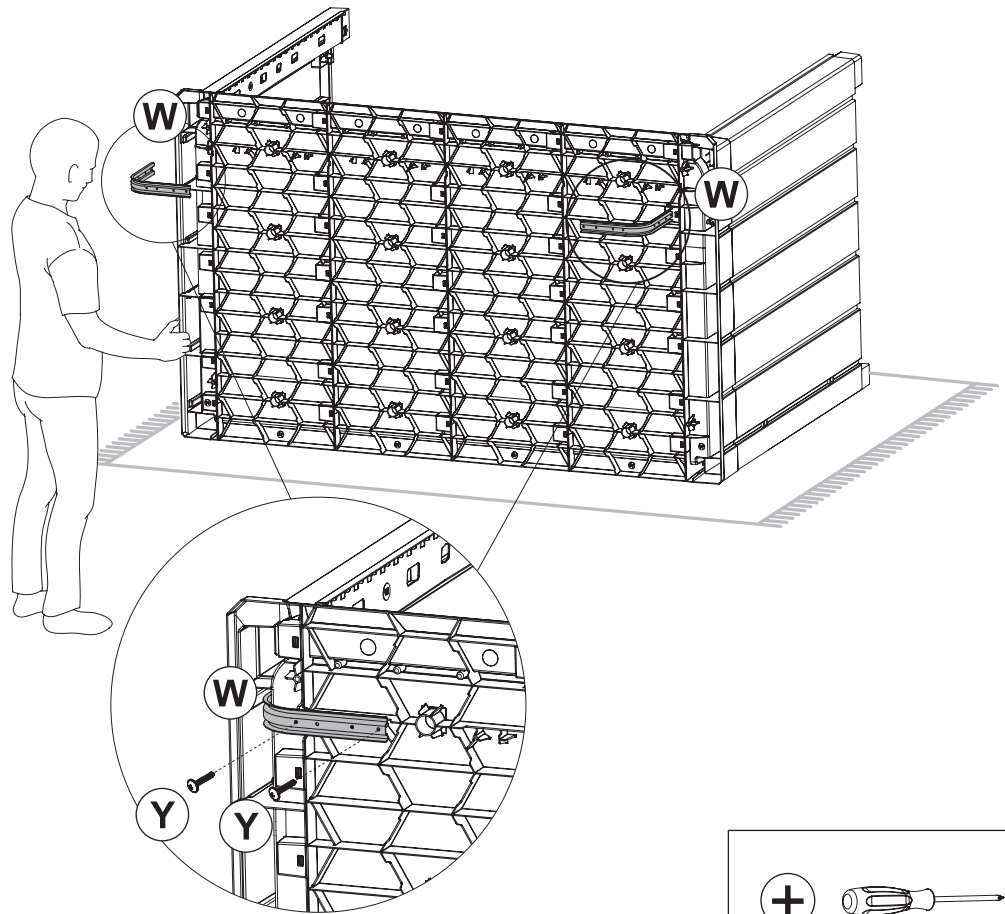

4

- Y  x4

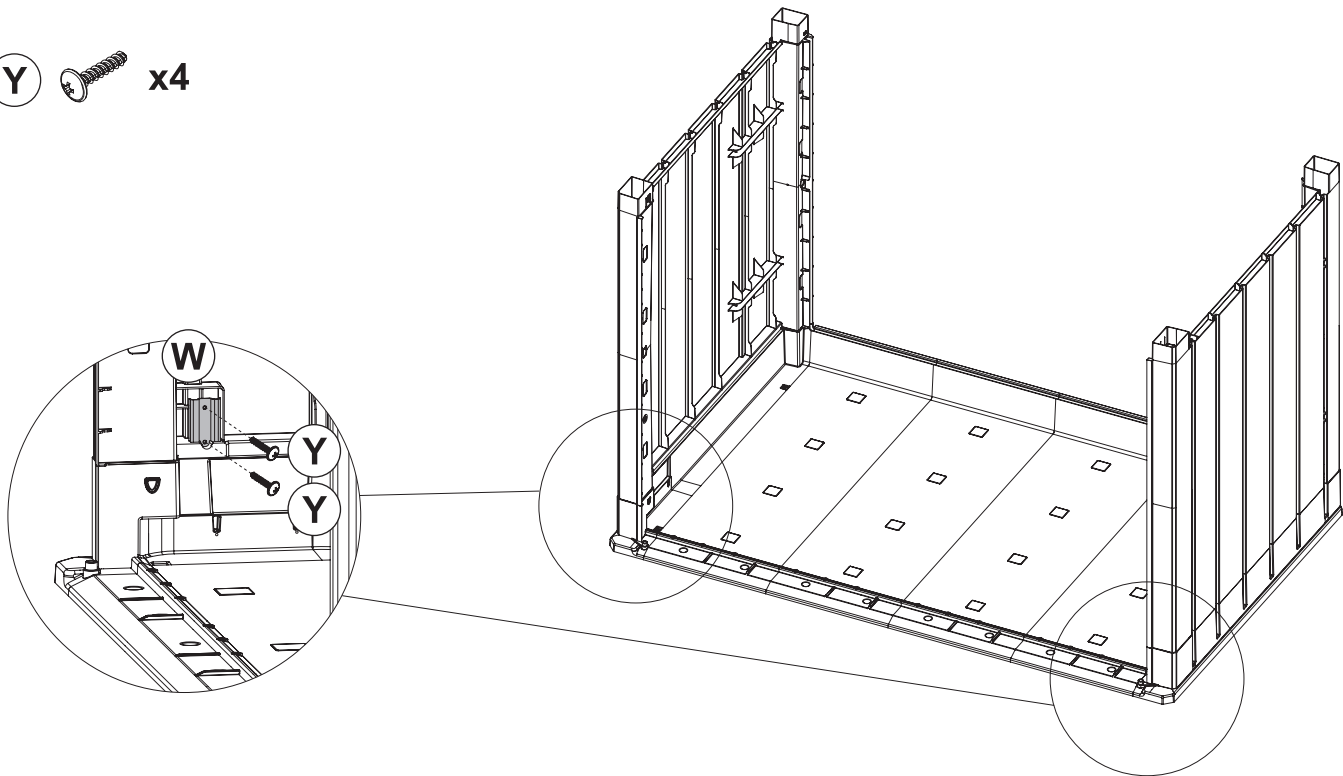

5

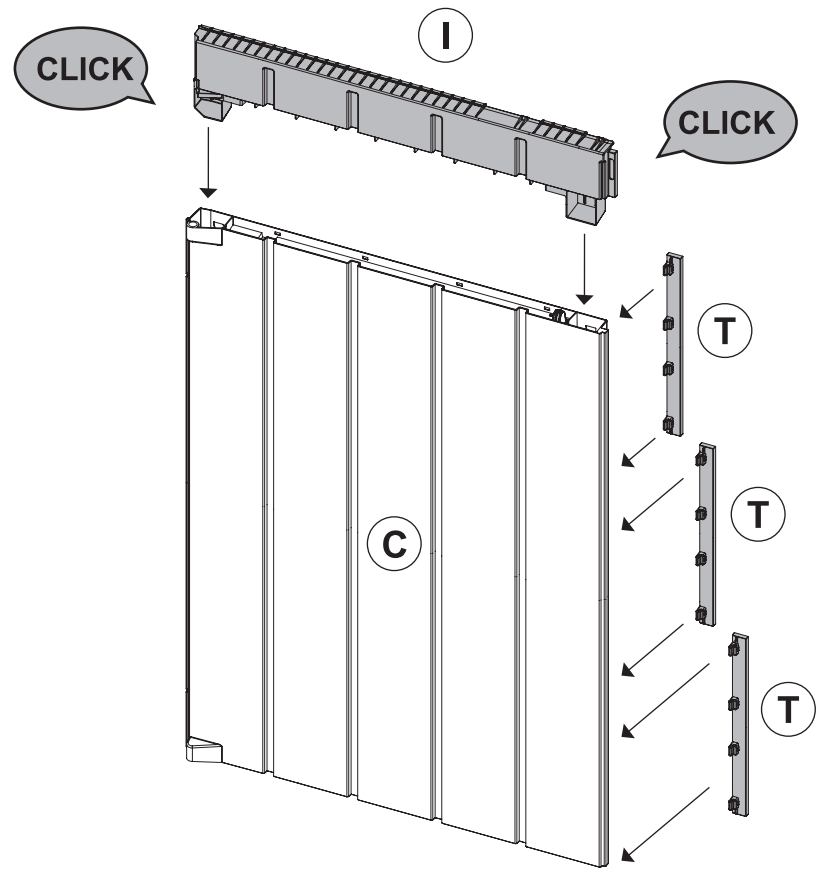
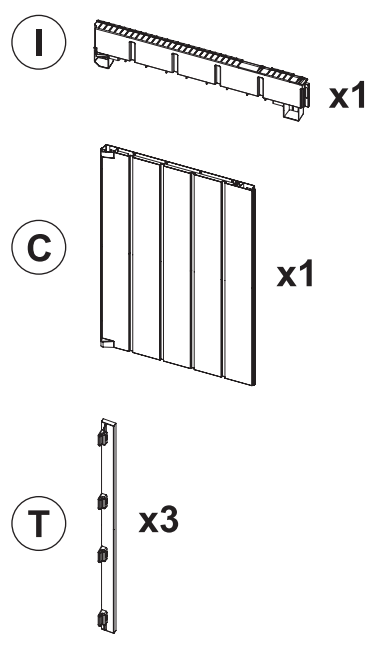

6

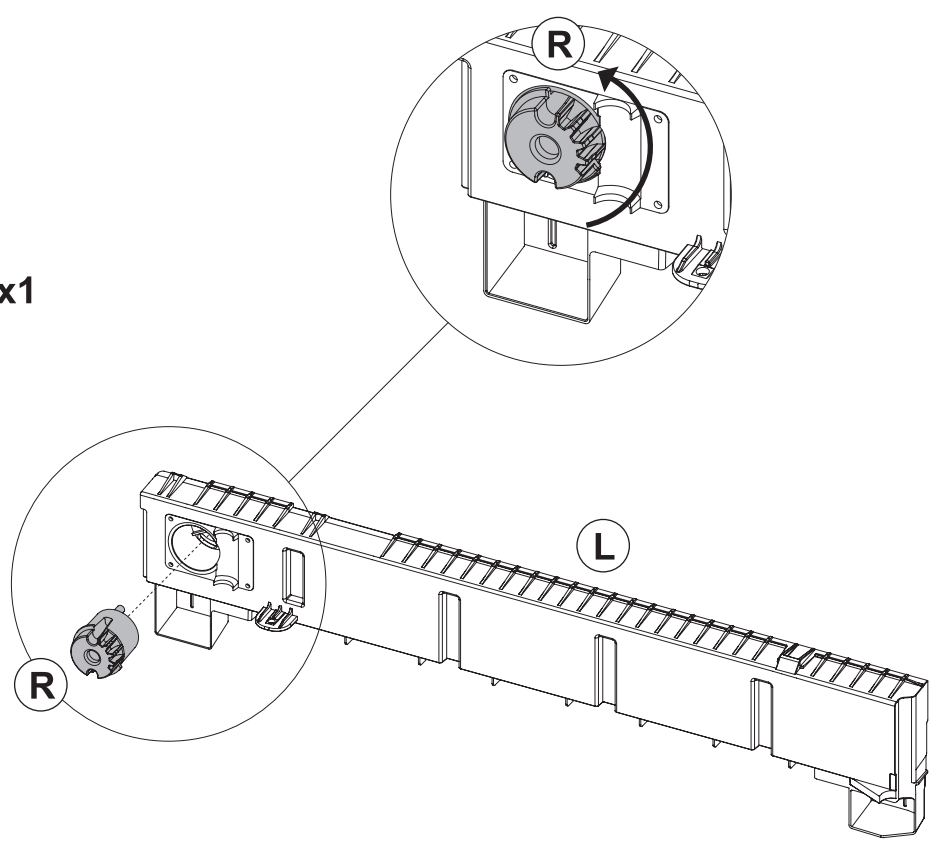
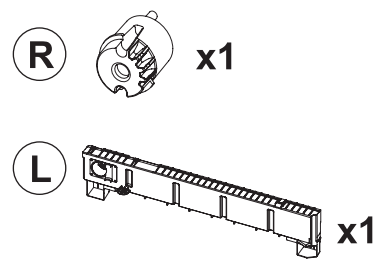

7

P x1

U x1

Y x4

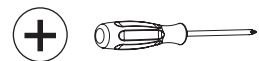
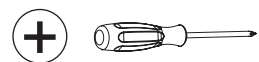
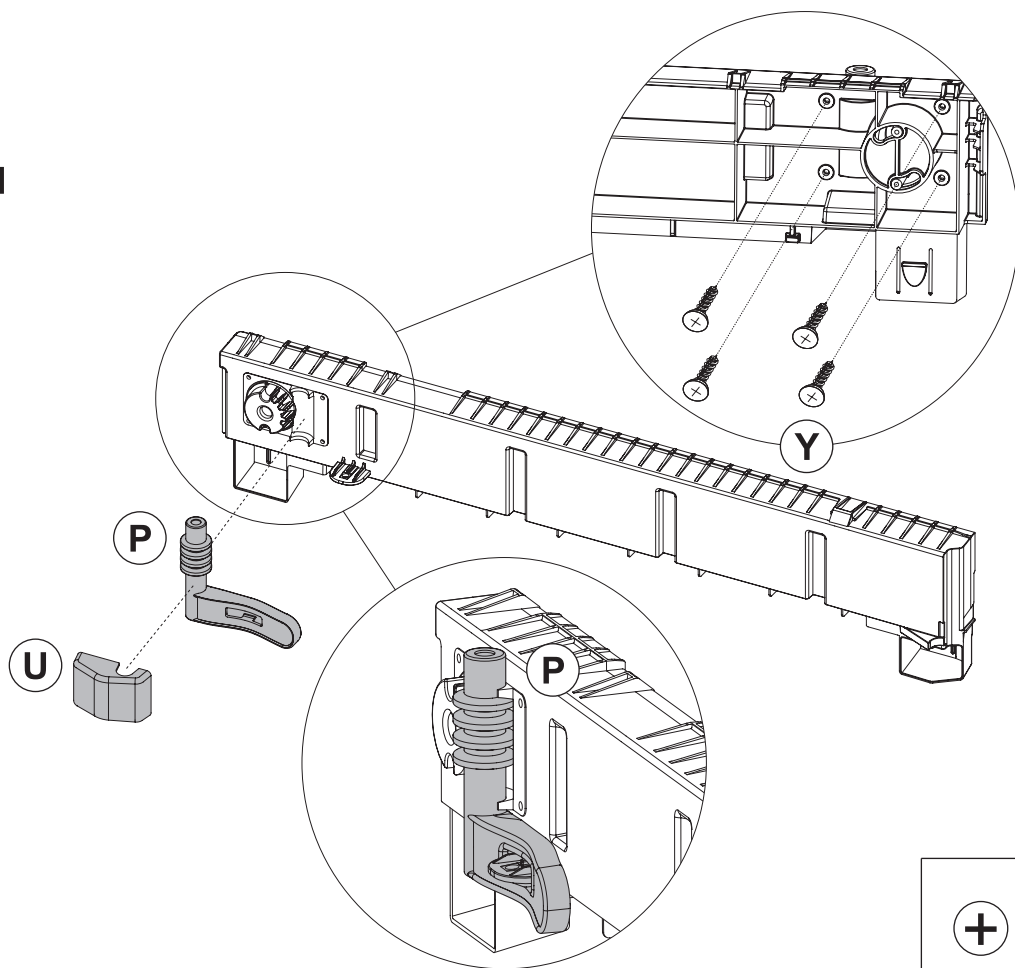

8

Q x1

Y x2

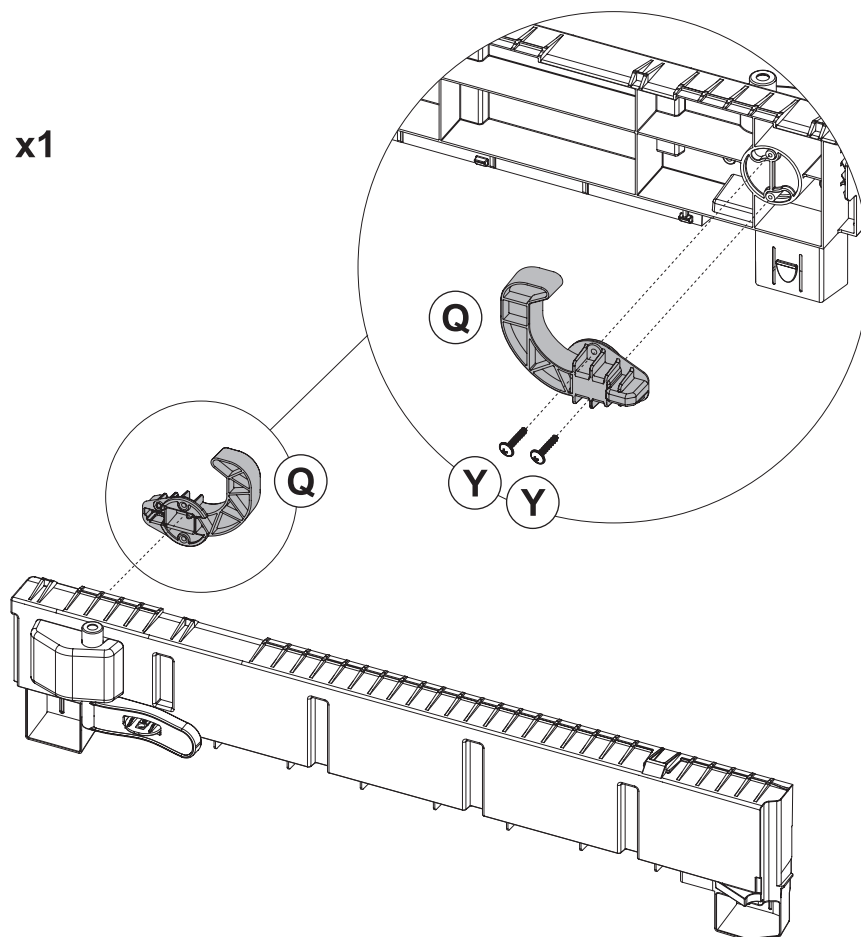

9

C

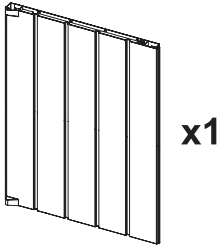

CLICK

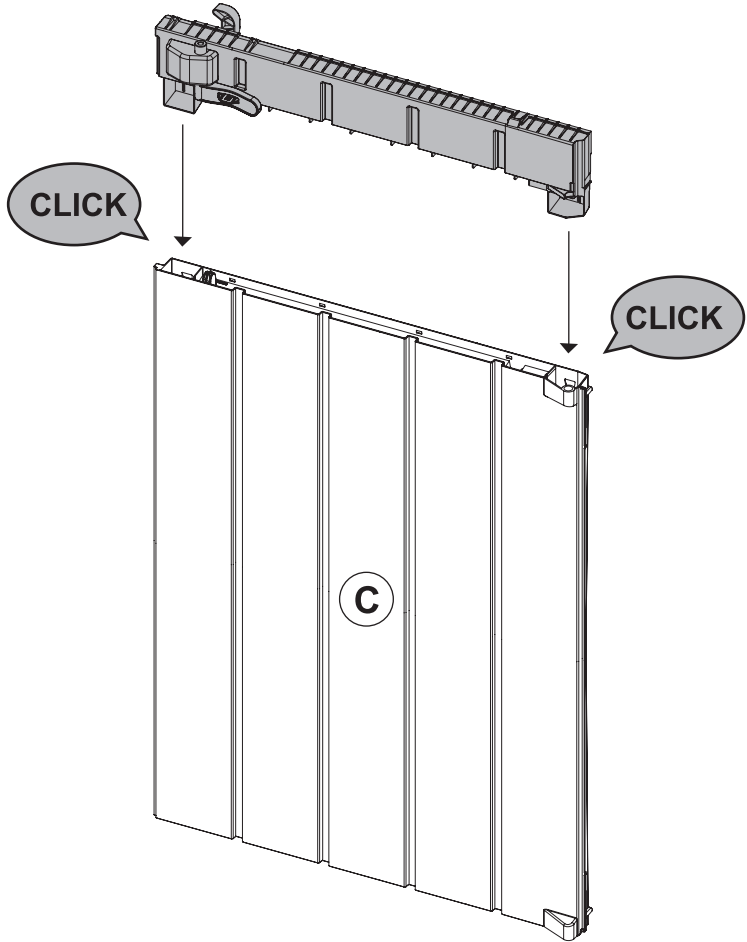

10

C2

x1

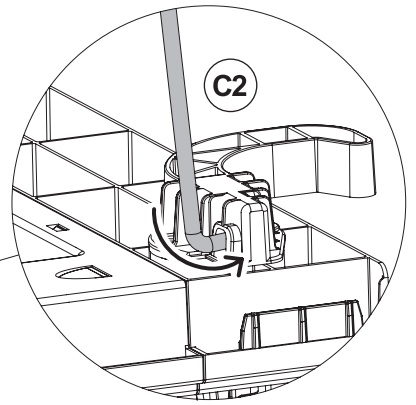
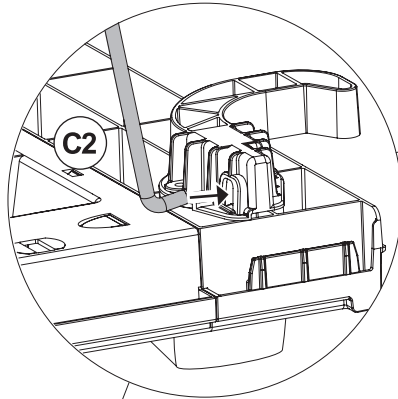
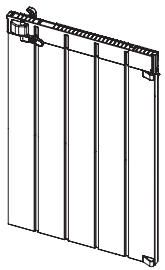

C2

10.1

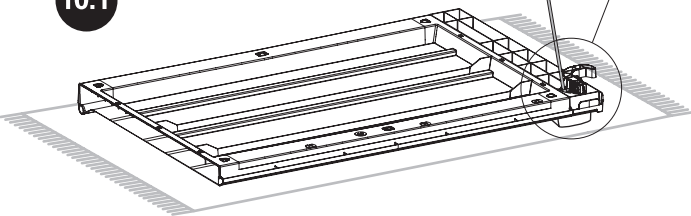

10.2

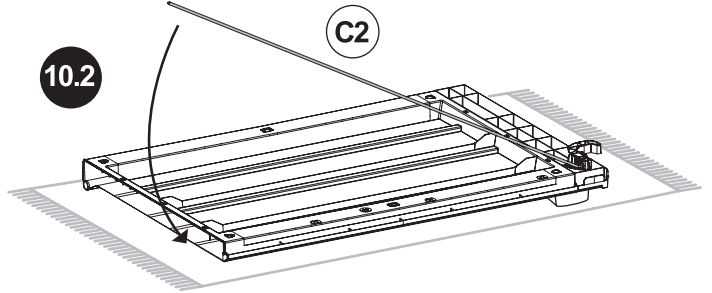

C2

11

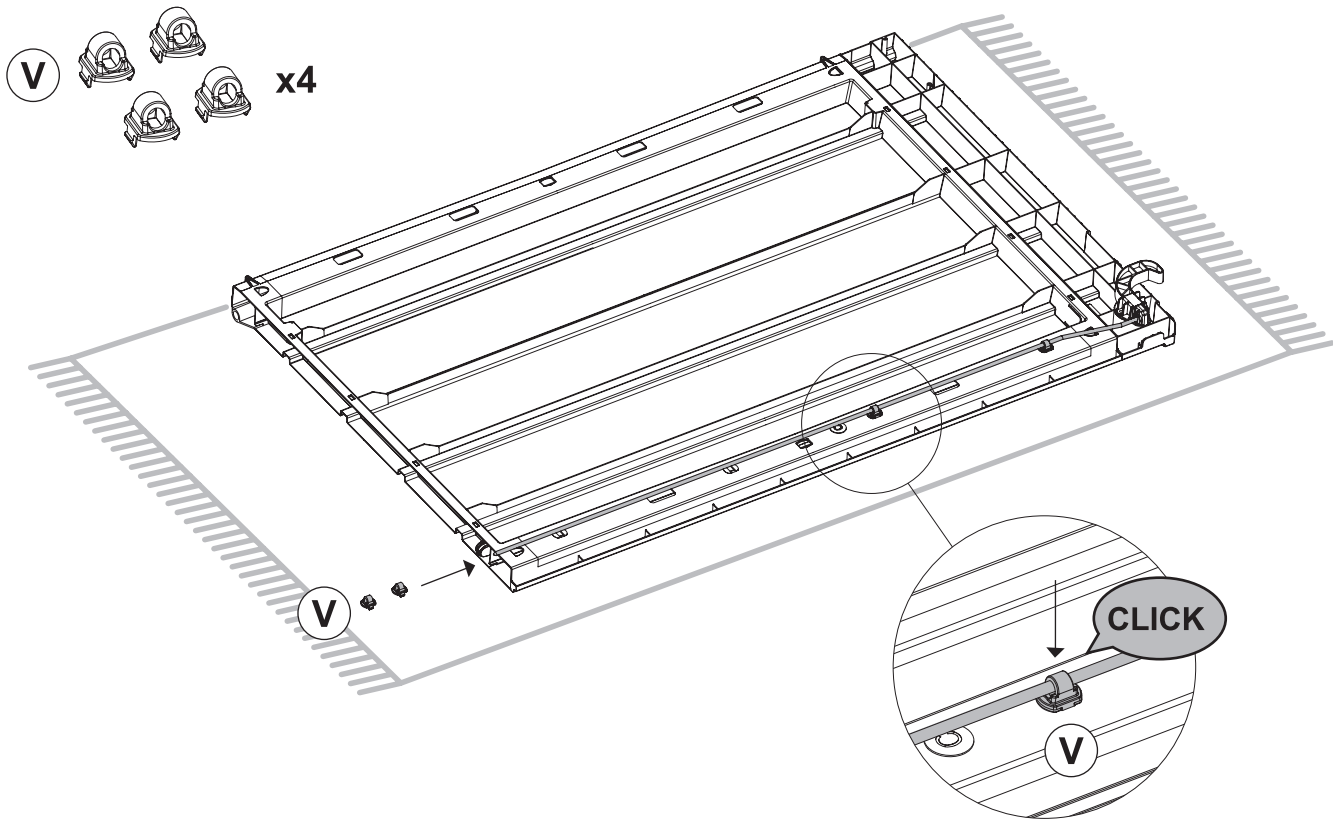

12

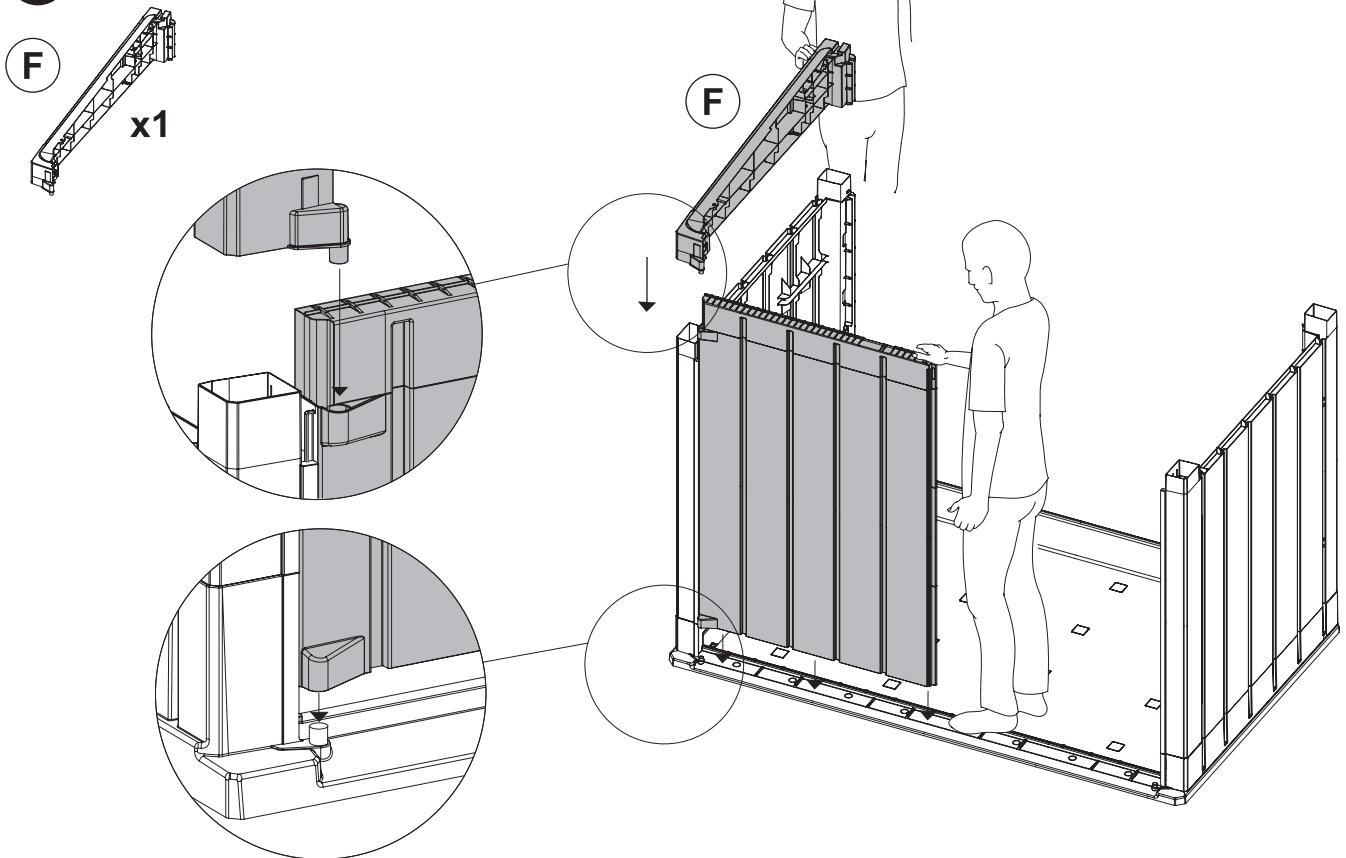

13

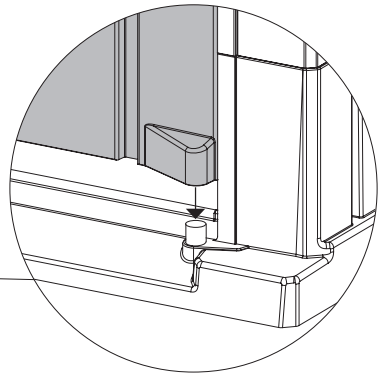
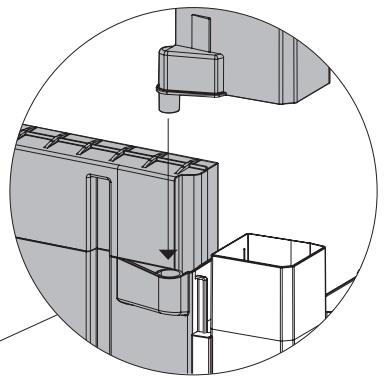
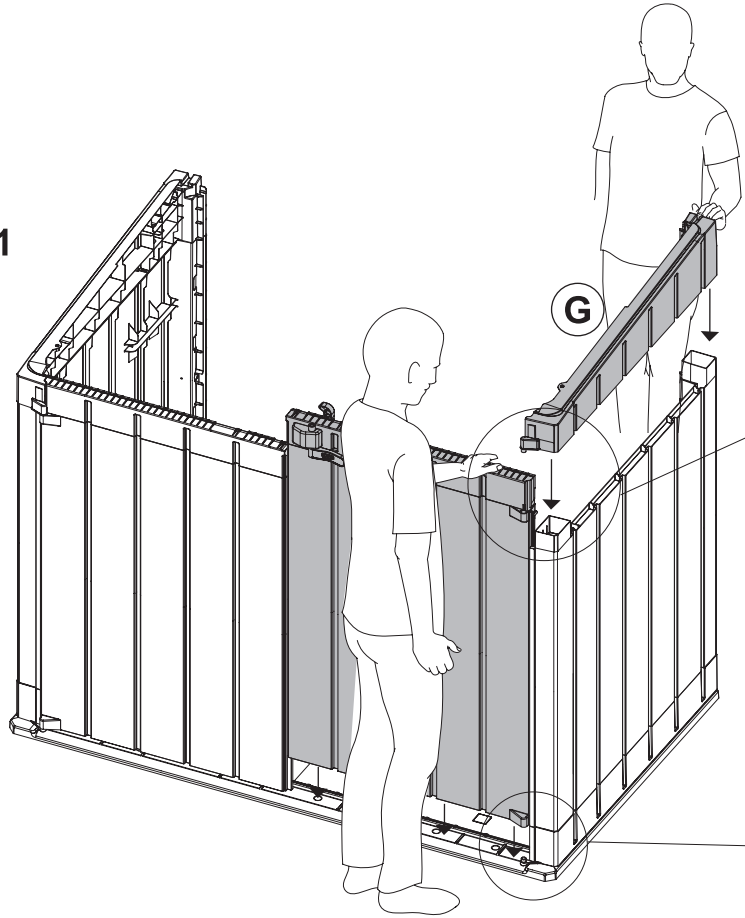
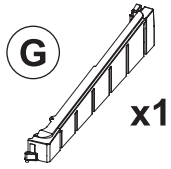

14

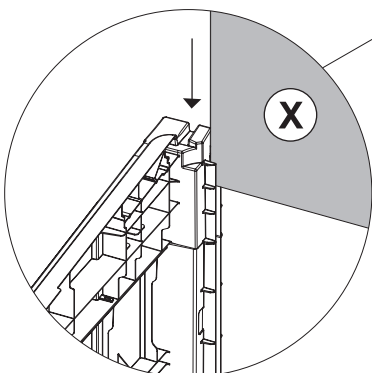
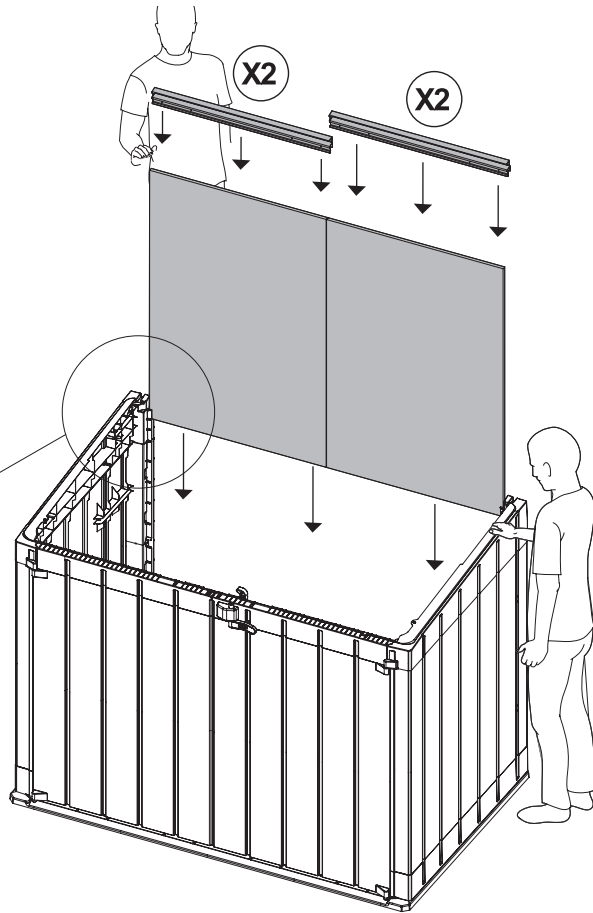
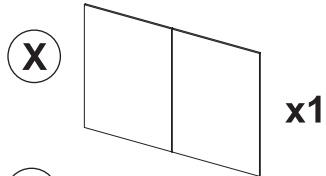

15

Y  x6

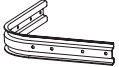
W  x2

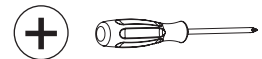
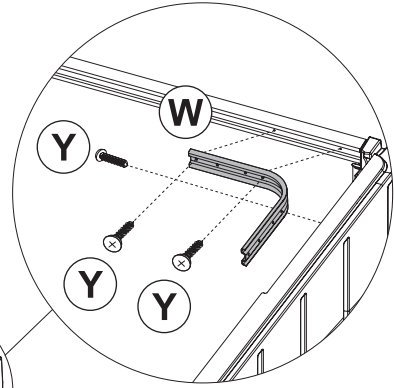
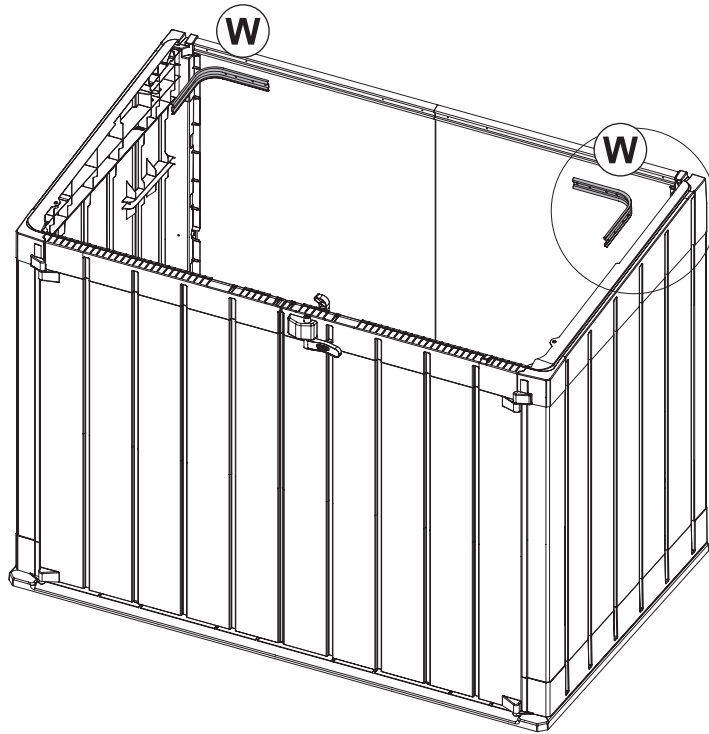

16

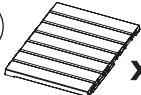
K1  x2

K2  x4

Z2  x4

Z1  x2

Z3  x2

K7  x2

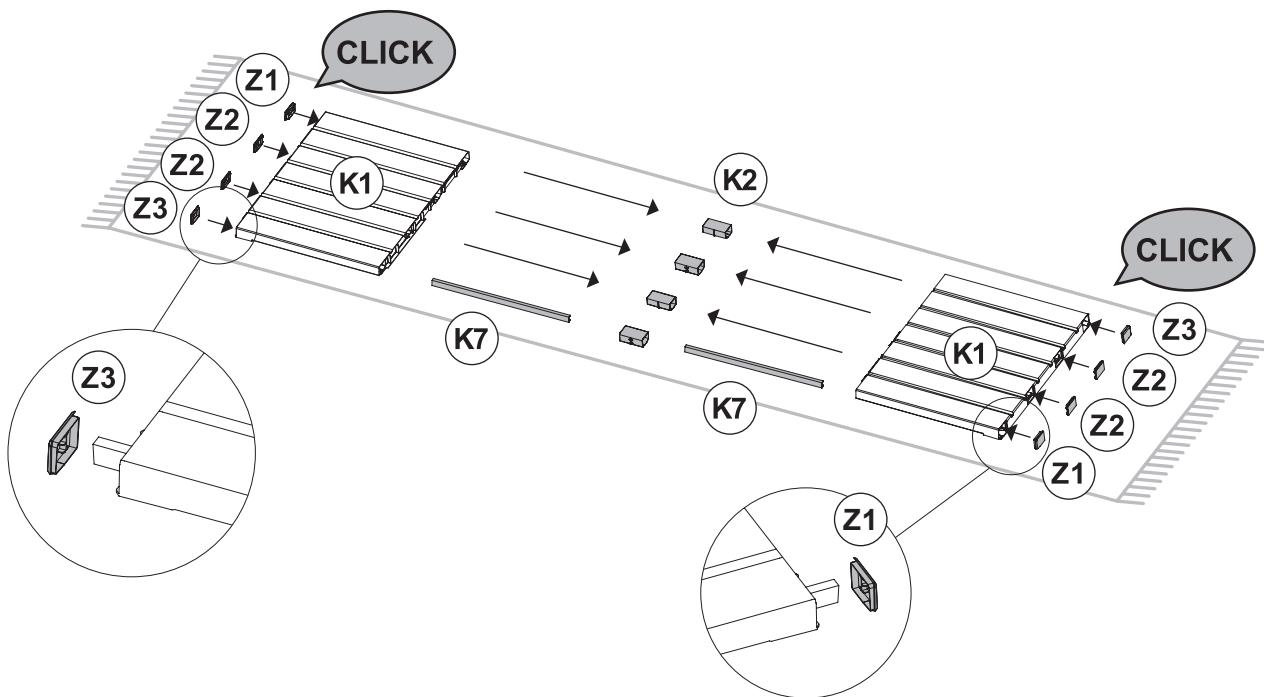

17

K4

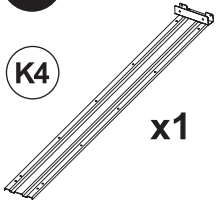

Y



S

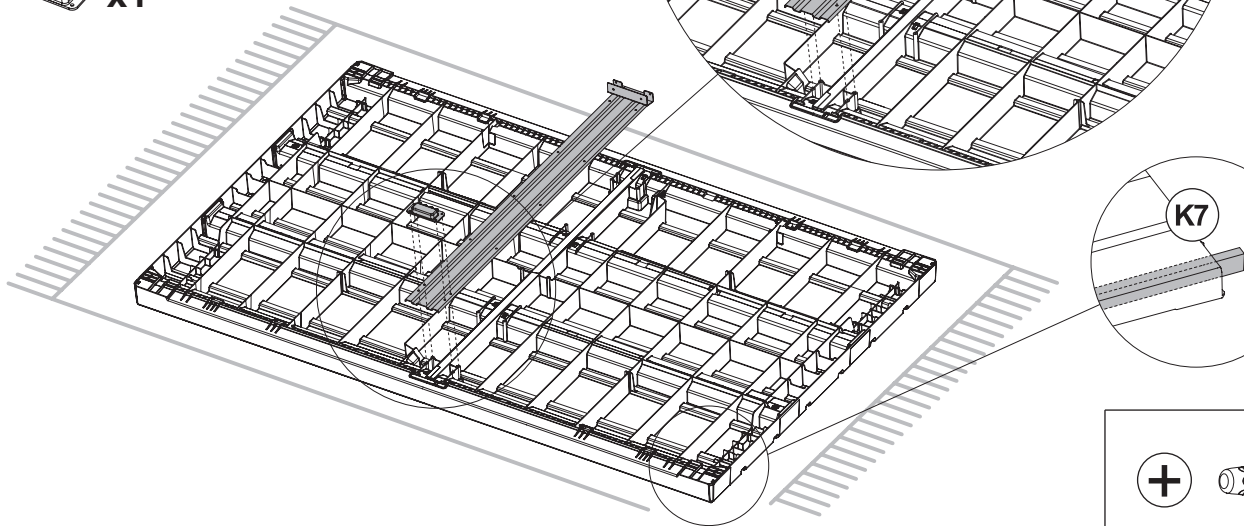

+

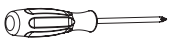

+

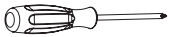

18

Y



K5

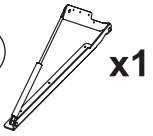

K6

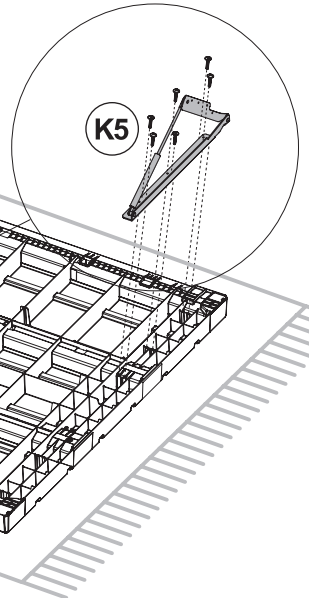
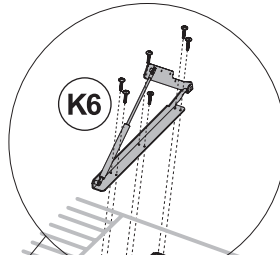
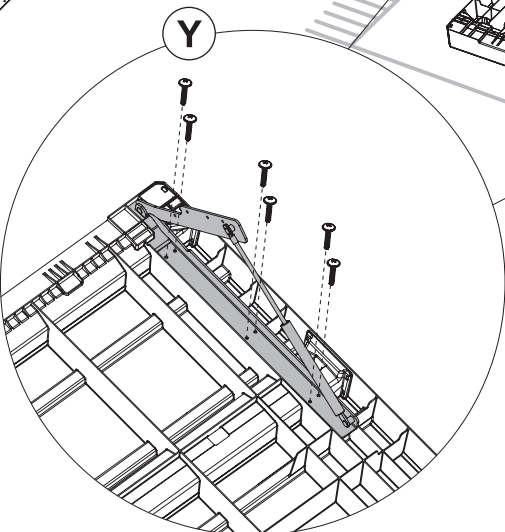
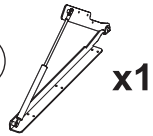

19

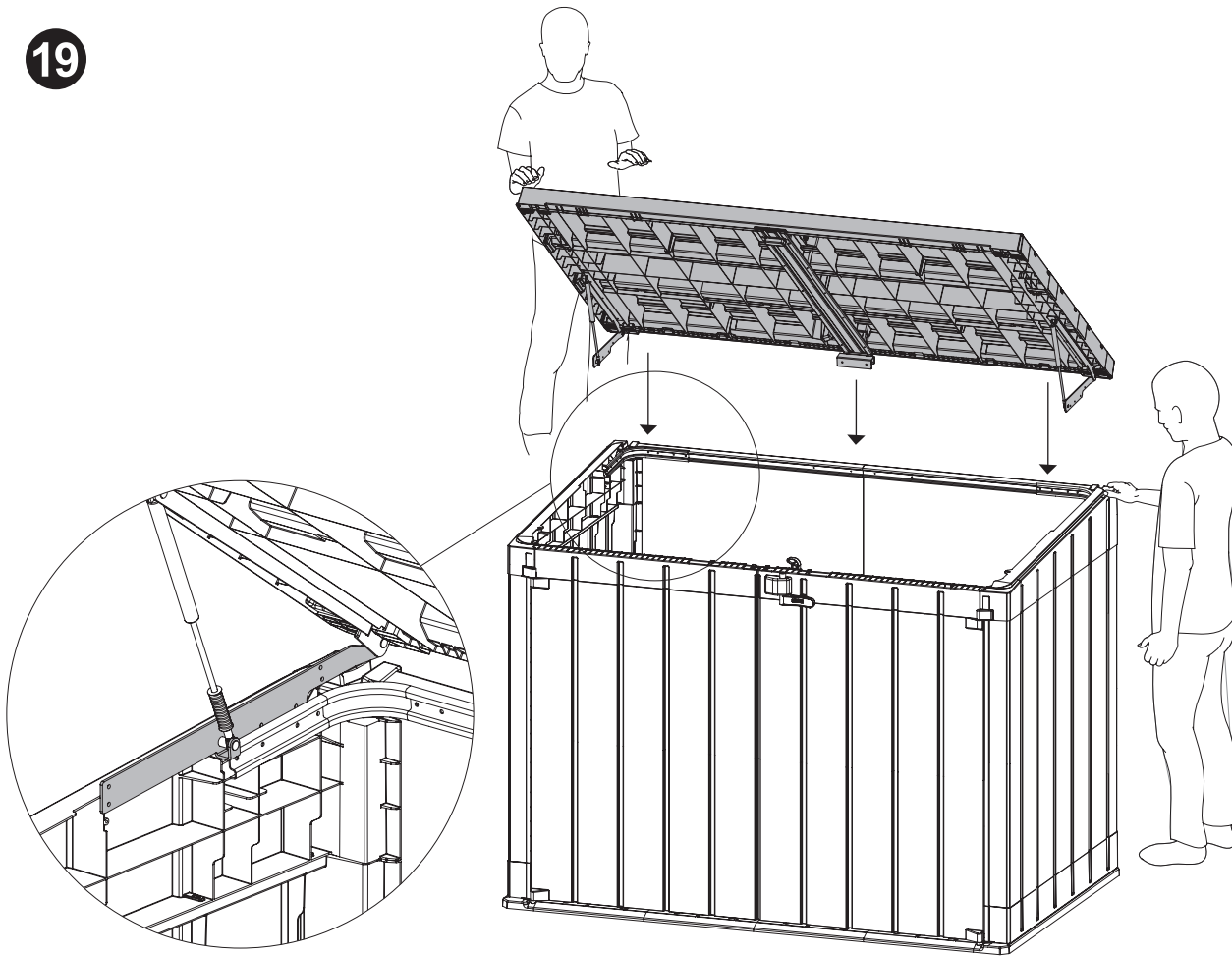

20

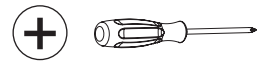

Y x14

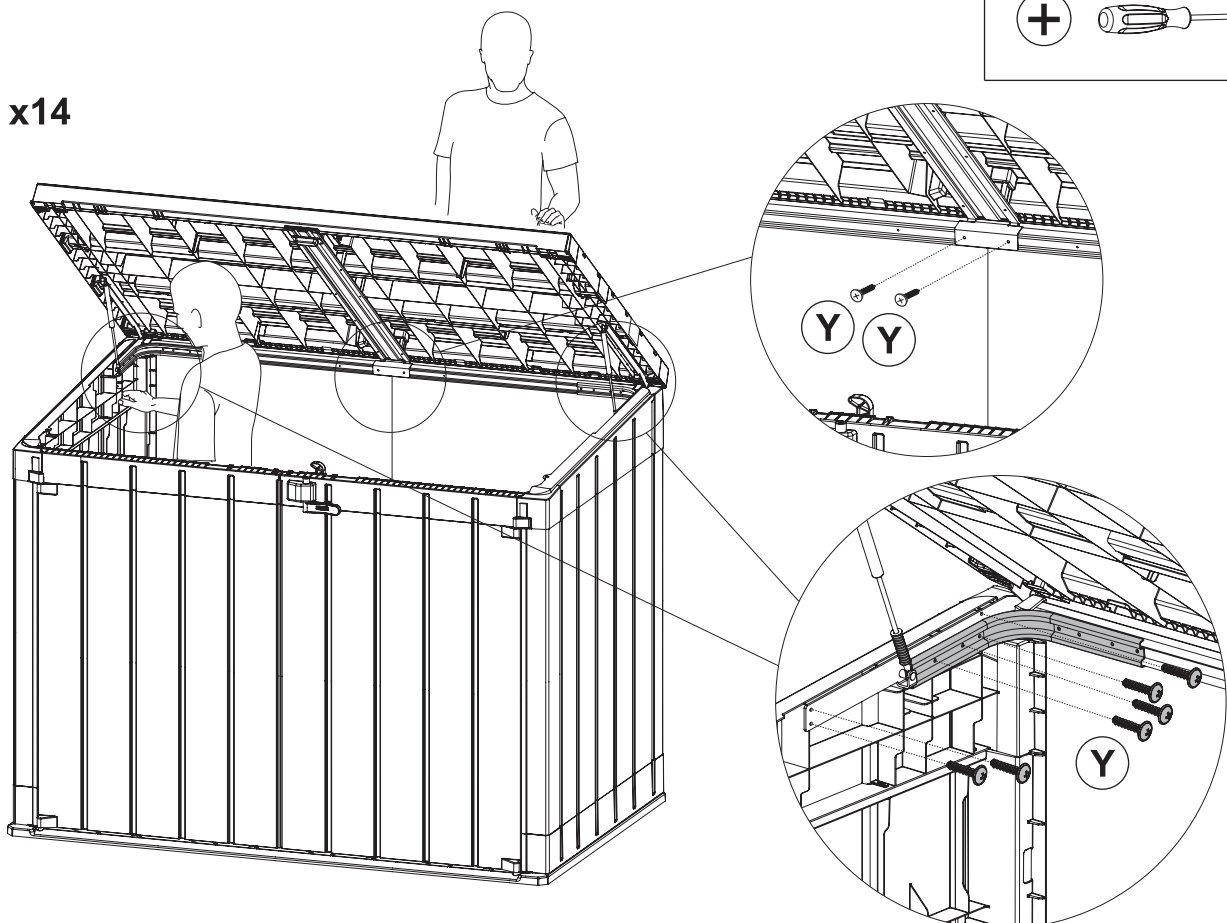

21

Y  x2

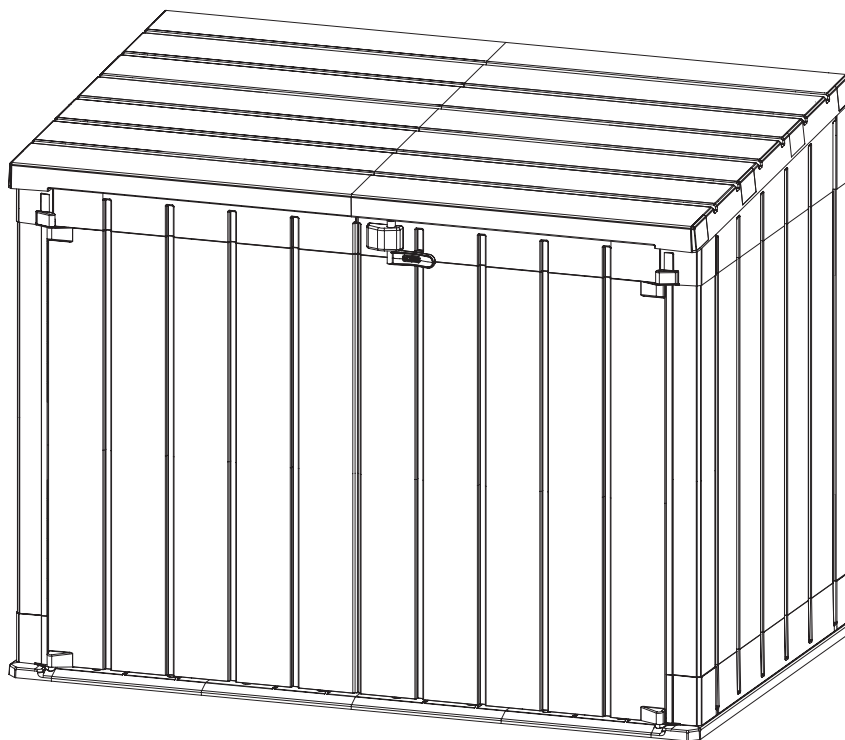
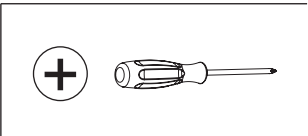
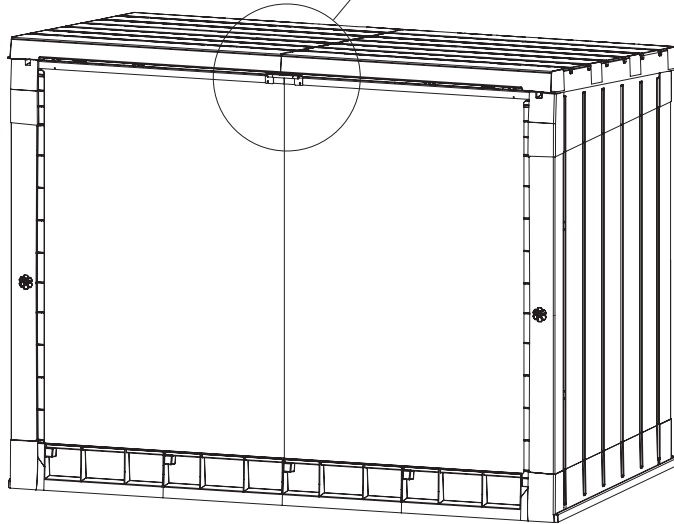
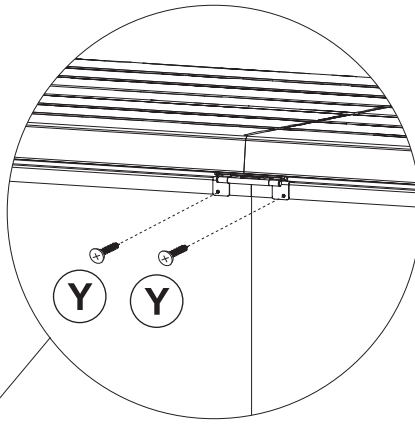

OPZIONE 1 / OPTION 1

IT: Catenella per apertura coperchio pattumiere (pattumiere non incluse)

EN: Chain for bin lid opening (bins not included)

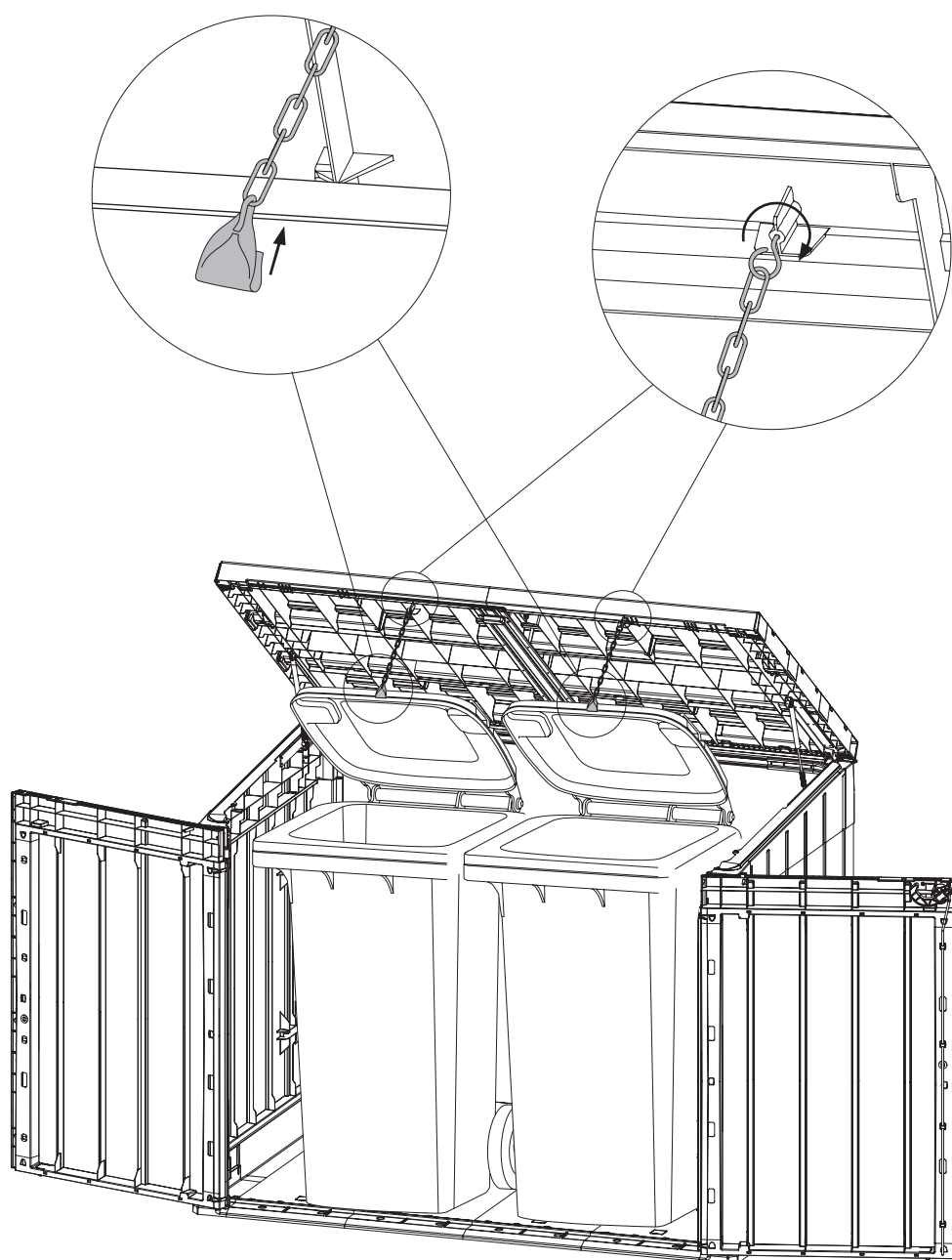
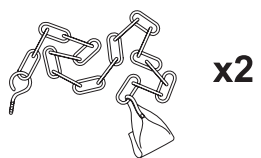

OPZIONE 2 / OPTION 2

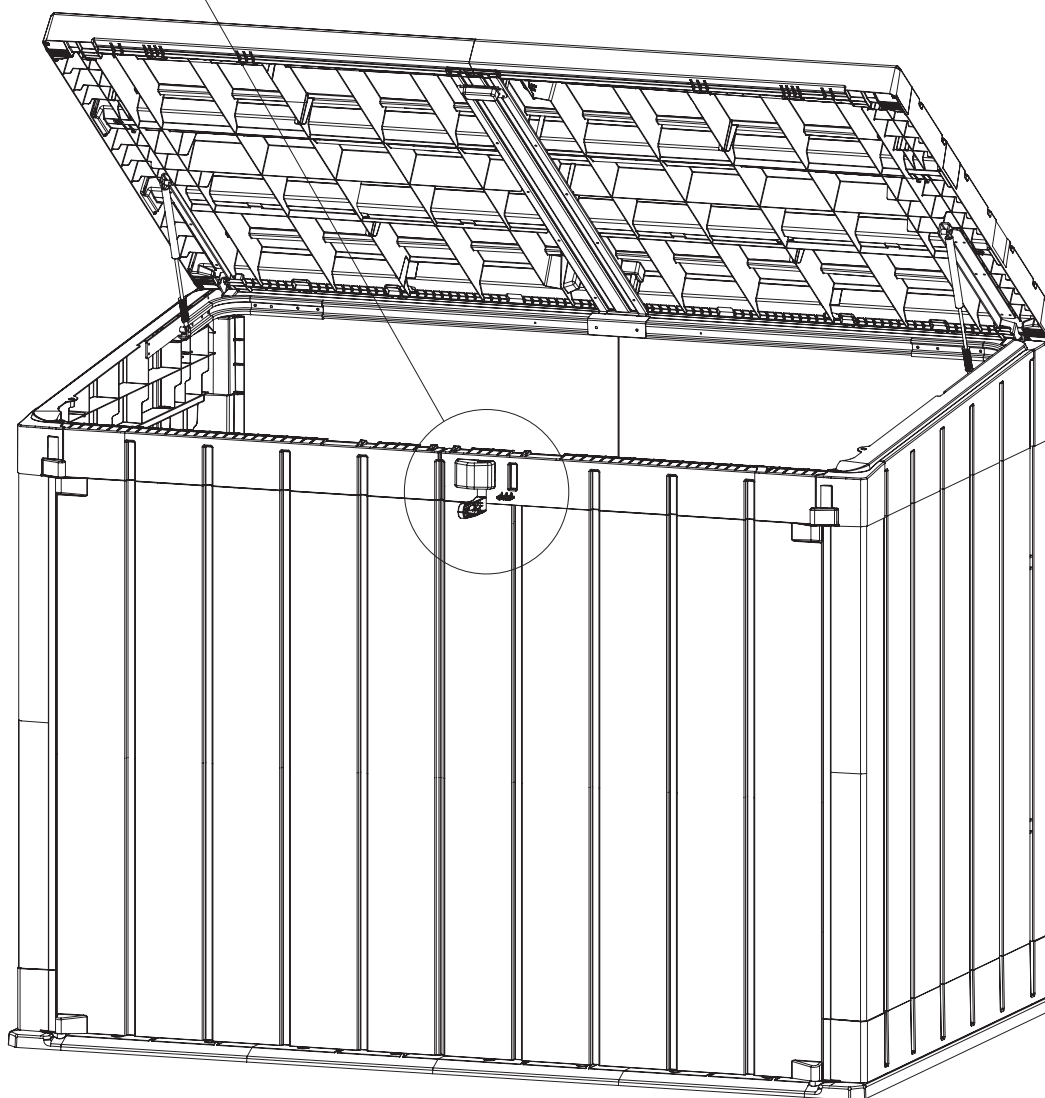
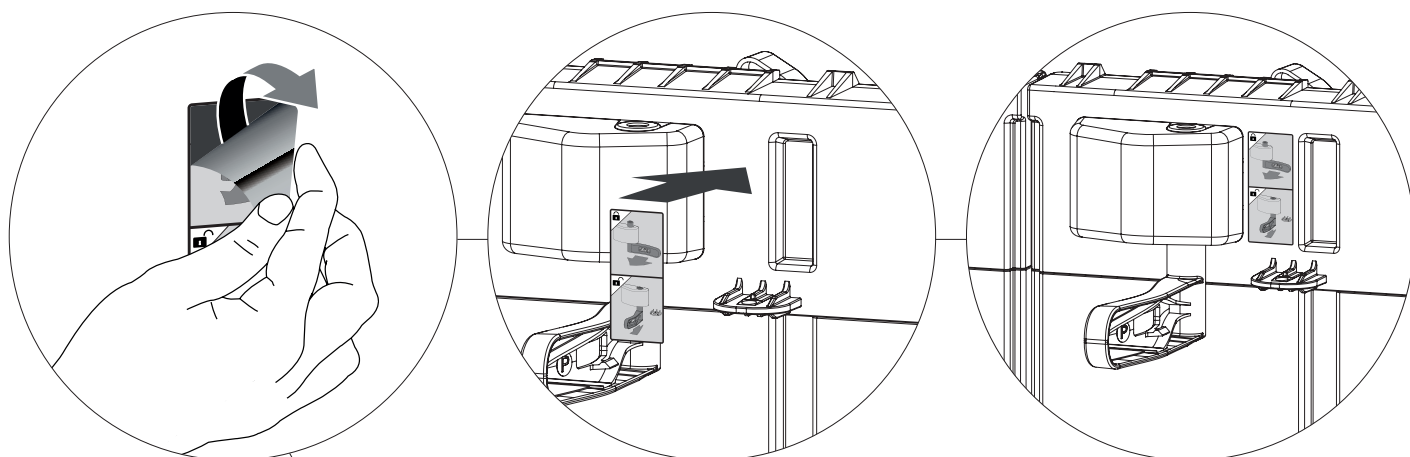

OPZIONE 3 / OPTION 3

IT: Fissaggio a muro **EN: Wall mounting**

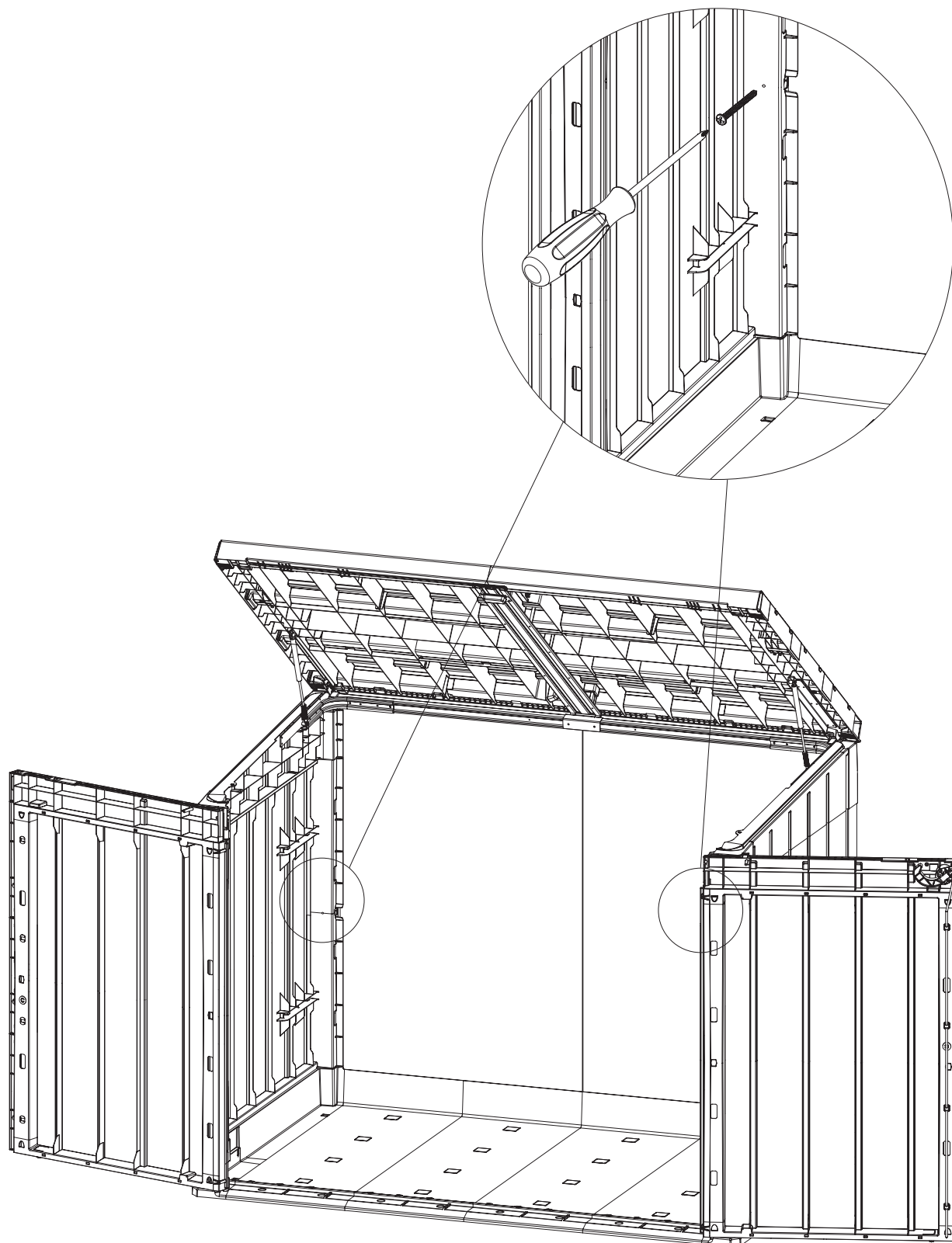

2x M4



2x Ø 6 mm

OPZIONE 4 / OPTION 4

IT: Fissaggio a terra **EN:** Ground fixing

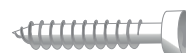
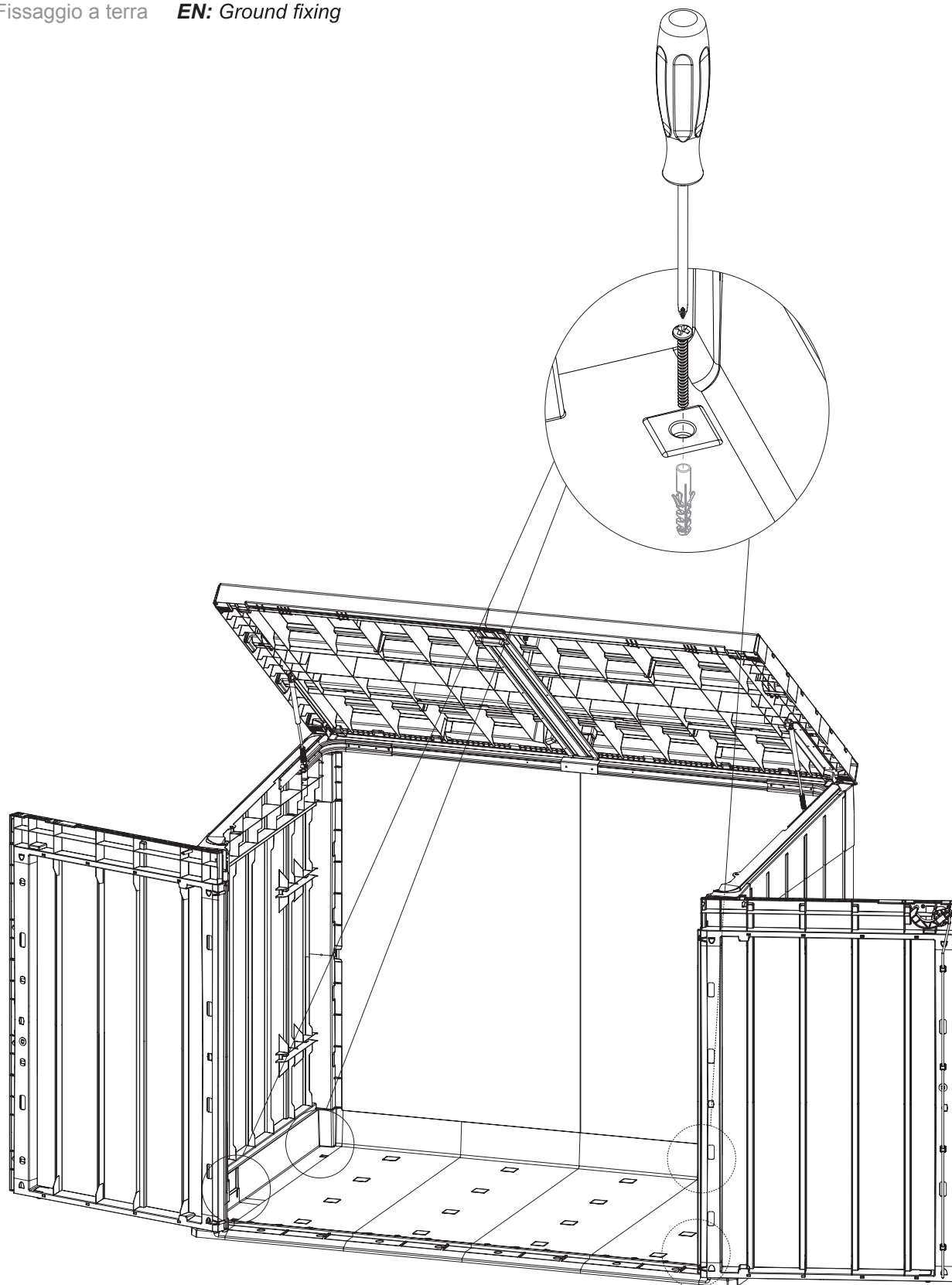

4x M4



4x Ø 6 mm

OPZIONE 5 / OPTION 5

IT: Opzionalmente è possibile acquistare una tavola di legno da utilizzare come mensola

EN: It is possible to purchase, as an option, a wooden plank and use it as a shelf

IT: Dimensioni consigliate **EN:** Suggested dimensions

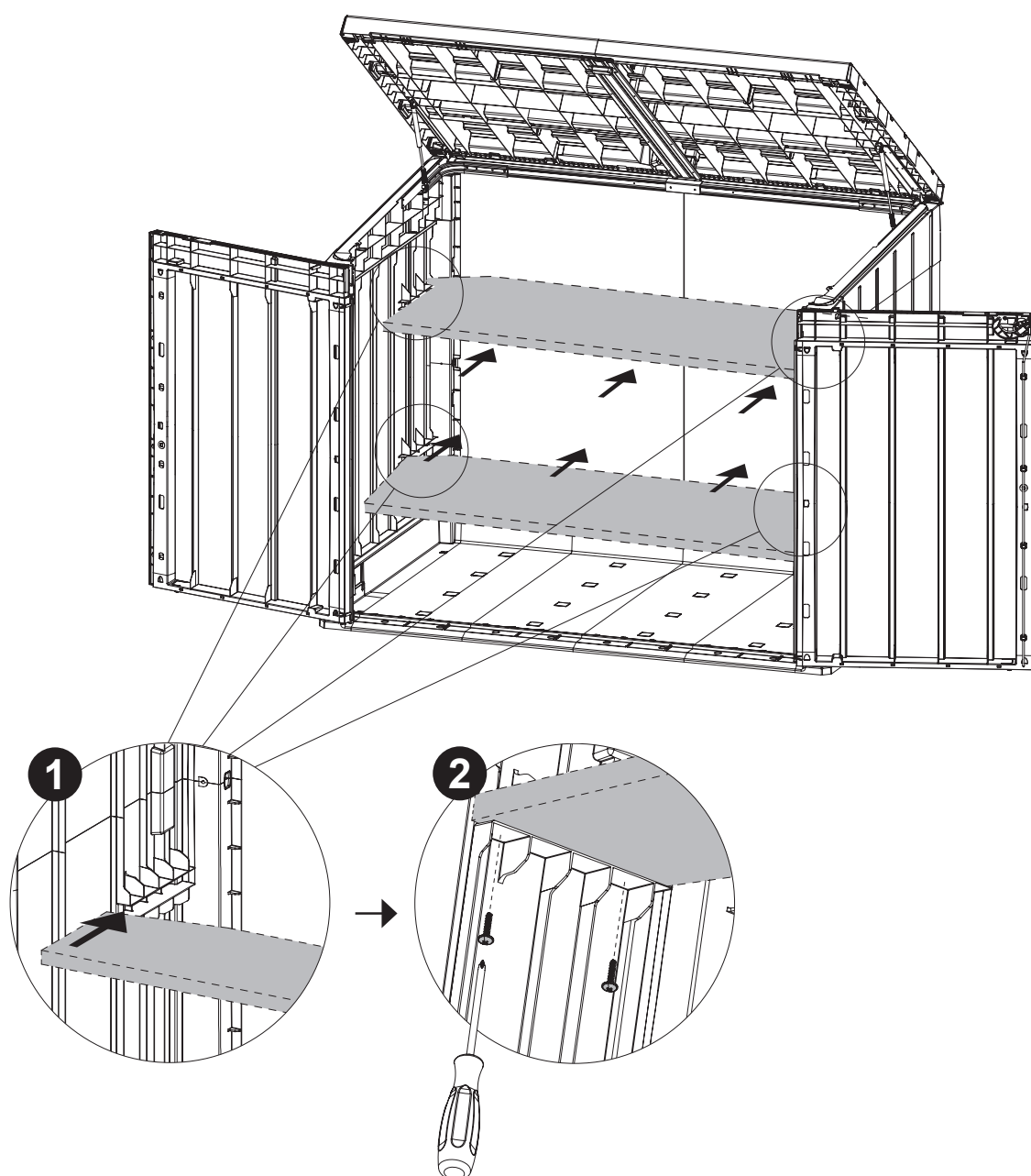
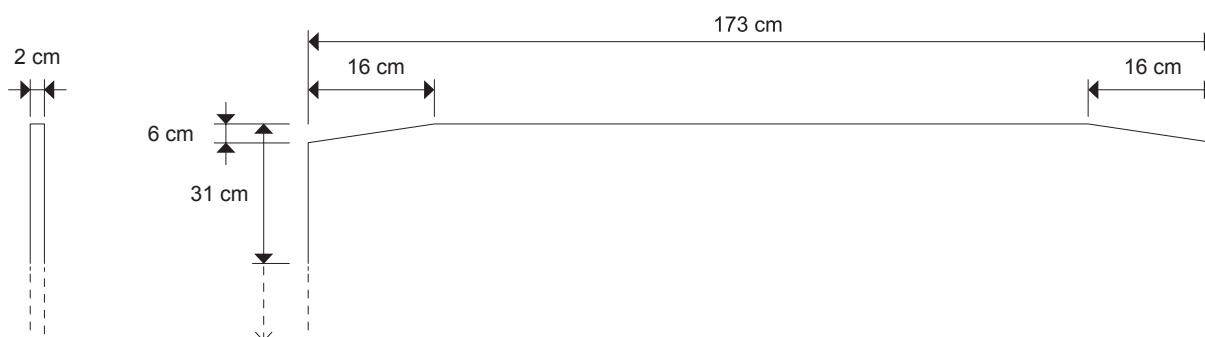



Plastmeccanica S.p.A.

Viale del Lavoro, 3

60030 Castelfellino (An) - ITALY

Tel. +39 0731 70766 - Fax +39 0731 703796

info@plastmeccanica.it



www.toomax.it