

# BUSH

## Instruction Manual

BECF99L  
BECF142L  
BECF198L  
MECF99W



You'll soon be enjoying your new chest freezer.

It all begins here, with your instructions. Don't worry, there's nothing too technical coming up. Just simple, step-by-step guidance to get you up and running quickly. Sound good? Then let's get started.

## Help and Guidance

We're here to help you get the most from your chest freezer. Should you require any guidance, a simple solution can often be found online at:

**[www.bush-support.com](http://www.bush-support.com)**

If you still require further assistance, call one of our experts on **0345 257 7271**.

Issue-1, 29/7/2021

If you require any technical guidance or find that your product is not operating as intended, a simple solution can often be found in the **Troubleshooting** section of these instructions,

# Contents

## 1 Safety information

Safety information 6

## 2 Getting to know your chest freezer

Ready? Let's begin 12

Accessories 13

## 3 Installing your chest freezer

Transportation 16

Installation 16

Electrical connections 17

## 4 Using your chest freezer

Before first use 20

Using your appliance 20

Useful information 21

Energy saving tips 21

## 5 Care and Maintenance

General 24

Defrosting 24

Power failure 24

Moving your appliance 25

Technical specification 25

## 6 Product support

Troubleshooting 30

Help and assistance 31

Guarantee 32



# Safety information

1

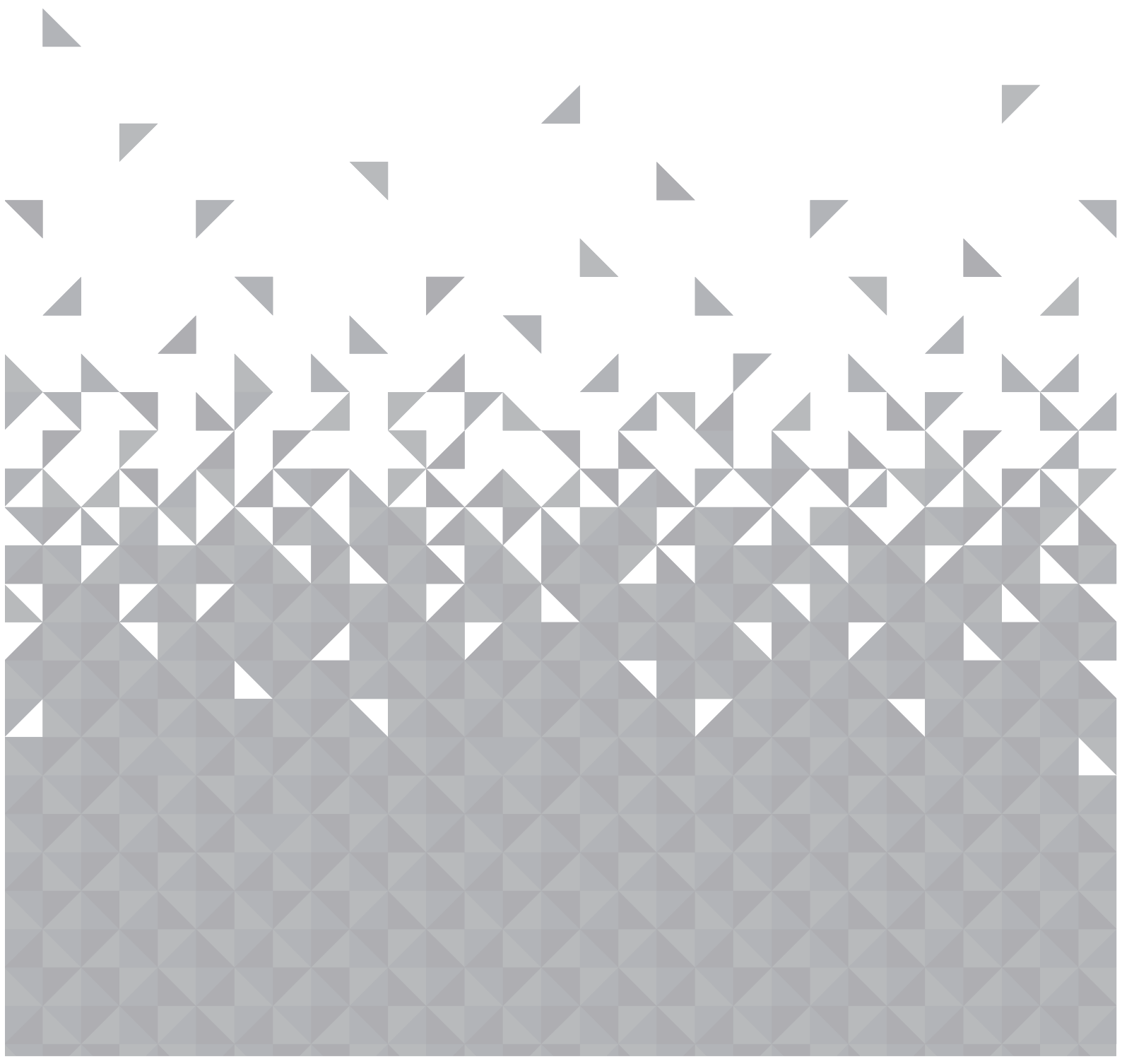



## Safety information

**Important-**Please read these instructions fully before installing or operating

### Before use

The installation of this appliance is best carried out by 2 people.

- Dispose of all packaging carefully and responsibly.
- The appliance is designed for **indoor use only** and must be protected from rain, moisture and extreme temperature variations.
- This appliance is designed for house hold use. **Do not** use the appliance for industrial and commercial use, or any other purpose.
- The appliance **MUST** be positioned on a firm level base.
- **Do not** splash water on the appliance. It may cause electrical parts to fail and result in an electric shock.
- Leave the appliance in

its intended place of installation and in its correct orientation for at least 4 hours before switching on to allow the cooling system to settle before first use or after any transportation.

- Your appliance is an environmental friendly product and it contains non CFC/HFC gas substances in the cooling system (Called R600a) and in the insulation (Called cyclopentane) which are potentially flammable if exposed to fire. Therefore, take care not to damage, the cooling circuit/pipes of the appliance in transportation and in use. In case of damage do not expose the appliance to fire,



## Safety information

**Important-**Please read these instructions fully before installing or operating

potential ignition source and immediately ventilate the room where the appliance is situated.

- **Do not** sit, stand or place any other heavy objects on top of the appliance. This could result in injury or damage to the appliance.
- **Do not** allow children to play with the appliance to avoid the risk of entrapment and suffocation.
- Keep ventilation opening, in the appliance enclosure or in the built-in structure, clear of obstruction.

During use

- This appliance is not intended for use by persons (including

children) with reduced physical, sensory or mental capabilities, or lack of experience and knowledge, unless they have been given supervision or instruction concerning use of the appliance by a person responsible for their safety. Children should be supervised to ensure that they do not play with the appliance.

- This appliance is not intended for use by young children or infirm persons unless they have been adequately supervised by a responsible person to ensure that they can use the appliance safely. Young children should be supervised to ensure that they do not play with the appliance.

- **Do not** use mechanical,



## Safety information

**Important**-Please read these instructions fully before installing or operating

electrical or chemical way to speed up the defrost process not recommended by the manufacturer.

- **Do not** use or place other electrical products inside the appliance not recommended by the manufacturer.
- **Do not** store liquids in glass containers in the freezer compartment as these may shatter.
- **Do not** store flammable materials such as alcohol, gasoline, LP gas or glue etc in the appliance.
- In case there is an inflammable gas leaking, open the window for air circulation and do not pull out the plug or turn the temperature knob. **Do not** touch the appliance until the valve of gas is turned off. Otherwise, sparks may happen.
- This appliance can be used by children aged from 8 years and above and persons with reduced physical, sensory or mental capabilities or lack of experience and knowledge if they have been given supervision or instruction concerning use of the appliance in a safe way and understand the hazards involved. Children shall not play with the appliance. Cleaning and user maintenance shall not be made by children without supervision.
- Cord entanglement hazard. The cable of the appliance can give rise to risks of entanglement, strangulation or tripping if not correctly placed. You must make sure that the electric cable is positioned safely.

If you require any technical guidance or find that your product is not operating as intended, a simple solution can often be found in the Troubleshooting section of these instructions.



## **Safety information**

**Important**-Please read these instructions fully  
**Before use** before installing or operating



**WARNING:** risk of fire

- **When** positioning the appliance, ensure the supply cord is not trapped or damaged.
- **Do not** locate multiple portable socket-outlets or portable power supplies at the rear of the appliance.
- **Children** aged from 3 to 8 years are allowed to load and unload refrigerating appliances.
- **To** avoid contamination of food, pay attention to the following:
  - opening** the door for long periods can cause a significant increase of the temperature in the compartments of the appliance;
  - clean** regularly surfaces

that can come in contact with food and accessible drainage systems;

- clean** water tanks if they have not been used for 48 hours; flush the water system connected to a water supply if water has not been drawn for 5 days;
- store** raw meat and fish in suitable containers in the refrigerator so that it is not in contact with or drip onto other food;
- two-star frozen**-food compartments are suitable for storing pre-frozen food, storing or making ice-cream and making ice cubes;
- one-, two- and three-star** compartments are not suitable for the freezing of fresh food;



## Safety information

**Important-**Please read these instructions fully before installing or operating

- if the refrigerating appliance is left empty for long periods, switch off, defrost, clean, dry and leave the door open to prevent mould developing within the appliance.
- **Do not** attempt to repair the appliance yourself. Contact the Customer Helpline: **0345 257 7271**.
- For a freestanding appliance: this refrigerating appliance is not intended to be used as a built-in appliance.
- Cord entanglement hazard. The cable of the appliance can give rise to risks of entanglement, strangulation or tripping if not correctly placed. You must make sure that the electric cable is positioned safely.

### Using your chest freezer

### Getting the most from your appliance Storing food

The table below contains general guidelines on the storage of food in the refrigerator.

Refrigerator location	Type of food
Crisper bin (salad bin)	<ul style="list-style-type: none"> <li>• Foods with natural preservatives, such as jams, juices, drinks, condiments.</li> <li>• Do not store perishable foods.</li> </ul>
Fridge door	<ul style="list-style-type: none"> <li>• Fruits, herbs and vegetables should be placed separately in the crisper bin.</li> <li>• Do not store bananas, onions, potatoes, garlic in the refrigerator.</li> </ul>
Fridge shelf – bottom Chiller bin	<ul style="list-style-type: none"> <li>• Raw meat, poultry, fish (for short-term storage)</li> </ul>
Fridge shelf – middle	<ul style="list-style-type: none"> <li>• Dairy products, eggs</li> </ul>
Fridge shelf – top	<ul style="list-style-type: none"> <li>• Foods that do not need cooking, such as ready-to-eat foods, deli meats, leftovers.</li> </ul>
Freezer drawer/shelf	<ul style="list-style-type: none"> <li>• Foods for long-term storage.</li> <li>• Bottom drawer/shelf for raw meat, poultry, fish.</li> <li>• Middle drawer/shelf for frozen vegetables, chips.</li> <li>• Top drawer/shelf for ice cream, frozen fruit, frozen baked goods.</li> </ul>

If you require any technical guidance or find that your product is not operating as intended, a simple solution can often be found in the Troubleshooting section of these instructions.

# Getting to know your chest freezer

2

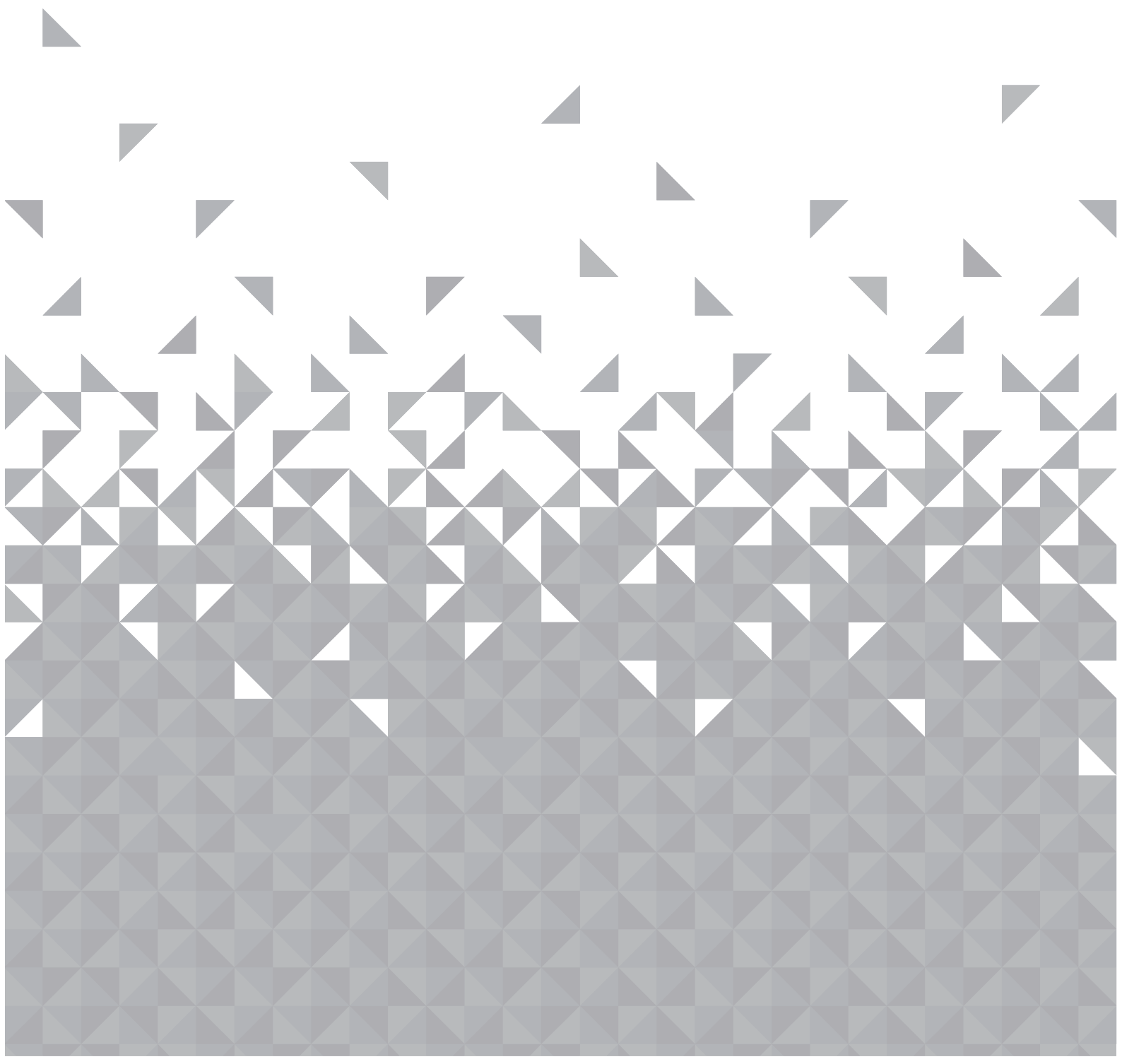



# Getting to know your chest freezer

You'll be up and running in no time

## **Ready? Let's begin...**

Please read these instructions carefully. They contain important information which will help you get the best from your refrigerator and ensure safe and correct installation and operation

If you require any further assistance, our technical experts are happy to help. For full details, refer to the product support section at the end of these instructions.

or online at [www.argos-support.co.uk](http://www.argos-support.co.uk) If you still require further assistance, call one of our experts on 0345 257 7271.

# Getting to know your chest freezer

You'll be up and running in no time

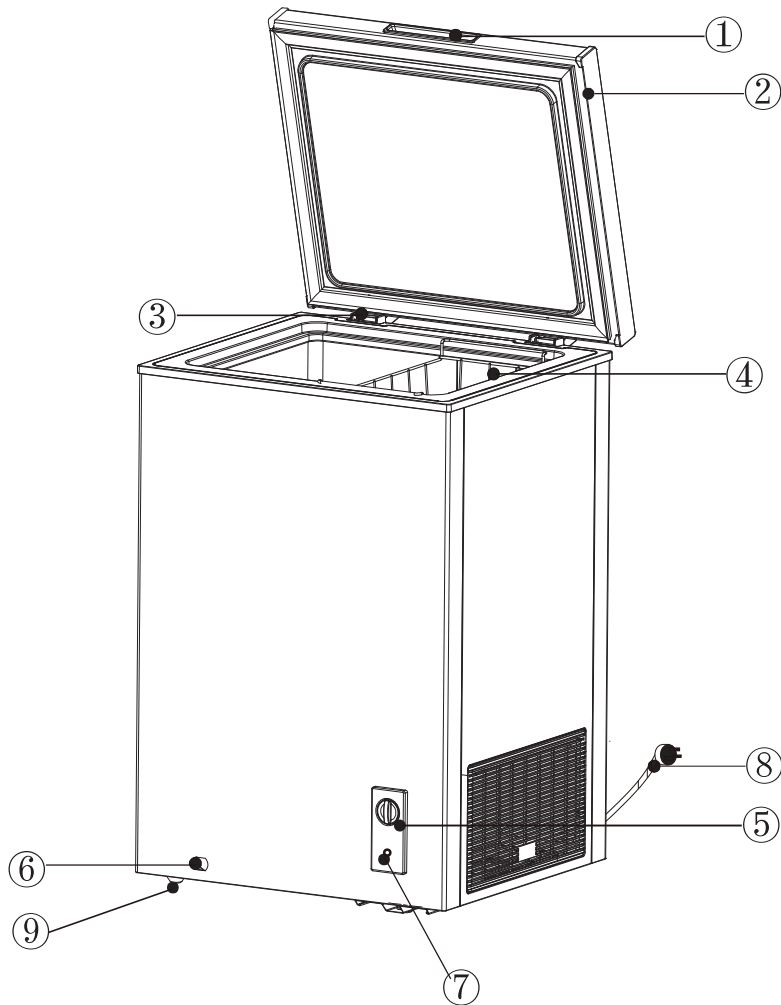

- 1. Door handle
- 2. Door
- 3. Hinge
- 4. Basket
- 5. Temperature knob

- 6. Drain cap
- 7. Power lamp
- 8. Supply cord and plug
- 9. Foot/Castor

## Accessories included

**BUSH** Instruction Manual



Instructions x 1



Scraper x 1

If you require any technical guidance or find that your product is not operating as intended, a simple solution can often be found in the **Troubleshooting** section of these instructions.



# Installing your chest freezer

3

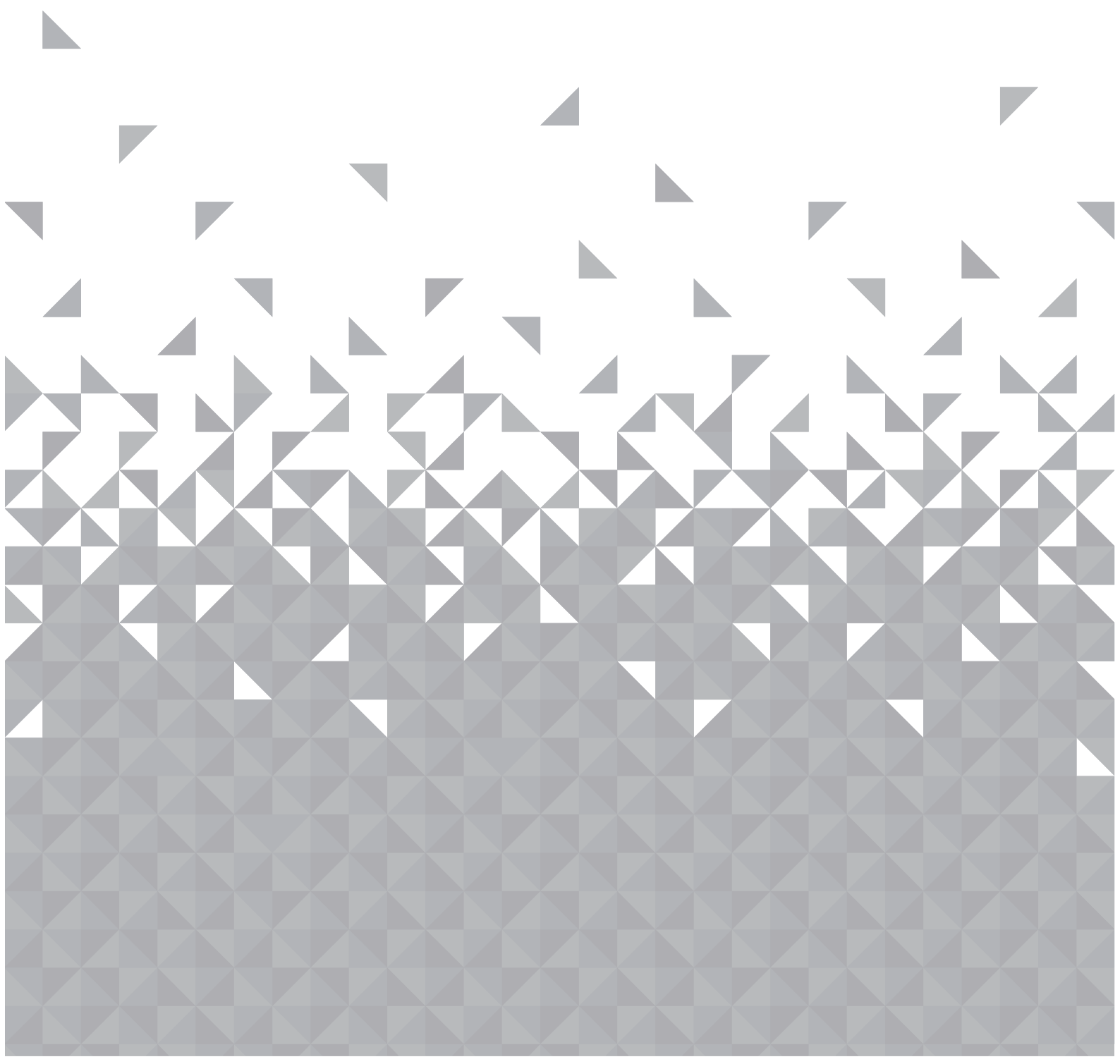

# Installing your chest freezer

## Bringing it all together

### Transportation



**Caution:** 2 people are required to unpack and handle the appliance, it is recommended that gloves are worn.

- The appliance should be transported only in an upright position. Do not tilt the appliance greater than 45°. The packaging as supplied must be intact during transportation.
- After transporting the appliance, leave it for at least 4 hours before switching on to allow the cooling system to settle. Failure to comply could result in damage to the appliance.
- Do not move the appliance by pulling the door or handle as it may damage your flooring and wall coverings etc.
- Ensure the supply cable is not caught under the appliance during and after moving.
- Carefully remove all packaging materials including the foam base, dispose of correctly.

### Installation

- Ensure sufficient spacing is provided for the appliance to be installed. Leave space on both sides (10cm), back (10 cm) ensure proper ventilation.
- Do not place the appliance near a heat source or in direct sunlight.
- Do not put any heavy objects on top of the appliance. It will damage the appliance.
- Do not install the appliance in moist and wet place.
- It should be installed on a smooth surface to avoid excessive vibration and noise.
- Each appliance has a climate class (shown on the rating plate) where it indicates the temperature range of the appliance operation in place. The appliance may not work properly if it is left for a long period at a temperature outside the specified range.
- Refer to section “Care and Maintenance” to prepare your appliance for use.

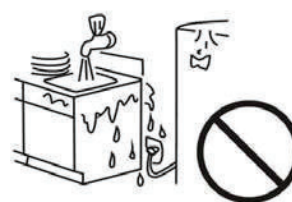
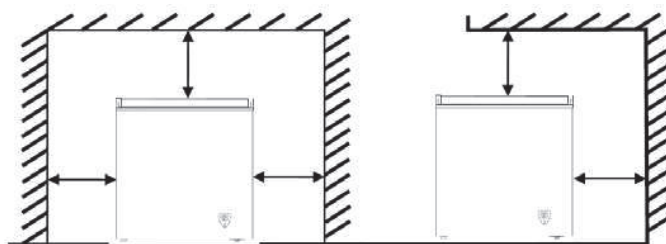

Climate Class	Amb. T. (°C)	Amb. T. (°F)
SN	10 ~ 32°C	50 ~ 90°F
N	16 ~ 32°C	61 ~ 90°F
ST	16 ~ 38°C	61 ~ 100°F
T	16 ~ 43°C	61 ~ 110°F



# Installing your chest freezer

Bringing it all together

## Electrical connection



**Any electrical work that is required to install this appliance MUST be carried out by a qualified electrician.**



**Warning: THIS APPLIANCE MUST BE EARTHED**

**Before making any electrical connections, ensure that:**

- Electrical safety is only guaranteed when the earth system of your house is in accordance with the related local regulations.
- Do not damage the refrigerant circuit.
- Do not bend, stretch or pull the supply cable to avoid electric shock.
- Do not use electrical appliances inside the food storage compartments of the appliance, unless they are of the type recommended by the manufacturer.
- Ensure the power socket is suitable for the maximum power of the machine (fuses in the power circuit must be 13 amp).
- The supply voltage should be the same as that indicated in the technical specifications and the appliance rating plate.
- The appliance should be earthed and in compliance with the applicable law.
- When installed, the power socket must be within easy reach.
- If the socket outlets in your home are not suitable for the plug supplied with this unit check with a qualified electrician for replacement.
- The use of adapters, multiple connectors or extension cables are not recommended.
- The appliance must be connected to a 220-240 volt 50Hz AC supply by means of a three pin socket, suitably earthed and protected by a 13 amp fuse.
- Should the fuse need to be replaced, a 13 amp fuse approved to BS1362/A must be used.
- The plug contains a removable fuse cover that must be refitted when the fuse is replaced. If the fuse cover is lost or damaged, the plug must not be used until a replacement cover has been fitted or the plug is replaced.

- A damaged plug should be cut off as close to the plug body as possible, the fuse should be removed and the plug disposed of safely.

### Plug replacement (UK & Ireland only)

Should you need to replace the plug; The wires in the power cable are coloured in the following way:

Blue – Neutral 'N'

Brown – Live 'L'

Green & Yellow – Earth 'E'

As the colours of the wires in the power cable may not correspond with the coloured markings identifying the terminals in your plug, and proceed as follows:

The green & yellow wire must be connected to the terminal in the plug that is marked with the letter E or by the earth symbol.

The blue wire must be connected to the terminal that is marked with the letter N.

The brown wire must be connected to the terminal that is marked with the letter L.

If power supply cord is damaged, it must be replaced by the manufacturer or its service agent or a similar qualified person in order to avoid a hazard.

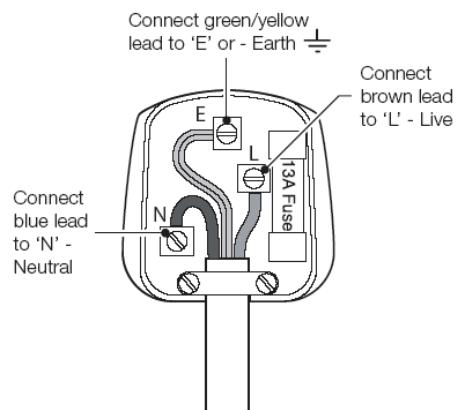



# Using your chest freezer

4

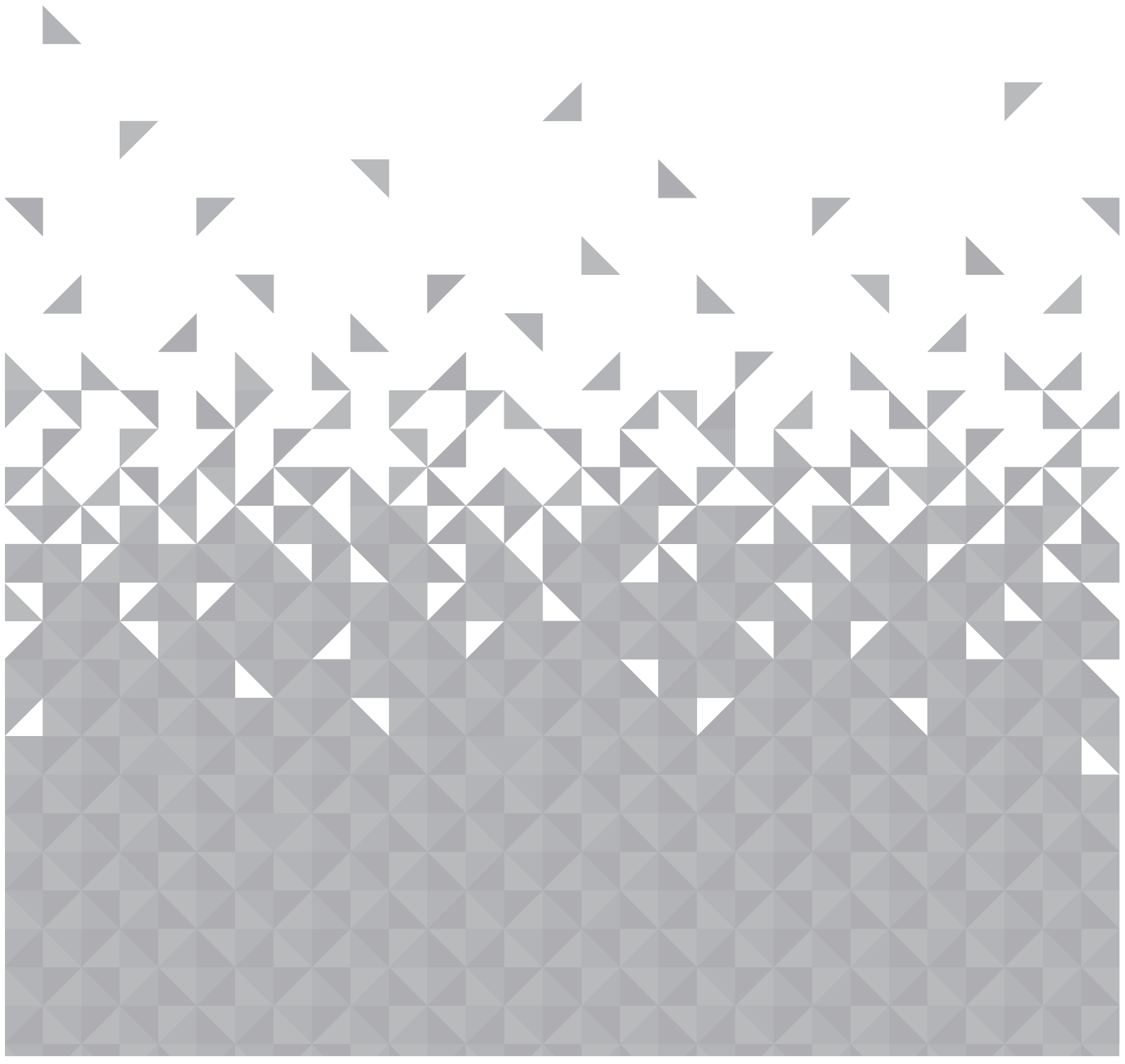

# Using your chest freezer

Getting the most from your appliance

## Before first use

### Final checks before operating the appliance

1. Good air circulation around the appliance positioned.
2. The feet have been adjusted for perfect levelling.
3. Clean the compartment per recommendation in section "Care and Maintenance".
4. Plug in the appliance and power light will come on.



The compressor starts up and in operation may produce some background noise and it is normal, this is not a defect.

## Using your appliance

### 1. Temperature adjustment

- Connect the unit to the mains and then the power indicator will be light up (green colour).

- To lower the internal temperature - rotate the thermostat knob clockwise.

- If the knob is pointing to area with "cooling", the internal temperature will set as cooling zone (between 10°C to 0°C).

- If it is pointing to area with "Freezing", the internal temperature will be set as freezing zone (between -12°C to -24°C).

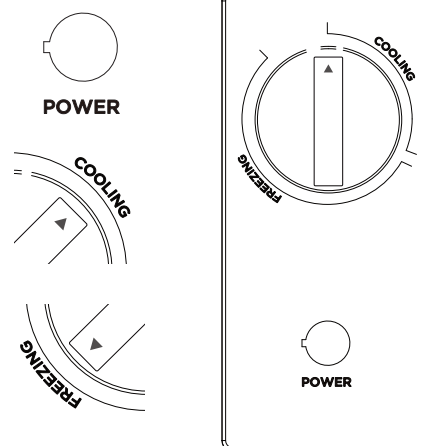

### 2. Indicator light



- Power (Green) indicator - when the unit connected to power the indicator light will be illuminated.

# Using your chest freezer

## Getting the most from your appliance

### Useful information

The following guidelines and recommendations are suggested to obtain the best results and storage hygiene.

- Frequent door openings can cause internal temperature rise so the door shall be closed as soon as possible after use.
- For hygiene reasons, it is always a good practise to pack, wrap and cover the food before storing.
- Food shall cool to room temperature before storing.
- Do not fill the appliance with too much food: cold air must circulate freely for food to be preserved properly.
- Never re-freeze anything that has thawed out unless you cook it again, to kill off harmful bacteria.
- Never re-freeze thawed shellfish.
- Re-seal packs properly after removing items. This prevents drying or 'freezer burn' and a build up of frost on any remaining food.
- The freezer compartment is  4 Star rated and suitable for the freezing and storage of pre-frozen food.
- Check the food packaging for  suggestion before storage.
- A high temperature setting may accelerate food to turn bad, hence increase food waste. Therefore for optimum food preservation, a middle temperature setting is generally the most safe and suitable.

### Energy saving tips

- Place your freezer away from direct sunlight, your oven or any other heat sources. Leave space on both sides (10cm) and back (10cm).
- Higher cold setting will use more energy. Do not set to maximum cold if it is not necessary.
- Frequently open and close door would cause internal temperature rise and it will consume more energy.
- Close the door(s) properly, and make sure the seals and hinges are airtight. Check the seals by putting a sheet of paper between the door and the main body of the fridge. If the paper moves, your seals need replacing.
- Defrost regularly. Accumulated ice layer should not be more than 5 mm thick.
- The pre-set position of basket has already set in the most efficient use of this product.

If you require any technical guidance or find that your product is not operating as intended, a simple solution can often be found in the Troubleshooting section of these instructions.



# Care and maintenance

5

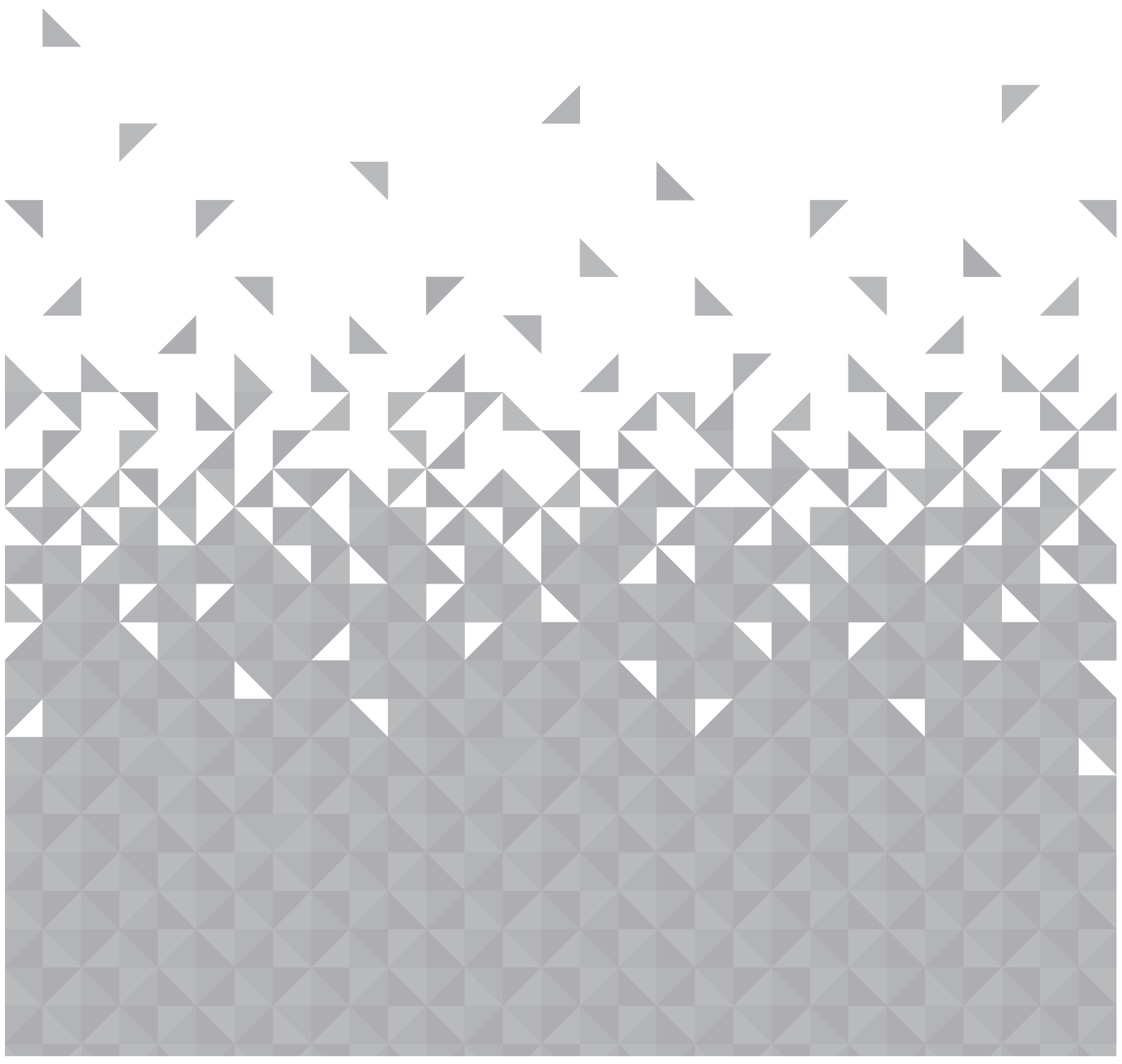

# Care and maintenance

## Looking after your appliance

### General



**Important: Always unplug the appliance from the power socket during cleaning and maintenance.**

- Never use any sharp instruments or abrasive substances, soap, household cleaner, detergent or wax polish for cleaning.
- Use luke warm water to clean the cabinet of the appliance and wipe it dry.
- Never clean the appliance with flammable fluids. It could cause a damage and fire hazard.
- Clean the exterior of the appliance and door seal with a damp cloth and dry it through.
- Avoid water goes in the temperature control box. Clean with a dry cloth only.
- When the appliance is unplugged please wait for 5 minutes before plugging it in again. Otherwise, the compressor will be overloaded.
- Do not store bottled or canned drinks (especially carbonated drinks) in the freezer compartment. Bottles and cans may explode!
- Avoid prolonged touching of frozen food, ice or the inner freezer walls or tubing etc. Risk of frost burns to the skin.
- Dusts behind the refrigerator and on the ground shall be timely cleaned to improve the cooling effect and energy saving.
- The interior of the refrigerator should be cleaned regularly to avoid odor.
- Check the door gasket regularly to make sure there are no debris.
- Please turn off the power before cleaning, remove all food, shelves, drawers, etc.
- Clean the door gasket with mild soap and water.
- Use a soft cloth or sponge to clean the inside of the refrigerator, with two tablespoons of baking soda and a quart of warm water. Then rinse with water and wipe clean, and open the door and dry it naturally before the power is turned on.
- For areas that are difficult to clean in the refrigerator (such as narrow sandwiches, gaps or corners), it is recommended to wipe them regularly with a soft rag, soft brush, etc. and when necessary, combined with some auxiliary tools (such as thin sticks) to ensure no contaminant accumulation in these areas.
- Do not use soap, detergent, scrub powder, spray cleaner, etc., as these may cause odors in the interior of the refrigerator.
- Clean the bottle frame, shelves and drawers with a mild detergent and dry with a soft cloth. Wipe the outer surface of the refrigerator with a soft cloth dampened with soapy water, detergent, etc., and then wipe dry.
- Do not use hard brushes, clean steel balls, wire brushes, abrasives, such as toothpastes, organic solvents (such as alcohol, acetone, banana oil, etc.), boiling water, acid or alkaline items clean refrigerator considering that this may damage the fridge surface and interior. Boiling water and benzene may deform or damage plastic parts.
- Do not rinse with water so as not to affect the electrical insulation properties.

### Defrosting

- The appliance require defrosting once or twice a year when ice layer thickness reaches 5~10mm. Unplug the appliance from the mains before defrosting.
- Remove all frozen food from the freezer and roll it firmly in newspapers. Put it into a container in a cool place for temporary storage.
- Use an ice scraper or similar tool to remove the ice layer. This process can be speed up by placing a pot of warm water inside the freezer.
- Open the drain hole cap to empty the defrosting water.
- Clean the freezer according to the steps above.
- Turn on the freezer and set to maximum temperature. Refill the frozen food to freezer.
- This process should be completed within 2 hours.

or online at [www.argos-support.co.uk](http://www.argos-support.co.uk) If you still require further assistance, call one of our experts on 0345 257 7271.



# Care and maintenance

## Looking after your appliance

### Power failure

In case there is a power failure, you should contact the electricity supply company and take the following actions:

If it is last within 24 hours, keep the doors closed. This will allow the stored food to stay cold as long as possible.

If it is last more than 24 hours, it is advised to empty the freezer compartment and temporarily store the food in a portable freezer or using artificial ice packs. Try to use up the food which is more easily perishable.

Remarks: Full appliance will stay cold longer than a partially filled one.

If ice crystals are still visible on the food, it may be frozen again, although flavour and aroma may be affected. If food is found to be in a poor condition, it is best to throw it away.

#### Short vacation

There is no need to disconnect the appliance from the mains if you will be away for two to three weeks. Use up the perishable food

#### Long vacation



Remove all the food if you are away for three weeks or more. Unplug the appliance and leave the doors open to provide air circulation to prevent odour and mould.

### Moving your appliance

#### Moving

Refer to section "Transportation" under "Installation"

#### Technical specification

Model	BECF99L/MECF99W	BECF142L	BECF198L
Energy efficiency class	F	F	F
Energy consumption – Kwh/year	211	228	250
Net storage – volume fresh food (litres)	0	0	0
Net storage – volume frozen food (litres)	99	142	198
Total net storage (litres)	99	142	198
Frozen food compartment rating	4 Star 	4 Star 	
Climate class	SN/N/ST/T	SN/N/ST/T	
Operating noise level dB(A)	38	41	41
Minimum Operating Temperature	10 C°	10°C	10°C
Temperature rise value(min)	1020	900	1260
Product Dimensions (mm)	545x495x850	632x550x850	816x550x850

The model information can be retrieved using the QR-code reported in the energy label. The label also includes the model identifier that can be used to consult the portal of the registry at <https://eprel.ec.europa.eu>

This product contains a light source of energy efficiency class G (if present).

We apologise for any inconvenience caused by any minor inconsistencies in these instructions, which may occur as a result of product improvements and development.

# Care and maintenance

Looking after your appliance

## Technical specification



This appliance complies with the following EEC directives:  
2014/35/EU Low voltage directive  
2014/30/EU EMC directive

## Disposal information



The symbol on the product or its packaging indicates that this product may not be treated as household waste. Instead it should be handed over to the applicable collection point for the recycling of electrical and electronic equipment. By ensuring this product is disposed of correctly, you will help prevent potential negative consequences for the environment and human health, which could otherwise be caused by inappropriate waste handling of this product. For more detailed information about recycling this product, please contact your local council office, your household waste disposal service or the shop where the product was purchased.

**Remember: Old fridges must be disposed of carefully - older models contain CFC gases that are harmful - if in doubt, contact your local council for details on how to dispose of an old fridge.**





# Product support

6

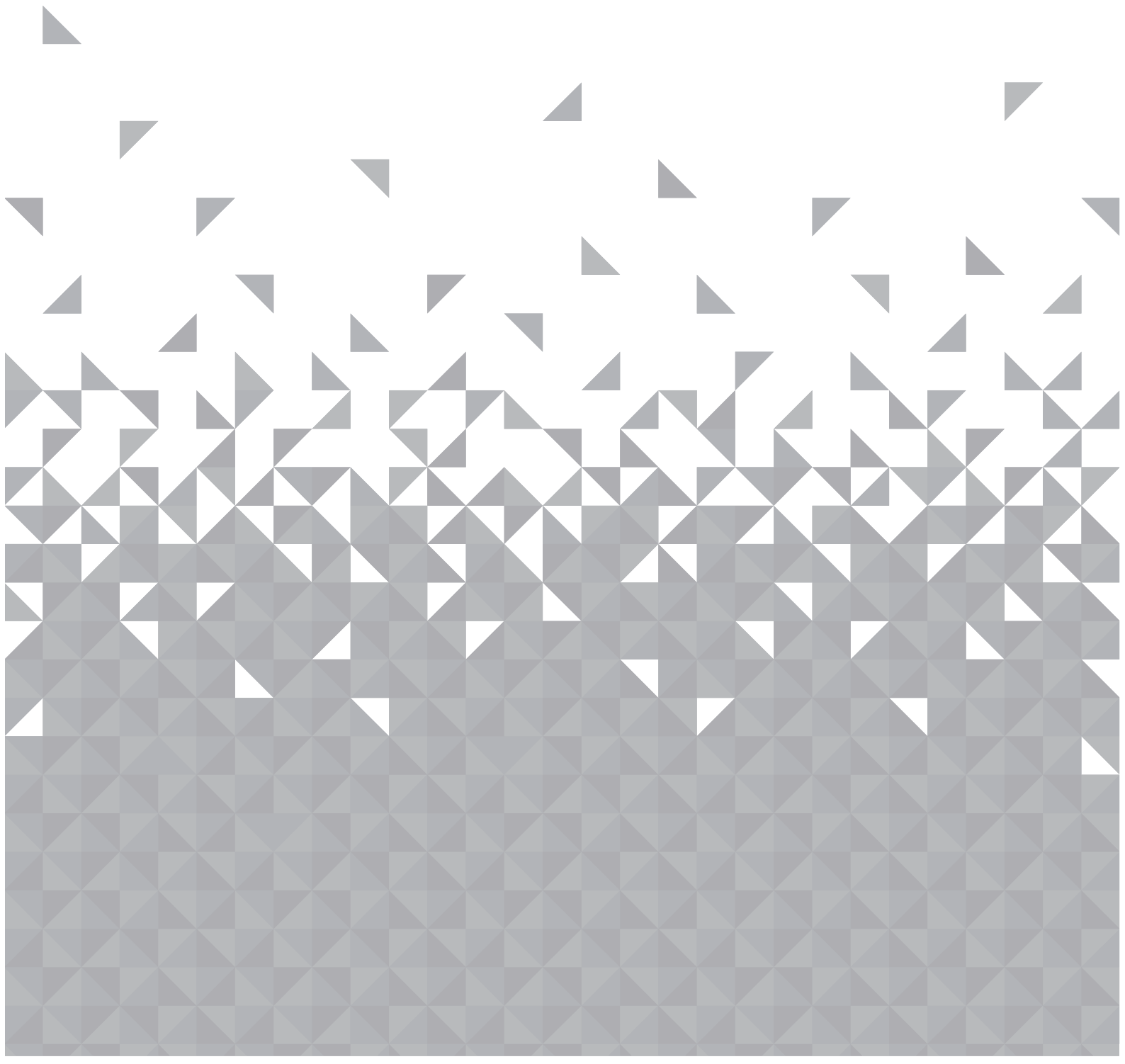

# Product support

Help is always at hand

## Troubleshooting

If you have a problem with your product, these questions may be able to assist you?

### Question- Appliance does not work.

Answer

Appliance is not switched on - Switch on the appliance.

Mains plug is not plugged in or is loose. -Insert mains plug.

Fuse has blown or is defective - Check fuse, replace if necessary.

Socket is defective - Mains malfunctions are to be corrected by an electrician.

### Question - Appliance cools too much.

Answer

Temperature is too cold - Adjust the thermostat dial to a warmer setting.

### Question - The food is too warm.

Answer

Temperature is not properly adjusted - Adjust the thermostat to a cooler setting.

Door was open for an extended period - Open the door only as long as necessary.

A large quantity of warm food was placed in the appliance - Adjust the thermostat to a cooler setting. Cool warm food before placing in the chest freezer.

The appliance is near a heat source - Position the chest freezer away from a heat source.

### Question-Heavy build up of frost, possibly also on the door seal.

Answer

Door seal is not air tight - Carefully warm the leaking sections of the door seal with a hair dryer(not hotter than approx 50 degree). At the same time shape the warmed door seal by hand such that it sits correctly.

### Question - Appliance is making unusual noises

Answers

Appliance is in contact with wall or other objects. - Push appliance away a short distance.

A part at the back of the appliance is in contact with another appliance part or wall - - Gently bend this part away carefully if necessary.

If you require any technical guidance or find that your product is not operating as intended, a simple solution can often be found in the Troubleshooting section of these instructions.

# Product support

Help is always at hand

## Help and assistance

If you require any technical guidance or find that your chest freezer is not operating as intended, a simple solution can often be found in the **Troubleshooting** section of these instructions or online at [www.bush-support.com](http://www.bush-support.com)

If you still require further assistance, call one of our experts on **0345 257 7271\***. To help give us give you a fast and efficient service please have the following information ready.

Model Ref.

You can find these on the rating plate - a small information panel (usually a sticker or metal plate) on the rear of your appliance

Serial number

Date of purchase

This will be shown on your receipt

Local call rates applies\*

Lines open 8am-7pm Monday to Saturday and 10am-4pm Sunday.

\*Calls to Bush enquiry lines may attract a charge and set up fee from residential lines depending on your call plan/tariff. Mobile and other providers costs may vary, see [www.bt.com/pricing](http://www.bt.com/pricing) for details.

For Security and training purposes, telephone calls to and from customer service centres maybe recorded and monitored. Calls from Republic of Ireland will attract international call charges.



This appliance complies with the following EEC directives:  
2014/35/EU Low voltage directive  
2014/30/EU EMC directive

Spare Parts Supply

To order spare parts, please contact our customer helpline: 0345 257 7271. The original spare parts for some specific components are available for a period of 10 years, based on the type of component, from the placing on the market of the last unit of the model.

If you require any technical guidance or find that your product is not operating as intended, a simple solution can often be found in the **Troubleshooting** section of these instructions,

## Product support

Help is always at hand

# BUSH

### Call us now and activate your 12 month guarantee

Thank you for choosing Bush. Your new product is guaranteed against faults and breakdowns for 12 months. Don't forget to register it with us today so we can provide you with our best possible after-sale service and useful updates.

**[www.bushregistration.co.uk](http://www.bushregistration.co.uk)**

**FREEPHONE\***

**0800 597 8548**

Lines are open 8am-8pm, 365 days a year. \*Call may be recorded and monitored.

### Your Bush Guarantee

This product is guaranteed for twelve months from the date of original purchase. Any defect that arises due to faulty materials or workmanship will be repaired free of charge (or if applicable the product will be replaced or the purchase price refunded) where possible during this period by the dealer from who your purchased unit.

#### The guarantee is subject to the following provisions:

- The guarantee does not cover accidental damage, misuse cabinet parts, knobs or consumable items.
- The product must be correctly installed and operated in accordance with the instructions contained in the manual
- It must be used solely for domestic purposes. The guarantee will be rendered invalid if the product is re-sold or has been damaged by inexpert repair.
- Specifications are subject to change without notice.
- Bush disclaim any liability for loss or damage arising from the breakdown of the product
- This guarantee is in addition to and does not diminish your statutory or legal rights

#### Important Data Protection Information

To find out how we and Domestic & General Insurance Plc use your data please refer to the guarantee registration material or visit [www.bushregistrations.co.uk](http://www.bushregistrations.co.uk).

or online at [www.argos-support.co.uk](http://www.argos-support.co.uk) If you still require further assistance, call one of our experts on 0345 257 7271.









# BUSH



**Contact:**

[www.bush-support.com](http://www.bush-support.com)

Helpline: 0345 257 7271