

2 Tier Internal Wrobe Shoe Rack

Assembly Instructions - Please keep for future reference

932/7722

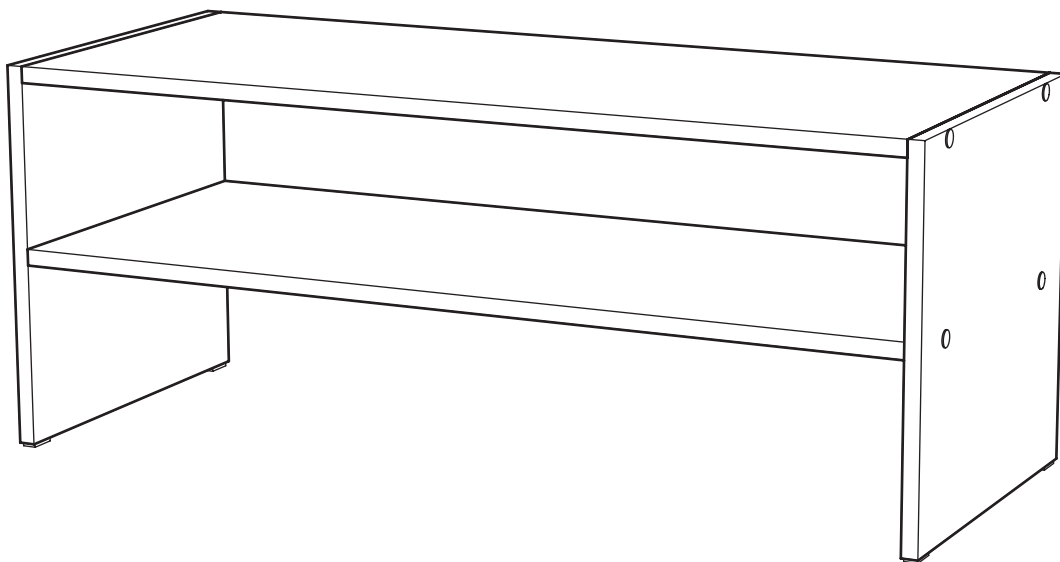

Dimensions

Width - 70cm

Depth - 28cm

Height - 28cm

Important - Please read these instructions fully before starting assembly

If you need help or have damaged or missing parts, call the **Customer Helpline: 08456 400800**



Safety and Care Advice

Important - Please read these instructions fully before starting assembly

- Check you have all the components and tools listed on pages 2 and 3.
- Remove all fittings from the plastic bags and separate them into their groups.
- Keep children and animals away from the work area, small parts could choke if swallowed.
- Make sure you have enough space to layout the parts before starting.

- Do not stand on the panels, this could cause damage.
- Assemble the unit as close to its final position (in the same room) as possible.
- Assemble on a soft level surface to avoid damaging the unit or your floor.
- Parts of the assembly will be easier with 2 people.



- We do not recommend the use of power drill/ drivers **for inserting screws**, as this could damage the unit. Only use hand screwdrivers.
- Dispose of all packaging carefully and responsibly.
- **Warning:** The unit weighs approximately 4.8kgs. **Please lift with care.**

Care and maintenance

- Only clean using a damp cloth and mild detergent, do not use bleach or abrasive cleaners.
- Assembly to be carried out by the competent adult only.
- From time to time check that there are no loose screws on this unit.
- During assembly children should be kept away from the product due to the potential risk of injury.
- This product should not be discarded with household waste. Take to your local authority waste disposal centre.
- Do not use this item if any components are missing or damaged.

Components - Panels

If you have damaged or missing components, call the **Customer Helpline:08456 400800**

Please check you have all the panels listed below



1 Shelf x 2 (67.6 x 28cm)

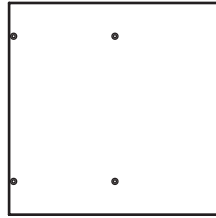

2 Side x 2 (28 x 28cm)

Components - Fittings

Please check you have all the fittings listed below

Note: The quantities below are the correct amount to complete the assembly. In some cases more fittings may be supplied than are required.



A 45mm Screw x 8



B Cap x 8

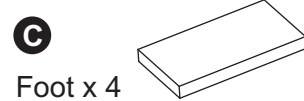

C Foot x 4

Tools required



Phillips screwdriver
(medium & large)



Small
hammer

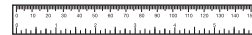

Ruler/tape
measure

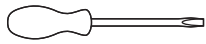

Flatblade screwdriver
(medium)

Ruler - Use this ruler to help correctly identify the screws



Assembly Instructions

Step 1

Fitting the shelves

a: Use Screws **A** to fix Shelves **1** onto Side **2**. Use Caps **B** to cover holes on the Side **2**.

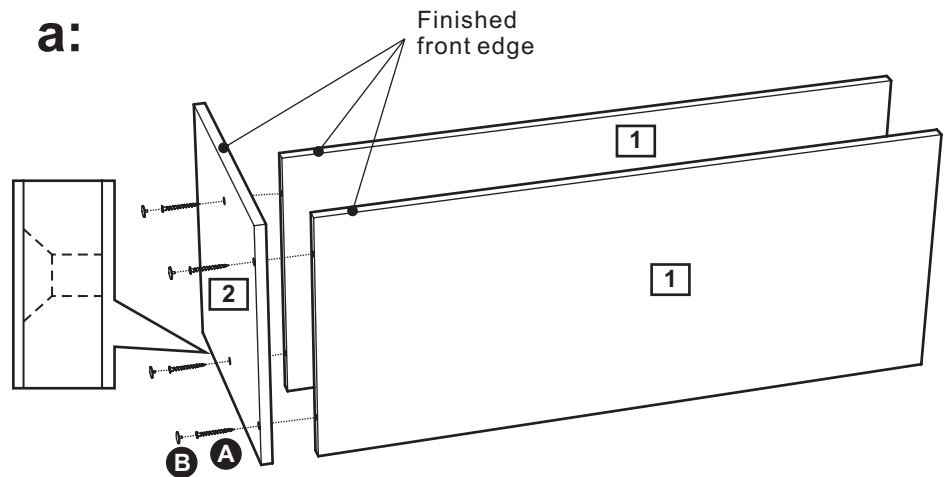

b: Use Screws **A** to fix Side **2** onto the unit. Use Caps **B** to cover holes on the Side **2**.

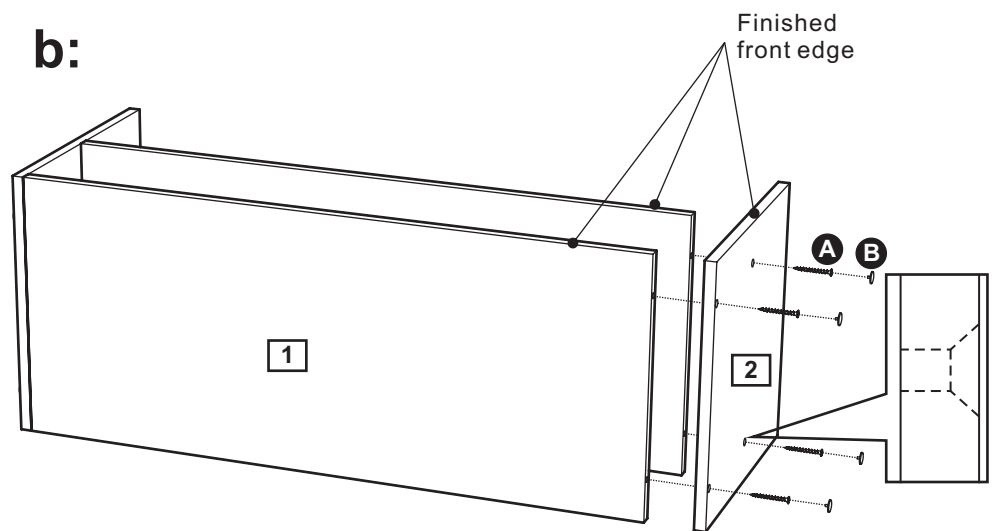

c: Stick Feet **C** onto the unit.

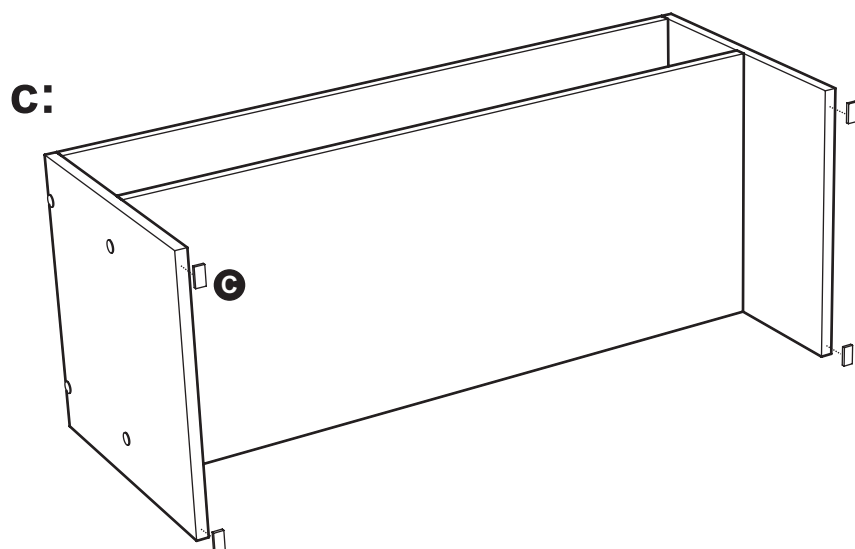

Assembly is complete.

If you need help or have damaged or missing parts, call the **Customer Helpline : 08456 400800**