

# Storage Cabin Bed

Thank you for purchasing this product. Before starting assembly we suggest you spend a short time reading through this leaflet, then follow the simple step by step guide.  
Two people are needed to assemble this product.

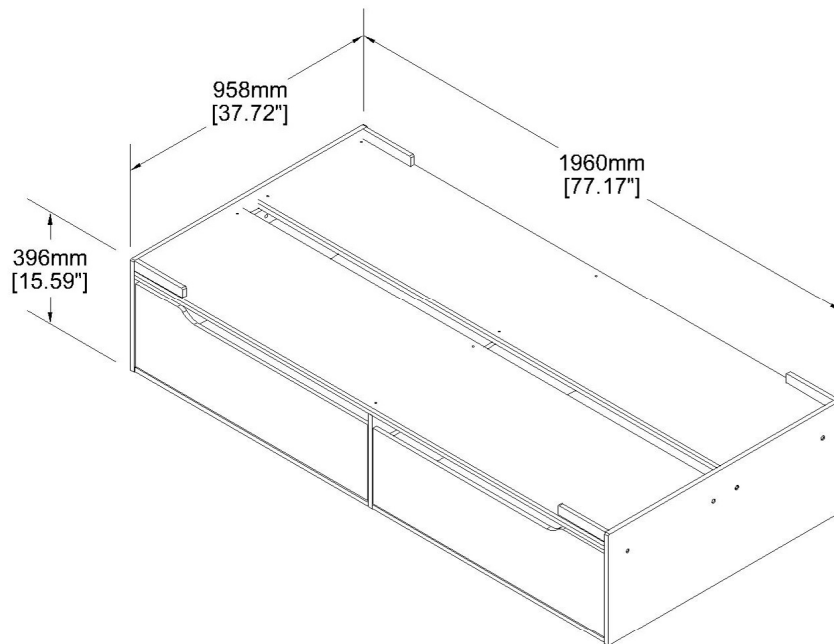

808/3610

882/6815

916/9313

## **TOP TIPS BEFORE YOU START !**

## **IMPORTANT- READ CAREFULLY- RETAIN FOR FUTURE REFERENCE**

1. Please check that all parts & hardware are present before you start the assembly of your furniture.
2. For ease and speed of assembly, we recommend that before you commence each step of the assembly, Please identify all the parts required for that step.
3. We recommend that where possible, all items are assembled near to the area in which they will be placed in use, to Avoid moving the product unnecessarily once assembled.
4. For the protection of your furniture, particularly items of high gloss finish, we recommend that the product is placed on a Protected surface during assembly to prevent any damage.
5. During assembly please take care not to over-tighten any fittings, as this may damage the product.

## **CARE AND MAINTENANCE OF YOUR FURNITURE**

- Please periodically check all fittings and re-tighten as necessary.
- To clean your item, please use a damp cloth and wipe clean.
- Never allow any kind of liquid to remain on your furniture. Absorption can cause wood to warp or finishes to de-laminate.
- Please do not place hot items (e.g hot drinks) directly on the wood surface.
- Please do not drag or pull your furniture.

## **IMPORTANT INFORMATION**

1. Thickness of mattress should not exceed 150mm.
2. Children should be discouraged from playing on top of this bed
3. The bed should be checked periodically by the owner to ensure that the components are maintained in the correct position and that all connectors are tight

**Important – Please read these instructions fully before starting assembly**

If you need help or have damaged or missing parts, call the Customer Helpline: 0345 640 0800

# Tools Required For Assembly

FlatHead  
Screwdriver

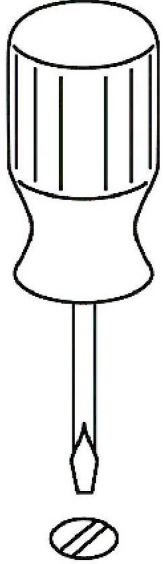

Phillips Screwdriver

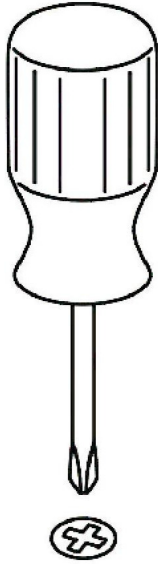

DO NOT USE POWER TOOLS TO ASSEMBLE THIS PRODUCT. USE OF POWER TOOLS WILL INVALIDATE ANY CLAIM AND MAY DAMAGE THIS PRODUCT MAKING IT UNSAFE.



Approximately 1 hour 30 min



2 People Required

Rubber Hammer

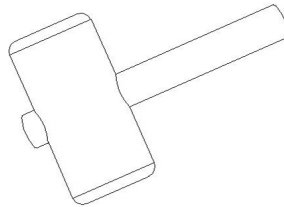

Measure

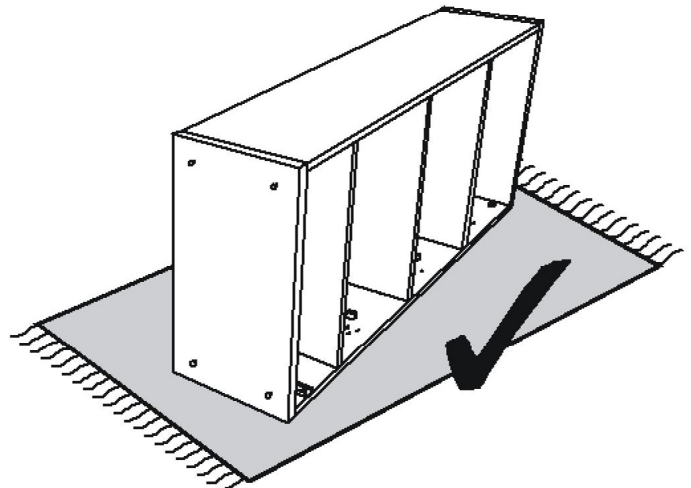
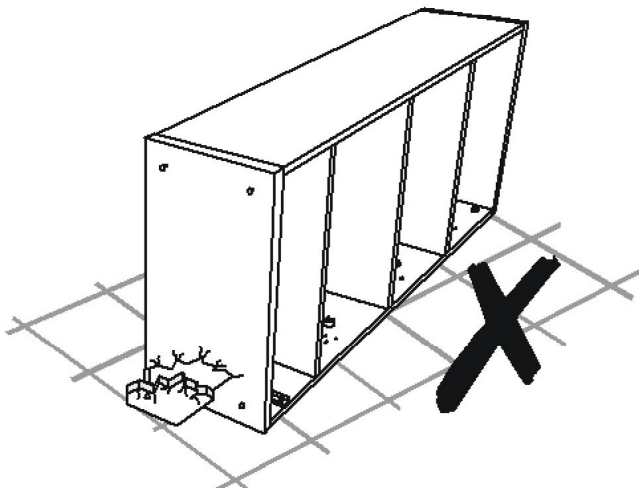
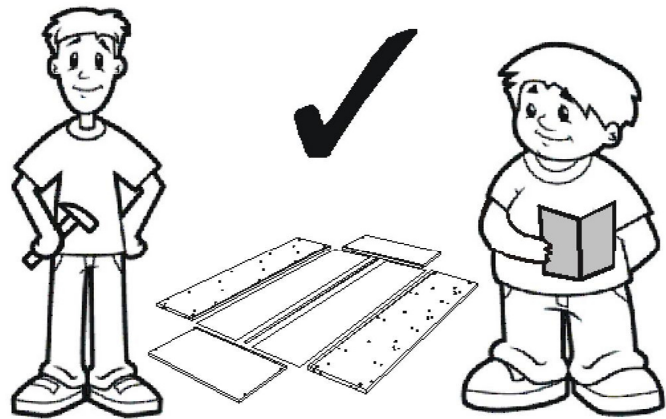
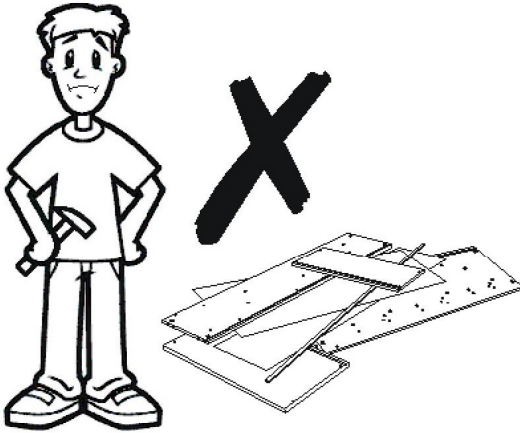
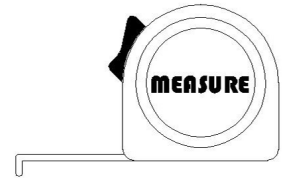

## Carton 1 of 2





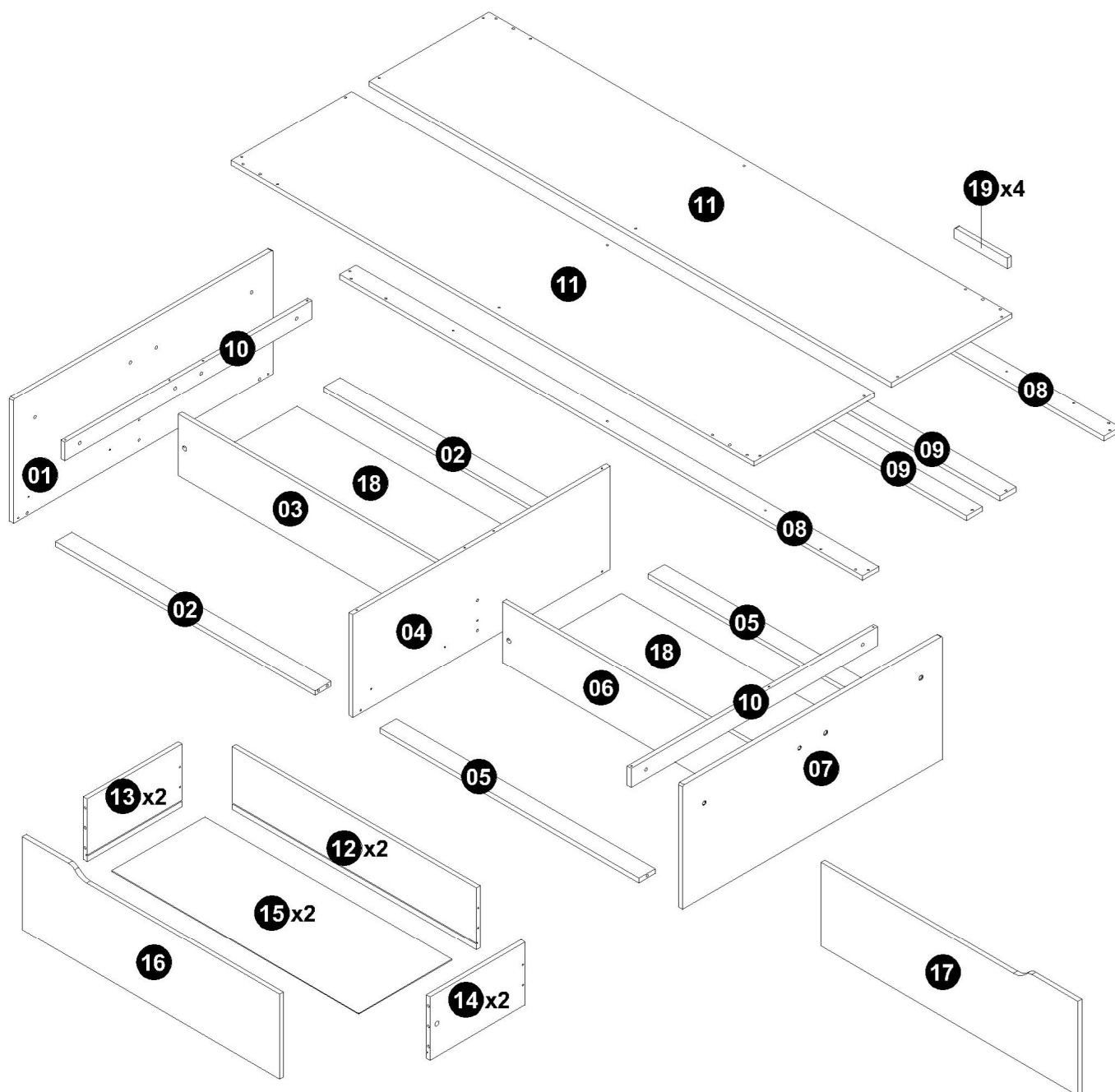







## Carton 2 of 2

No.	Part Name	Pcs	No.	Part Name	Pcs
02	Bottom Panel	2	01	Left End Panel	1
03	Center Support Panel	1	04	Movable Panel	1
05	Bottom Panel	2	07	Support Panel	1
06	Center Support Panel	1	12	Back Panel (Drawer)	2
08	Support Panel	2	13	Left Panel (Drawer)	2
09	Support Panel	2	14	Right Panel (Drawer)	2
10	Support Panel	2	16	Front Panel (Drawer) Left	1
11	Base Panel	2	17	Front Panel (Drawer) Right	1
15	Bottom Panel (Drawer)	2	<b>Assembly Instructions + Fitting List</b>		
18	Bottom Panel	2			
19	Upper Panel	4			

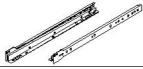

## Carton 2 of 2

### Fitting List

No.	Part Name		Pcs
A	Cam Stud (small)		16
B	Cam		16
C	M8 x 25mm PVC Dowel		24
D	M6 x 50mm JCBCW Screw		20
E	38mm Chipboard Screw		8
F	25mm Chipboard Screw		4
G	22mm Chipboard Screw		8
H	14mm Chipboard Screw		19
J	14" Drawer Slide (SJ)		2 sets
K	PVC Back Support		8
L	M6 x 20mm Allen Bolt		8
M	M6 JCN Nut		8
N	M6 Allen Wrench		2
P	Sticker		8

### Caution

There are many small components used in the construction of this unit. These loose items should be kept away from young children whilst assembling your unit. As an extra precaution, screw cover caps should be permanently fixed in position. (Where applicable)

### USEFUL HINTS & TIPS

Two people will be required to assemble this unit

Please keep this assembly instruction for future reference



1

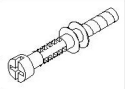

A x 9



H x 11

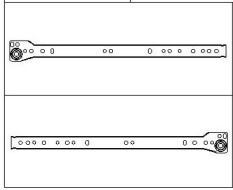

J x 2 sets

To Assembly the Drawer Slide, Please Follow Step as Below

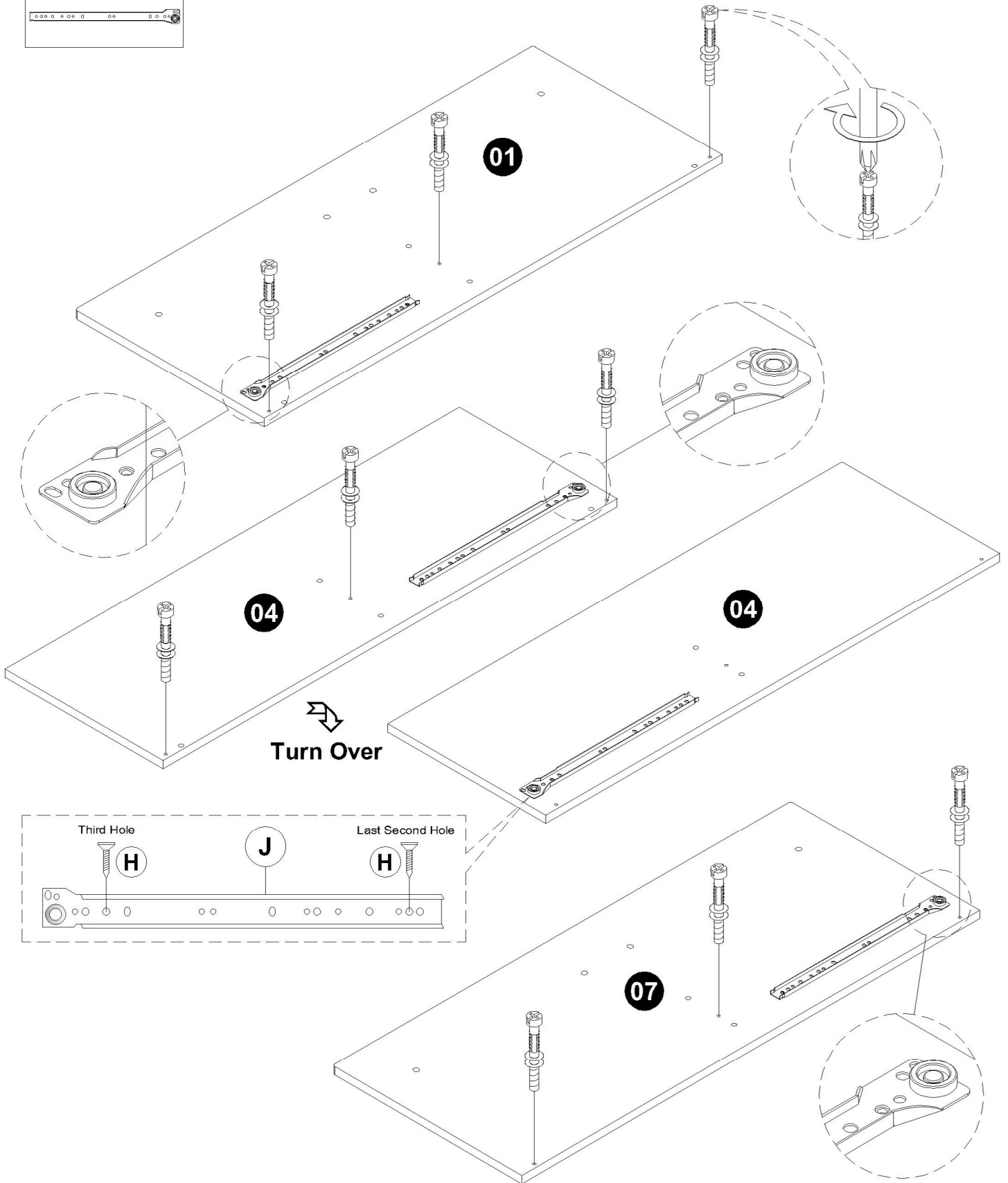
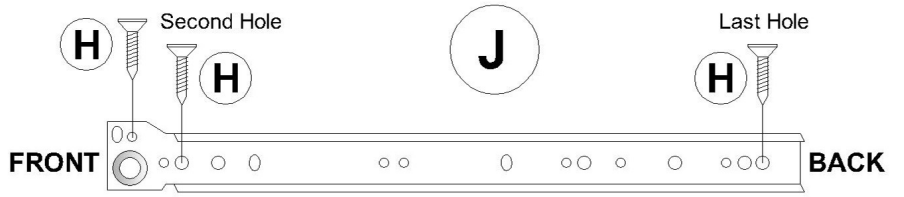

2



B x 12



C x 16

**WHEN FITTING CAMS**

ENSURE STARTING POSITION IS CORRECT  
BEFORE YOU INSERT CONNECTING BOLT  
TURN CLOCKWISE UNTIL SECURE



↑  
CORRECT



WRONG

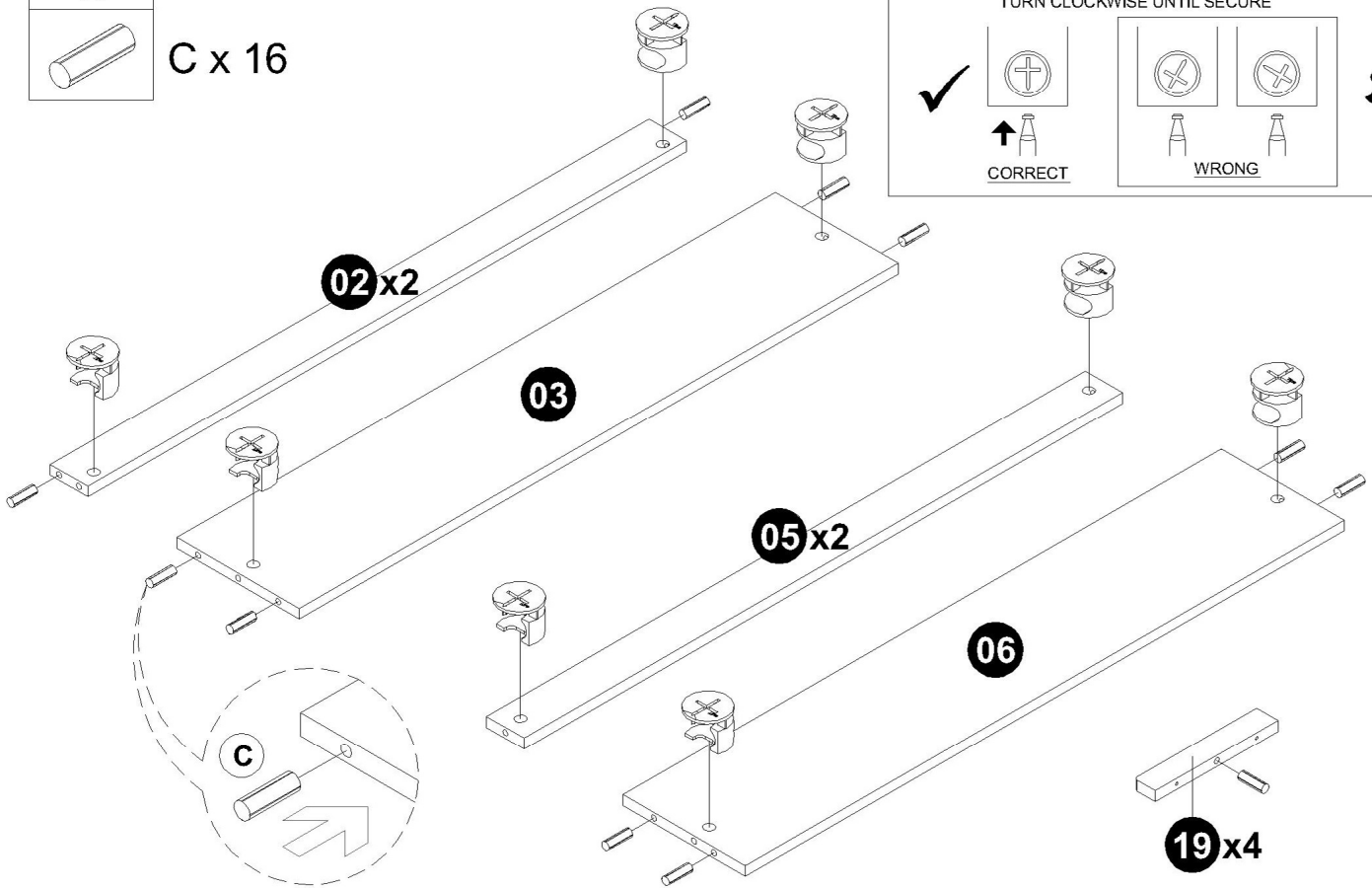

3

4

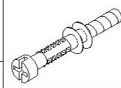

A x 3

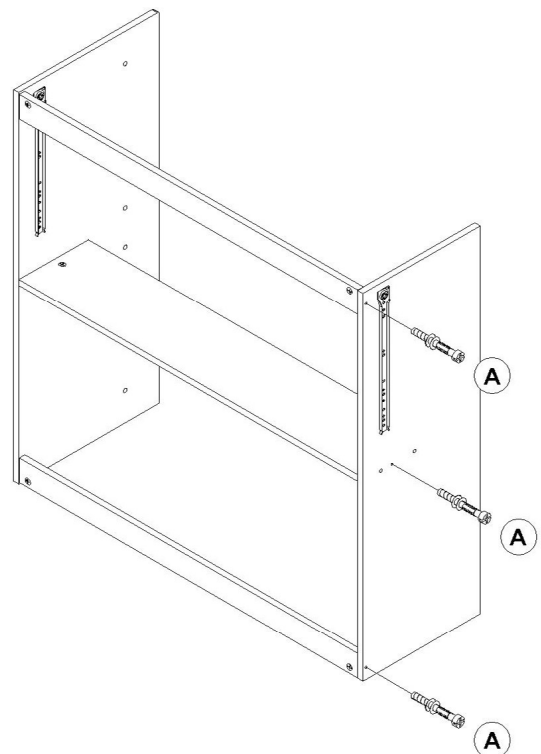
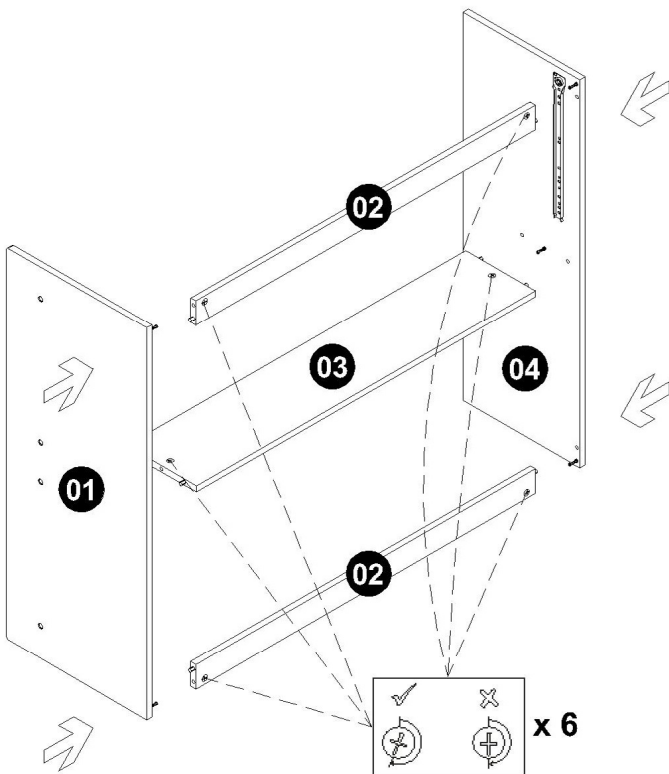

5

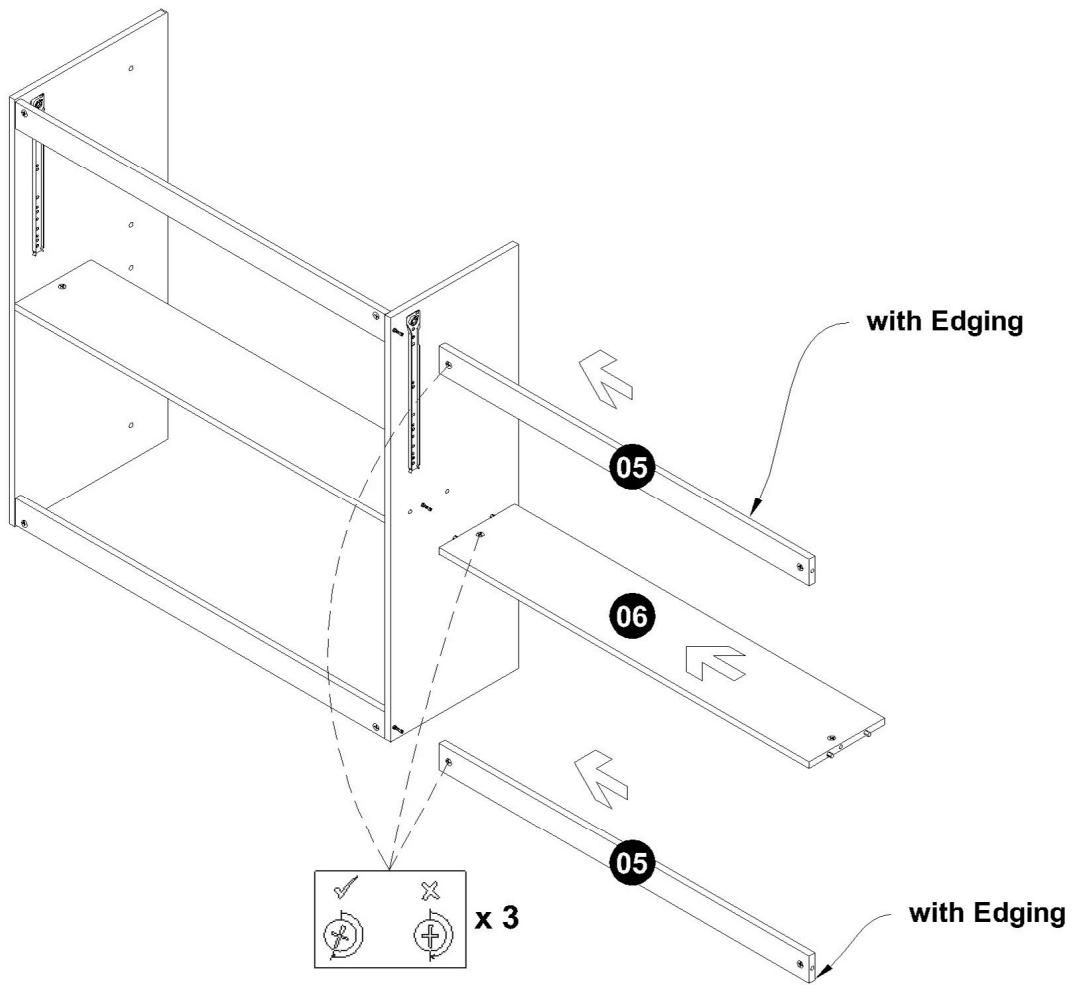

6

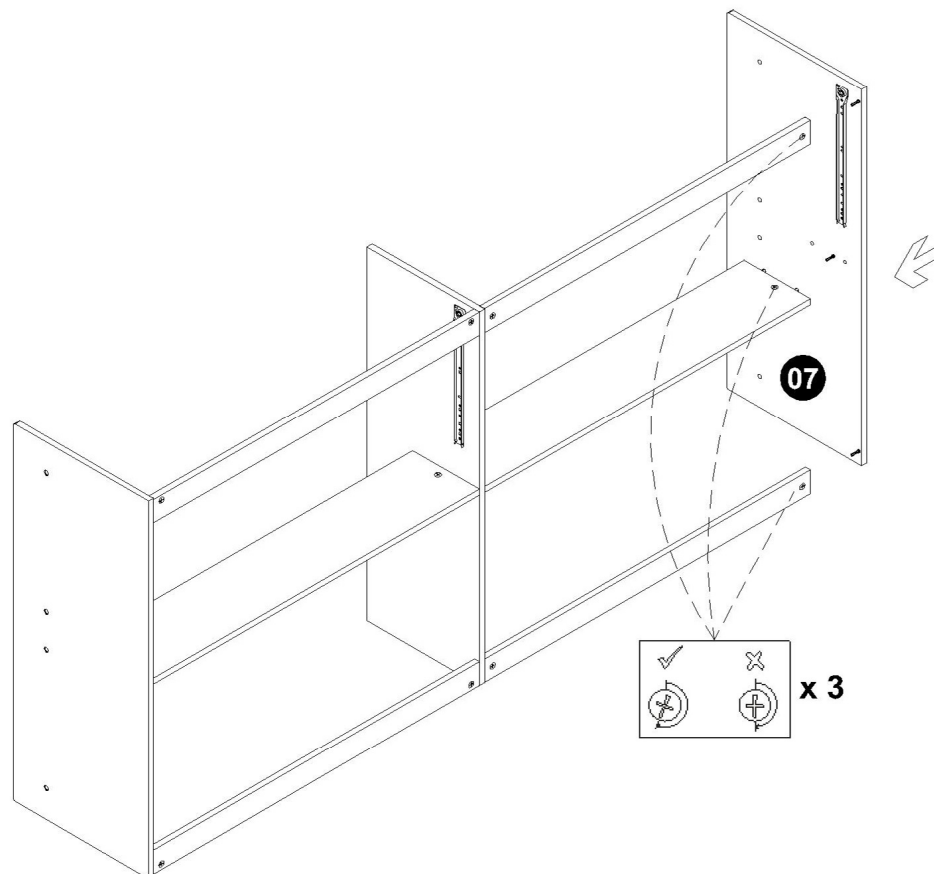

7



L x 8



M x 8

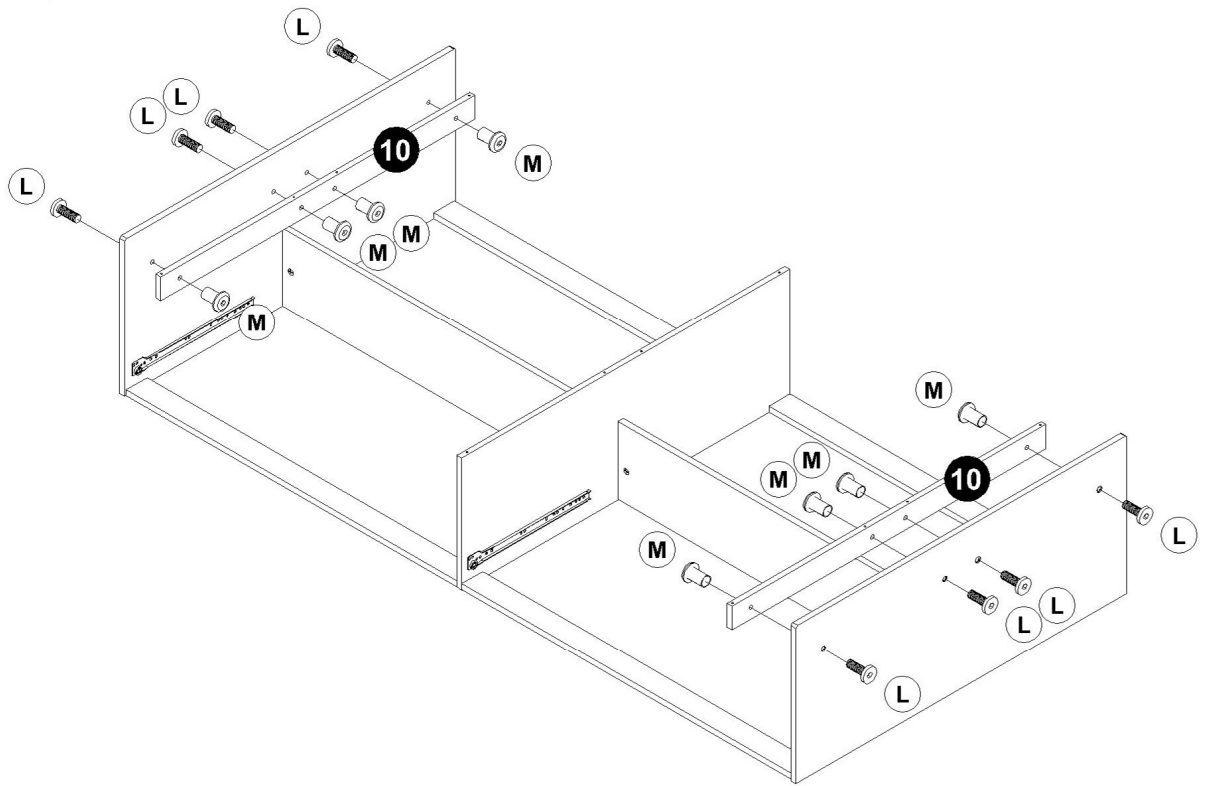

8



F x 4

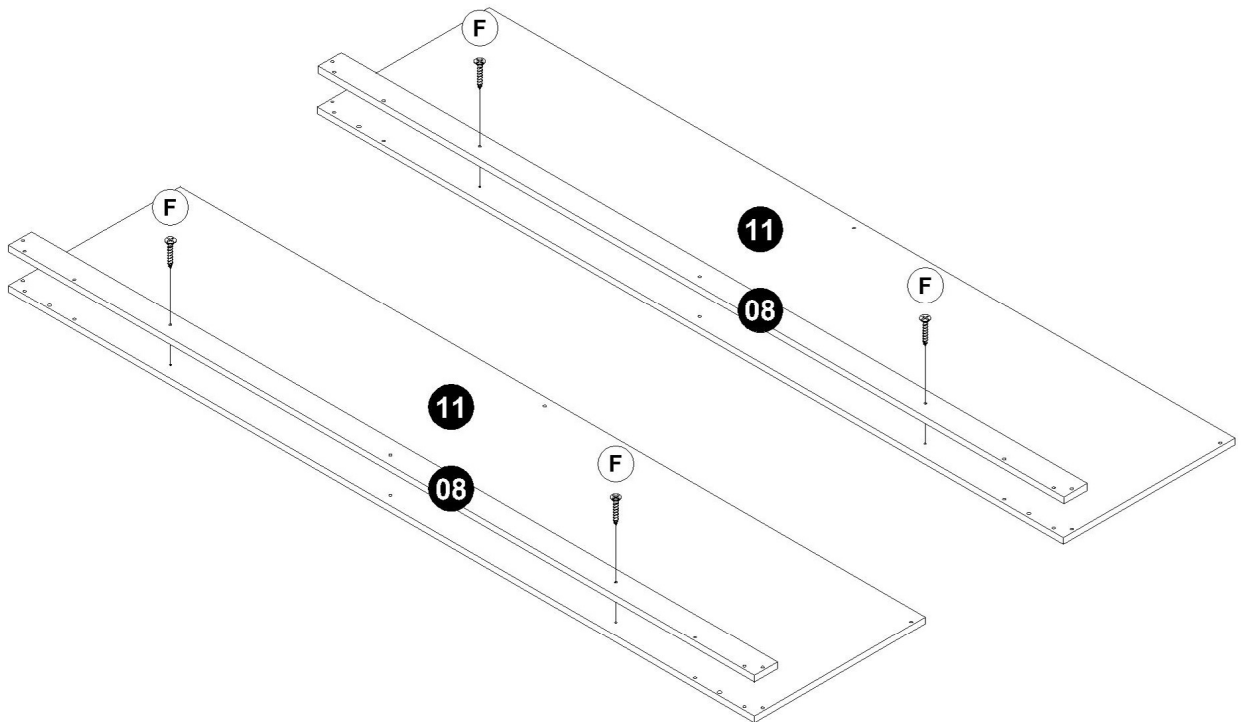

9



D x 12

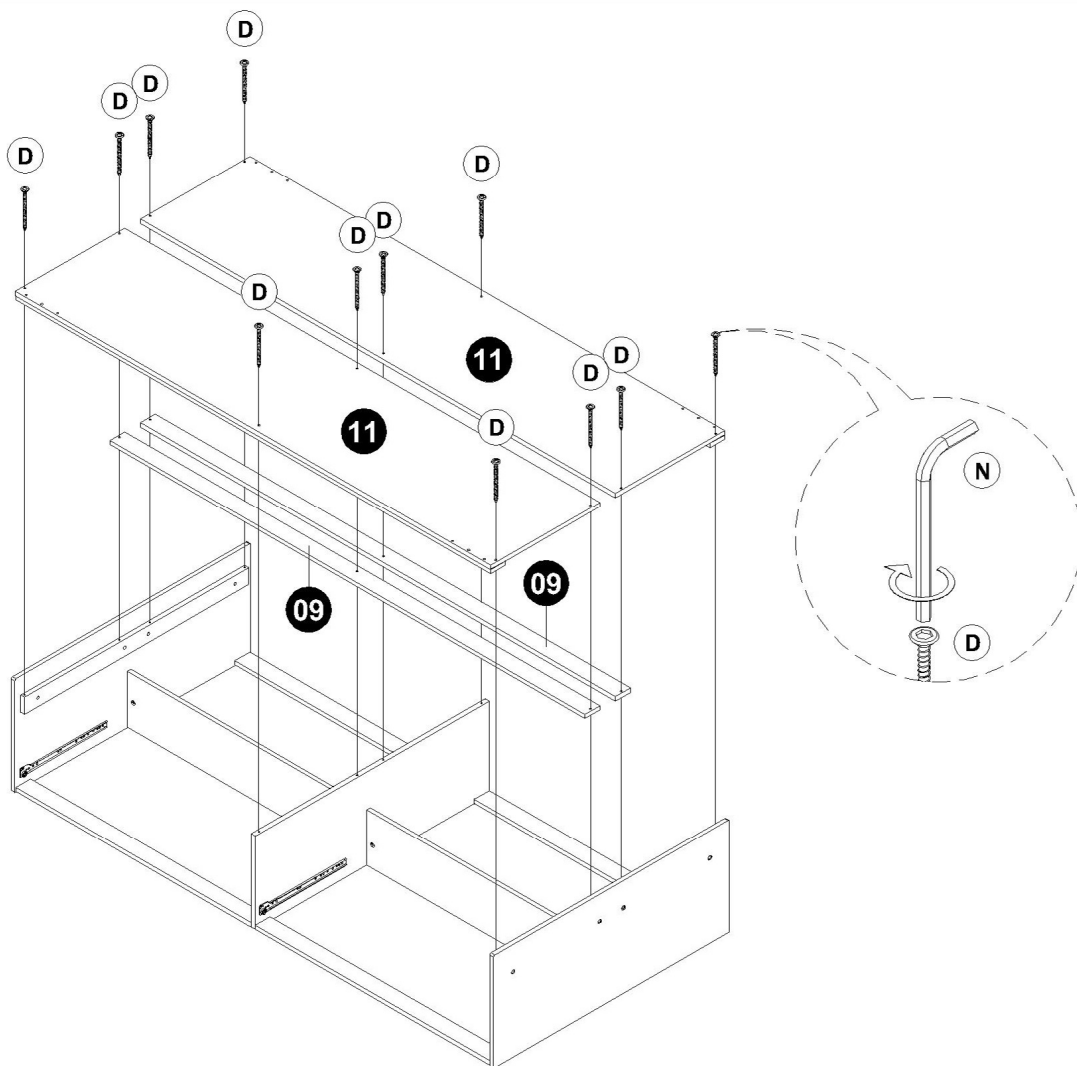

10



D x 8

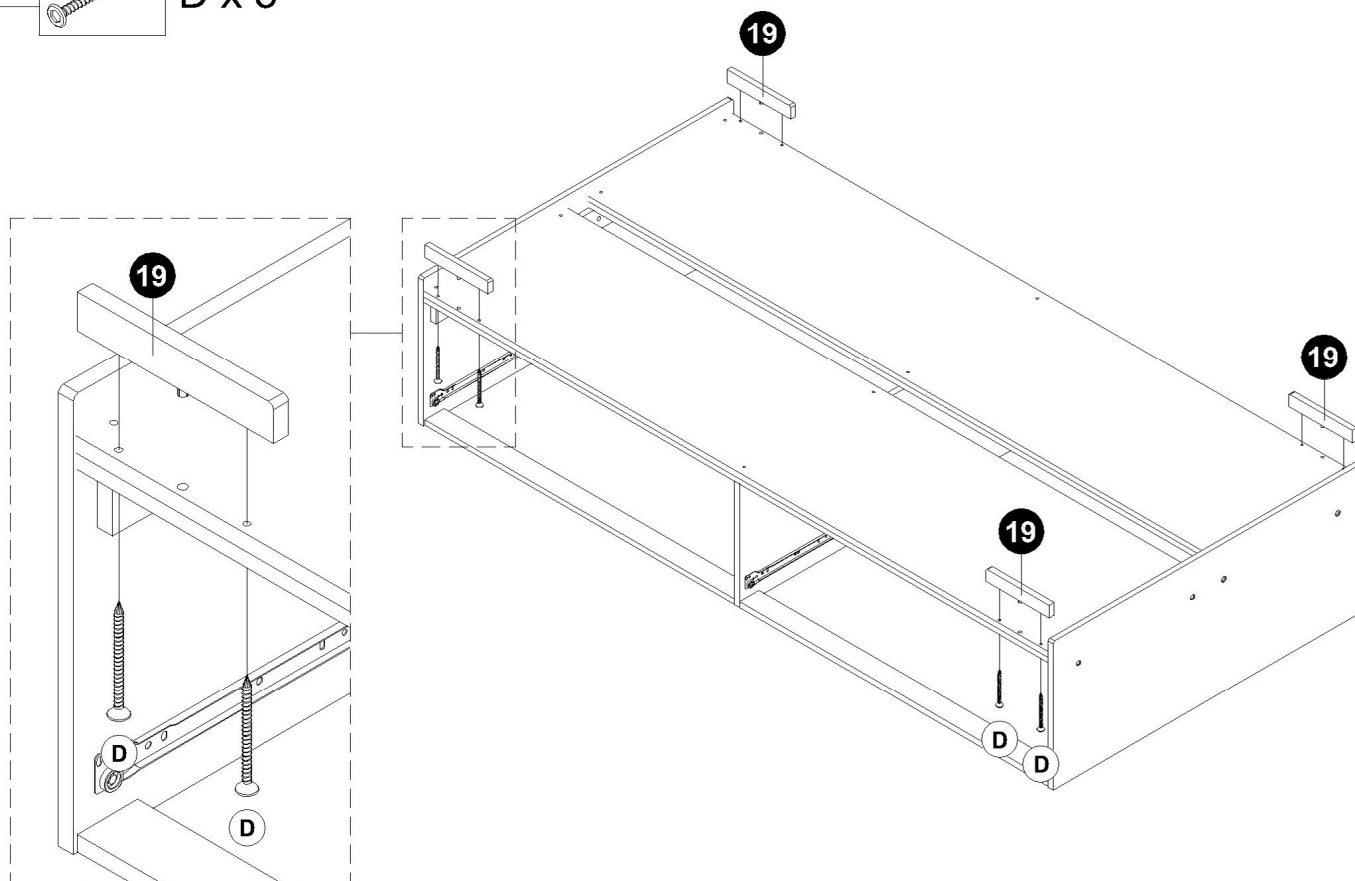

11

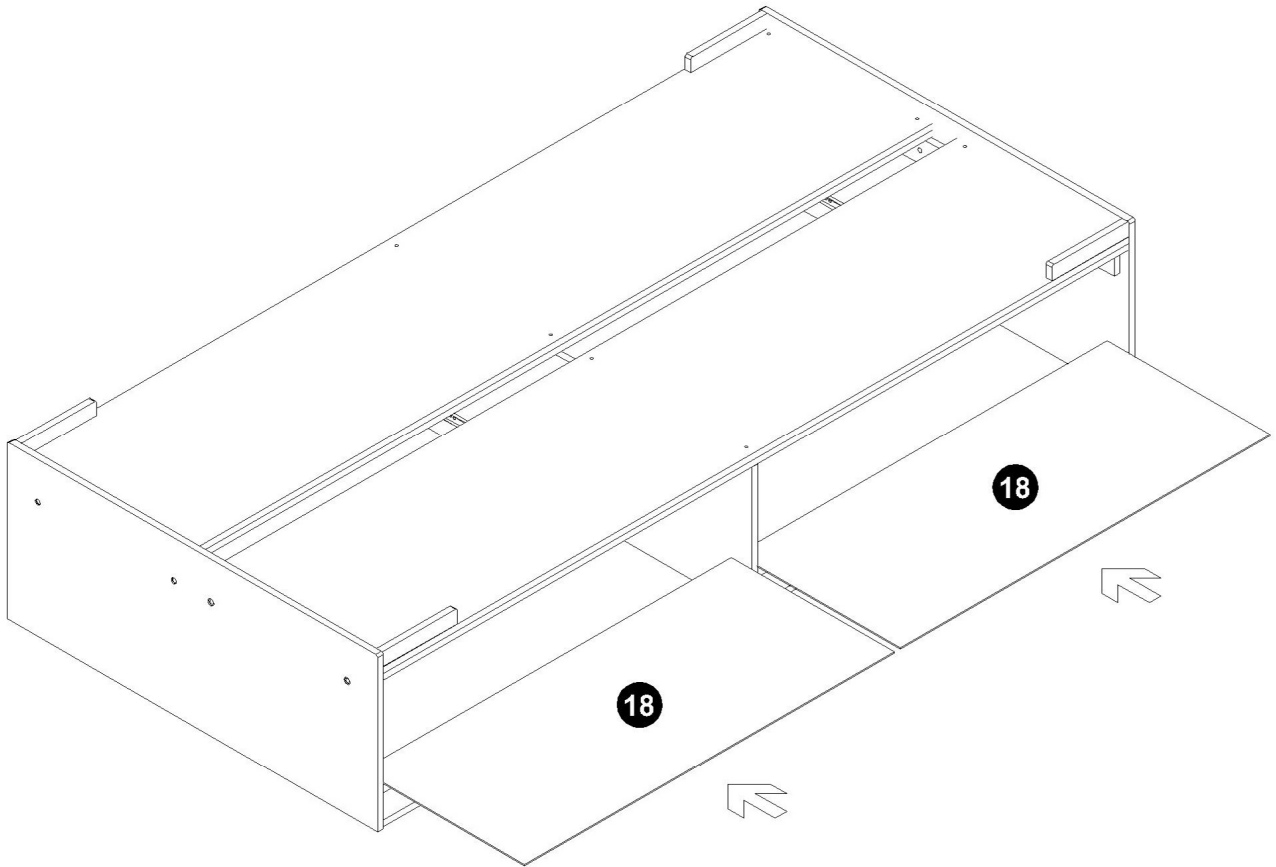

12

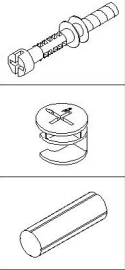

A x 4  
B x 4  
C x 8

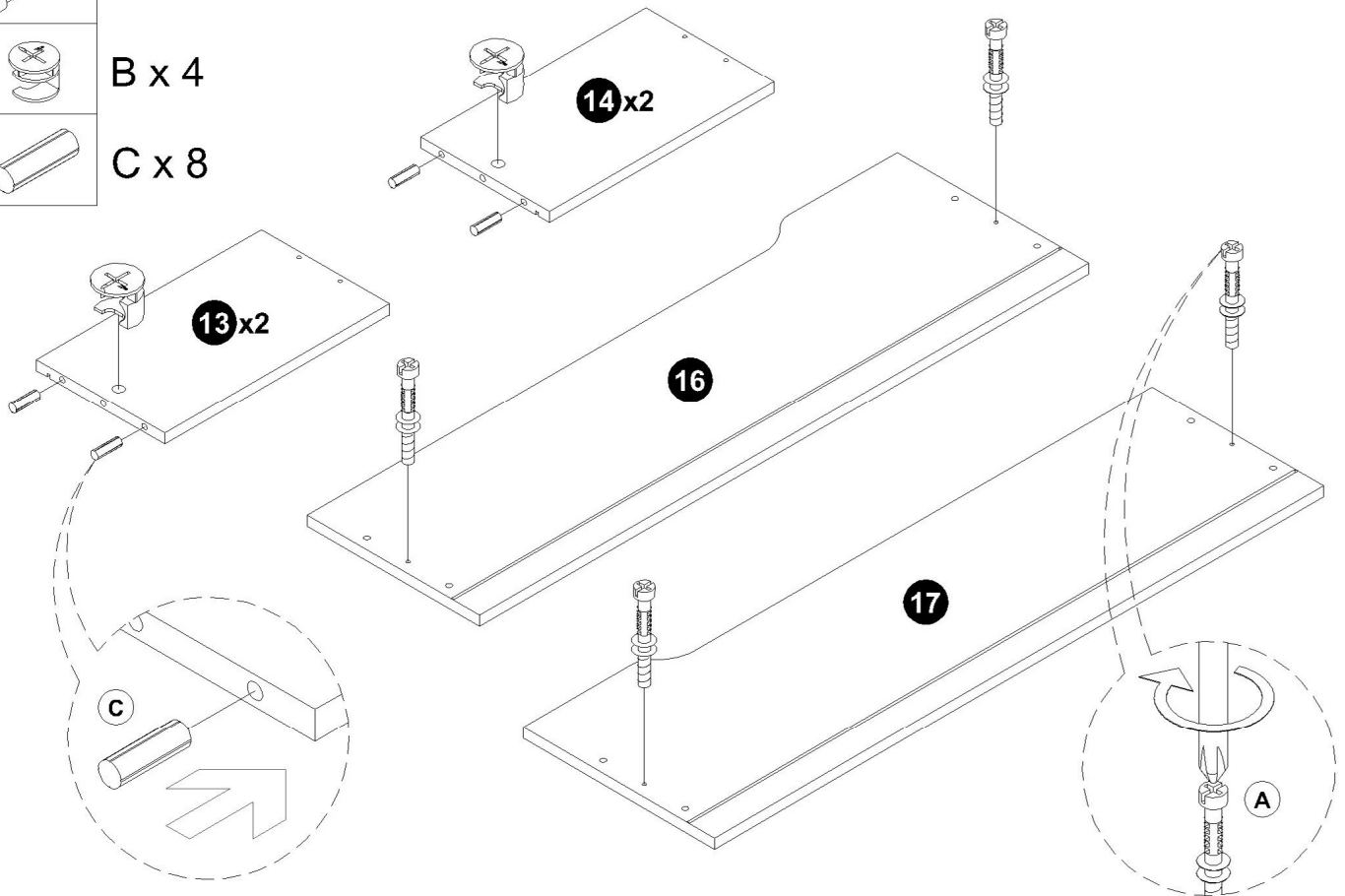



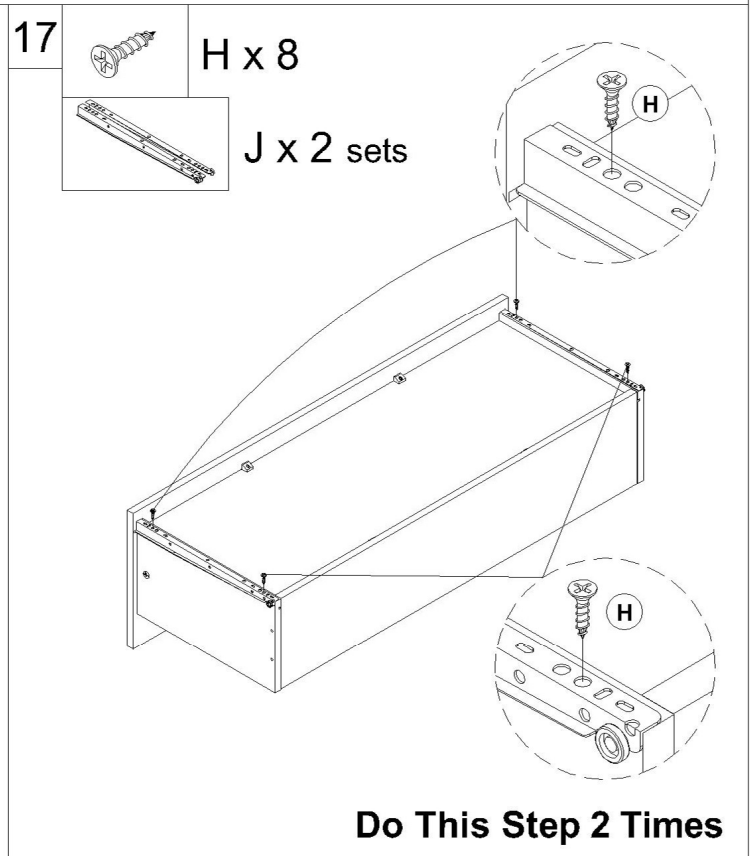
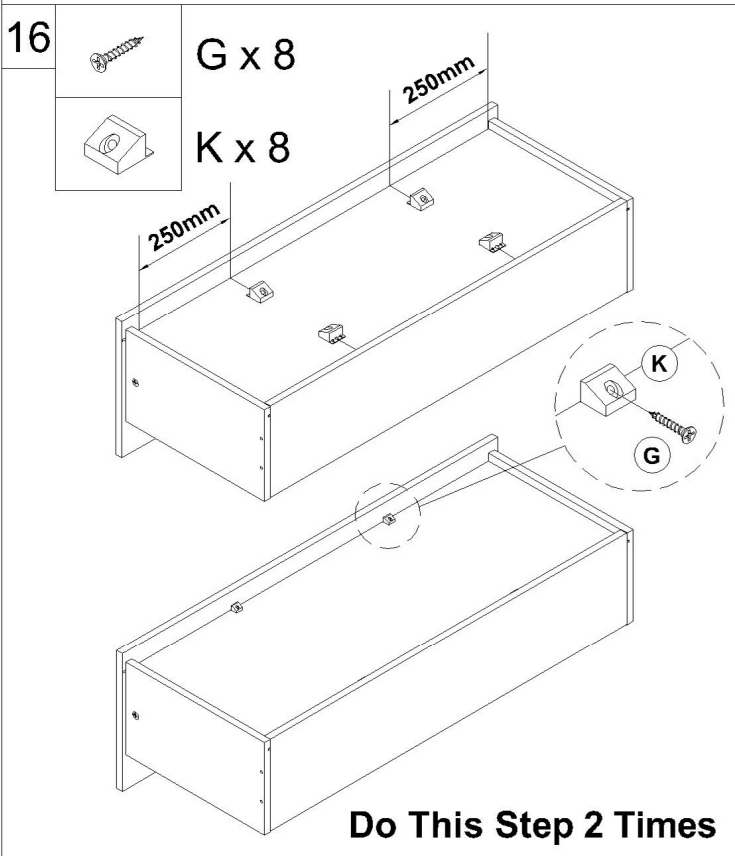
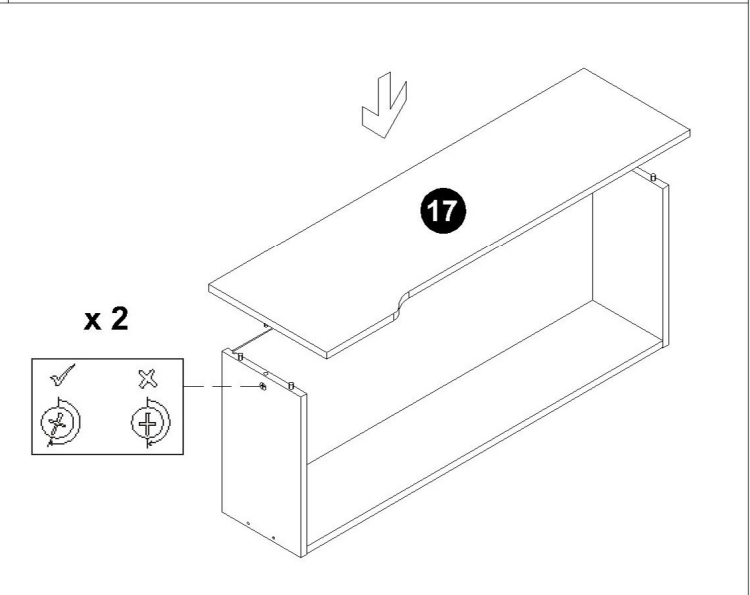
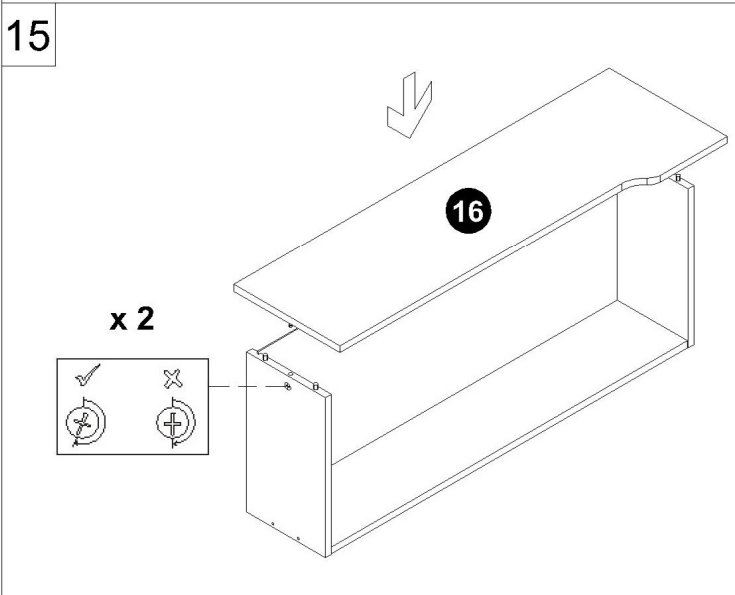
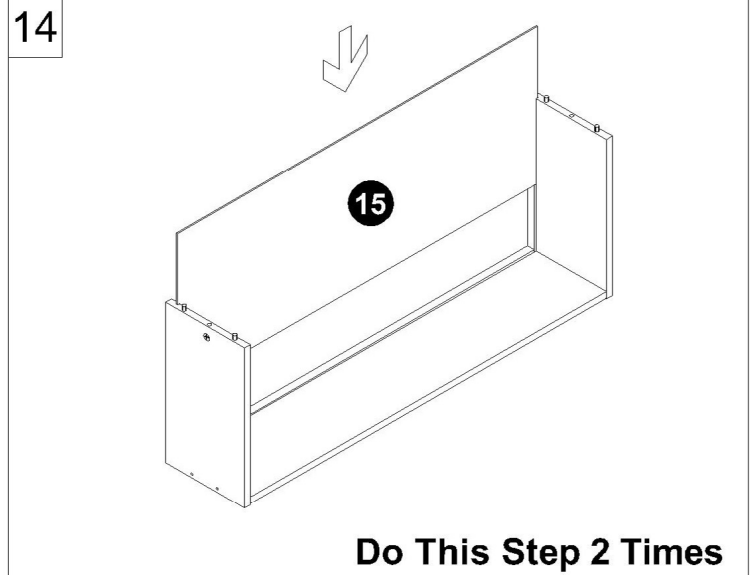
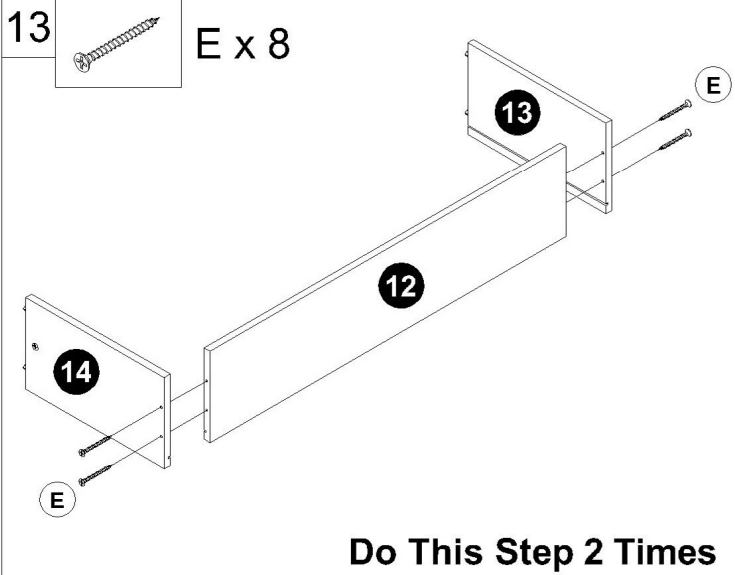

18

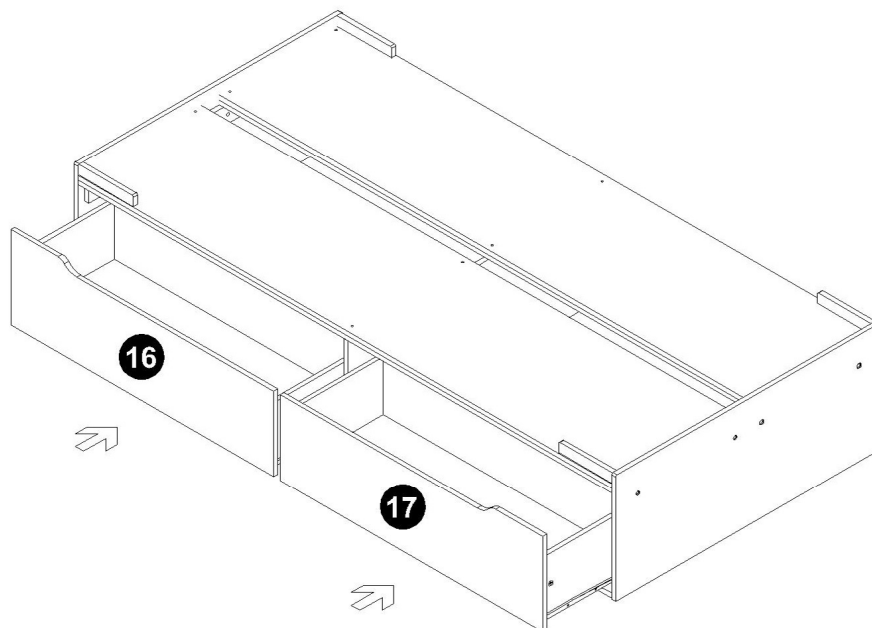

19



P x 4

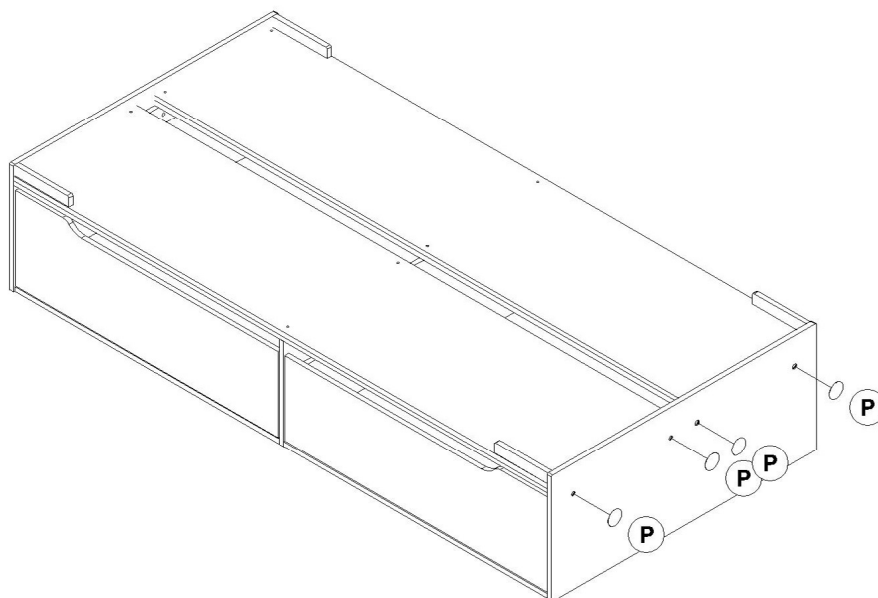

20



P x 4

