

GUILD

16L WET AND DRY VAC

Instruction Manual

GWD16

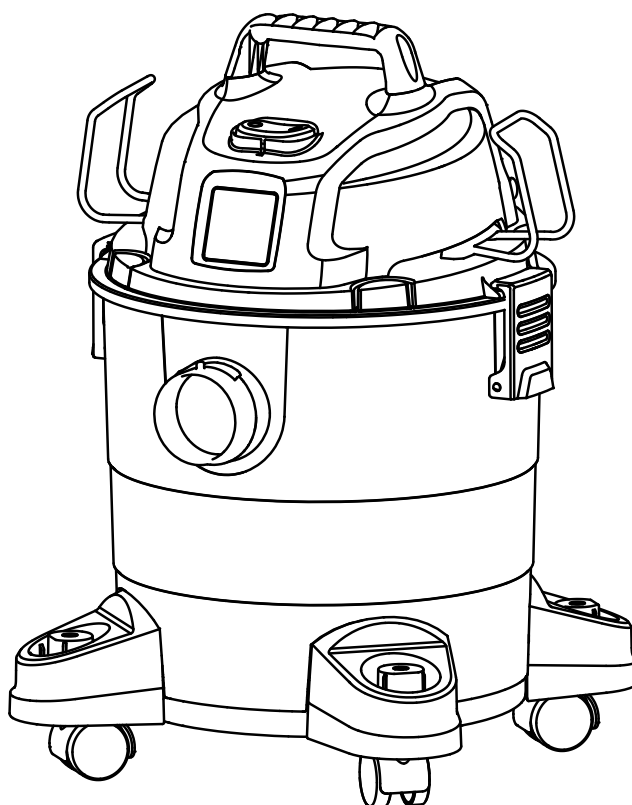

GUILD

After Sales Support

UK/Ireland 03303 800 661

Important- Please read these instructions fully before operating or maintaining your Guild wet/dry vacuum.

These instructions contain important information that will help you get the best from your Guild wet/dry vacuum cleaner, ensuring it remains safe to operate.

If you require any assistance or have damaged or missing parts, please call the After Sales Helpline on 03303 800 661

Table Of Contents

Safety Symbols And Warnings	3
Unpacking & Checking Carton Contents	7
General Assembly	8
General Operation	13
Dry & Wet Vacuum Operation	13
Blower Operation	18
Maintenance	19
Cleaning Reusable Cloth Filter	20
Cleaning Foam Filter	21
Troubleshooting	22
Technical Data	23
Replacement Parts List	24
Guarantee	24
Recycling And Disposal	25

Thank you for purchasing this Guild® wet and dry vacuum cleaner. With Guild® you are obtaining a high-quality product that is engineered for optimal performance. This vacuum cleaner is suitable for use with both liquids and dry materials.

FOR YOUR SAFETY: CAREFULLY READ AND UNDERSTAND ALL INSTRUCTIONS.

Safety Symbols And Warnings

Important- Please read these instructions fully before starting assembly

The following warning symbols appear throughout this manual and indicate the appropriate safety measures you should take when operating and maintaining the appliance. Take extra care, beware of hazards.



Caution



The product complies with the applicable European directives and an evaluation method of conformity for these directives was followed.



The product confirms to relevant UK regulatory requirements.

IPX4 Protection against penetration of dust, protection against vertical water drips.



Protection class II.



Electrical appliances must not be disposed of with the domestic waste.

Safety Symbols And Warnings

Important- Please read these instructions fully before starting assembly

READ AND UNDERSTAND ALL INSTRUCTIONS BEFORE USING THIS VACUUM CLEANER.

Read and understand this instruction manual and all labels on the Wet/Dry Vacuum cleaner before operating. Safety is a combination of common sense, staying alert and knowing how your vacuum cleaner works. Use this Wet/Dry Vacuum only as described in this manual. To reduce the risk of personal injury or damage to your Wet/Dry Vacuum, use only recommended accessories.

SAVE THIS MANUAL FOR FUTURE REFERENCE.

When using an electrical appliance, basic precautions should always be undertaken including the following:

WARNING: TO REDUCE THE RISK OF FIRE, ELECTRIC SHOCK, OR INJURY:

- Never leave the appliance switched on unattended, if you leave the work area, switch the appliance off or unplug it from the power supply.
- Do not vacuum or use this Wet and Dry Vacuum cleaner near flammable liquids, gases or explosive vapours like gasoline or other fuels, lighter fluids, cleaners, oil-based paints, natural gas, hydrogen, or explosive dusts like coal dust, magnesium dust, grain dust or gun power. Sparks inside the motor can ignite flammable vapours or dust.
- This vacuum cleaner is not suitable for the vacuuming of asbestos or asbestos dust.
- Do not vacuum anything that is burning or smoking, such as cigarettes, matches, or hot ashes.
- Keep hands and body parts away from the suction ports on the vacuum cleaner. High powered suction can cause personal injuries.

Safety Symbols And Warnings

Important- Please read these instructions fully before starting assembly

- Ensure the hose and connections are always pointed away from the users face, hair, ears and eyes during operation and never direct the nozzle towards persons or animals.
- Clear the working area of any items or precessions that you do not wish to be vacuumed before operation.
- Keep cord away from heated surfaces.
- Do not expose to rain. Store indoors.
- Do not unplug by pulling on the cord. To unplug, grasp the plug, not the cord.
- Do not use with damaged cord, plug or other parts.
- Do not pull or carry by cord, use cord as handle, close a door on cord, or pull cord around sharp edges or corners.
- Do not run vacuum cleaner over cord.
- Do not handle the plug or vacuum cleaner with wet hands.
- To reduce the risk of health hazards from vapours or dusts, do not vacuum toxic materials.
- Frequently check that the float valve positioned underneath the motor is able to move freely.
- Do not use or store near hazardous materials.
- Do not use this vacuum cleaner with a torn filter or without the filter installed.
- Do not allow to be used as a toy. Close attention is necessary when used by or near children.
- To reduce the risk of injury from accidental starting, unplug power cord before changing or cleaning filter.
- Do not leave vacuum cleaner unattended when plugged in. Unplug from power supply when not in use and before carrying out maintenance.
- Turn off Wet and Dry Vacuum cleaner before unplugging.
- Do not cover the ventilation openings. Do not vacuum with any ventilation openings blocked; keep free of dust, lint, hair or anything that may reduce air flow.



Safety Symbols And Warnings

Important- Please read these instructions fully before starting assembly

- To reduce the risk of falls, use extra care when cleaning on stairs.
- Keep hair, loose clothing, fingers, all parts of body away from openings and moving parts.
- If the supply cord is damaged, it must be replaced by the manufacturer, a qualified service agent or similarly qualified persons in order to avoid a hazard.
- This appliance is not intended for use by persons (including children) with reduced physical, sensory or mental capabilities, or lack of experience and knowledge, unless they have been given supervision or instruction concerning use of the appliance by a person responsible for their safety.
- Children should be supervised to ensure that they do not play with the appliance.
- For additional protection: It is recommended that this vacuum cleaner can be used in conjunction with residual current device (RCD) with a rated residual current of 30mA or less.
- Always unplug the appliance after use and before cleaning or changing the filters or accessories.

When using as blower:

- Direct air discharge only at work area.
- Do not use Wet/Dry Vacuum as a sprayer.
- Do not direct air at bystanders.
- Keep children away when blowing.
- Wear safety goggles.

Unpacking & Checking Carton Contents

Parts

- | | | | |
|---------------------|-----------------------------|--------------------|------------------------------------------|
| 1 Handle | 6 Vacuum Port | 11 Hose | 16 Dust Bag X5 |
| 2 Power Head | 7 Container | 12 Extension Wands | 17 Reusable Cloth Filter (pre-installed) |
| 3 On/Off Switch | 8 Caster | 13 Crevice Tool | 18 Screws |
| 4 Hose Storage Rack | 9 Blowing Port | 14 Floor Nozzle | |
| 5 Latch | 10 Power Cable Storage Hook | 15 Foam Filter | |

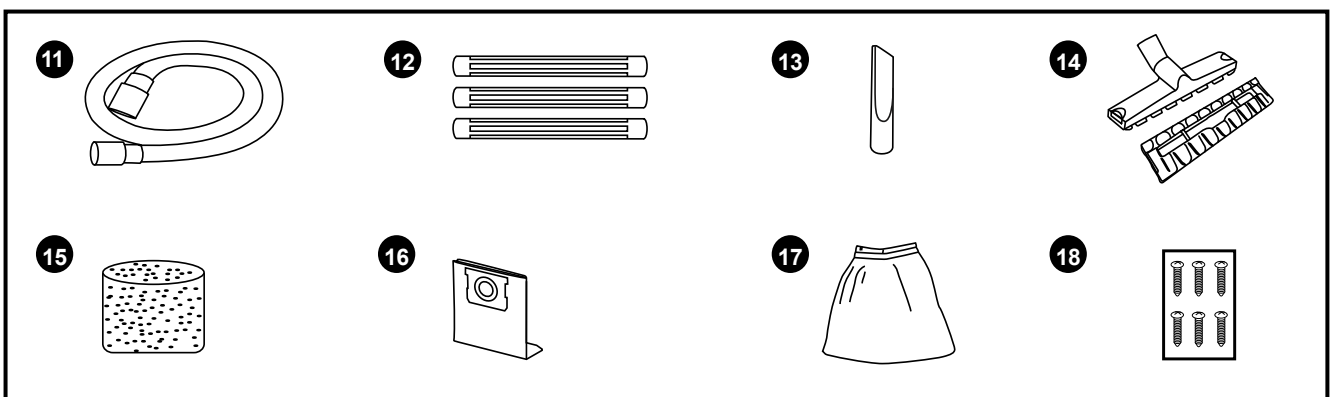
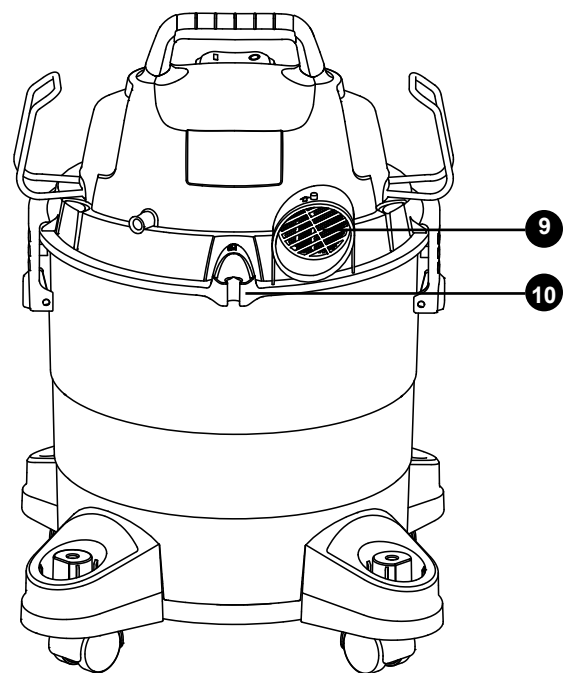
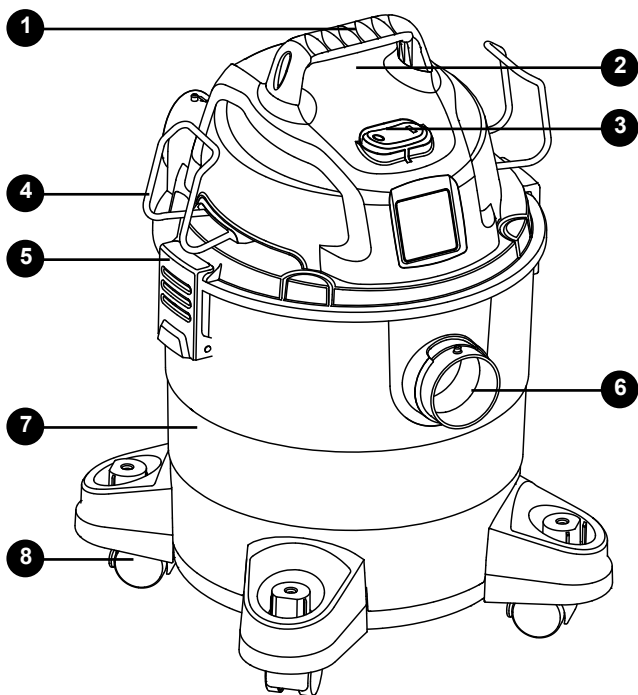

General Assembly

A Phillips head screwdriver is required. 

1. Un-clip the latches (Fig. 1).
2. Lift the power head from the container (Fig. 2). Remove the contents from inside the container (Fig. 3).
3. Make sure you have all the contents that are listed on page 6 .

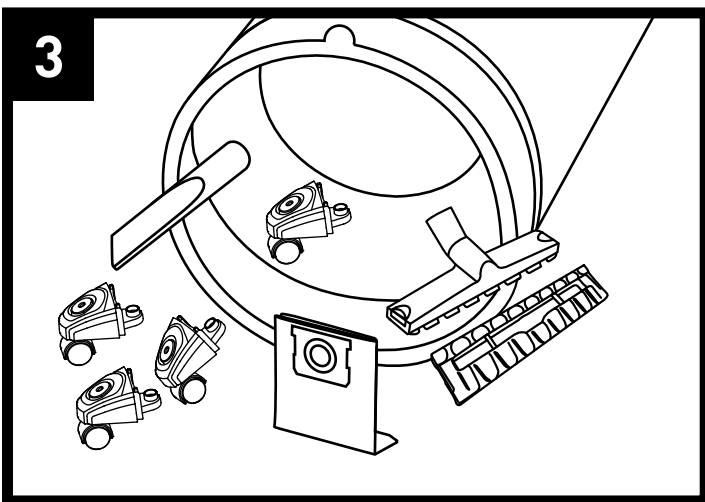
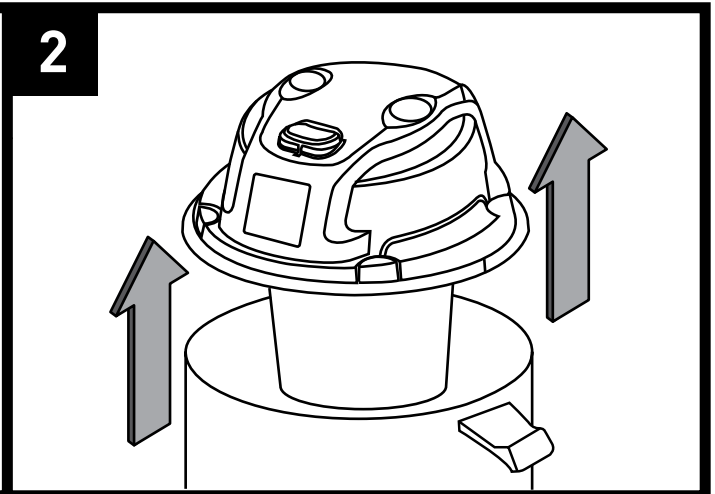
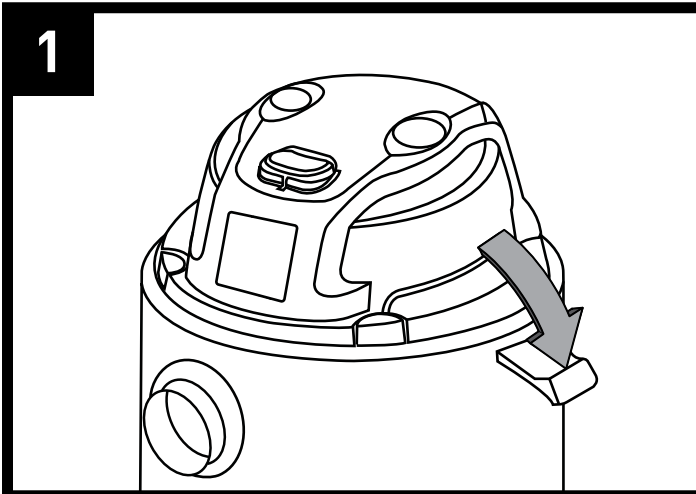

General Assembly

4. Insert the carry handle into the slots located on the top of the power head, and secure with the screws provided. Do not over-tighten the screws (Fig. 4).
5. With the power head removed, turn the container upside down. Insert the feet with casters into the slots and apply pressure until they click into place, and secure them with supplied screw. Do not over-tighten the screws (Fig. 5).
6. Position the hose storage rack as illustrated. Insert one side of the rack into the support hole on the side of the powerhead, making sure it is secured in place. Squeeze in the other end and insert it into the corresponding channel, making sure it is secured (Fig. 6 & 7). Duplicate this process for both hose storage racks on either side of the powerhead.

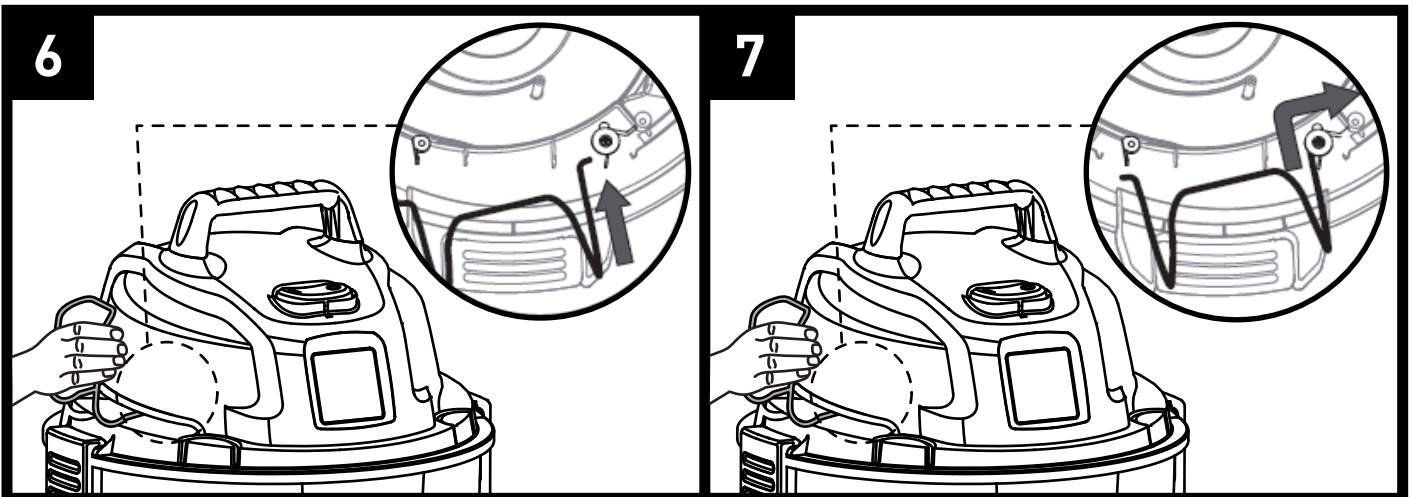
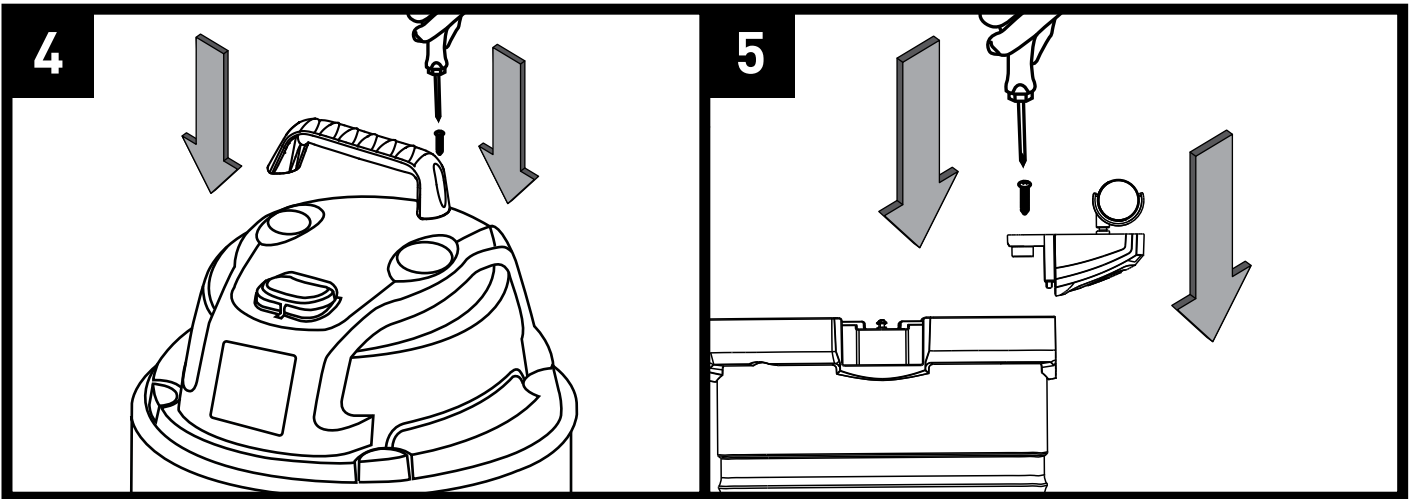

General Assembly

7. Your vacuum cleaner comes ready for dry vacuum cleaning with the cloth filter pre-installed. If the cloth filter is not installed, refer to page 14 for filter installation instructions.
8. Optionally, for improved dust filtration, fully fit the dust bag flange onto the inlet stub, taking care not to damage the bag (Fig. 8).
9. For wet vacuuming, replace the cloth filter with the foam filter supplied. Do not use a dust bag when wet vacuuming. If foam filter is not installed, refer to page 15 for filter installation instructions.
10. Place the power head back on the container, and secure into place using the 2 side latches (Fig.9 & 10).

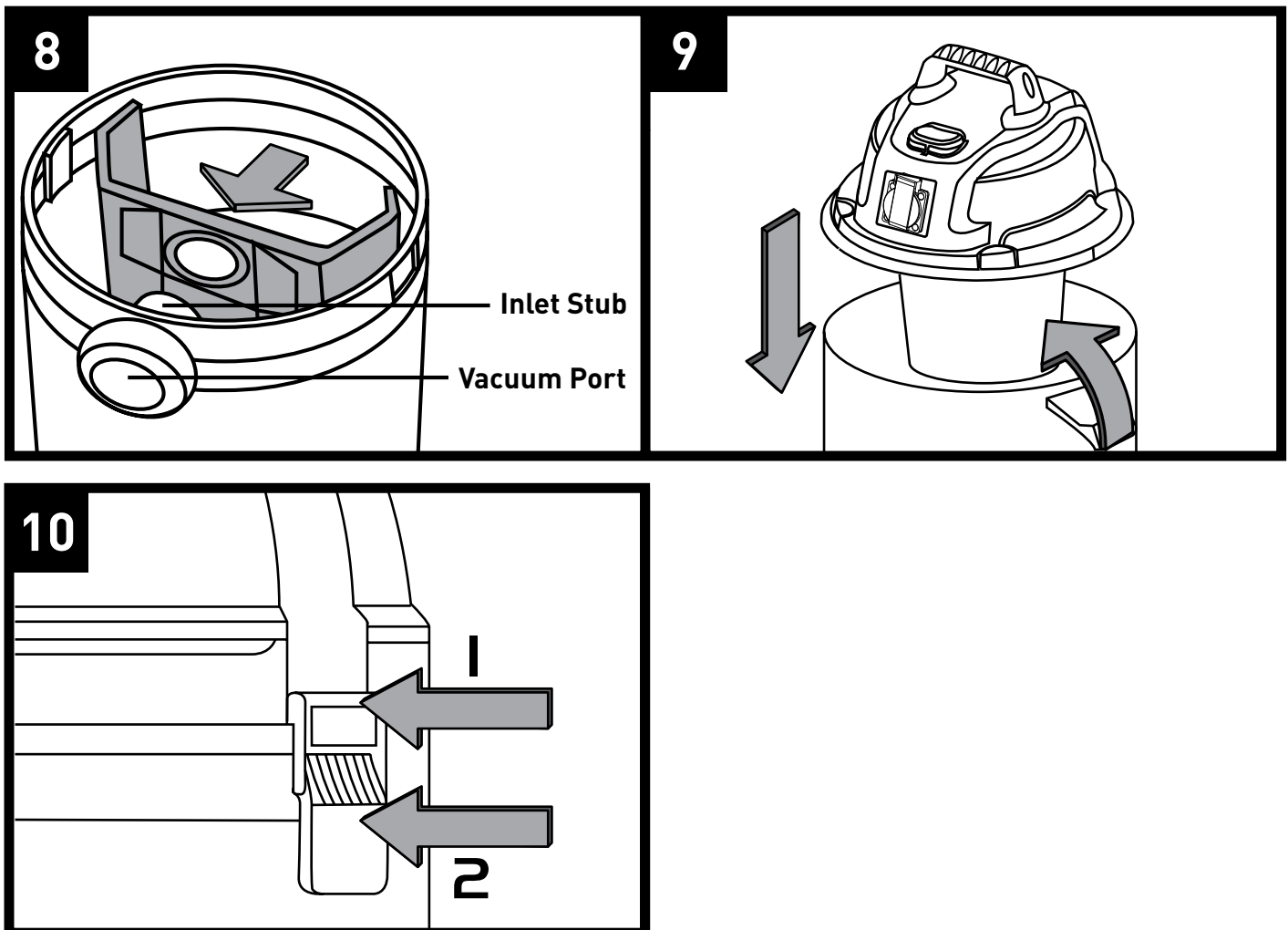

General Assembly

11. Insert the locking end of the hose into the suction port of the container. Rotate clockwise to securely lock into place (Fig. 11).
12. Choose the desired accessories and/or extension wands and push fit onto the hose nozzle (Fig. 12).

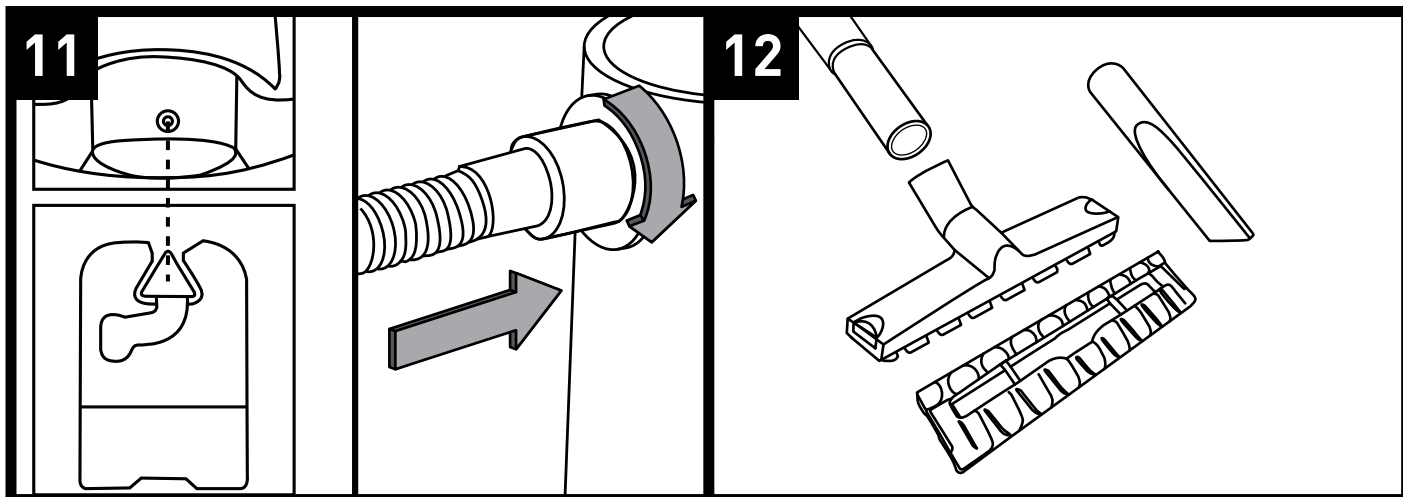

General Assembly

Floor Nozzle Attachments

1. Your wet/dry vacuum cleaner comes complete with two floor nozzle attachments designed for different uses. Ensure you have the correct floor nozzle attachment for maximum efficiency and dust collection.
2. To remove the floor nozzle attachment, release the push clips on either side of the floor tool holder. The attachment should drop out from underneath (Fig. 13).
3. To insert a new floor nozzle attachment, place one side of the attachment into the bottom of the floor tool holder and secure one clip in place. Push the other side up into place and ensure it is securely fitted into the holder (Fig. 14).

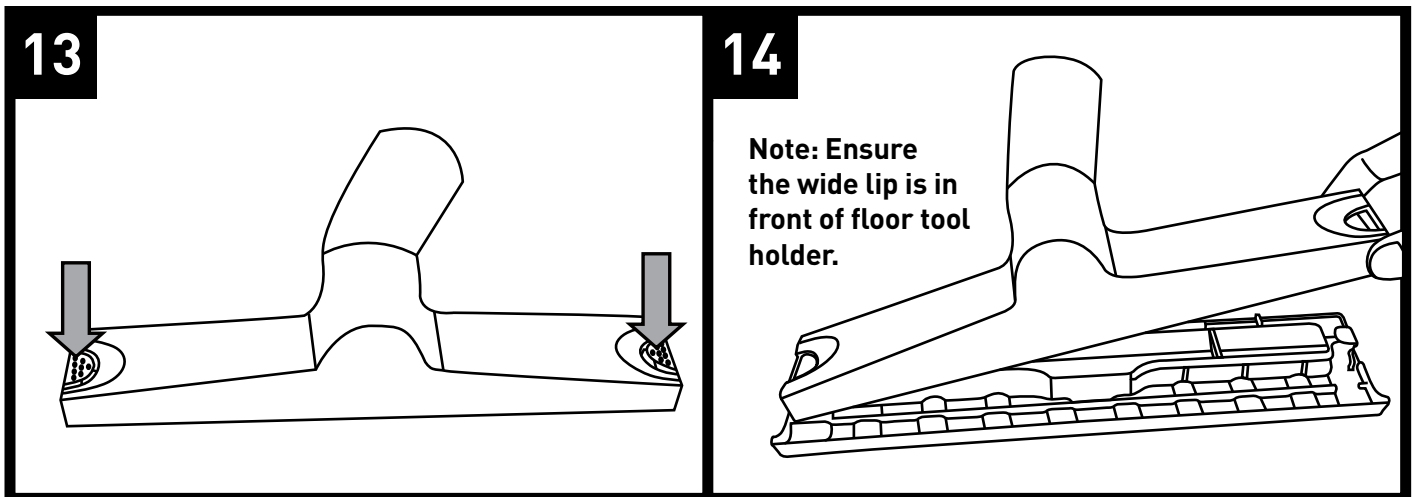

Hard Floor Nozzle:

Attachment is suitable for wet or dry suction on hard floor surfaces. Ensure the squeegee is located towards the back of the floor tool holder and brushes towards the front.

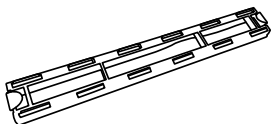

Carpet Floor Nozzle:

Attachment is specifically designed for use on carpeted floor surfaces. Ensure the front lip is facing away from the user and in the direction of vacuuming.

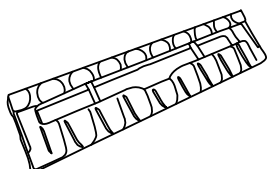

General Operation

DRY & WET VACUUM OPERATION

! **WARNING: ENSURE YOU READ, UNDERSTAND AND APPLY SECTION ENTITLED 'SAFETY INSTRUCTIONS & WARNINGS'.**

! **WARNING: DO NOT VACUUM IN AREAS WITH FLAMMABLE GASES, VAPOURS, OR EXPLOSIVE DUSTS IN THE AIR. DO NOT VACUUM HAZARDOUS SUBSTANCES. FLAMMABLE GASES OR VAPOURS INCLUDE BUT ARE NOT LIMITED TO; LIGHTER FLUID, SOLVENT TYPE CLEANERS, OIL-BASE PAINTS, GASOLINE, ALCOHOL OR AEROSOL SPRAYS. EXPLOSIVE DUSTS INCLUDE BUT ARE NOT LIMITED TO; COAL, MAGNESIUM, GRAIN OR GUN POWDER. TO REDUCE THE RISK OF HEALTH HAZARDS FROM VAPOURS OR DUST, DO NOT VACUUM TOXIC MATERIALS.**

1. Verify that the power cord is disconnected from the power socket (Fig. 1).
2. Choose the desired filter for dry or wet vacuuming following the instructions listed below.
3. After installing the filter, place the power head back on the container securing the latches on either side of the container.
4. Insert the locking end of the hose into the vacuum port and lock in place (Fig. 2).
5. Choose the desired accessories and extension wands and push the attachment(s) onto the hose nozzle (Fig. 3).

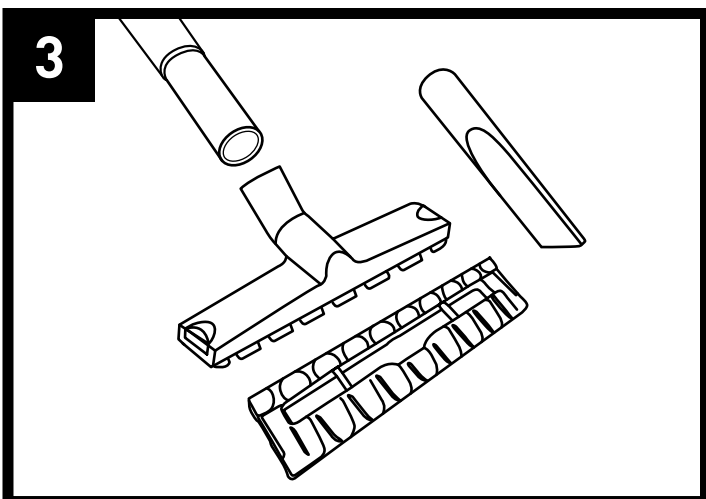
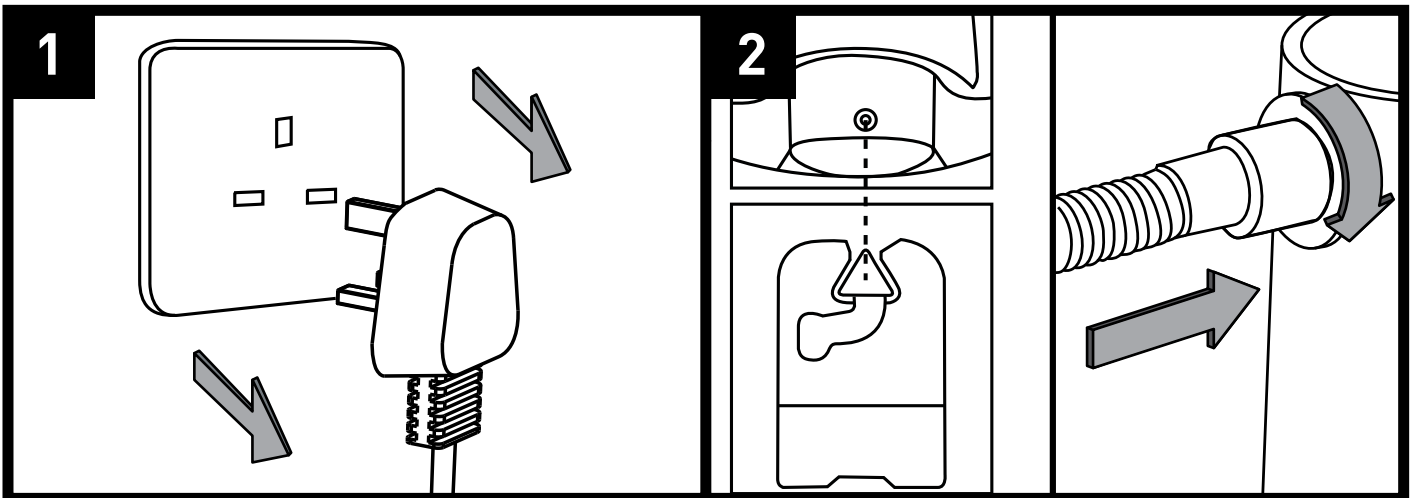

General Operation

6. Plug the power cord into the power socket (Fig. 4).
7. Turn on the motor by assigning the switch to the "I" ON position (Fig. 5).
8. Once you have completed vacuuming, switch to the "O" OFF position and unplug the power cord from the power.

O = OFF

I = ON

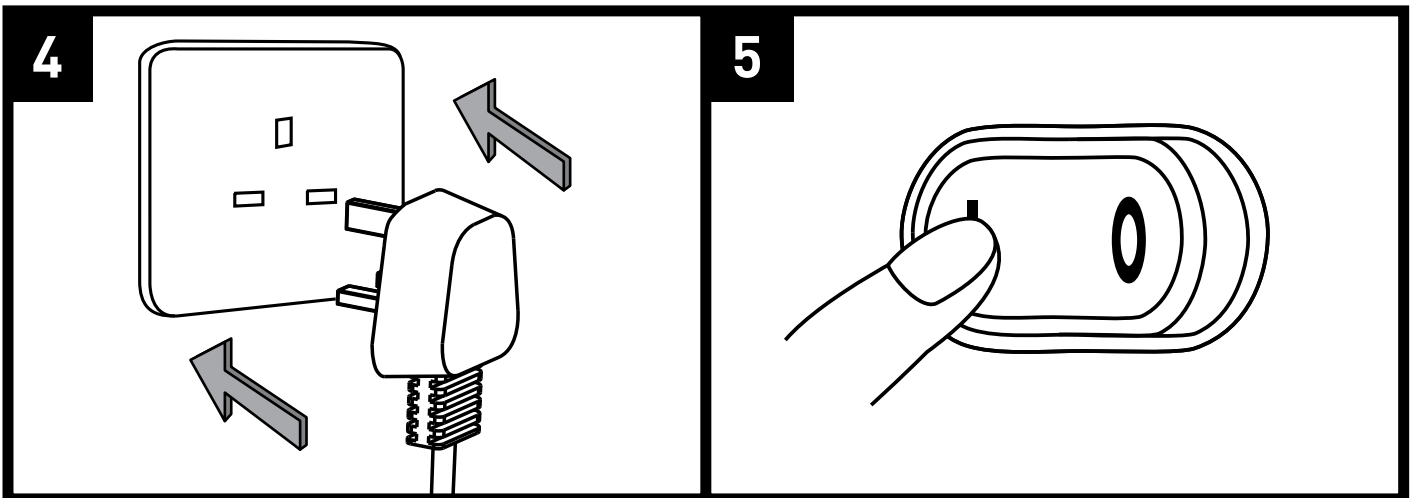

General Operation

FOR DRY VACUUMING:



WARNING: BEFORE INSTALLING, REMOVING OR CLEANING THE VACUUM CLEANER FILTER, ENSURE THAT THE POWER CORD IS REMOVED FROM THE POWER OUTLET AND THE APPLIANCE IS SWITCHED OFF.

1. In order to prepare your vacuum cleaner for dry vacuuming, verify that the cloth filter is securely mounted. If the cloth filter is not installed, follow the instructions listed below.
2. Optionally, for improved dust filtration, fully fit the dust bag flange onto the inlet stub, taking care not to damage the bag. The Vacuum cleaner can be used with or without dust bags.
3. Remove the power head and place in an upside down position.
4. Slide reusable cloth filter down over the filter cage making sure the whole cage is covered. The elasticated opening should form a tight seal around the filter cage. Ensure there is no objects trapped between the filter cage and the cloth filter (Fig. 6 & 7).
5. Replace the power head on to the container.

IMPORTANT: Check the filter regularly for optimal performance. An old or blocked filter will reduce suction performance

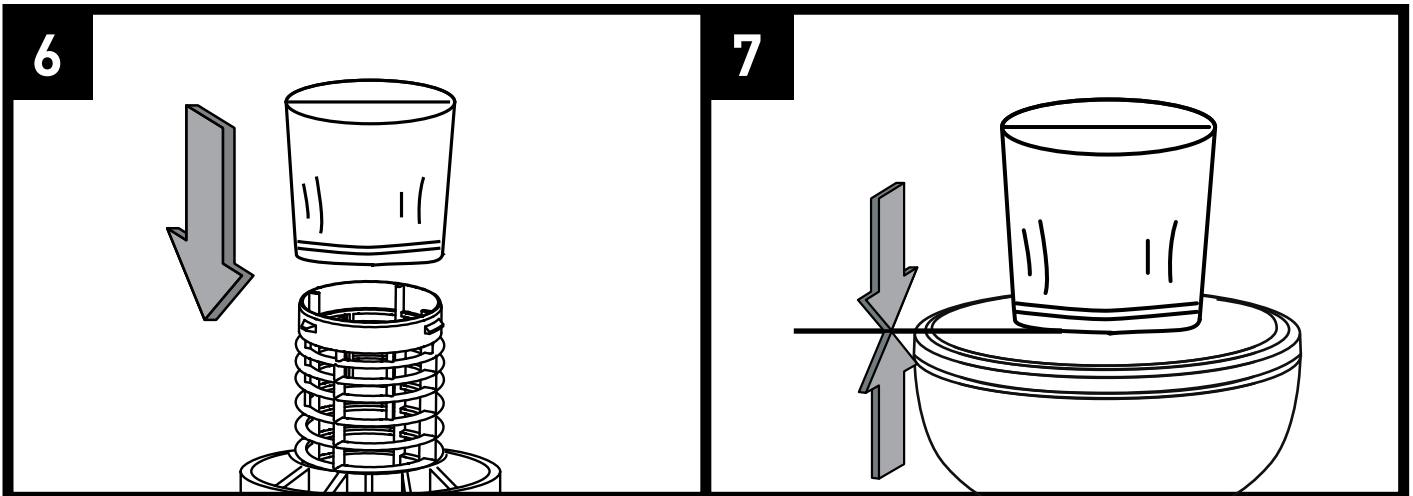

General Operation

FOR WET VACUUMING:

! **WARNING: BEFORE INSTALLING, REMOVING OR CLEANING THE VACUUM CLEANER FILTER, ENSURE THAT THE POWER CORD IS REMOVED FROM THE POWER OUTLET AND THE APPLIANCE IS SWITCHED OFF.**

1. In order to prepare your vacuum cleaner for wet vacuuming, remove the power head from the container and place in the upside down position (Fig. 8).
2. Remove the dry use cloth filter.
3. Carefully install the supplied foam filter over the internal filter cage and place the power head back on the container securing the latches on either side of the container (Fig. 9 & 10).

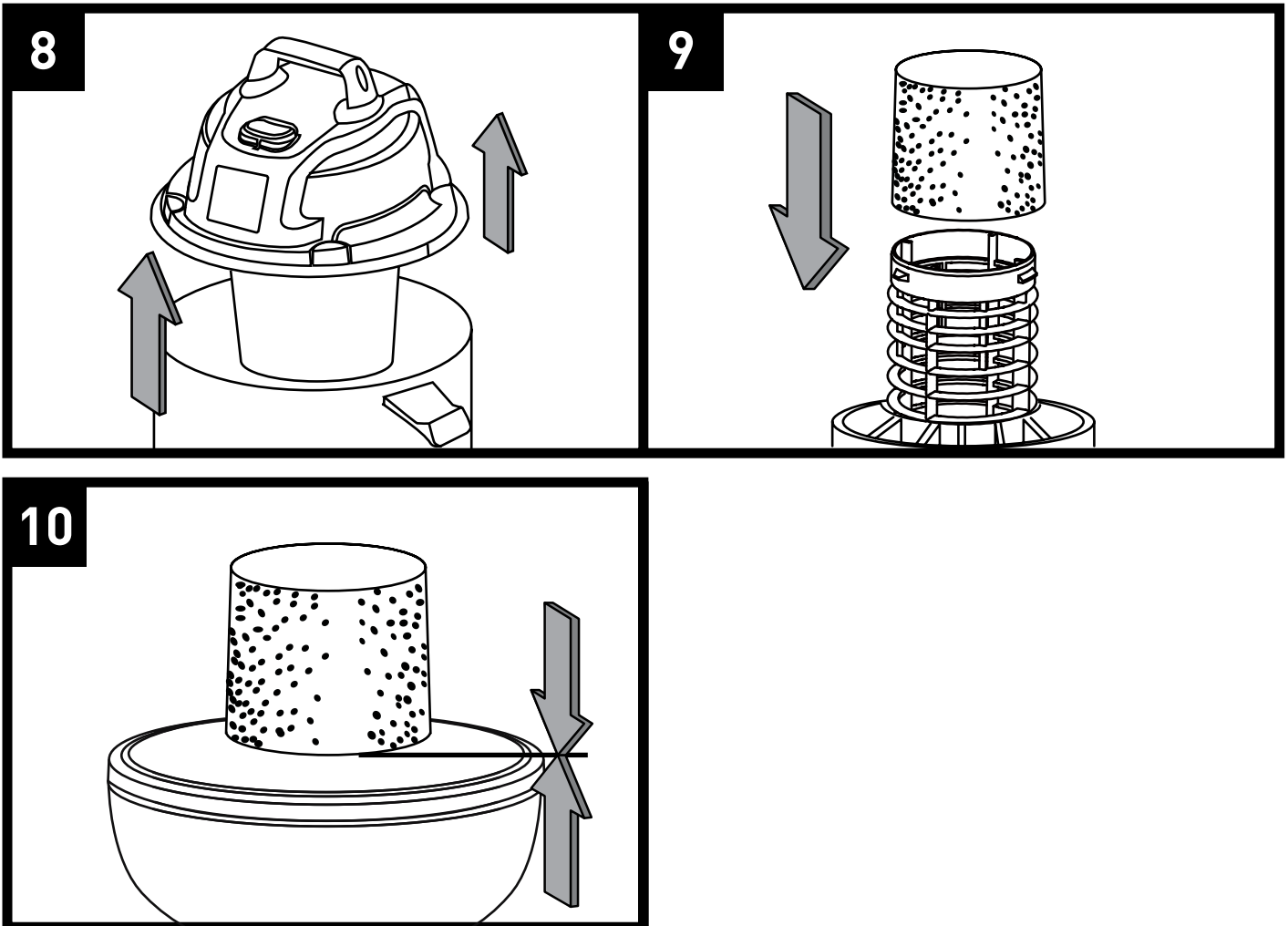

General Operation



WARNING:

DO NOT USE THE CLOTH FILTER FOR WET VACUUMING

DO NOT USE A DUST COLLECTION BAG FOR WET VACUUMING

IMPORTANT! When vacuuming large quantities of liquids, do not immerse the nozzle completely in the liquid; leave a gap at the tip of the nozzle opening to allow air inflow. The machine is fitted with a float valve that stops the suction action when the container reaches its maximum capacity. You will notice an increase in motor noise. When this happens, turn off the machine, disconnect from power supply, and drain the liquid into a suitable receptacle or drain. After wet vacuuming, turn off the machine and remove the plug from the power supply. Empty the container, clean and dry inside and outside before storage.

REMEMBER! The foam filter must be removed after wet vacuuming and the reusable cartridge filter must be reinstalled before dry vacuuming again.

General Operation

BLOWER OPERATION

This wet and dry vacuum cleaner has blow capabilities.

To use the blower feature follow the instructions listed.

 **WARNING: KEEP BYSTANDERS CLEAR FROM BLOWING DEBRIS.**

 **WARNING: WEAR A DUST MASK IF BLOWING CREATES DUST THAT MIGHT BE INHALED.**

1. Verify that the power cord is disconnected from the power socket.
2. Make sure the container and any collected waste is emptied before using as a blower. This also includes removal of the dust bag.
3. Remove hose from the vacuum port.
4. Insert the locking end of the hose into the blowing port on the rear side of the power head and lock into position (Fig. 11).
5. Fit the desired extension wand or nozzle to the vacuum cleaner hose (Fig. 12).
6. Ensure the power switch is turned off and plug into the power supply.
7. Before turning on the wet and dry vacuum cleaner, firmly hold the loose end of the hose. Turn on the motor by turning the switch to the 'I' ON position.

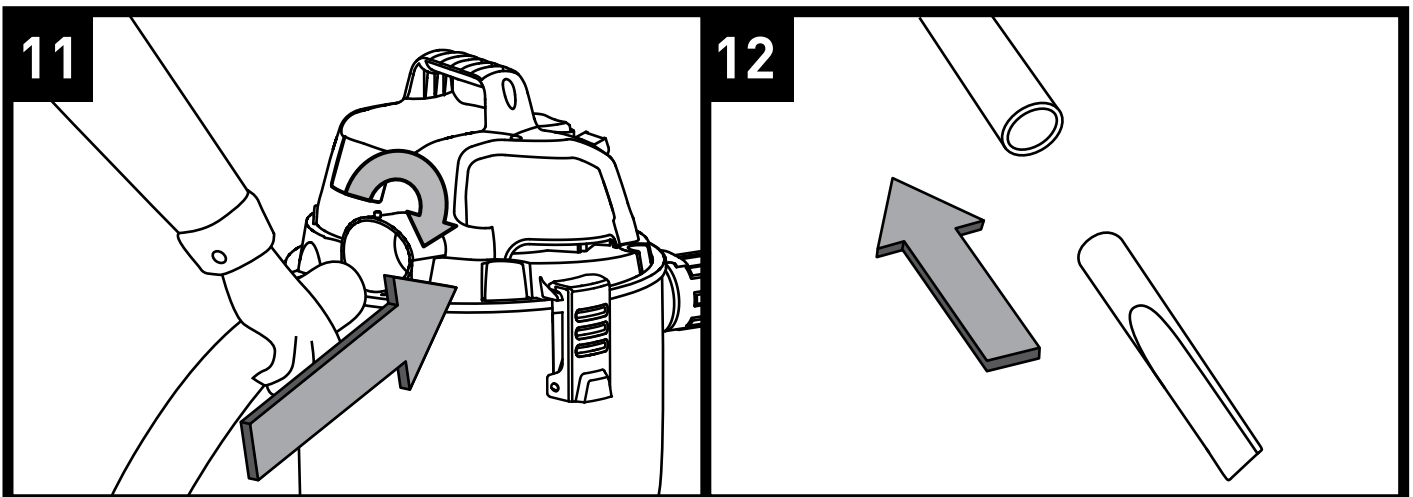

Maintenance

! WARNING: REMOVE THE POWERCORD FROM THE POWER SUPPLY BEFORE CARRYING OUT ANY MAINTENANCE.

1. Verify that the power cord is disconnected from the power socket (Fig. 1).
2. Disconnect the hose from the vacuum cleaner, turning counter clockwise in direction (Fig. 2).
3. Un-clip the latches and remove the power head from the container.
4. Clear all dirt and debris from the container and hose (Fig. 3).
5. Check the hose, attachments, and power cord to verify that they have not been damaged or any debris is trapped and blocking airflow.

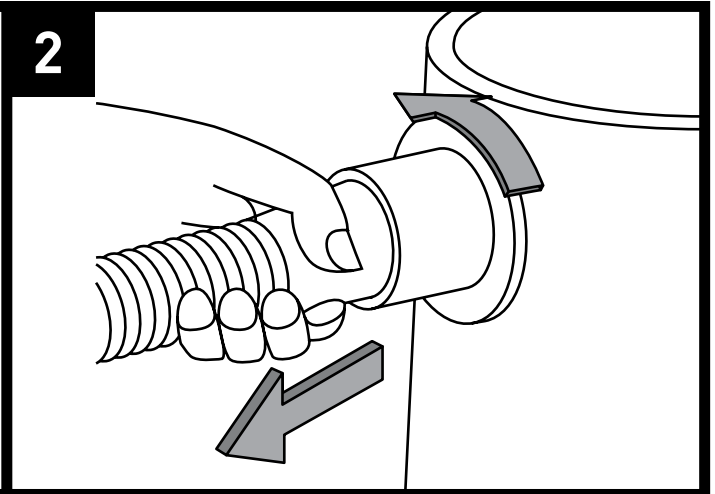
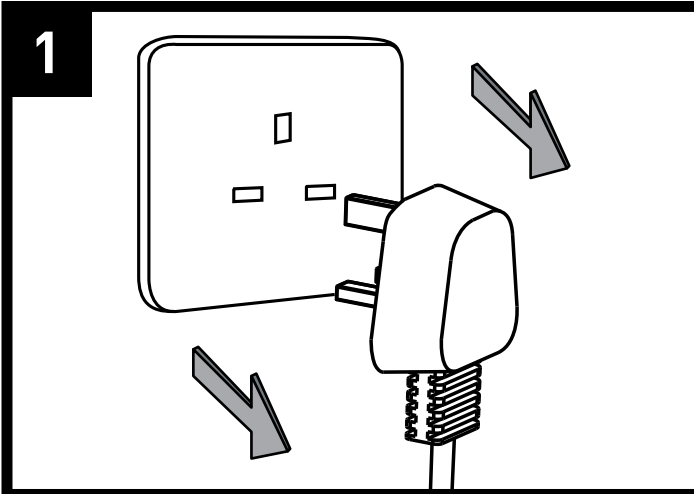

Maintenance

CLEANING REUSABLE CLOTH FILTER

1. With the removed power head in the upside down position, carefully remove the reusable cloth filter from the filter cage. Clean the cloth filter by gently tapping or brushing dirt off. Cleaning should not be done indoors or in living areas. For optimal performance a new filter is recommended (Fig. 4).
2. Use a mild soap and water solution to wash reusable cloth filter and rinse with clean water (Fig. 5).
3. Install cleaned or new filter into place as instructed above on page 14.
4. Wet filters should be removed and allowed to air dry before installing onto the filter cage.

Replacement filters and dust bags can be purchased from the after sales helpline.

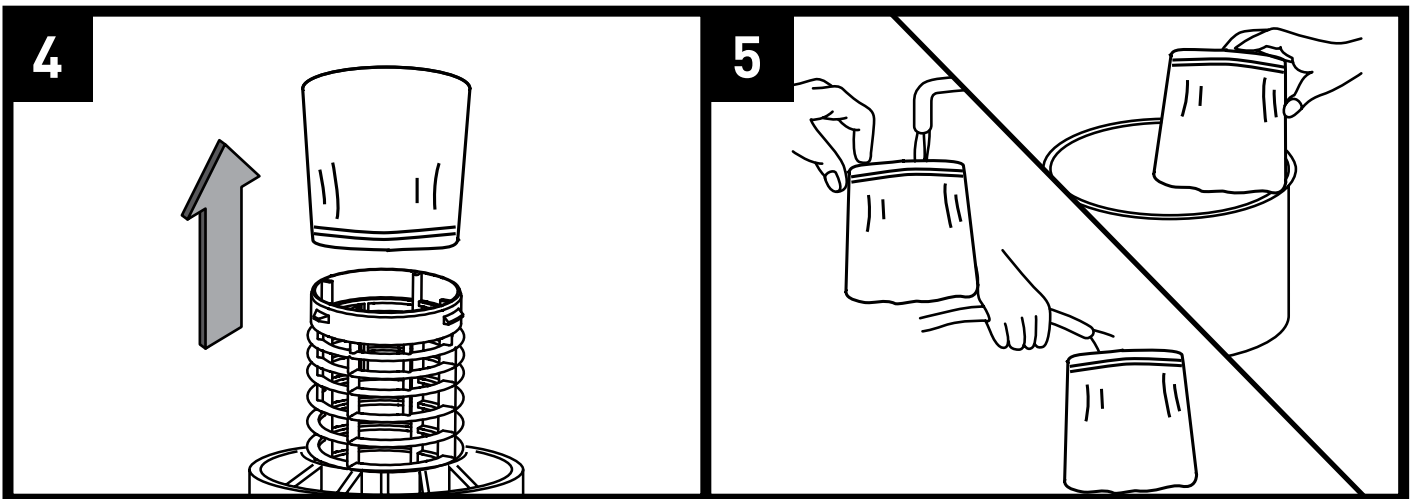

Maintenance

CLEANING FOAM WET FILTER

1. With the removed power head in an upside down position, carefully remove the foam filter by pulling up and over the internal filter cage (Fig. 6).
2. Use a mild soap and water solution to wash foam filter and rinse with clean water (Fig. 7).
3. Allow filter to air dry before installing and using again.
4. Install cleaned or new filter into place as instructed above on page 15.

Replacement filters and dust bags can be purchased from the after sales helpline.

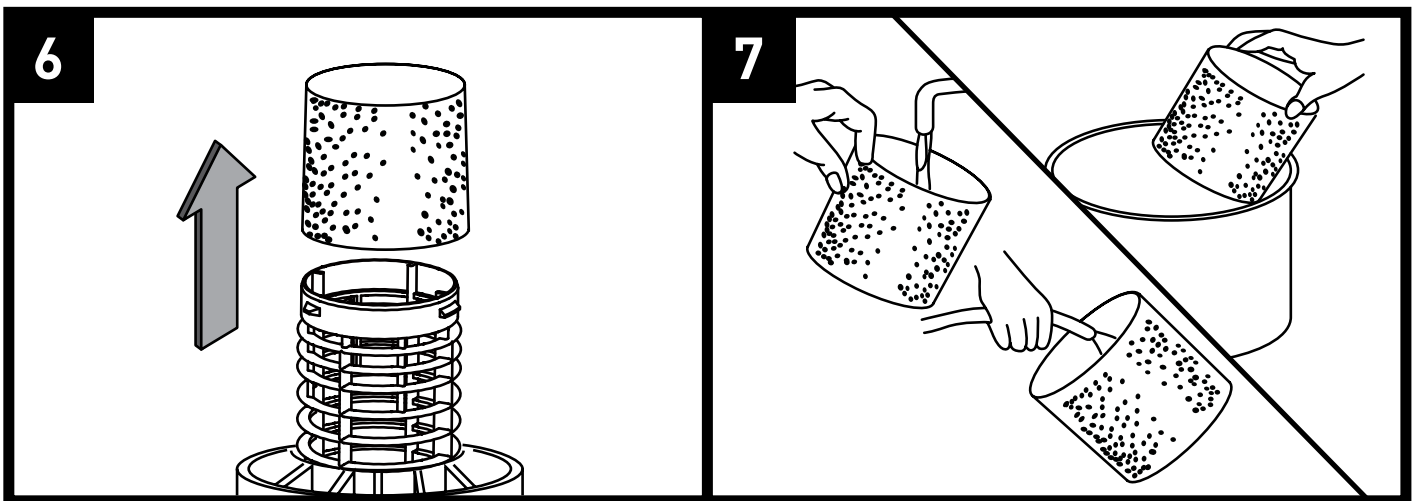

Troubleshooting



WARNING: ONLY PERFORM THE STEPS DESCRIBED WITHIN THESE INSTRUCTIONS! ALL FURTHER INSPECTION, MAINTENANCE AND REPAIR WORK MUST BE PERFORMED BY A QUALIFIED SPECIALIST.



WARNING: TO REDUCE THE RISK OF ELECTRIC SHOCK-UNPLUG BEFORE TROUBLESHOOTING.

CLEANING PERFORMANCE

All vacuum cleaners are very simple and reliable machines, a motor with a fan attached to move air through the machine.

Guild vacuum cleaners are robust and tested for endurance. If your motor is operating, then the most likely cause for a loss in suction is a blockage or an opening somewhere in the appliance.

For a vacuum cleaner to do its job correctly, it needs a working filter (in good condition) in position to help capture dust particles. The optional dust bags help to increase the level of filtration and dust collection. As filters and dust bags become blocked over time, you should expect a drop in performance. This is normal and a good result, it shows that the vacuum cleaner is effectively pulling up and trapping the dust. In short, it's doing what it's supposed to.

To maintain a high cleaning performance from your machine, it is important to replace or clean cartridge filters as necessary. This can be done with a soft paint brush, being careful not to damage the cartridge filter. If you also use dust bags, you will need to replace these when the bag is full or the performance drops.

A performance drop with clean filters can only be caused by a blockage in the tools or the hose. Check all accessories for blockages, and ensure the joints between the vacuum and the end of the nozzle are fitted correctly.

Troubleshooting

PROBLEM	POSSIBLE CAUSE	SOLUTION
The appliance does not work.	No power.	Check the power supply and fuse.
	Functional fault in the power cord, switch, or motor.	Have the damaged part checked by qualified personnel or contact the after sales helpline.
Dust is escaping from the motor cover.	The reusable cloth filter is missing or damaged.	Put in a cloth filter or replace it.
	Misuse the foam filter when dry vacuuming.	Replace the foam filter with the cloth filter.
Low suction power and high operating noise / vibrations.	Dust bag is full.	Replace the dust bag.
	Suction nozzle, hose, or tank inlet is blocked.	Check the suction nozzle, hose, and tank inlet for obstructions.
	Cloth filter is blocked.	Remove the cloth filter and clean.
	Float valve has closed.	Empty the container of any liquid waste and ensure the float valve located underneath the filter is able to move freely.

Technical Data

Model Number	GWD16
Motor	220-240V~50Hz
Power input	1300W
Tank volume	16L
Filter - Dry	Reusable cloth filter, Dust bag (optional)
Filter - Wet	Foam filter
Net weight	3.87kg

Replacement Parts List

Replacement filters and dust bags are available by searching the internet or calling the Guild Aftersales helpline on 03303 800 661.

Parts List	Accessories
551046122	Hose
551051116	Crevice Tool
551023136	Floor Nozzle
551382105	Carpet Nozzle
951445	Extension Wands
950135	Reusable Cloth Filter
951319X2	Dust Bag
950086	Foam Filter

Guarantee

This product is selected for DOMESTIC USE ONLY and not for business use. This product is guaranteed against manufacturing defects for a period of 24 months. This does not cover the product where the fault is due to misuse, abuse, use in contravention of the instructions, or where the product has been the subject of unauthorised modifications or alterations, or has been the subject of commercial use. In the event of a problem with the product within the guarantee period please contact the after sales helpline. Your statutory rights remain unaffected.

Recycling And Disposal

Recycle unwanted materials instead of disposing of them as waste. All tools, hoses and packaging should be sorted, taken to the local recycling centre and disposed of in an environmentally safe way.

Recycle rather than dispose of unwanted material in landfill whenever possible. The machine must be delivered in rigid packaging to avoid damage during transportation. The packaging and the machine itself are manufactured from recyclable materials and should be disposed of accordingly.

Only dispose of electrical/battery terms in separate collection schemes, which cater for the recovery and recycling of materials contained within. Your cooperation is vital to ensure the success of these schemes and for the protection of the environment.



This marking indicates that this product should not be disposed with other household wastes throughout the EU. To prevent possible harm to the environment or human health from uncontrolled waste disposal, recycle it responsibly to promote the sustainable reuse of material resources.

Produced in China for Argos Limited, London, EC1N 2HT, UK.
Argos (N.I.) Ltd, Forestside Shopping Centre, Upper Galwally, Belfast, BT8 6FX, UK.