

**Service • Assistenza • Dienstverlening • Serwis
Servis • Szerviz • Сервисная служба**

4424912COMQEUK

Name • Nom • Nome • Naam • Nazwa • Imięno • Názov • Név • Denumire • Istin • Haavahie	Tamlin
Nr. • No. • N° • Homep • Č • Sz	
Typ • Type • Tip • Tipos • Tipo • Tm	
	
	
	

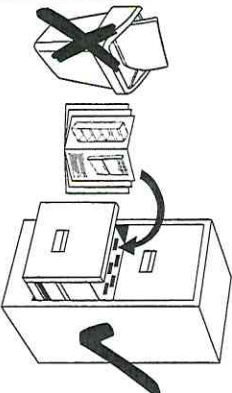
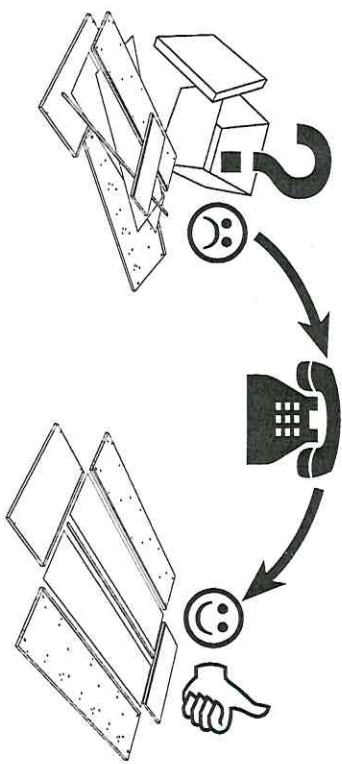
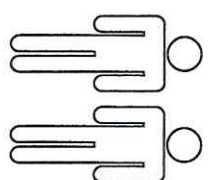
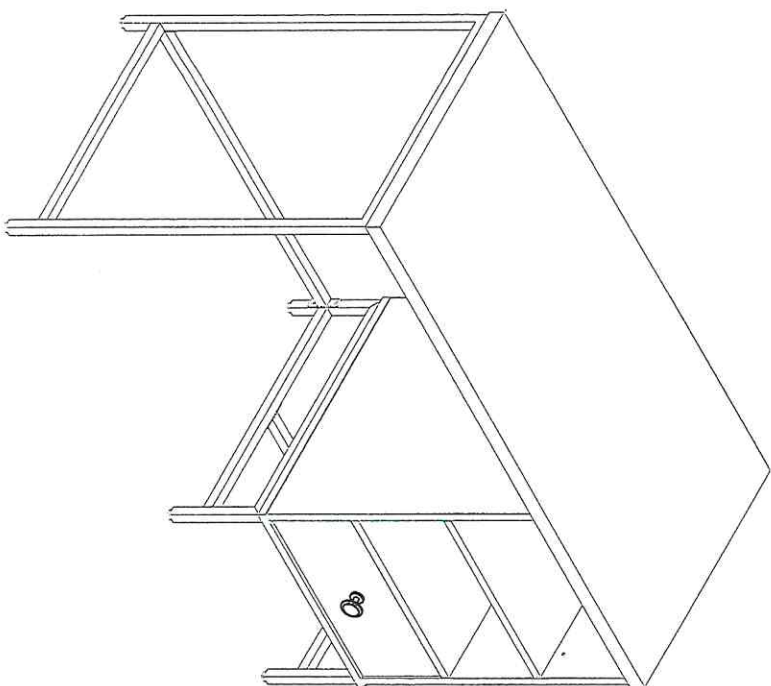

- D** Montageanleitung
- FR** Notice de montage
- NL** Handleiding voor de montage
- CZ** Montážní návod
- HU** Szerelési útmutató
- TR** Montaj talimatı
- GB** Assembly instructions
- IT** Istruzioni di montaggio
- PL** Instrukcja montażu
- SK** Návod na montáž
- RO** Instrucțiuni de montaj
- RU** Инструкция по монтажу

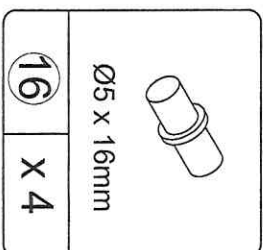
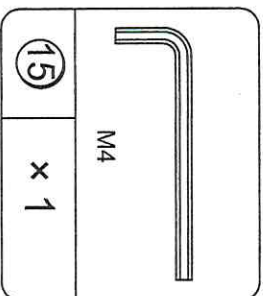
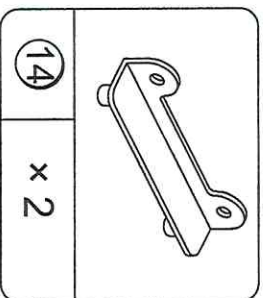
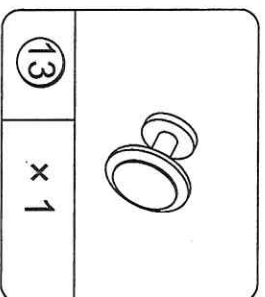
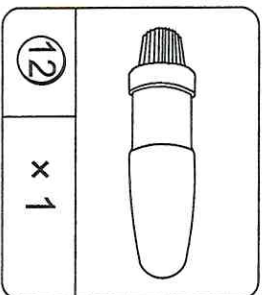
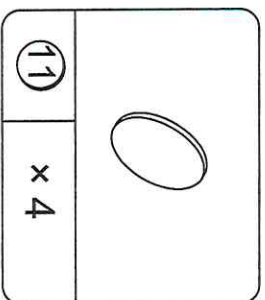
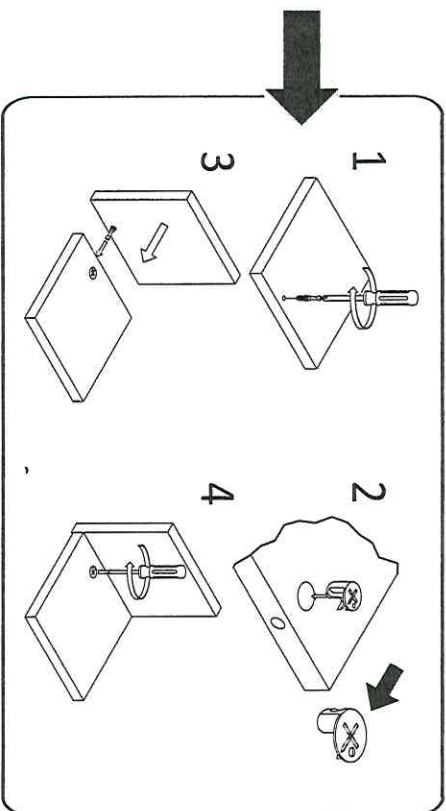
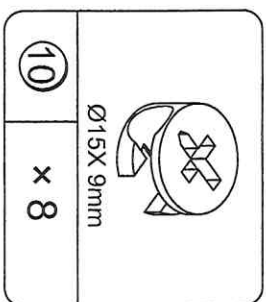



ⓐ

T4424912100KX



ⓑ

T4424912110KX

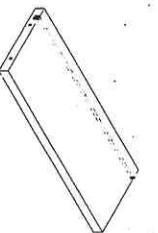

ⓒ

T4424912120KX

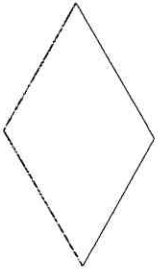

ⓓ

T4424912130KX

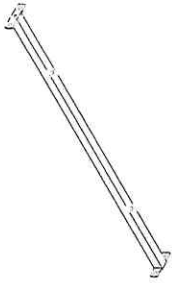

ⓔ

T4424912140KX

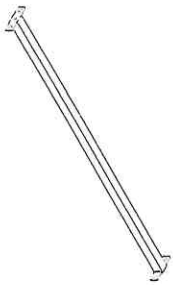

ⓕ

T4424912150KX

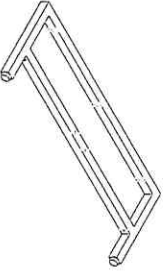

ⓖ

T4424912160KX

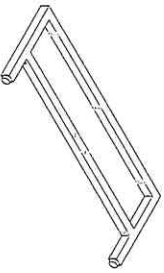

ⓗ

T4424912170KX

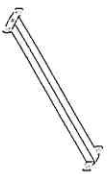

ⓓ

T4424912180KX

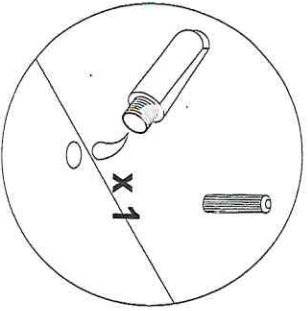
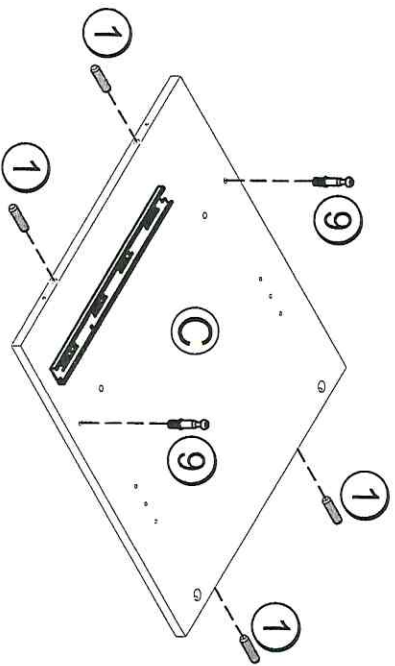
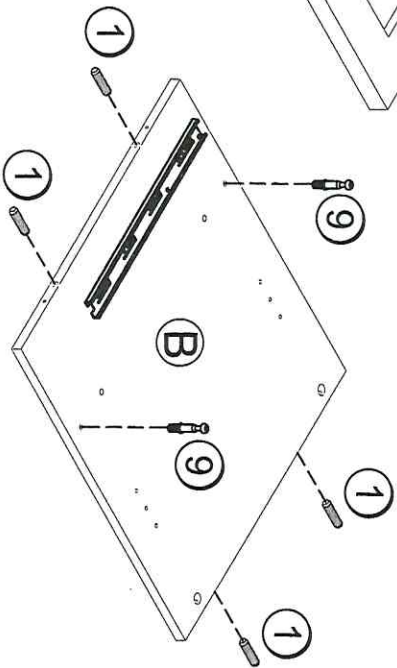
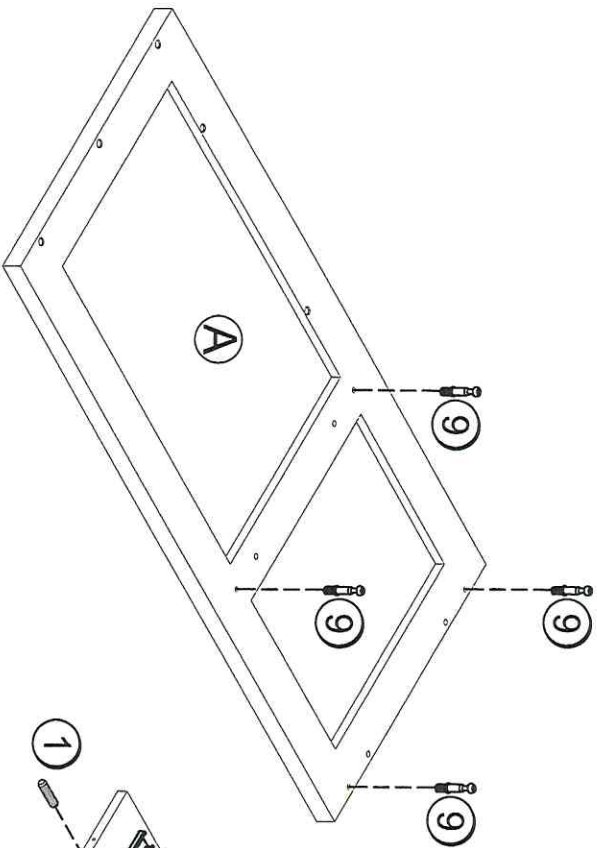
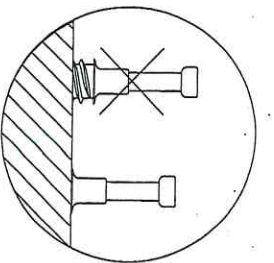
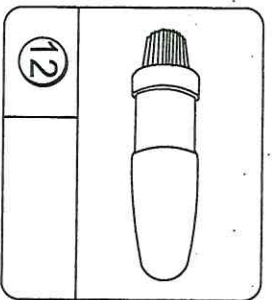
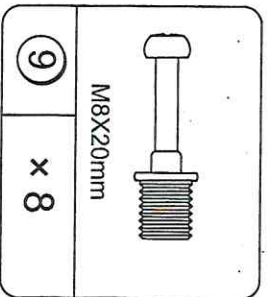
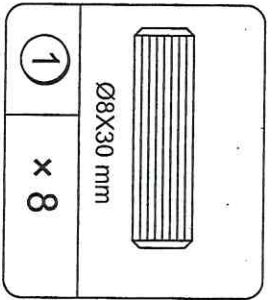
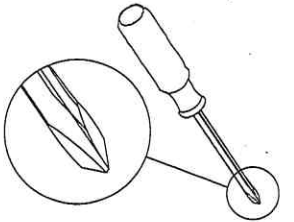

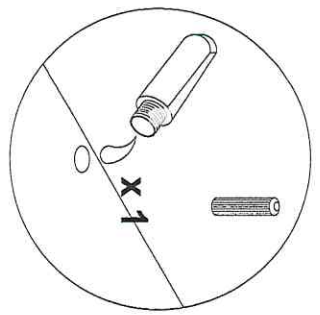
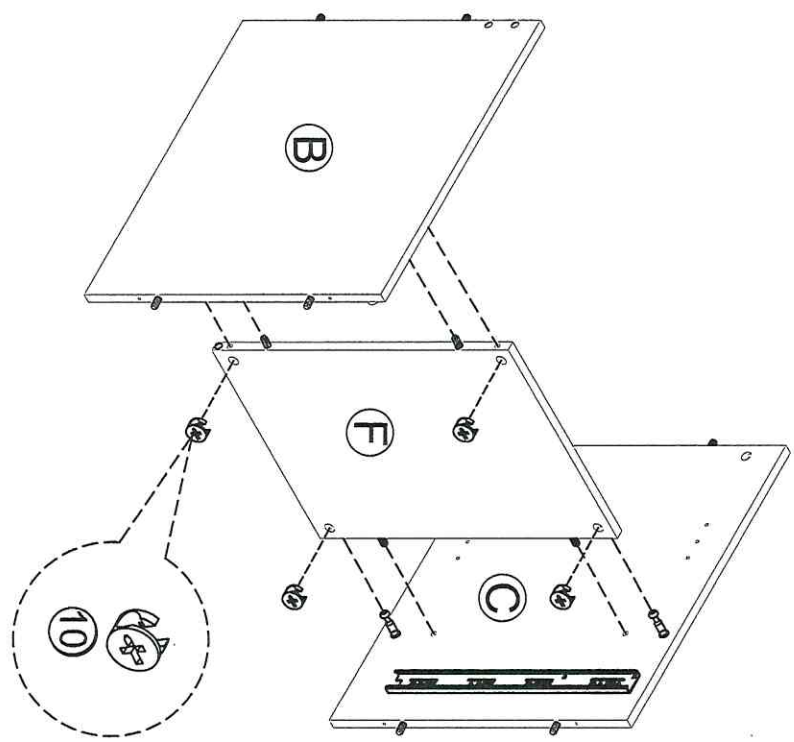
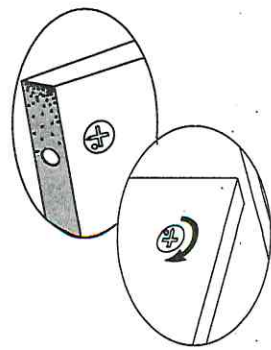
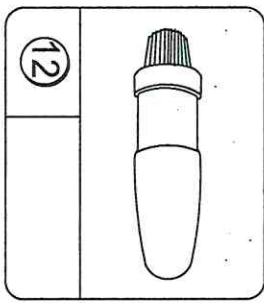
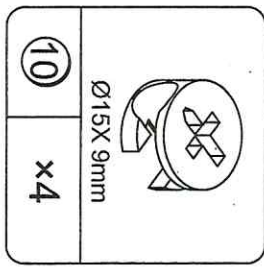
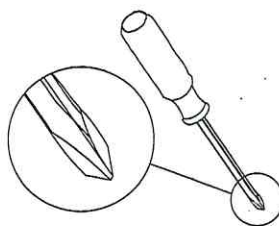

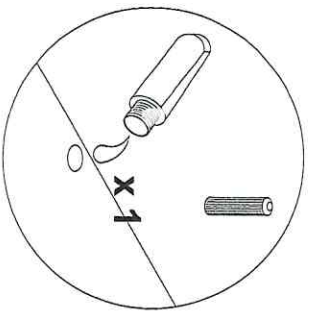
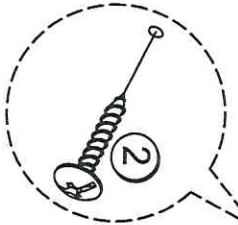
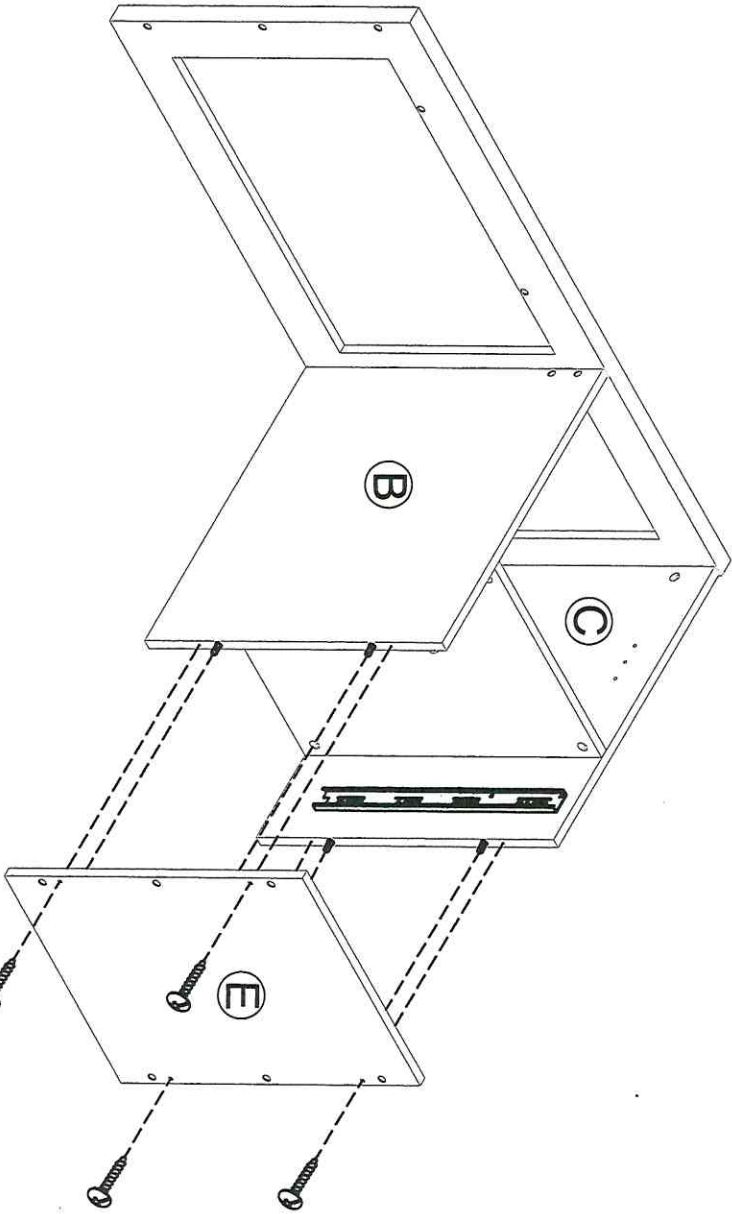
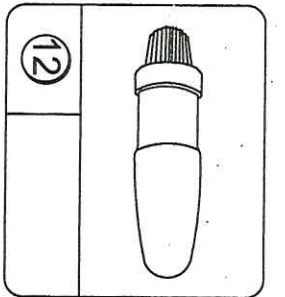
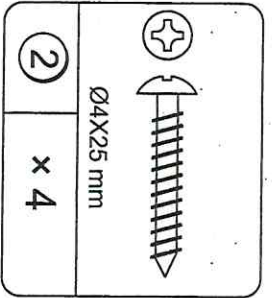
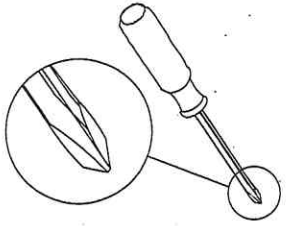

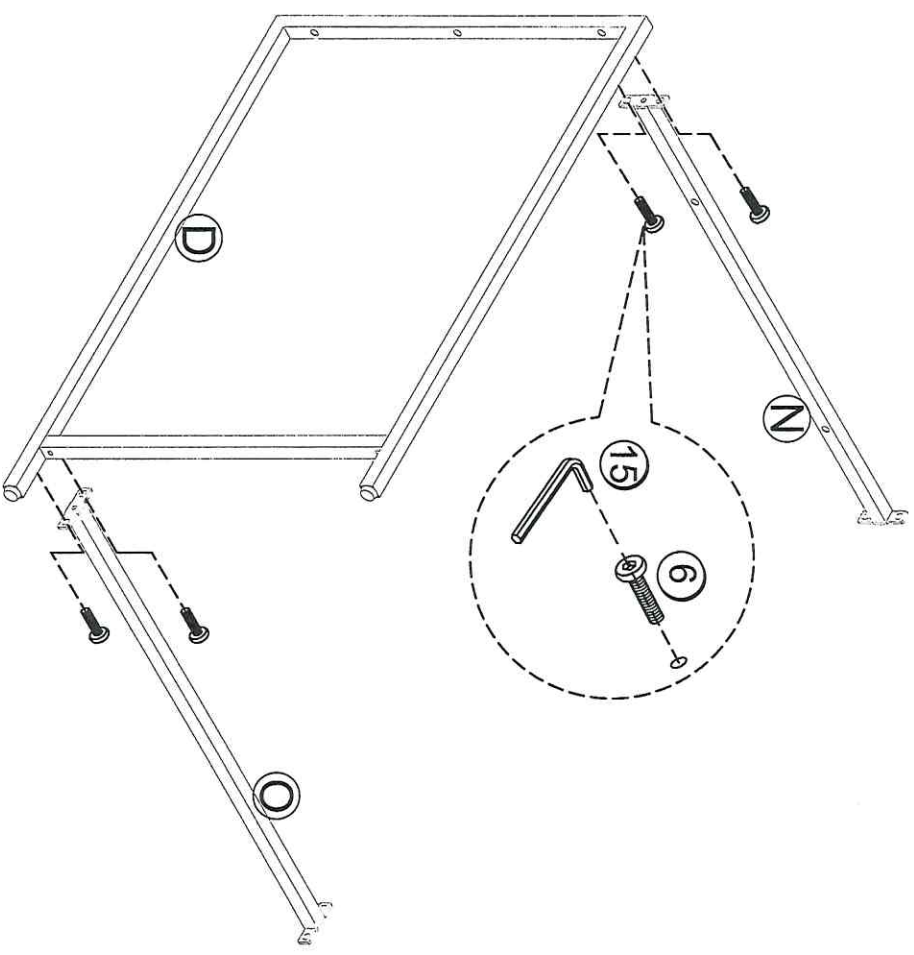
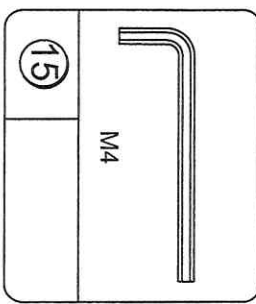
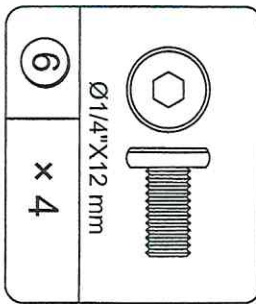

x 1

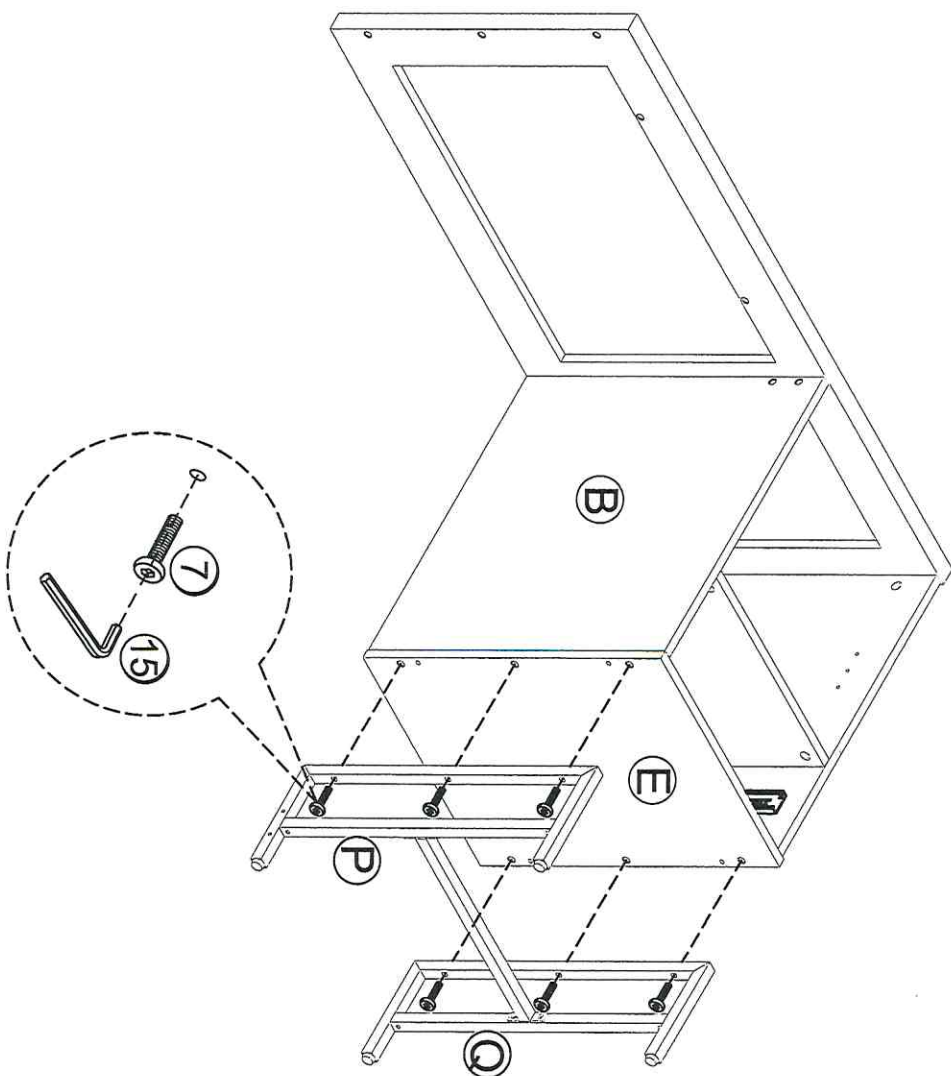
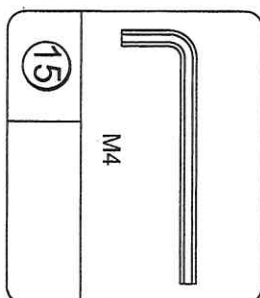
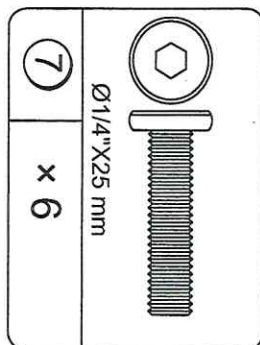

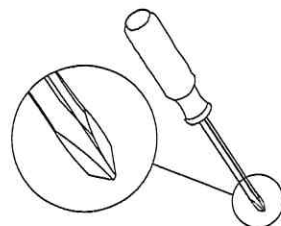



	
②	Ø4X25 mm x 4

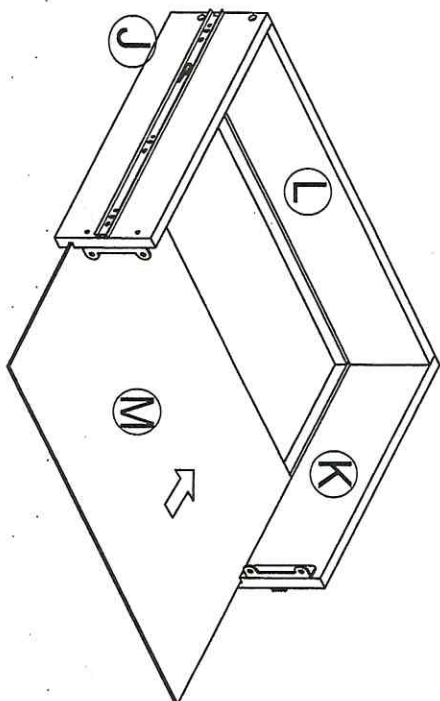
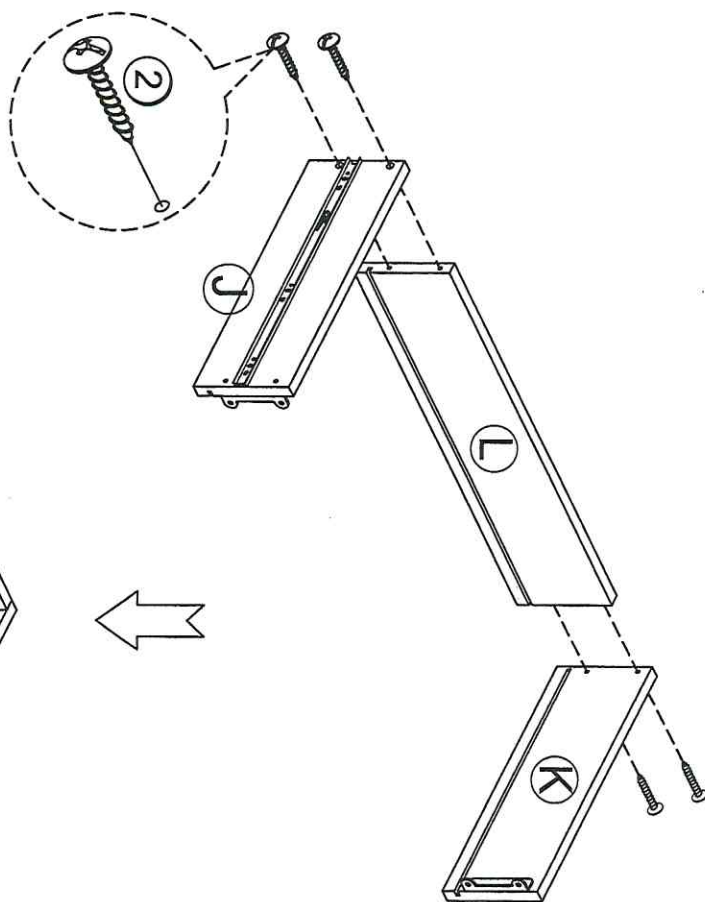

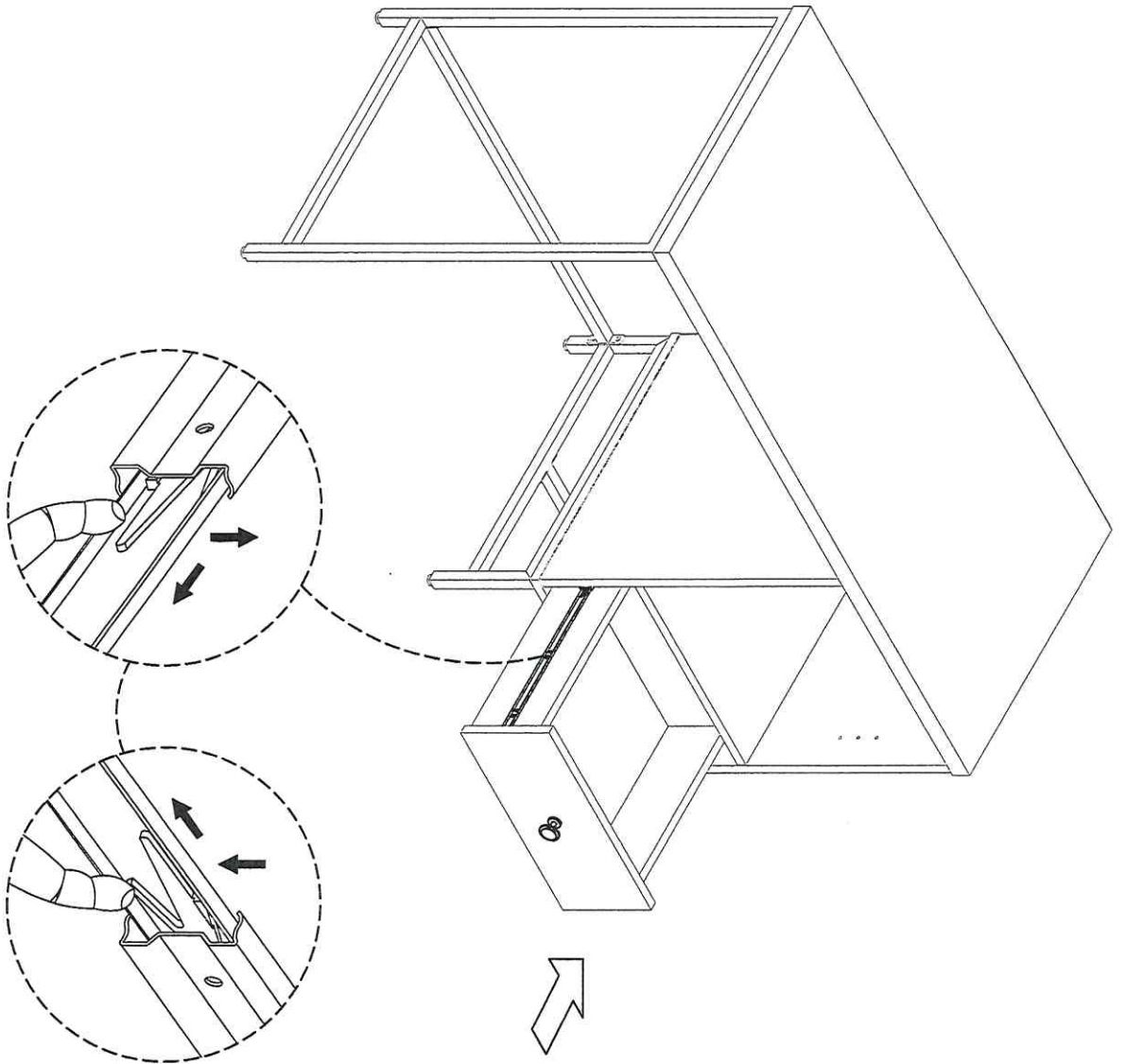

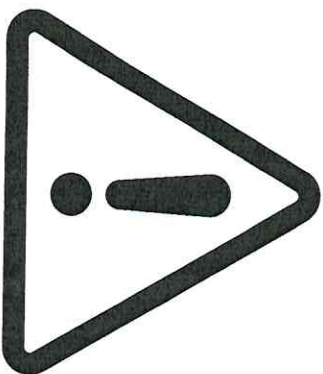

D	Überschreiten Sie die angegebenen Maximalbelastungen nicht. Andernfalls kann das Möbelstück beschädigt oder zerstört werden.
GB	Do not exceed the maximum loads specified. Otherwise, the furniture may sustain damage or be irreparably damaged.
FR	Ne dépassez pas les charges maximum indiquées. Sinon, le meuble peut être endommagé ou détruit.
IT	Non superare il carico massimo indicato. Altrimenti il mobile rischia di rovinarsi o frantumarsi.
NL	Overschrijd de aangegeven maximale belastingen niet. Anders kan het meubelstuk worden beschadigd of vernield.
PL	Nie wolno przekraczać podanych maksymalnych wartości obciążenia. W przeciwnym razie mebel może zostać uszkodzony lub zniszczony.
CZ	Nepřekračujte uvedená maximální zatížení. V opačném případě může dojít k poškození nebo zničení nábytku.
SK	Neprekročte uvedené maximálne zaťaženia. V opačnom prípade sa môže nábytok poškodiť alebo zničiť.
HU	Tartsa be az engedélyezett maximális terhelhetőség/teherbírásményt. Különben a bútor és annak alkotórészei megsérülhetnek, tönkre mehetnek.
RO	Nu depășiți solicitările maxime specificate. Altfel puteți să deteriorați sau să distrugeți piesa de mobilier.
TR	Belirtilen azami yük değerini aşmayınız, aksi takdirde mobilya parçaları zarar görebilir veya kullanılamaz hale gelebilir.
RU	Не допускаются превышение указанных максимальных нагрузок. В противном случае возможно повреждение или разрушение мебели.



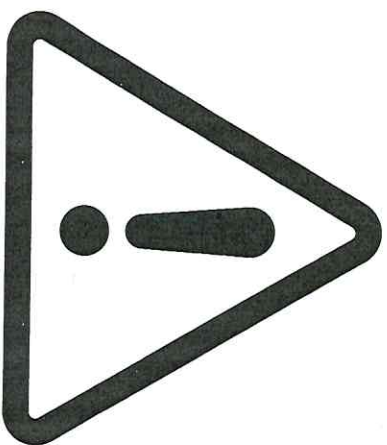

D	Ziehen Sie alle Schrauben sowie tragende Verbindungsteile nach ca. 5 Wochen nach, um eine dauerhafte Standsicherheit zu gewährleisten.
GB	After approx. 5 weeks, tighten all screws and load-bearing connecting parts to ensure permanent stability.
FR	Resserrez toutes les vis ainsi que les pièces de fixation au bout d'environ 5 semaines pour garantir une sécurité de fixation durable.
IT	Ristringere tutte le viti e giunture dopo ca. 5 settimane, al fine di garantire una durevole solidità.
NL	Draai alle schroeven en ook dragende verbindingstukken na ca. 5 weken nog eens vast, zodat een continue stabiliteit wordt gegarandeerd.
PL	Prosimy po ok. 5 tygodniach dokręcić wszystkie śruby w elementach łączeniowych. Zagwarantuje to Państwu trwałość i stabilność połączeń.
CZ	Dotáhněte všechny šrouby a nosné spojovací díly přibližně po 5 týdnech, aby se zaručila trvalá stabilita.
SK	Po cca 4 týždňoch dotiahnite skrutky, aby bola zaručená ich trvalá stabilita.
HU	Húzza utána – kb. 5 hét múlva – az összes csavarát és a teherhordó összekötő-alkatrészeket a biztonság érdekében.
RO	Pentru a asigura o stabilitate de durată, strângeți după cca. 5 săptămâni toate șuruburile, precum și toate elementele portante de legătură.
TR	Tüm vida ve taşıyıcı bağlantı parçalarını kalıcı bir duruş güvenciliğini sağlamak için yaklaşık 5 hafta sonra tekrar sıkınız.
RU	Подкрутите все болты, а также несущие соединительные детали прибл. через 5 недель для обеспечения устойчивости в течение длительного времени.
D	Bitte nur mit einem Staubwisch oder leicht feuchtem Lappen reinigen. Keine scheuernden Putzmittel verwenden.
GB	Please only clean with a duster or a damp cloth. Do not use any abrasive cleaners.
FR	Veillez nettoyer uniquement avec un chiffon à poussière ou un chiffon légèrement humide. Ne pas utiliser de détergent abrasif.
IT	Si raccomanda di pulire solo con un panno per la polvere o uno strofinaccio umido. Non utilizzare detergenti abrasivi.
NL	Reinig alleen met een stofdoek of een lichtjes vochtige doek. Gebruik geen schurende poetsmiddelen.
PL	Czyszczenie należy wykonać wyłącznie za pomocą ściereczki lub lekko nawilżonego ręcznika. Nie stosować środków czyszczących do szorowania.
CZ	Čistěte prosím jen prachovkou nebo lehce navlhčeným hadrem. Nepoužívejte drhnutí čistící prostředky.
SK	Na čistenie používajte len prachovku alebo zláhka navlhčenú utierku. Nepoužívajte žiadne drhnutie čistiace prostriedky.
HU	Kérjük, csak portörő kendővel vagy enyhén nedves ronggyal tisztítsa. Ne használjon dörzsható sú tisztítószert.
RO	Vă rugăm să utilizați la curățare exclusiv o cârpă de șters prafuri sau o cârpă ușor umezită. Nu utilizați substanțe de curățat abrazive.
TR	Lütfen sadece bir toz beziyile veya hafif nemli yumuşak bir bezle siliniz. Aşındırıcı temizlik malzemeleri kullanmayınız.
RU	Очищайте от пыли тряпкой или слегка влажной ветошью. Не допускаются применение чистящих средств, не предназначенных для ухода за мебелью.



Ø5 x 16mm

16

x 4

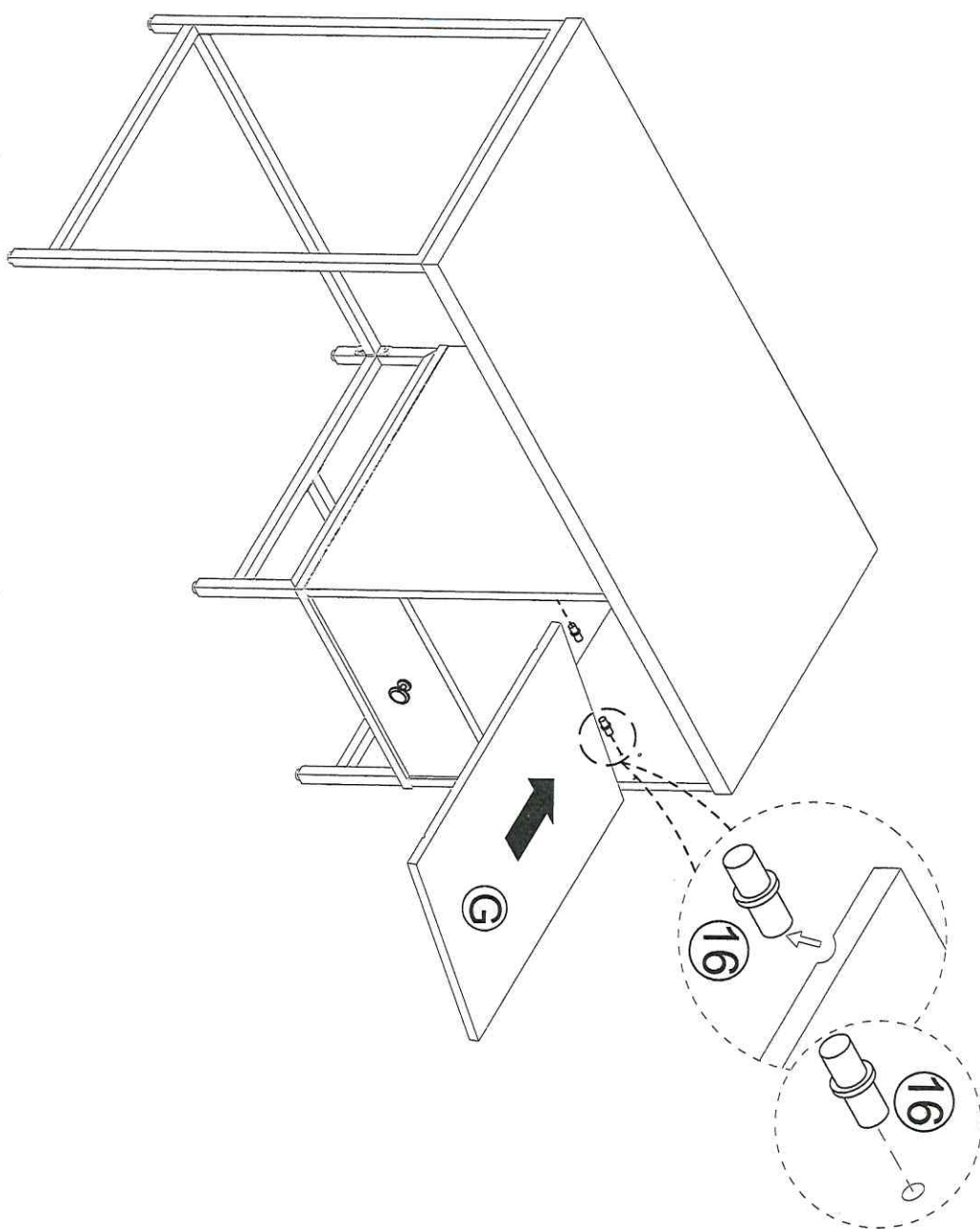

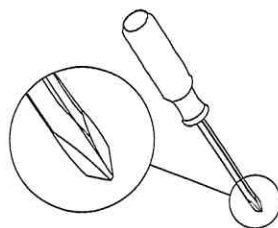

5	+		Ø3.5X12 mm
			x 4

8	+		Ø5/32"X22 mm
			x 1

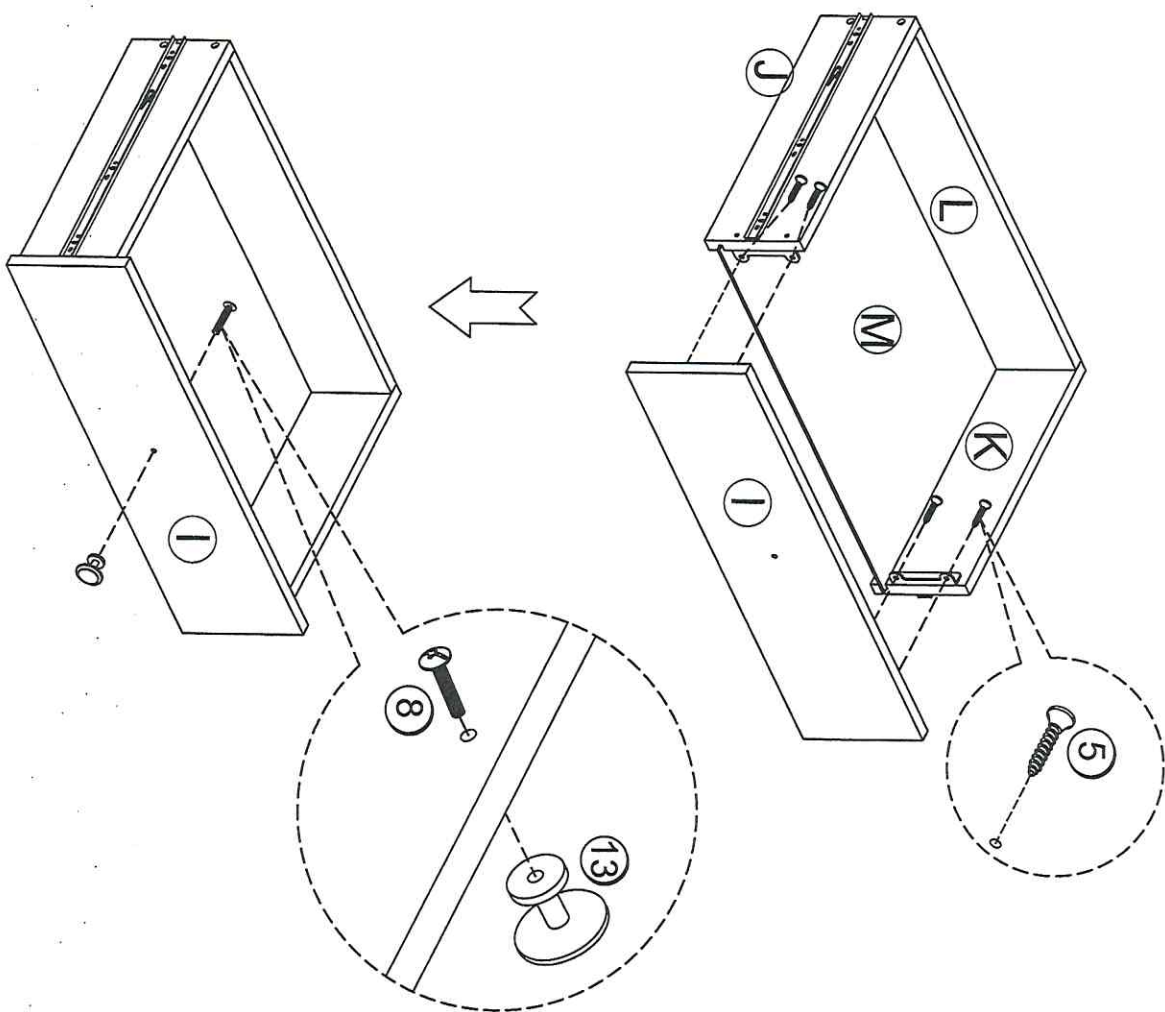

13			x 1
----	--	--	-----

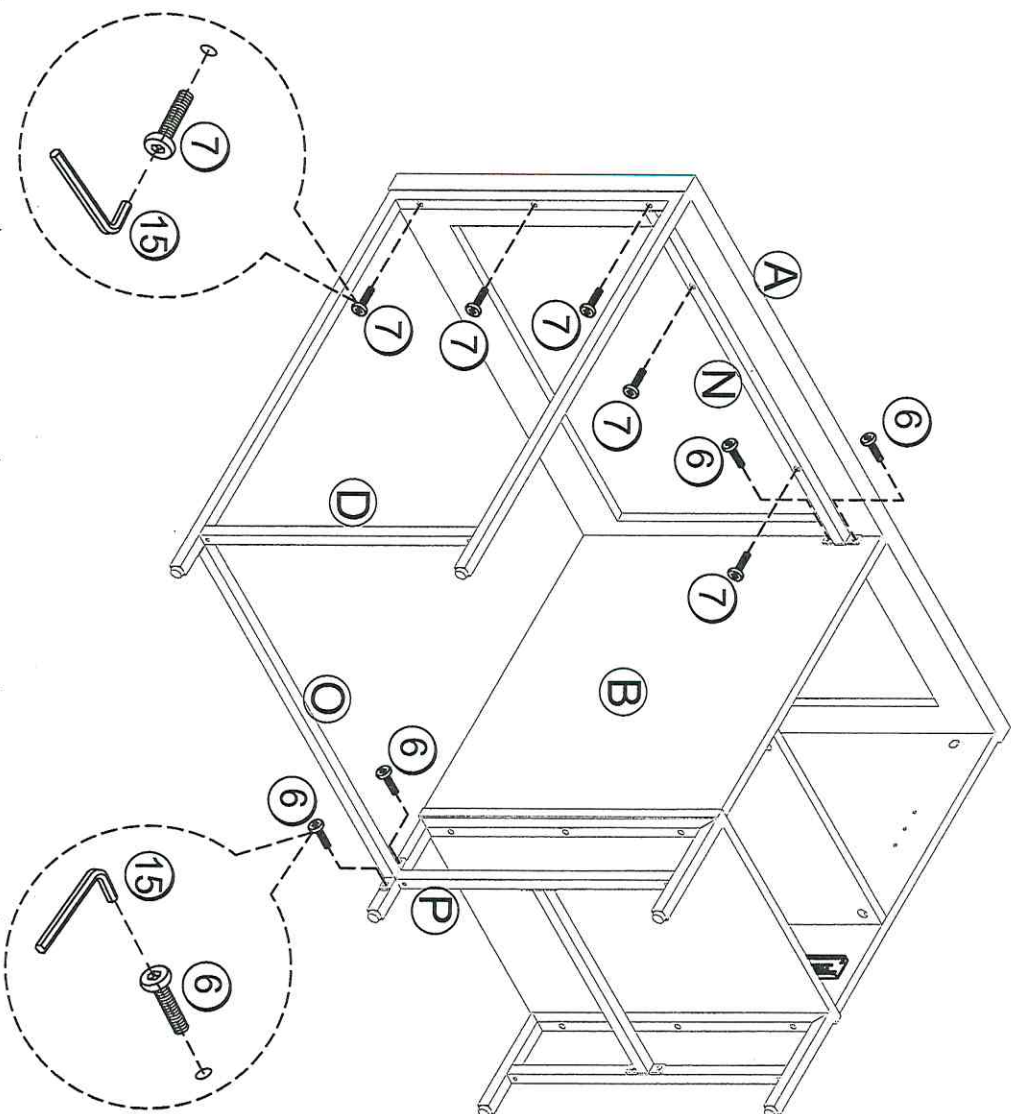
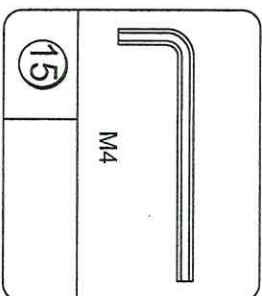
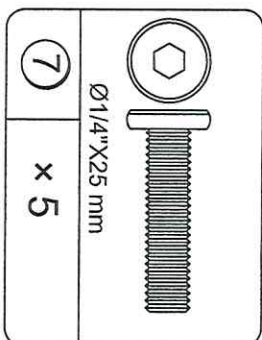
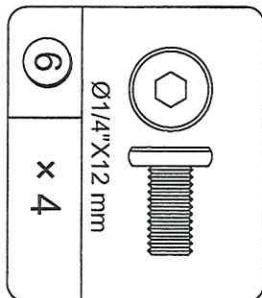

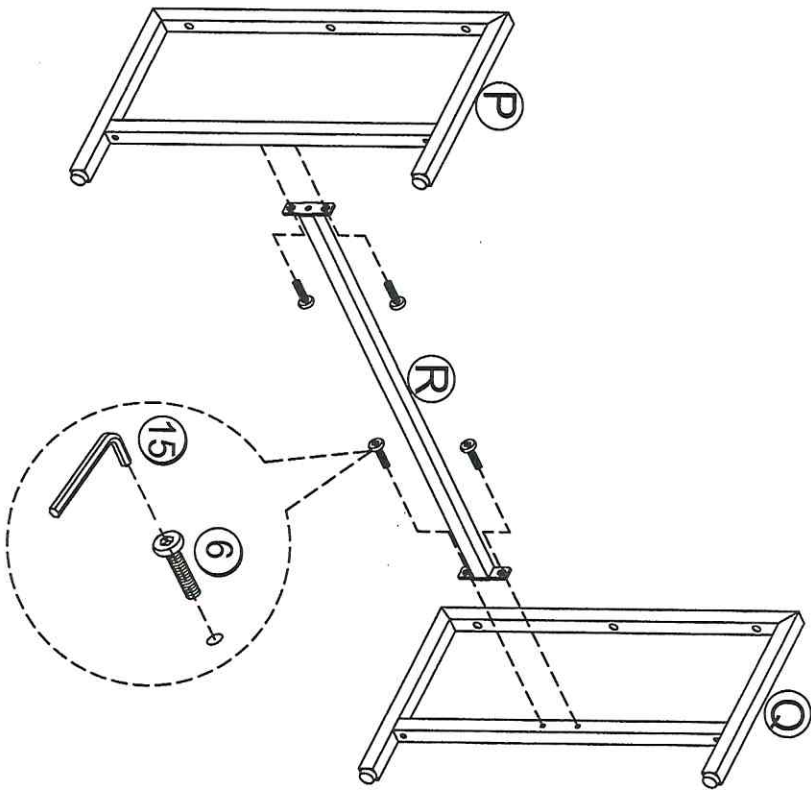
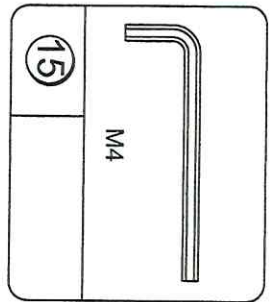
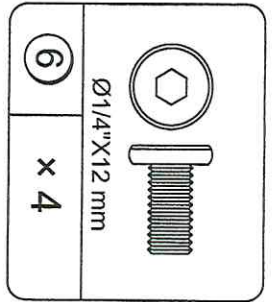

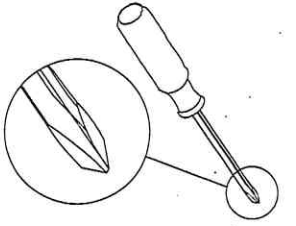



	
Ø3.5X12 mm	
4	x 16

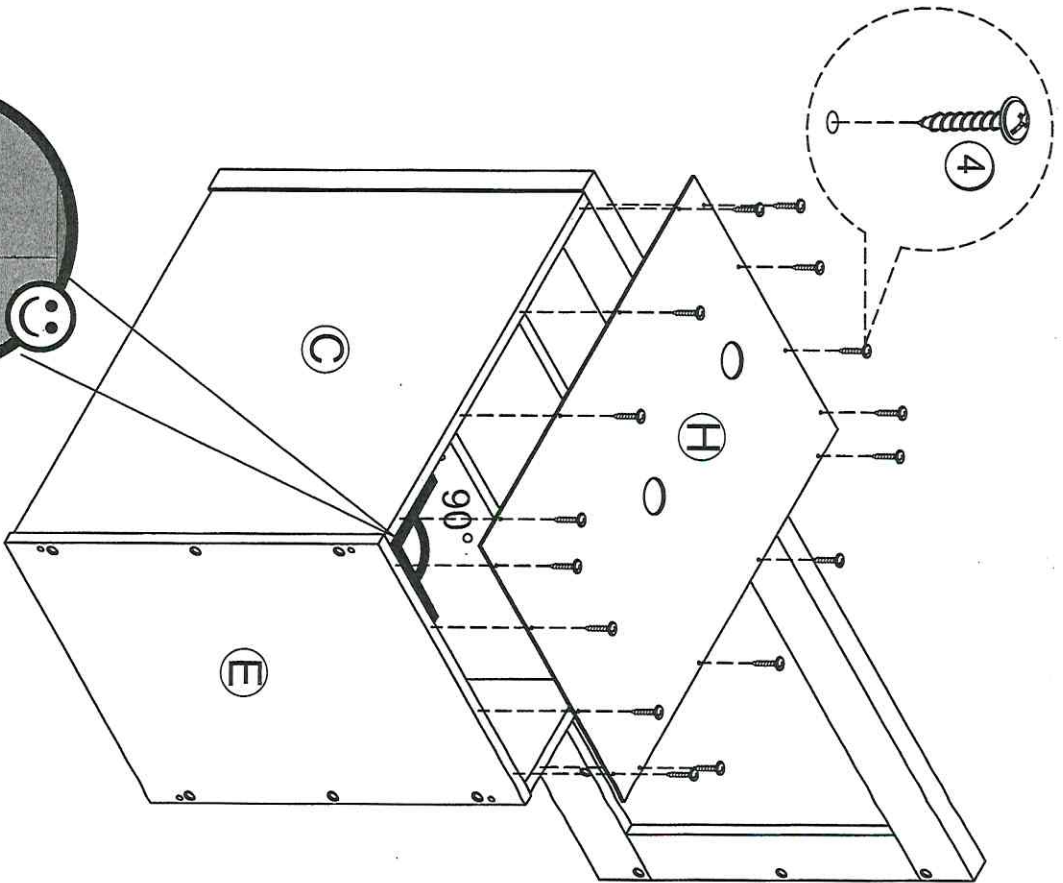
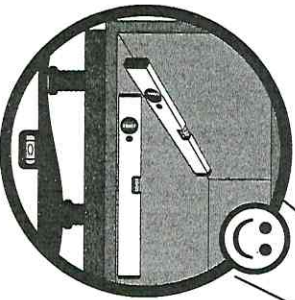

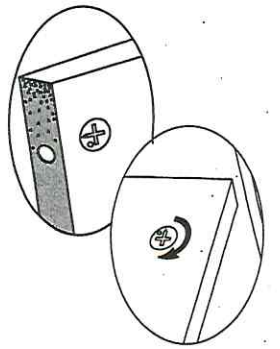
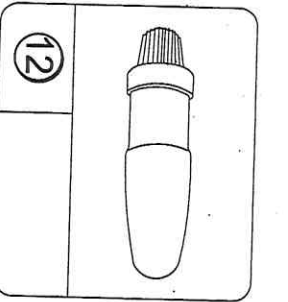
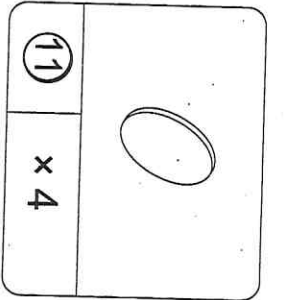
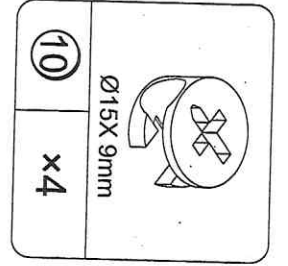
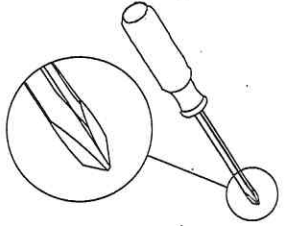
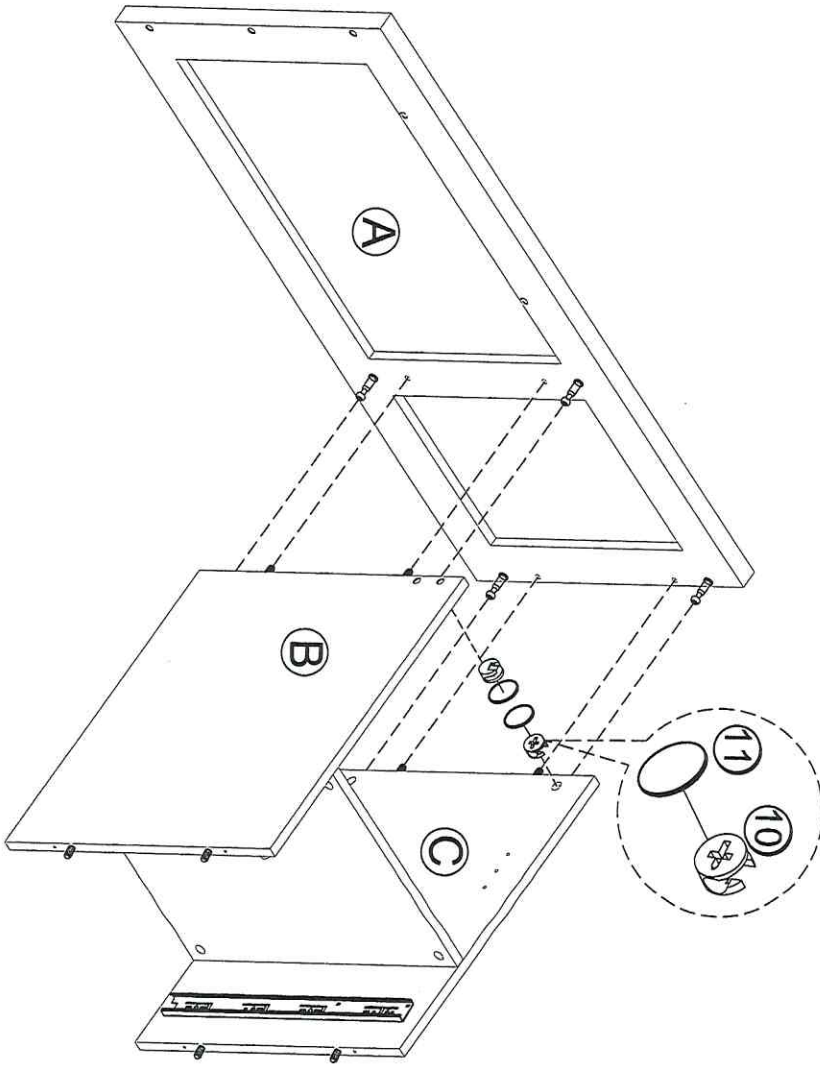
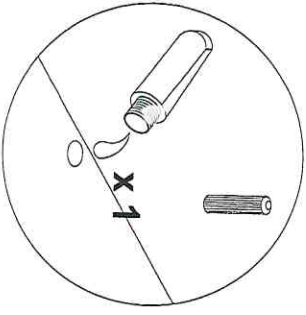

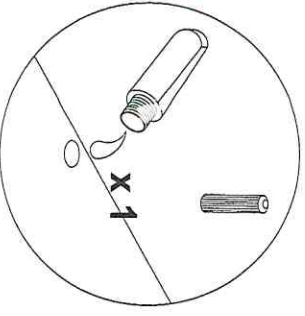
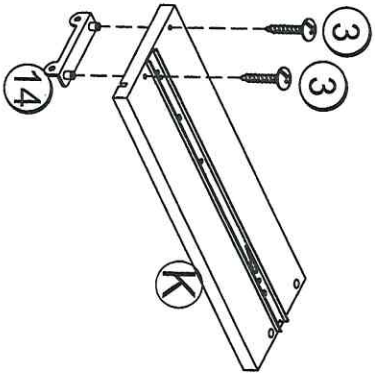
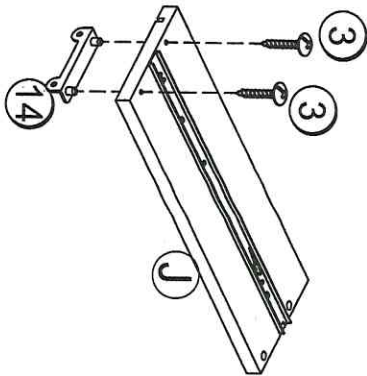
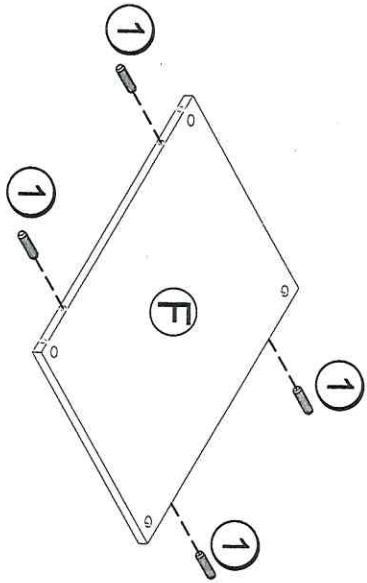
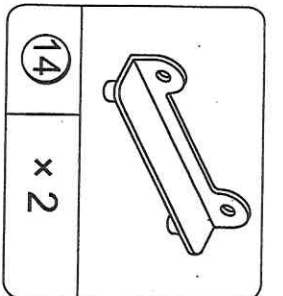
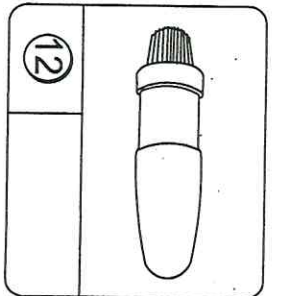
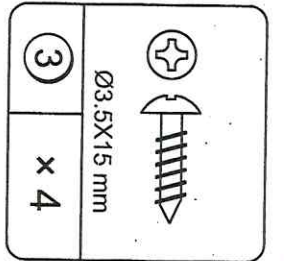
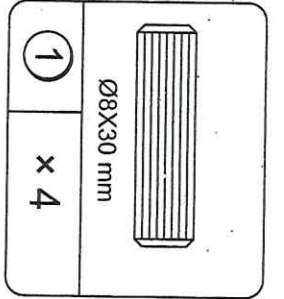
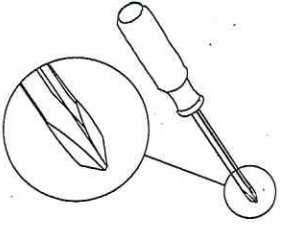

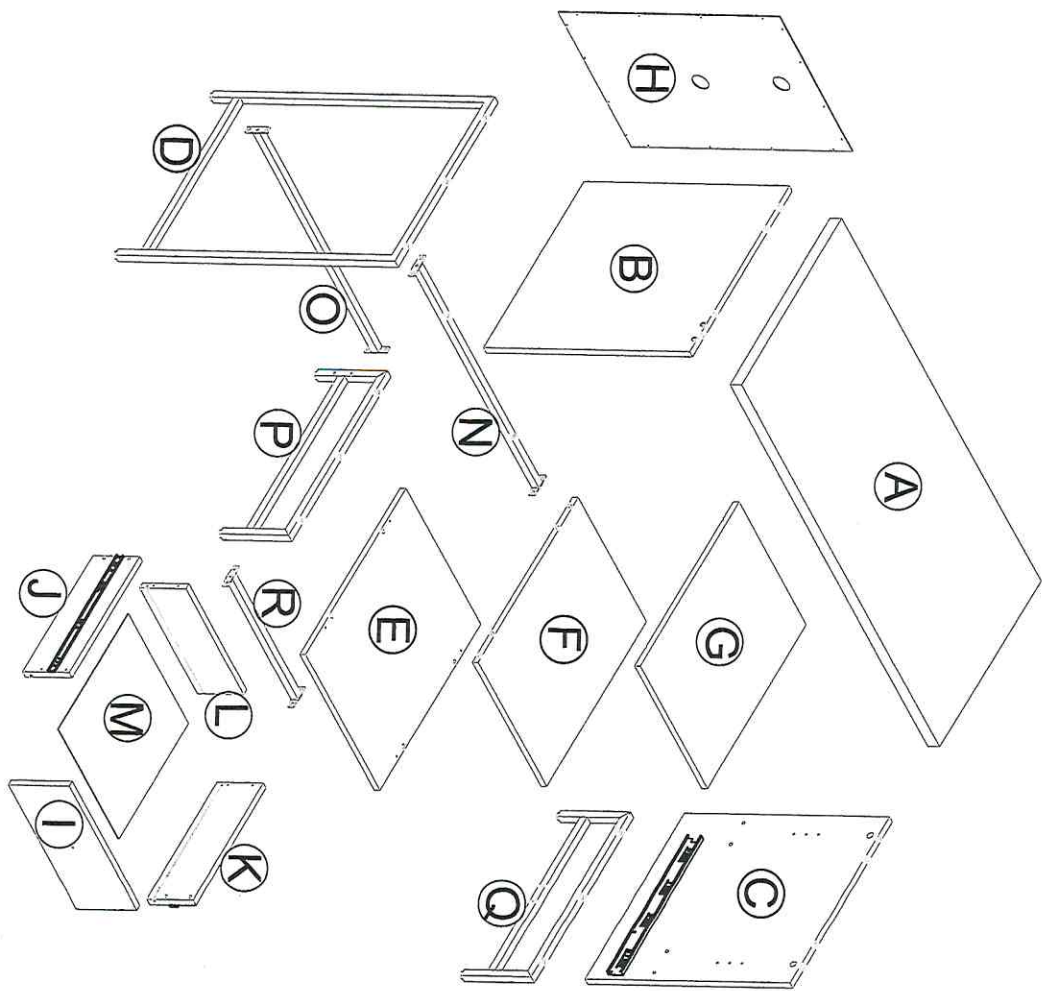

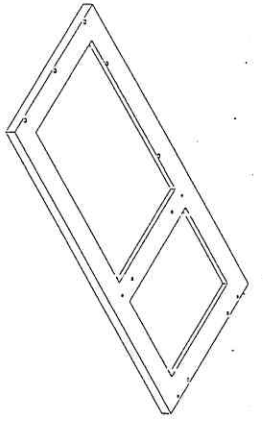

Ⓐ

T4424912010KX

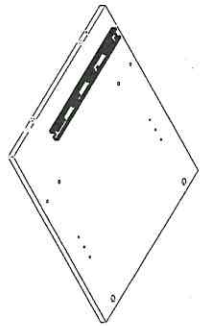

Ⓑ

T4424912020KX

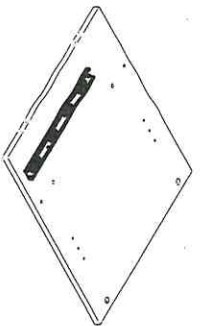

Ⓒ

T4424912030KX

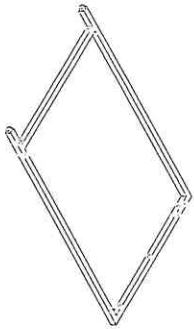

Ⓓ

T4424912040KX

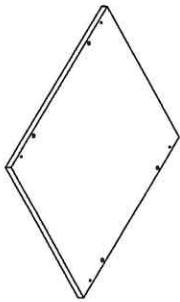

Ⓔ

T4424912050KX

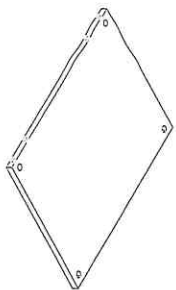

Ⓕ

T4424912060KX

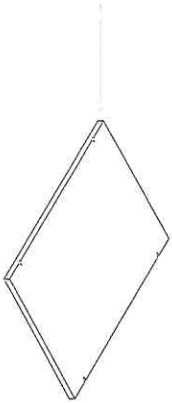

Ⓖ

T4424912070KX

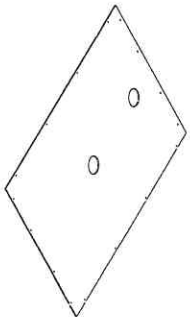

Ⓖ

T4424912080KX

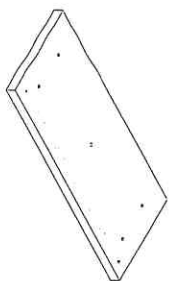

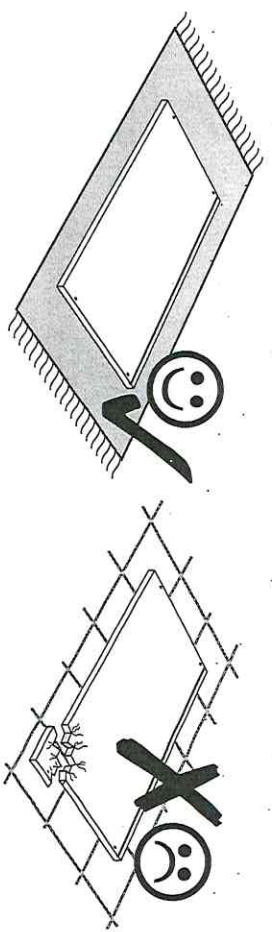
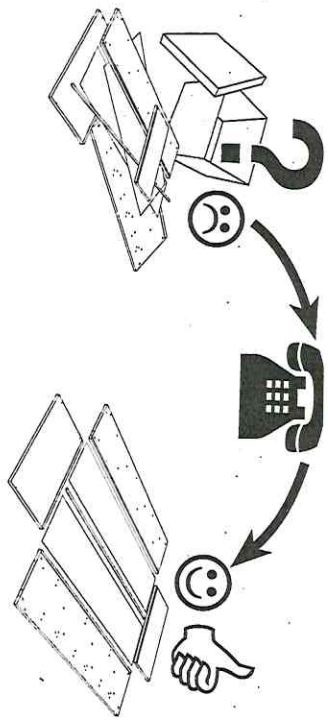

Ⓖ

T4424912090KX



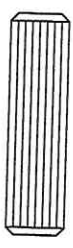

24424912COM0KX

	$\text{\O}8 \times 30 \text{ mm}$	1	x 12
	TKX1005		

	$\text{\O}4 \times 25 \text{ mm}$	2	x 8
	TKX1311		

	$\text{\O}3.5 \times 15 \text{ mm}$	3	x 4
	TKX1183		

	$\text{\O}3.5 \times 12 \text{ mm}$	4	x 16
	TKX1141		

	$\text{\O}3.5 \times 12 \text{ mm}$	5	x 4
	TKX1016		

	$\text{\O}1.4" \times 12 \text{ mm}$	6	x 12
	TKX1033		

	$\text{\O}1.4" \times 25 \text{ mm}$	7	x 11
	TKX1091		

	$\text{\O}5/32" \times 22 \text{ mm}$	8	x 1
	TKX1136		

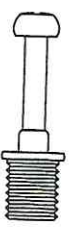
	$M8 \times 20 \text{ mm}$	9	x 8
	TKX1191		