

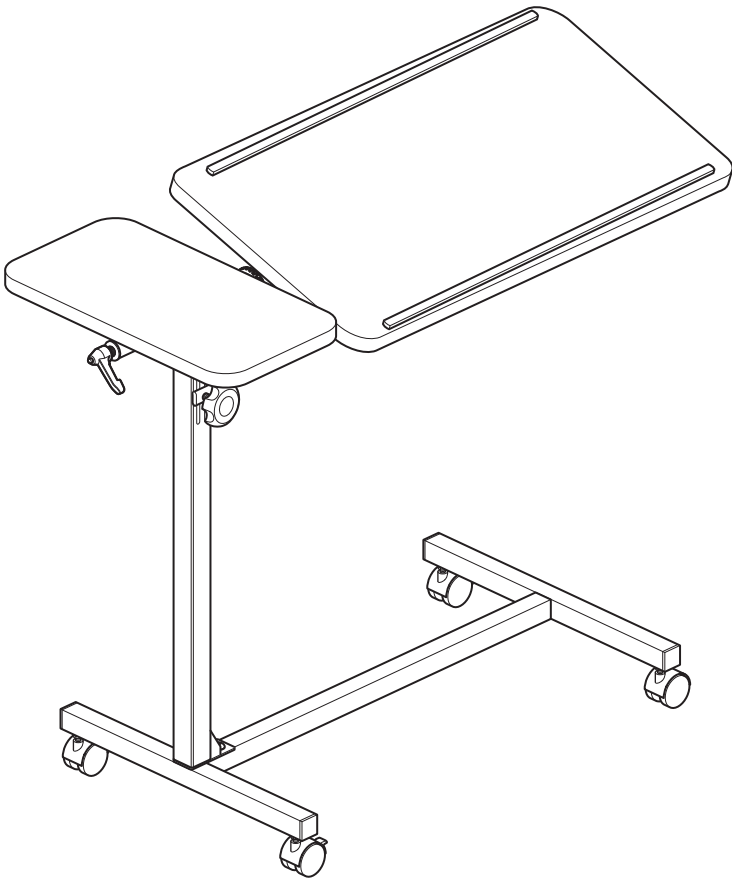

Twin Top Overbed Table (948)

Assembly & User Instructions



Please read these instructions carefully before assembling or using this product.
Ensure you are familiar with all of the safety and user instructions.

Retain all packaging until you have accepted the product.

Introduction

The Twin Top overbed table can be used in conjunction with a bed or a chair, and is ideal for reading, writing, using a laptop computer, etc.

It has two height adjustable tabletops, the larger of which is angle adjustable and has two lips to help prevent items slipping off the table.

The table is also highly portable, with a lightweight yet sturdy steel frame.

Drive Medical is an ISO 9001 certified company.

For more details about our products please see your local dealer.



Important Safety Information

Please read all of these instructions fully before assembly or using.

- Unpack and check that you have all of the parts shown.
- To avoid risk of suffocation to children or animals, dispose of the plastic bags correctly.
- Remove all packing materials and dispose of correctly, once the product has been accepted.
- Parts of the assembly are best carried out by 2 people.
- Ensure that only Drive parts are used on the table.
- The weight limit on the table is 15kg (33lb).
- The maximum advised height of the table is 94cm. Do not exceed this.
- When adjusting the table height/angle, the table will drop unless it is supported.
- For maximum stability, always try to keep heavy items near the centre of the table tops.
- The table is not suitable for leaning on, standing on, sitting on or any other similar load-bearing function.
- Periodically visually inspect the fixings and retighten if necessary.
- It is recommended that you remove any items on the table tops before moving it.
- This product should not be discarded with household waste. Take to your local authority waste disposal centre.

Keep these instructions for future reference.

Parts

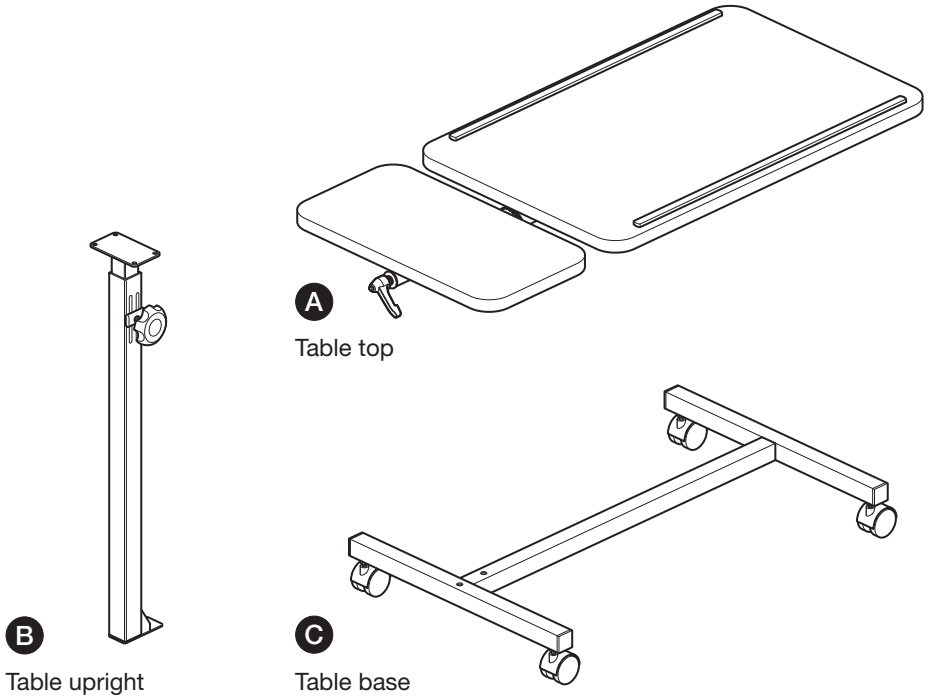

Hardware

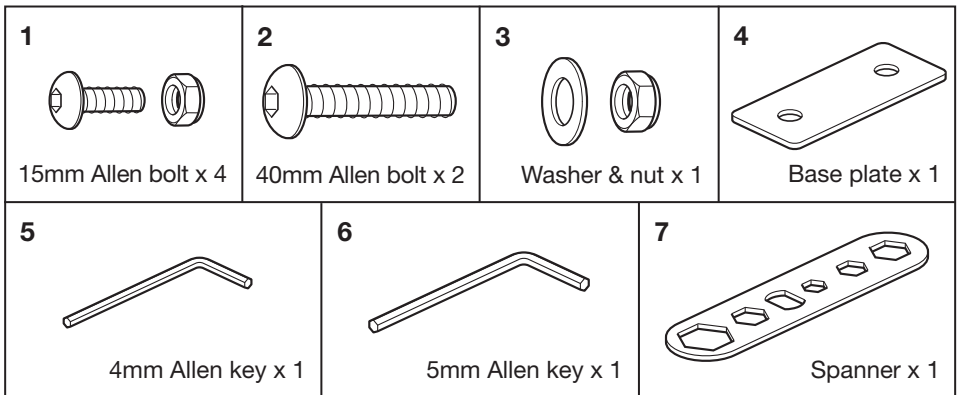
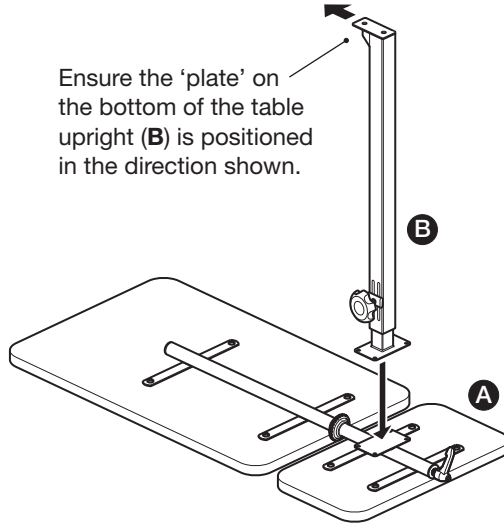
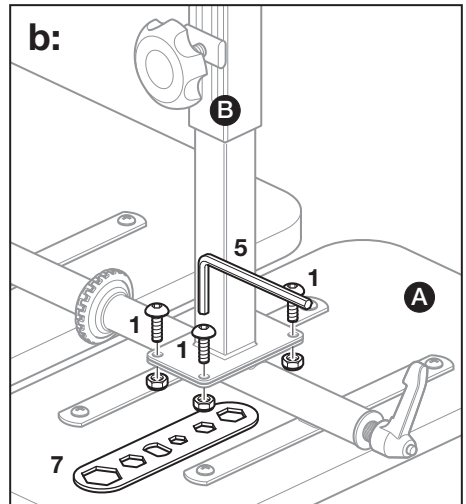
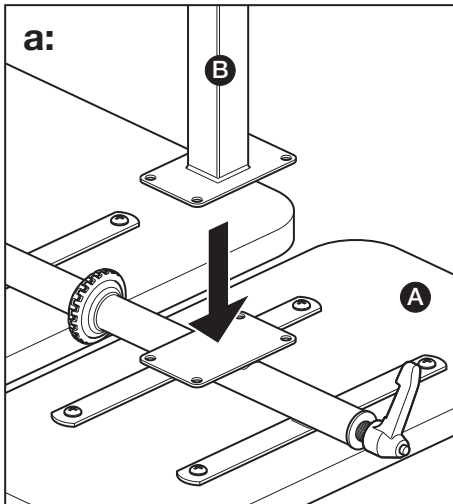

Table Assembly



Step 1



Step 1

Attach the table upright (B) to the table top (A).

a: Position the table upright (B) onto the plate on the underside of the table top (A).

b: Attach using 4 x 15mm allen bolts and nuts (1). Tighten using the supplied 4mm allen key (5) and spanner (7).

Table Assembly

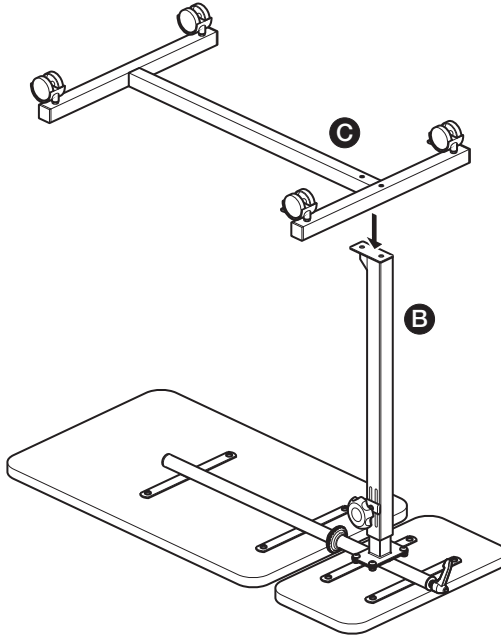

Step 2

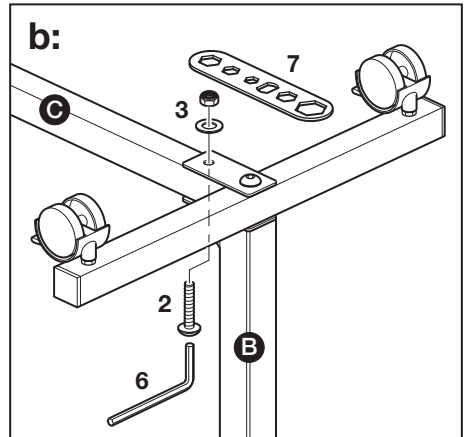
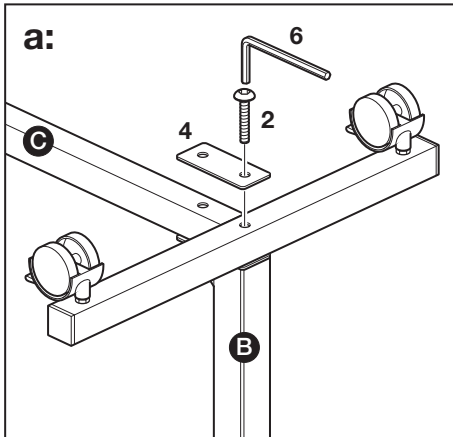

Step 2

With help, attach the table base (C) to the table upright (B).

a: Insert the 1st 40mm allen bolt (2) through the base plate (4), table base (C) and into the table upright (B). Tighten using the supplied 5mm allen key (6).

b: Insert the 2nd 40mm allen bolt (2) up through the table upright (B) and table base (C), fix using the washer and nut (3). Tighten using the supplied 5mm allen key (6) and spanner (7).

Assembly is now complete.

Table Adjustment

⚠ Caution:

- Remove all items from the table tops before any adjustments.
- When adjusting the table height/angle, the table will drop unless it is supported.
- Do not force the main table when adjusting the angle.

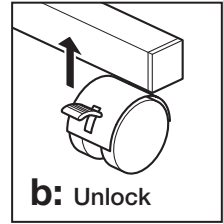
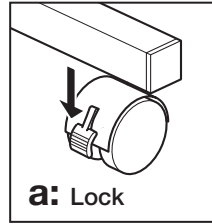

Locking / unlocking the wheels

a: To lock the wheels: Push the break catch down on each wheel.

b: To unlock the wheels: Lift the break catch up on each wheel.

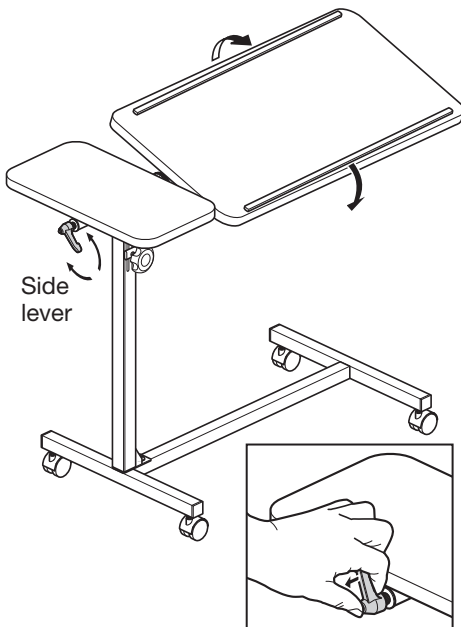

Table angle adjustment

Loosen the side lever (2 complete turns anti-clockwise). Adjust the angle as required and re-tighten the lever (turn clockwise) to lock in position.

Note: To rotate the lever out of the way (without loosening), press the button, pull out the lever and rotate as required.

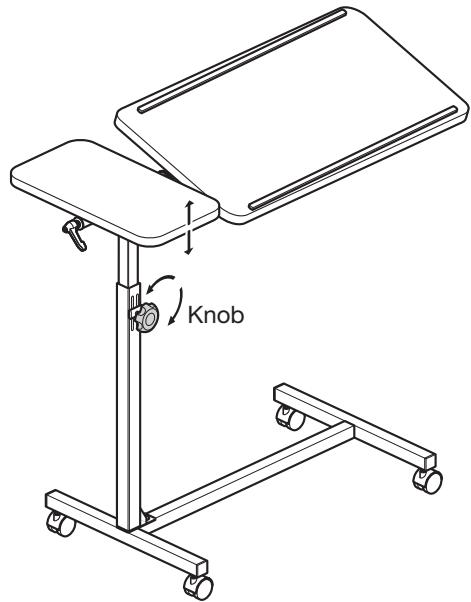

Table height adjustment

Loosen the knob (turn anti-clockwise). Adjust to the height required and re-tighten the knob (turn clockwise) to lock in position.

Spares Available

Z948 HGT: Height adjustment knob

Z948 BC: Castor (Braked)

Z948 ANG: Angle adjustment knob

Z948 UC: Castor (Unbraked)

Care and Maintenance

- The table can be wiped down with a warm damp cloth and mild disinfectant. Do not use hot water or abrasive cleaners as these can damage the table.
- The wooden parts of the table tops may be cleaned with a duster or dry cloth. Polish should not be used as this can cause abrasion of the wood.
- Periodically visually inspect the fixings and retighten if necessary.

Specifications

Model number: 948

Overall table dimensions:

45cm (D) x 77cm (W) x 66 - 94cm (H)

17¾" (D) x 30½" (W) x 26 - 37" (H)

Main tabletop dimensions:

45cm (D) x 60cm (W)

17¾" (D) x 23¾" (W)

Main tabletop dimensions:

45cm (D) x 15cm (W)

17¾" (D) x 6" (W)

Maximum load weight:

15kg (33lb)

Warranty

The overbed table carries a twelve-month warranty from date of purchase. This covers manufacturing and design defects. It does not cover wear and tear and accidental damage. Please see your dealer for full details of the warranty.

This does not affect your statutory rights.

Information on Disposal of old Equipment

This symbol indicates that equipment with this symbol should **NOT** be disposed of as general household waste. If you

want to dispose of the product, please consider the collection systems or facilities for appropriate recycling.



Products

drive[™]

Drive Medical Ltd

Ainley's Industrial Estate, Elland, West Yorkshire HX5 9JP

Web: www.drivemedical.co.uk