

# Overbed Table

## Assembly and Operation Instructions

The instructions below cover the 701 (two-wheel) and 946 (four-wheel) models of overbed table.

The overbed tables are height and angle adjustable. They feature a veneer style melamine tabletop with lipped edge for ease-of-use.

### Assembly Instructions

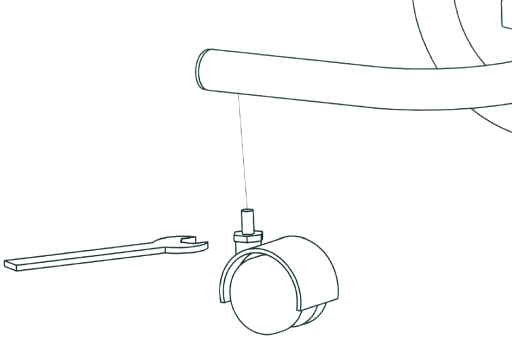

1. Fit Castors (if required) using a 13mm spanner (as shown in above diagram)

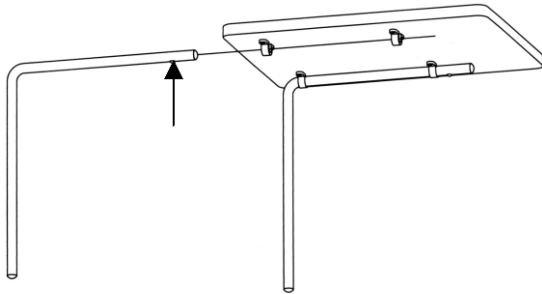

2. Insert the two chrome legs in the brackets located underneath the tabletop. Press the push button (arrowed) on the leg until slid through both of the brackets.

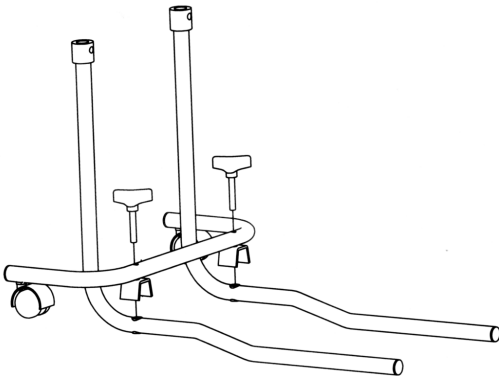

3. Use the two long handscrews to secure the 'C' shaped section to the two 'L' shaped sections.

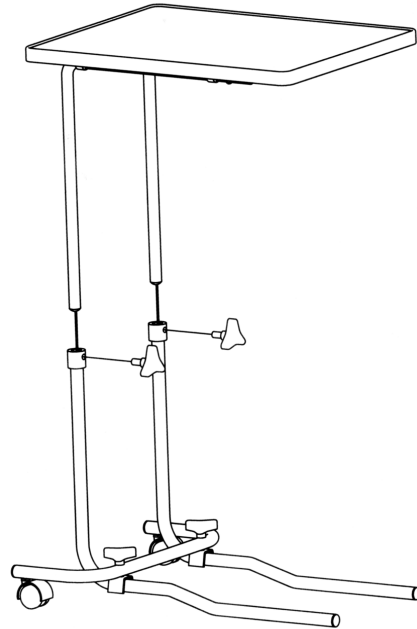

4. Connect the two sections of the table together as shown above. Adjust the tabletop to the required height and angle, then secure by screwing the 2 short handscrews clockwise into the 'L' sections.

### Operation Instructions

- To adjust the height and/or angle of the table, first slacken the 2 short handscrews by turning anticlockwise. Adjust the table to suit, and secure by turning handscrews clockwise.
- The table is not load bearing and should not be used to support objects over 15kg (33lb). Do not allow people to lean on the table.
- The table can be cleaned with a soft damp cloth and mild detergent. Using abrasive cleaning materials, very hot water or scrubbing the tabletop may result in damage.

### Dimensions

Tabletop (cm): 54(W) x 40(D) x 53 – 82(H)  
Table overall (cm): 60(W) x 43(D)

### Warranty

The overbed table comes with a one-year warranty covering manufacturing and design defects. It does not cover accidental damage or wear and tear. Contact your dealer for full warranty details.



Drive DeVilbiss Healthcare Ltd  
Holmfield, Halifax, HX2 9TN, Great Britain

Drive DeVilbiss Sidhil Ltd.  
Mallusk, Newtownabbey, BT36 4TY, Northern Ireland

[www.drivedevilbiss.co.uk](http://www.drivedevilbiss.co.uk)