

GUILD

600W Dual Action Car Polisher

Instruction Manual

PBP180

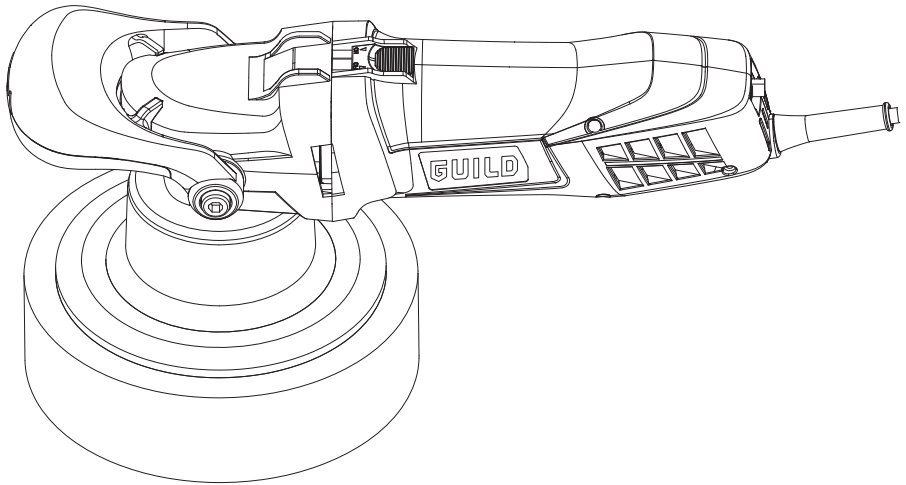

GUILD

After Sales Support

UK/Ireland 0333 3201989
Help@guildpowertools.co.uk

Important - Please read these instructions fully before operating or maintaining your Guild belt sander

These instructions contain important information that will help you get the best from your Guild Car Polisher, ensuring it remains safe to operate.

If you need help or have damaged or missing parts, call the Customer Helpline on 0333 3201989

Contents

Safety Information.....	3
In The Box.....	6
Accessories.....	6
Operating Instructions.....	7
Working Hints For Your Belt Sander.....	10
Maintenance.....	11
Technical Data.....	11
Environmental Protection.....	12
Guarantee.....	13
Plug Replacement (Uk & Ireland Only).....	14

Safety Information

Important - Please read these instructions fully before starting assembly

Warning Symbols

The following warning symbols appear throughout this assembly manual and indicate the appropriate safety measures you should take when assembling and operating the belt sander.



To reduce the risk of injury. Please read the instruction manual



Warning



Wear ear protection



Wear eye protection



Wear dust mask



Double insulation



Waste electrical products must not be disposed of with household waste. Please recycle where facilities exist. Check with your local authorities or retailer for recycling advice.

Safety Information

Important - Please read these instructions fully before starting assembly

General Power Tool Safety Warnings



WARNING! Read all safety warnings, instructions, illustrations and specifications provided with this power tool. Failure to follow all instructions listed below may result in electric shock, fire and/or serious injury.

Save all warnings and instructions for future reference.

The term "power tool" in the warnings refers to your mains-operated (corded) power tool or battery-operated (cordless) power tool.

1) Work area safety

- a) **Keep work area clean and well lit.** Cluttered or dark areas invite accidents.
- b) **Do not operate power tools in explosive atmospheres, such as in the presence of flammable liquids, gases or dust.** Power tools create sparks which may ignite the dust or fumes.
- c) **Keep children and bystanders away while operating a power tool.** Distractions can cause you to lose control.

2) Electrical safety

- a) **Power tool plugs must match the outlet. Never modify the plug in any way. Do not use any adapter plugs with earthed (grounded) power tools.** Unmodified plugs and matching outlets will reduce risk of electric shock.
- b) **Avoid body contact with earthed or grounded surfaces, such as pipes, radiators, ranges and refrigerators.** There is an increased risk of electric shock if your body is earthed or grounded.
- c) **Do not expose power tools to rain or wet conditions.** Water entering a power tool will increase the risk of electric shock.
- d) **Do not abuse the cord. Never use the cord for carrying, pulling or unplugging the power tool.** Keep cord away from heat, oil, sharp edges or moving parts. Damaged or entangled cords increase the risk of electric shock.
- e) **When operating a power tool outdoors, use an extension cord suitable for outdoor use.** Use of a cord suitable for outdoor use reduces the risk of electric shock.
- f) **If operating a power tool in a damp location is unavoidable, use a residual current device (RCD) protected supply.** Use of an RCD reduces the risk of electric shock.

3) Personal safety

- a) **Stay alert, watch what you are doing and use common sense when operating a power tool. Do not use a power tool while you are tired or under the influence of drugs, alcohol or medication.** A moment of inattention while operating power tools may result in serious personal injury.
- b) **Use personal protective equipment. Always wear eye protection.** Protective equipment such as dust mask, non-skid safety shoes, hard hat, or hearing protection used for appropriate conditions will reduce personal injuries.
- c) **Prevent unintentional starting. Ensure the switch is in the off-position before connecting to power source and/or battery pack, picking up or carrying the tool.** Carrying power tools with your finger on the switch or energising power tools that have the switch on invites accidents.

Safety Information

Important - Please read these instructions fully before starting assembly

General Power Tool Safety Warnings

- d) **Remove any adjusting key or wrench before turning the power tool on.** A wrench or a key left attached to a rotating part of the power tool may result in personal injury.
- e) **Do not overreach. Keep proper footing and balance at all times.** This enables better control of the power tool in unexpected situations.
- f) **Dress properly. Do not wear loose clothing or jewellery. Keep your hair and clothing away from moving parts.** Loose clothes, jewellery or long hair can be caught in moving parts.
- g) **If devices are provided for the connection of dust extraction and collection facilities, ensure these are connected and properly used.** Use of dust collection can reduce dust-related hazards.
- h) **Do not let familiarity gained from frequent use of tools allow you to become complacent and ignore tool safety principles.** A careless action can cause severe injury within a fraction of a second.

4) Power tool use and care

- a) **Do not force the power tool.** Use the correct power tool for your application. The correct power tool will do the job better and safer at the rate for which it was designed.
- b) **Do not use the power tool if the switch does not turn it on and off.** Any power tool that cannot be controlled with the switch is dangerous and must be repaired.
- c) **Disconnect the plug from the power source and/or remove the battery pack, if detachable, from the power tool before making any adjustments, changing accessories, or storing power tools.** Such preventive safety measures reduce the risk of starting the power tool accidentally.
- d) **Store idle power tools out of the reach of children and do not allow persons unfamiliar with the power tool or these instructions to operate the power tool.** Power tools are dangerous in the hands of untrained users.
- e) **Maintain power tools and accessories. Check for misalignment or binding of moving parts, breakage of parts and any other condition that may affect the power tool's operation. If damaged, have the power tool repaired before use.** Many accidents are caused by poorly maintained power tools.
- f) **Keep cutting tools sharp and clean.** Properly maintained cutting tools with sharp cutting edges are less likely to bind and are easier to control.
- g) **Use the power tool, accessories and tool bits etc. in accordance with these instructions, taking into account the working conditions and the work to be performed.** Use of the power tool for operations different from those intended could result in a hazardous situation.
- h) **Keep handles and grasping surfaces dry, clean and free from oil and grease.** Slippery handles and grasping surfaces do not allow for safe handling and control of the tool in unexpected situations.

5) Service

- a) **Have your power tool serviced by a qualified repair person using only identical replacement parts.** This will ensure that the safety of the power tool is maintained.

In The Box

Parts

- ① Front Handle
- ② On/Off Switch
- ③ Variable Speed Switch
- ④ Sanding Pad
- ⑤ Foam Pad
- ⑥ Spanner

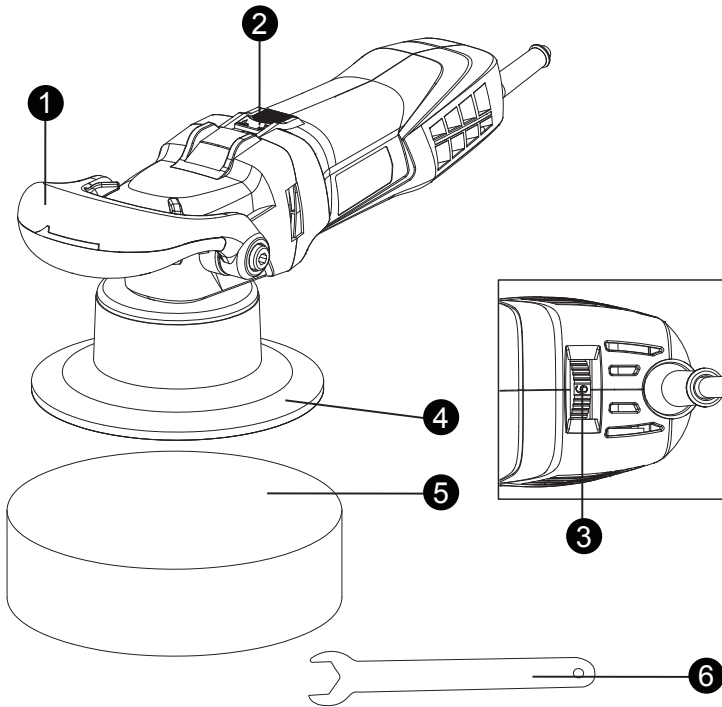

Accessories

Spanner (Thickness 3mm, suit to M4 bolt)
Foam pad (Diameter 180mm)

1pc
1pc

Operating Instructions



NOTE: Before using the tool, read the instruction book carefully.

1. ASSEMBLING OR CHANGING THE SANDING PAD [See Fig.A1-A2]



WARNING! Disconnect polisher from power source.

ASSEMBLY OF THE SANDING PAD

1. Take off the sanding pad [4] from the polisher.
2. Position the Spanner (a) (supplied with polisher) to engage the bolt (b) on the spindle.

NOTE:

1. It may be necessary to rotate the Sanding Pad (4) (by hand) to expose the spindle flats.
2. The thickness of spanner is 3mm so that you can easily match to the M4 bolt on the spindle.
3. While holding the spindle with the Spanner, rotate the Sanding Pad clockwise (by hand) to tighten it.

NOTE: There is a yellow gasket between sanding pad and bolt. When you change the sanding pad, please do not put it away, or machine will get stuck.

CHANGING THE SANDING PAD

1. Position the Spanner (a) (supplied with polisher) to engage the bolt (b) on the spindle.
2. While holding the spindle with the Spanner, rotate the old Sanding Pad counterclockwise (by hand) to remove it.
3. Install a new Sanding Pad as above instruction 'Assembly of the Sanding Pad'.

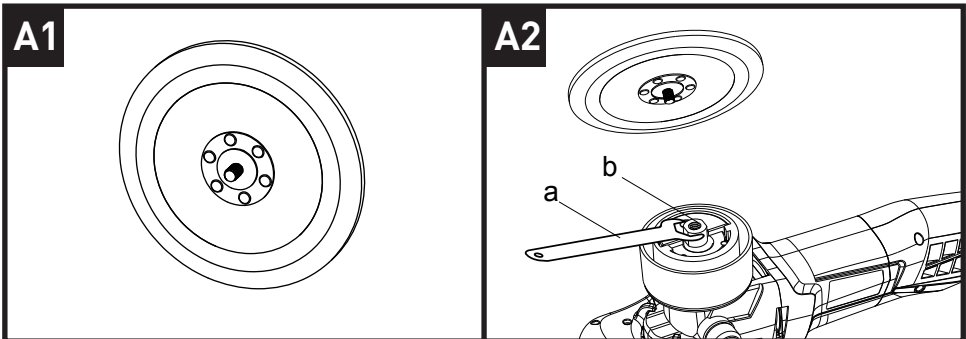

Operating Instructions

2. FITTING THE SANDING PAPER (NOT SUPPLIED) OR FOAM PAD (See Fig. B1,B2)

Sanding Paper (not supplied)/ or Foam Pad is easily attached on the pad of your polisher. Fit the paper/pad over the plate so that it covers the entire area, push and slightly twist to make sure the coated Sanding Paper/ or Foam Pad is even on the plate.

NOTE: Make sure the Sanding Paper/ or Foam Pad is even with the edges and that it's centrosymmetric, otherwise the polisher vibrates badly.

Remove the abrasive Sanding Paper/ or Foam Pad by pinching an edge and peeling it off.

3. SPREAD THE POLISH (See Fig. C)

Spread about a tablespoonful of polish evenly over the entire surface of the pad cover. Do not apply polish directly to car. This first application should do about 1/3 of an average size car. For the second and third applications of polish, repeat as above. Press gently until complete absorbed. We can spread and scrub wax in this step.

4. HAND GRIP AREAS (See Fig. D)

Always hold your car polisher firmly with both hands when operating.

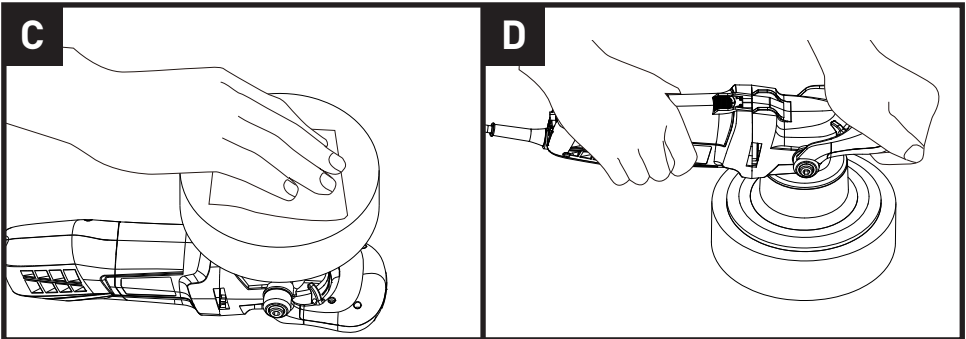
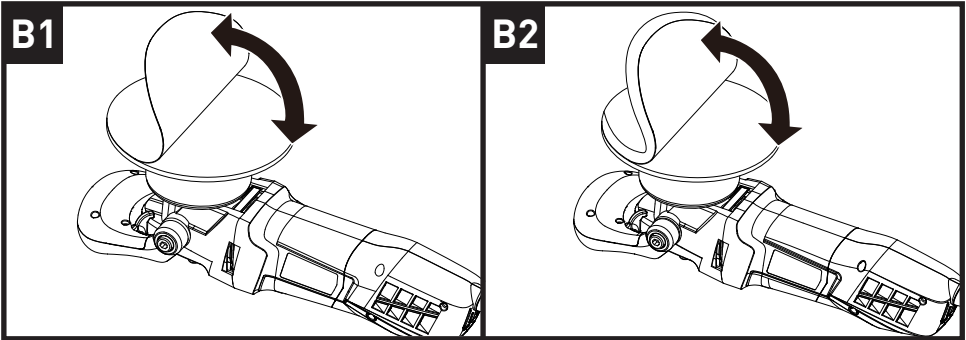

Operating Instructions

5. ON/OFF SWITCH (See Fig.E)

Always start and stop the polisher on against the car surface. Push the On/Off Switch (2) forward as the arrow of "I" position shown to start the polisher. Push the switch backward as the arrow of "O" position shown to stop the polisher.

6. VARIABLE SPEED SWITCH (See FIG.F)

The speed increases as you turn the Variable Speed Switch(3) towards the higher number and decreases on the lower number. When customer get the machine, the speed stuff is 6. Thumbwheel position 1 provides the slowest operating speed and position 6 the fastest. Speed may be changed while motor is running or while it is stopped.

7. TO USE THE CAR POLISHER (See Fig. G)

Hold extension cord over the shoulder and do flat surfaces first, i.e.: bonnet boot and roof. Cover areas quickly with broad sweeping strokes in a crisscross pattern. Do not press down on polisher. The machine without any pressure will automatically do the best job.

8. FINAL WORK (See Fig. H)

Use long, sweeping strokes in a criss-cross pattern to bring out the shine. Do not over-press the polisher.

9. SANDING

Choose sanding paper carefully for each application for best operation and finish.

To have the best sanding result, it is recommended to work with lower speed.

Use the sanding feature for sanding off old paint from timber and metal surface. It can also be used for sanding timber smooth.

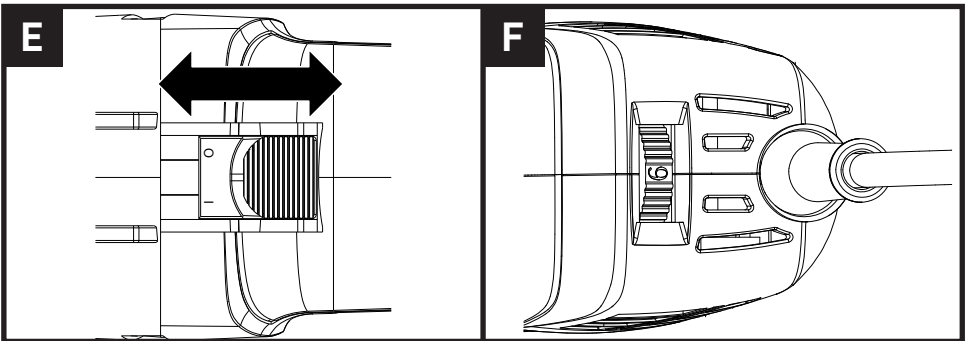

Operating Instructions

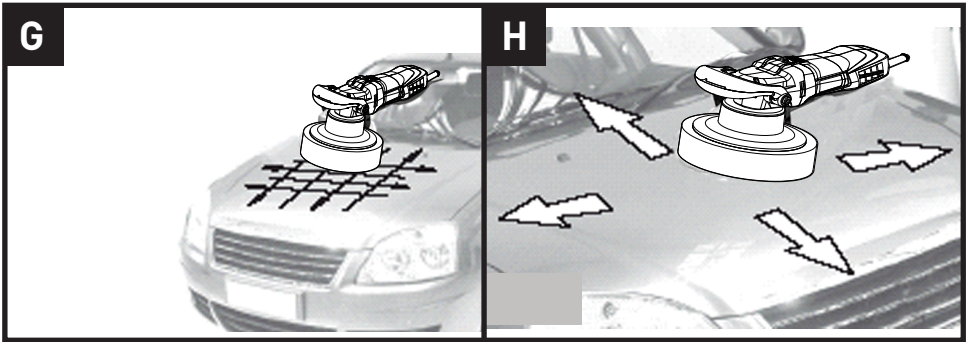

Working Hints For Your Belt Sander

1. At all times, let the polisher do the work-do not force it or apply excessive pressure to the polisher. Preferably, use a light circular motion. Pressing too hard will slow down the machine's movement and affect the quality of the work.
2. The most common error, however, is applying too much wax. If pad absorbs too much wax, it will not last as long, and polishing is more difficult and takes longer.
3. If bonnet continually comes off pad, please try with a new bonnet.
4. If wax seems difficult to buff, you may have used too much wax.
5. If you mistaid the spanner, you can buy other spanner whose thickness is 3mm and suit M4 bolt.
6. If you feel shake exceed your sustain, please have a rest and wear gloves.
7. When you assemble the pad, keep the alignment of sanding pad and form pad's axes.
8. Do not lose yellow gasket in the machine,when you assemble the sanding pad, or the machine may get stuck.

Maintenance

Remove the plug from the socket before carrying out any adjustment, servicing or maintenance.

Your power tool requires no additional lubrication or maintenance. There are no user serviceable parts in your power tool. Never use water or chemical cleaners to clean your power tool. Wipe clean with a dry cloth. Always store your power tool in a dry place. Keep the motor ventilation slots clean. Keep all working controls free of dust. Occasionally you may see sparks through the ventilation slots. This is normal.

If the supply cord is damaged, it must be replaced by the manufacturer, its service agent or similarly qualified persons in order to avoid a hazard.

Troubleshooting

1. If your router will not operate, check the power at the mains plug.
2. If a fault cannot be rectified, return the drill to an authorized dealer for repair.

Technical Data

Technical Data Table

Rated voltage	230-240V~50Hz
Rated input power:	600W
No-load speed:	1500-6800/min
Max. pad diameter:	180mm
Protection class:	□/II
Machine weight	2.46kg

Noise Information

A weighted sound pressure
A weighted sound power

L_{pA} : 80dB(A)
 L_{wA} : 91dB(A)
 K_{pA} & K_{wA} = 3.0dB(A)
80dB(A)

Wear ear protection

Vibration Information

Vibration total values (triax vector sum) determined according to EN 62841:
Vibration emission value $a_n = 2.3m/s^2$
Uncertainty $K = 1.5m/s^2$

The declared vibration total value may be used for comparing one tool with another, and may also be used in a preliminary assessment of exposure.

 **WARNING:** The vibration emission value during actual use of the power tool can differ from the declared value depending on the ways in which the tool is used dependant on the following examples and other variations on how the tool is used:
How the tool is used and the materials being cut or drilled.
The tool being in good condition and well maintained.
To use the correct accessory for the tool and ensuring it is sharp and in good condition.
The tightness of the grip on the handles and if any anti vibration accessories are used.
And the tool is being used as intended by its design and these instructions.

Technical Data

Vibration Information

This tool may cause hand-arm vibration syndrome if its use is not adequately managed.

 **WARNING:** To be accurate, an estimation of exposure level in the actual conditions of use should also take account of all parts of the operating cycle such as the times when the tool is switched off and when it is running idle but not actually doing the job. This may significantly reduce the exposure level over the total working period.

Helping to minimise your vibration exposure risk.

Maintain this tool in accordance with these instructions and keep well lubricated (where appropriate).

If the tool is to be used regularly then invest in anti vibration accessories.

Avoid using tools in temperatures of 10°C or less.

Plan your work schedule to spread any high vibration tool use across a number of days.

Environmental Protection



Waste electrical products must not be disposed of with household waste. Please recycle where facilities exist. Check with your local authorities or retailer for recycling advice.

Guarantee

This product is selected for DOMESTIC USE ONLY and not for business use.

This product is guaranteed against manufacturing defects for a period of 24 months. This does not cover the product where the fault is due to misuse, abuse, use in contravention of the instructions, or where the product has been the subject of unauthorised modifications or alterations, or has been the subject of commercial use. In the event of a problem with the product within the guarantee period please return it to your nearest store. If the item is shown to have an inherent defect present at the time of sale, the store will provide you with a replacement. Your statutory rights remain unaffected.

Issue1 08/2018

Plug Replacement (Uk & Ireland Only)

If you need to replace the fitted plug then follow the instructions below.

IMPORTANT

The wires in the mains lead are colored in accordance with the following code:

Blue – Neutral

Brown – Live

As the colors of the wires in the mains lead of this appliance may not correspond with the coloured markings identifying the terminals in your plug, proceed as follows. The wire which is coloured blue must be connected to the terminal which is marked with N. The wire which is coloured brown must be connected to the terminal which is marked with L.



WARNING:

Never connect live or neutral wires to the earth terminal of the plug. Only fit an approved BS1363/A plug and the correct rated fuse.

Note: If a moulded plug is fitted and has to be removed take great care in disposing of the plug and severed cable, it must be destroyed to prevent engaging into a socket.

