

ARCTIS 3

CONSOLE EDITION

PRODUCT INFORMATION GUIDE



CONTENTS

Welcome	2
Info and Table of contents	3–4
Product overview	5–6
Setup	7
Microphone	8
Headband Installation	9
Translations	
Español	10
简体中文	11
繁體中文	12
日本語	13
한국어	14
Deutsch	15
Русский	16
Français	17
Italiano	18
Português	19
Regulatory	21

WELCOME TO ARCTIS

Your new headset is the result of more than 15 years of gaming expertise and our unyielding pursuit of perfection. We poured our hearts into making your new Arctis, giving it the best gaming mic available, stunning audio quality and comfort and style unlike anything you've experienced before.



find help at support.steelseries.com

PACKAGE CONTENTS

Product Information Guide

Headset

Main Headset Cable

SYSTEM COMPATIBILITY

PS4

Xbox One

Switch

VR

PRODUCT OVERVIEW



*selected accessories available at steelseries.com

- 01 Ski Goggle Headband*
- 02 Main Headset Cable*
- 03 Airweave Ear Cushion*
- 04 Retractable Microphone
- 05 Microphone Mute Button
- 06 Volume Control
- 07 Main Cable Jack
- 08 Headphone Share Jack

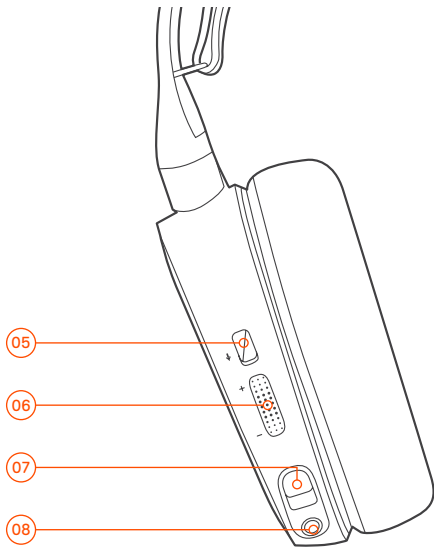

SETUP

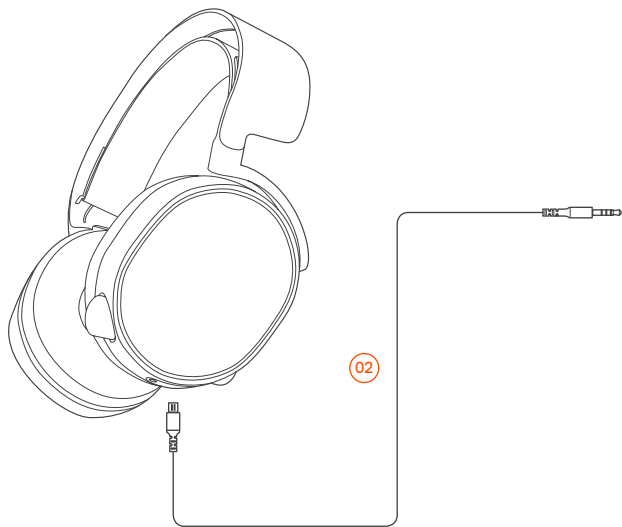

MICROPHONE

Retractable microphone

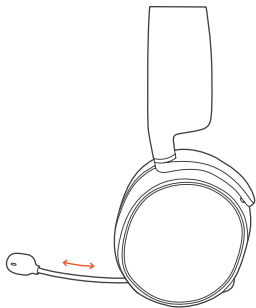

Positioning



top view



front view

Position the microphone close to the corner of your mouth with the flat surface facing you

SKI GOGGLE HEADBAND

accessory headbands available at steelseries.com

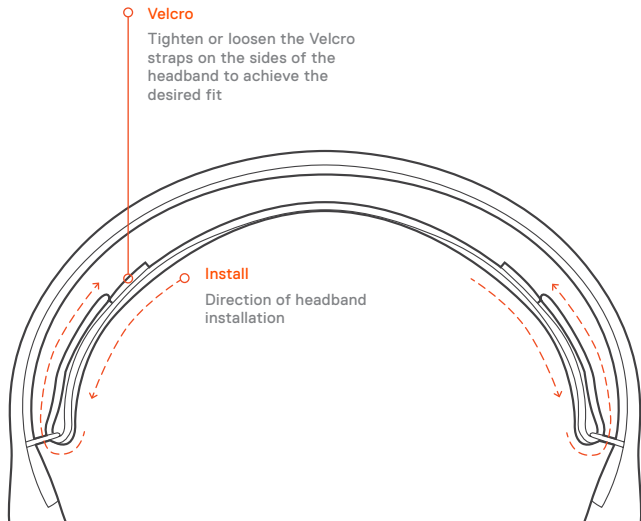

ESPAÑOL

CONTENIDO DEL PAQUETE

Guía de Información del Producto

Auriculares

Cable principal de los auriculares

REQUISITOS DEL SISTEMA // COMPATIBILIDAD

PS4 / XBOX ONE / SWITCH / VR

Solicite ayuda en support.steelseries.com

DESCRIPCIÓN GENERAL DEL PRODUCTO

- 01 Cinta para el cabello con gafas de esquí*
- 02 Cable principal de los auriculares*
- 03 Almohadilla para oídos Airweave*
- 04 Micrófono retráctil
- 05 Botón de silenciar el micrófono
- 06 Control del volumen
- 07 Conector del cable principal
- 08 Conector para compartir auriculares

* Los accesorios seleccionados están disponibles en steelseries.com

MICRÓFONO

Micrófono retráctil

Posicionamiento

Coloque el micrófono cerca de la esquina de su boca con la superficie plana hacia su rostro

Vista superior

Vista frontal

CINTA PARA EL CABELLO CON GAFAS DE ESQUÍ

Velcro

Ajuste o afloje las tiras de velcro de los laterales de la cinta para lograr el ajuste deseado.

Instalación

Instrucción para instalar la cinta para cabello

Más diademas aquí steelseries.com

简体中文

包装内含

产品信息指南

耳机

主耳机线

系统兼容性

PS4 / Xbox One / Switch / VR

访问 support.steelseries.com 寻求帮助

产品概览

- 01 滑雪镜头带*
- 02 主耳机线*
- 03 Airweave 耳罩*
- 04 伸缩式麦克风
- 05 麦克风静音按钮
- 06 音量控制
- 07 主线接口
- 08 耳机分享接口

* 勾选商品可在 steelseries.com 购买

麦克风

伸缩式麦克风

麦克风位置

将麦克风放置于靠近您嘴角处，宽平面朝向您自己。

鸟瞰图

正面图

滑雪镜头带

尼龙搭扣

加紧或放松头带两侧的尼龙搭扣调节松紧

安装

头带安装方法

更多头带样式请参考官网 steelseries.com

繁體中文

包裝內容

產品信息指南

耳機

主耳機線

系統兼容性

PS4 / Xbox One / Switch / VR

訪問 support.steelseries.com 尋求幫助

產品概覽

- 01 滑雪風鏡頭帶 *
- 02 主耳機線 *
- 03 Airweave 耳罩 *
- 04 伸縮式麥克風
- 05 麥克風靜音按鈕
- 06 音量控制
- 07 主線接口
- 08 耳機分享接口

* 訪問 support.steelseries.com 尋求幫助

麥克風

伸縮式麥克風

麥克風位置

將麥克風放置於靠近您嘴角處，寬平面朝向您自己。

鳥瞰圖

正面圖

滑雪風鏡頭帶

魔鬼氈

調整頭帶兩側的魔鬼氈至適宜鬆緊度

安裝

頭帶安裝方法

更多頭帶樣式請參考官網 steelseries.com

日本語

パッケージの内容

製品情報ガイド

ヘッドセット

メインケーブル

システム互換性

PS4 / Xbox One / Switch / VR

ヘルプについては support.steelseries.com をご覧ください

製品概要

- 01 スキーゴーグルヘッドバンド*
- 02 メインヘッドセットケーブル*
- 03 Airweave イヤークッション*
- 04 リトラクタブルマイク
- 05 マイク消音ボタン
- 06 音量コントロール
- 07 メインケーブルジャック
- 08 ヘッドフォン共有ジャック

* steelseries.com で厳選されたアクセサリをお求めいただけます

マイク

リトラクタブルマイク

ポジショニング

マイクの位置は、平らな面が口の端に来るように調節してください。

トップビュー

フロントビュー

スキーゴーグルヘッドバンド

面ファスナー

きつすぎず緩すぎない、丁度いい装着感になるように、ヘッドバンド両側のストラップの面ファスナーを調整してください。

インストール

ヘッドバンドの取り付け方法の説明です。

他のヘッドバンドをお求めの場合は steelseries.com をご覧ください

한국어

패키지 구성

제품 정보 가이드

헤드셋

메인 케이블

시스템 호환

PS4 / Xbox One / Switch / VR

도움말은 support.steelseries.com를 참조하십시오

제품 개요

- 01 스키고글 헤드밴드*
- 02 메인 헤드셋 케이블*
- 03 Airweave 이어패드*
- 04 접이식 마이크
- 05 마이크 음소거 버튼
- 06 볼륨 조절
- 07 메인 케이블 잭
- 08 헤드폰 공유 잭

* 선택된 액세서리는 steelseries.com에서 구할 수 있습니다

마이크

접이식 마이크

위치 조절

평평한 쪽이 얼굴을 향하도록 하여 마이크를 입가 근처에 고정시키십시오

평면 시점

정면 시점

스키고글 헤드밴드

벨크로

헤드셋 측면의 벨크로 띠의 부착을 조절하여 적절히 착용하십시오

설치

헤드밴드 설치 방향

steelseries.com 의 다른 헤드밴드 보기

DEUTSCH

PACKUNGSINHALT

Produktinformationen

Headset

Hauptkabel

KOMPATIBILITÄT

PS4 / Xbox One / Switch / VR

Hilfe findest du unter support.steelseries.com

PRODUKTÜBERBLICK

- 01 „Skibrillen“-Stirnband*
- 02 Haupt-Headset-Kabel*
- 03 Airweave Ohrpolster*
- 04 Einklappbares Mikrofon
- 05 Stummschalttaste des Mikrofon
- 06 Lautstärkeregler
- 07 Hauptkabelbuchse
- 08 Gemeinsame Kopfhörerbuchse

* Ausgewähltes Zubehör unter steelseries.com

MIKROFON

Einklappbares Mikrofon

Platzierung

Platziere das Mikrofon in die Nähe deines Mundwinkels, wobei die flache Oberfläche in deine Richtung deuten soll.

Ansicht von oben

Seitenansicht

„SKIBRILLEN“-STIRNBAND

Klettverschluss

Das Stirnband lässt sich anhand des Klettverschlusses auf die gewünschte Passform einstellen.

Installieren

Richtung der Stirnband-Installation

Weitere Stirnbänder bei steelseries.com

РУССКИЙ

СОДЕРЖИМОЕ УПАКОВКИ

Сведения об изделии

Наушники

Основной кабель

СИСТЕМНАЯ СОВМЕСТИМОСТЬ

PS4 / Xbox One / Switch / VR

Техподдержка support.steelseries.com

ОБЗОР ИЗДЕЛИЯ

- 01 Оголовье как у лыжных очков*
- 02 Основной кабель наушников*
- 03 Амбушюры Airweave*
- 04 Выдвижной микрофон
- 05 Кнопка отключения микрофона
- 06 Настройка громкости
- 07 Переходник основного кабеля
- 08 Переходник для второго пользователя

* Аксессуары steelseries.com

МИКРОФОН

Выдвижной микрофон

размещение

Расположите микрофон около уголка рта, плоской стороной к себе.

Вид сверху

Вид спереди

ОГОЛОВЬЕ КАК У ЛЫЖНЫХ ОЧКОВ

Велкро

Затяните или ослабьте полосы Велкро по бокам оголовья, чтобы оно лучше сидело

устанавливать

Направление установки оголовья

Другие модели steelseries.com

FRANÇAIS

CONTENU DE L'EMBALLAGE

Guide d'informations produit

Casque audio

Câble principal

COMPATIBILITÉ DU SYSTÈME

PS4 / Xbox One / Switch / VR

vous obtiendrez de l'aide ici
support.steelseries.com

PRÉSENTATION DU PRODUIT

- 01 Serre-tête de masque de ski*
- 02 Câble principal du casque audio**
- 03 Coussinet d'oreille Airweave*
- 04 Microphone rétractable
- 05 Bouton Muet du microphone
- 06 Contrôle du volume
- 07 Prise câble principal
- 08 Prise partage casque audio

* Sélection d'accessoires disponibles ici
steelseries.com

MICROPHONE

Microphone rétractable

Positionnement

Placez le microphone près du coin de votre bouche, la surface plate vous faisant face

Vue du haut

Vue avant

SERRE-TÊTE DE MASQUE DE SKI

Velcro

Serrez ou desserrez les lanières en Velcro sur les côtés du serre-tête pour un confort optimal.

Instalación

Instruction de l'installation du serre-tête.

Plus de serre-têtes ici steelseries.com

ITALIANO

CONTENUTI DELLA CONFEZIONE

Guida informazioni sul prodotto

Cuffie

Cavo principale

COMPATIBILITÀ DI SISTEMA

PS4 / Xbox One / Switch / VR

Solicite ayuda en support.steelseries.com

GENERALITÀ SUL PRODOTTO

- 01 Archetto stile occhiali da sci*
- 02 Cavo cuffia principale*
- 03 Cuscinetti Airweave*
- 04 Microfono retrattile
- 05 Pulsante microfono muto
- 06 Controllo del volume
- 07 Jack cavo principale
- 08 Splitter per cuffie

* Accessori selezionati disponibili su steelseries.com

MICROFONO

Microfono retrattile

Posizionamento

Sistema il microfono vicino all'angolo della bocca con la superficie piatta rivolta verso di te

Vista dall'alto

Vista frontale

ARCHETTO STILE OCCHIALI DA SCI

Velcro

Stringi o allenta le cinghie di velcro ai lati dell'archetto per ottenere la misura desiderata

Montaggio

Senso di montaggio dell'archetto.

Più fasce qui steelseries.com

PORTUGUÊS

CONTEÚDO DO PACOTE

Guia de informação de produto

Headset

Cabo principal

COMPATIBILIDADE DO SISTEMA

PS4 / Xbox One / Switch / VR

encontre ajuda em support.steelseries.com

VISÃO GERAL DO PRODUTO

- 01 Faixa de óculos de esqui*
- 02 Cabo principal do headset*
- 03 Almofada de orelha Airweave*
- 04 Microfone retrátil
- 05 Botão de silenciar microfone
- 06 Controle de volume
- 07 Entrada do cabo principal
- 08 Entrada de compartilhar fone

* acessórios selecionados disponíveis em steelseries.com

MICROFONE

Microfone retrátil

Posicionamento

Posicione o microfone perto do canto da sua boca com a superfície lisa virada para você

Visão de cima

Visão frontal

FAIXA DE ÓCULOS DE ESQUI

Velcro

Aperte ou afrouxe as tiras de velcro nos lados da faixa para chegar no ponto desejado

Instalação

Direção da instalação da faixa.

mais faixas em steelseries.com

REGULATORY



Class B Product: This device complies with Part 15 of the FCC Rules. Operation is subject to the following two conditions:

1. This device may not cause harmful interference.
2. This device must accept any interference received, including interference that may cause undesired operation.

Attention: Any modifications or changes made to this device that are not approved by Steelseries may void the authority granted to the user by the FCC to operate this equipment.

Note: This equipment has been tested and found to comply with the limits for a Class B digital device, pursuant to Part 15 of the FCC Rules. These limits are designed to provide reasonable protection against harmful interference in a residential installation. This equipment generates, uses and can radiate radio frequency energy and, if not installed and used in accordance with the instructions, may cause harmful interference to radio communications. However, there is no guarantee that interference will not occur in a particular installation. If this equipment does cause harmful interference to radio or television reception, which can be determined by turning the equipment off and on, the user is encouraged to try to correct the interference by one or more of the following measures:

- Reorient or relocate the receiving antenna.
- Increase the separation between the equipment and receiver.
- Connect the equipment into an outlet on a circuit different from that to which the receiver is connected.
- Consult the dealer or an experienced radio/television technician for help.



This product must not be disposed of with your other household waste. For more information about where you can drop off your waste equipment for recycling, please contact your local city office, your household waste disposal service or the shop where you purchased the product.

This product is compliant with requirements of Circular No. 30/2011/TT-BCT Regulations "STIPULATING TEMPORARILY THE PERMISSIBLE CONTENT LIMITATION OF SOME TOXIC CHEMICALS IN THE ELECTRONIC, ELECTRICAL PRODUCTS"

Türkiye Cumhuriyeti: EEE Yönetmeliğine Uygundur

Restriction on Hazardous Substances statement (India)

This product complies with the "India E-waste Rule 2011" and prohibits use of lead, mercury, hexavalent chromium, polybrominated biphenyls or polybrominated diphenyl ethers in concentrations exceeding 0.1 weight % and 0.01 weight % for cadmium, except for the exemptions set in Schedule 2 of the Rule.



クラス B VCCI の表示があるワークステーションおよびオプション製品は、クラス B 情報技術装置です。これらの製品には、下記の項目が該当します。

この装置は、情報処理装置等電波障害自主規制協議会(VCCI)の基準に基づくクラス B 情報技術装置です。この装置、家庭環境で使用することを目的としていますが、この装置がラジオやテレビジョン受信機に近接して使用されると、受信障害を引き起こすことがあります。取扱説明書に従って正しい取り扱いをしてください。VCCI-B

《废弃电器电子产品回收处理管理条例》

为了更好地关爱及保护地球,当用户不再需要此产品或产品寿命终止时,请遵守国家废弃电器电子产品回收处理相关法律法规,将其交给当地具有国家认可的回收处理资质的厂商进行回收处理。

根据中国大陆《电子电气产品有害物质限制使用标识要求》，以下部分列出了产品中可能包含的有害物质的名称和含量：

零部件名称	有害物质					
	铅 (Pb)	汞 (Hg)	镉 (Cd)	六价铬 (Cr+6)	多溴联苯 (PBB)	多溴二苯醚 (PBDE)
塑料	○	○	○	○	○	○
电路板组件	×	○	○	○	○	○
其他线材	×	○	○	○	○	○

*: 电路板组件包括印刷电路板及其构成的零部件, 如电阻、电容、集成电路、连接器等。

本表格依据SJ/T 11364的规定编制。

○: 表示该有害物质在该部件所有均质材料中的含量均在 GB/T 26572规定的限量要求以下。

×: 表示该有害物质至少在该部件的某一均质材料中的含量超出GB/T 26572规定的限量要求；

上表中打“X”的部件, 应功能需要, 部分有害物质含量超出GB/T 26572规定的限量要求, 但是符合欧盟RoHS法规要求(属于豁免部分)。

Coarse Classifier	Chemical Substance Table					
	Pb	Hg	Cd	Cr+6	PBB	PBDE
Plastic	O	O	O	O	O	O
PCBA	Exempted	O	O	O	O	O
Cable	Exempted	O	O	O	O	O
<p>*PCBA consisted of bare printed circuit board, soldering and its surface-mounted elements, such as resistors, capacitors, arrays, connectors, chips, etc.</p> <p>NOTE 1: The "O" indicates that the percentage content of the substance to be calculated is not exceeding the reference percentage content.</p> <p>NOTE 2: The "Exempted" item means that the specified chemical substance corresponds to the items exempted by the standard of JIS C 0950.</p>						

This class B digital apparatus complies with Candian ICES-003
Cet appareil numérique de la classe B est conforme à la norme NMB-003 du Canada



该电子电气产品含有某些有害物质，在环保使用期限内可以放心使用，
超过环保使用期限之后则应该进入回收循环系统。



이 기기는 가정용(8급) 전자파적합기기로서 주로 가정에서 사용하는 것을 목적으로 하여, 모든
지역에서 사용할 수 있습니다



Custom Union Compliance.
(Russia / Belarus / Kazakhstan)



BSMI Compliance. (Taiwan)



FCC Compliance. (USA)



ACMA Compliance (Australia/ New-Zealand)



Direct Current



EMC Directives 2014/30/EU and Low
Voltage Directives 2014/35/EU
Compliance. (European Commission)



To prevent possible hearing damage,
do not listen at high volume levels
for long periods.



Regions	Contact Information	
Asia 亞洲	16F, No.150, Jian-Yi Rd., Chung-Ho Dist, New Taipei City, Taiwan, R.O.C.(235) 丹麥商賽睿有限公司 新北市中和區建一路150號16樓	+886 2 8226 3858
USA	656 W Randolph St, Suite 3E Chicago, IL 60661, USA	+1 312 258 9467
Europe	Dirch Passers Allé 27, 5.Sal 2000 Frederiksberg, Denmark	+45 702 500 75

More information and support at steelseries.com

Product Name (產品名稱/产品名称): Headset (耳機/耳机)

Model No. (型號/型号): HS-00010

Made in China 中國製造/中国制造

Environmental conditions for transport and storage:

Temperature: -20°-- +60°

Humidity: 0%–90% RH

Altitude: 0–3000 m



learn more at steelseries.com