

BUSH

Instruction manual

BCH60B
BCH60SS





You'll soon be enjoying your new Cooker Hood

It all begins here, with your instructions. Don't worry, there's nothing too technical coming up. Just simple, step-by-step guidance to get you up and running quickly. Sound good? Then let's get started.

Help and Guidance

We're here to help you get the most from your Cooker Hood. Should you require any guidance, a simple solution can often be found online at:

www.bush-support.com

If you still require further assistance, call one of our experts on **01759 487838**.

Contents

1	Safety information		
	Safety information	6	
2	Getting to know your Cooker Hood		
	Ready? Let's begin	8	
	Overview	9	
3	Installing your Cooker Hood		
	Installation requirements	12	
	Unpacking	12	
	Mounting Instructions	13	
	Attaching and Aligning Hood	14	
	Fixing Telescopic Flue	15	
4	Using your Cooker Hood		
	Use and Maintenance	18	
	How to Replace Charcoal Filters	19	
	Cooker Hood Control Panel	19	
5	Care and Maintenance		
	Cleaning		22
	Replacing Lamps		22
	Technical specifications		23
6	Product support		
	Troubleshooting		26
	Help and assistance		27
	Declaration of conformance to product standards		28
	Disposal		28
	Guarantee		29

Safety information 1





Safety information

Important - Please read these instructions fully before installing or operating

INSTALLATION WARNINGS

IMPORTANT: This product **MUST** be installed by a qualified installer in accordance with local regulations.

IMPORTANT: Prior to Installation ensure that the local supply conditions (electricity voltage and frequency) are compatible with the requirements of your cooker hood.

IMPORTANT: Carefully unpack and examine the appliance for any damage. If you think there is a defect, do not use the appliance and contact Bush Product Support on 01759 487838. Packaging materials should be collected together and disposed of immediately as they may be harmful to children.

IMPORTANT: Ensure that the electric supply cable is not trapped or damaged during installation.

IMPORTANT: Protect your cooker hood against atmospheric effects. Do not expose your cooker hood to effects such as sun, rain, snow etc.

WARNING: The cooker hood must be mounted on the wall in accordance with the dimensions specified in the mounting diagrams.

DURING USAGE

IMPORTANT: Always replace the aluminium filter of the range hood with an original spare part otherwise the suction power may be reduced in addition to the reduction of service life.

WARNING: The LED lamps become hot during use, do not touch the surface

WARNING: Disconnect the mains power before changing bulbs.

CAUTION: This cooker hood must be kept clean, oil or residue build up could be a fire hazard

Getting to know your Cooker Hood

2



Getting to know your Cooker Hood

You'll be up and running in no time

Ready? Let's begin...

Please read these instructions carefully. They contain important information which will help you get the best from your Cooker Hood and ensure safe and correct installation and operation.

If you require any further assistance, our technical experts are happy to help. For full details, refer to the product support section at the end of these instructions.

If you require any technical guidance or find that your product is not operating as intended, a simple solution can often be found in the **Troubleshooting** section of these instructions.

Getting to know your Cooker Hood

You'll be up and running in no time

Overview



Accessories

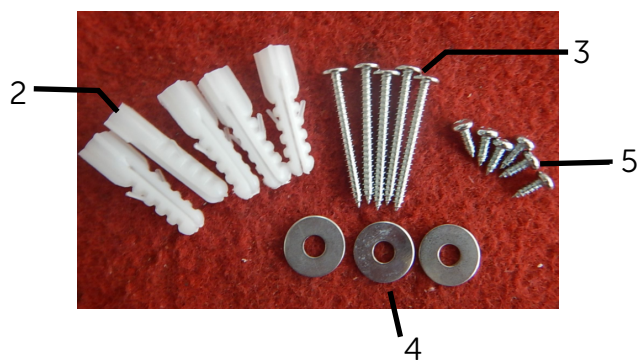

- 1. Fixing knobs
- 2. Wall plugs
- 3. Screws
- 4. Washer
- 5. Screws
- 6. Fixing mount
- 7. Fixing mount

or online at www.bush-support.com. If you still require further assistance, call one of our experts on 01759 487838

Installing your Cooker Hood

3



Installing your Cooker Hood

Bringing it all together

Installation requirements

THIS COOKER HOOD MUST BE INSTALLED BY A COMPETENT PERSON TO LOCAL REGULATIONS

Tools Required for Installation



Electric Drill

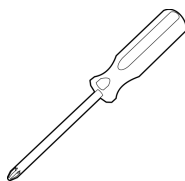

Cross-end Screwdriver

Unpacking

Carefully unpack and examine the appliance for any damage. If you think there is a defect, do not use the appliance and contact Product Support on 01759 487838.

Packaging materials should be collected together and disposed of immediately as they may be harmful to children.

PLEASE NOTE: The cooker hood must be installed at a minimum of 65cm above the hob

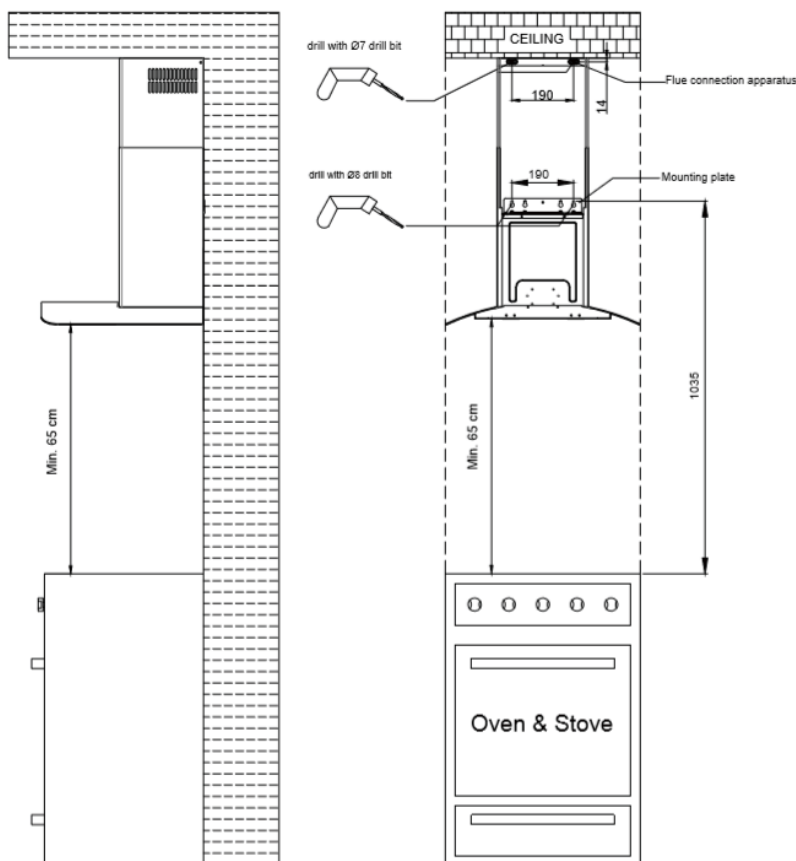

If you require any technical guidance or find that your product is not operating as intended, a simple solution can often be found in the **Troubleshooting** section of these instructions.

Installing your Cooker Hood

Bringing it all together

Mounting Instructions

Preparing the installation Caution!

Ensure that there are no electric wires, gas or water pipes in the area where holes are to be made.

- Mark a vertical centre line on the wall from the ceiling to the lower edge of the extractor hood.
- Mark positions for the screws and the contour of the attachment
- Drill five 8 mm diameter holes to a depth of 50 mm for the attachments and press in the wall plugs flush with the wall.

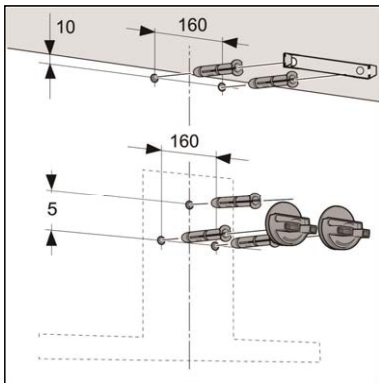

Installation

- Screw on the fixing bracket for the flue duct.

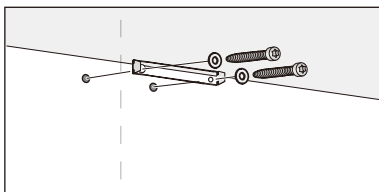

- Screw on brackets for the extractor hood hand-tight. Do not firmly tighten the screws.

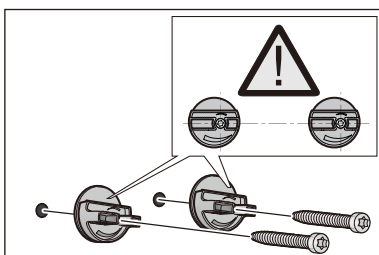

Installing your Cooker Hood

Bringing it all together

Attaching and aligning the appliance

- First, remove the mounting bracket, screw on the machine.

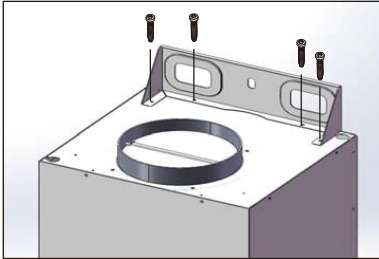

- When attaching the appliance, ensure that it engages firmly with the brackets.
- Align the appliance horizontally by turning the brackets. If required, the appliance can be moved to the right or left.

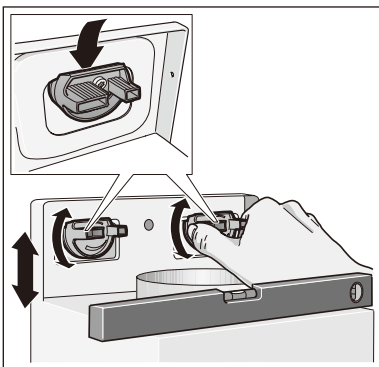

- Firmly tighten the screws for the brackets. When doing so, hold the brackets securely in place.
- Firmly tighten the screws.

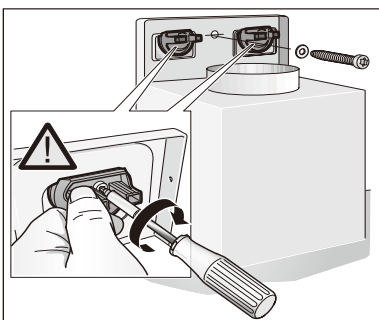

If you require any technical guidance or find that your product is not operating as intended, a simple solution can often be found in the **Troubleshooting** section of these instructions.

Installing your Cooker Hood

Bringing it all together

For the various installations use screws and screw anchors suited to the type of wall (e.g. reinforced concrete, plasterboard, etc.). If the screws and screw anchors are provided with the product, kindly check the screws are suitable for the type of wall in which the hood is to be fixed.

Fixing the Telescopic Flue

Arrange the electrical power supply within the dimensions of the decorative flue. If your appliance is to be installed in the ducting version or in the version with external motor, prepare the air exhaust opening. Adjust the width of the support bracket of the upper flue. Then fix it to the ceiling using the screws make sure that it is in line with your hood and respecting the distance from the ceiling. Connect the flange to the air exhaust hole using a connection pipe.

To transform the hood from a ducting version into a filtering version, ask the product support department for the charcoal filters and please follow the installation instructions.

This cooker hood can be used without access to outside filtration. A charcoal filter (not supplied) can be fitted to recirculate the extraction.

Installing your Cooker Hood

Bringing it all together

Electric Connection

The appliance has been manufactured as Class I, therefore earth cable is necessary

The connection to the mains is carried as follows:

	IEC227
L=live	Brown
N=neutral	Blue
E=earth	Green/Yellow

If the plug is not provided, connect the electrical load as indicated on the description label. When a plug is provided, the cooker hood must be installed in order that the plug is easy to access.

An omni polar switch with minimum aperture of 3mm between contacts; in line with the electrical load and local standards, must be placed between the appliance and the network in the case of direct connection to the electrical network.

The minimum distance between the support surfaces of the cooking pots on the hob top and the lowest part of the cooker hood must be at least 65cm. If a connection tube composed of two parts is used, the upper part must be placed outside the lower part.

Do not connect the cooker hood exhaust to the same conductor used to circulate hot air or for evacuating fumes from other appliances generated by other than an electrical source.

Before proceeding with these assembly operations, remove the anti-grease filter(s) so that the unit is easier to handle.

In the case of assembly the appliance, in the suction version prepare the hole for evacuation of the air.

or online at www.bush-support.com. If you still require further assistance, call one of our experts on 01759 487838

Using your Cooker Hood



Using your Cooker Hood

Getting the most from your appliance

USE AND MAINTENANCE

It is recommended to operate the appliance prior to cooking.

It is recommended to leave the appliance in operation for 15 minutes after cooking is terminated in order to completely eliminate cooking vapors and odours.

The proper function of the cooker hood is conditioned by the regularity of the maintenance operations, in particular, the active charcoal filter.

The anti-grease filters capture the grease particles suspended in the air, and are therefore subject to clogging according to the frequency of the use of the appliance.

In order to prevent fire hazard, it is recommendable to clean the filter at a maximum of 2 months by carrying out the following instructions:

- Remove the filters from the cooker hood and wash them in a solution of water and neutral liquid detergent, leaving to soak.
- Rinse thoroughly with warm water and leave to dry.
- The filters may also be washed in the dishwasher.

Please take note that the aluminum panels may alter in color after several washes.

The active charcoal filters purify the air that is replaced in the environment. The filters are not washable or reusable and must be replaced at maximum every four months. The saturation of the active charcoal filter depends on the frequency of use of the appliance, also by the type of cooking and the regularity of cleaning on the anti-grease filters. To remove the charcoal filters place our hand on one filter at a time and turn it toward the front part. The charcoal filter can now be removed. Always ensure to replace both filters at the same time.

Clean the fan and other surfaces of the cooker hood regularly using a cloth moistened with denatured alcohol or non abrasive liquid detergent.

The illumination installation is designed for use during cooking and not for prolonged general illumination of the environment. Prolonged use of the illumination installation notably reduces the duration of the bulb.

Use a one-edged screwdriver or any other appropriate tool to lift and remove the overhead light fixture. Replace the damaged lamp. Use only halogen lamps as the original specification, avoiding contact with hands. Return the light fixture to its position (snap fastening).

Using your Cooker Hood

Getting the most from your appliance

How to replace the charcoal filters:

The charcoal filters are not supplied with appliance. These can be sourced via the product support helpline.

As indicated in the diagram below, push charcoal filter as shown as arrow B and twist in an anti-clockwise motion to lock in. Twist in a clockwise motion as show as arrow A and pull outwards to remove filter.

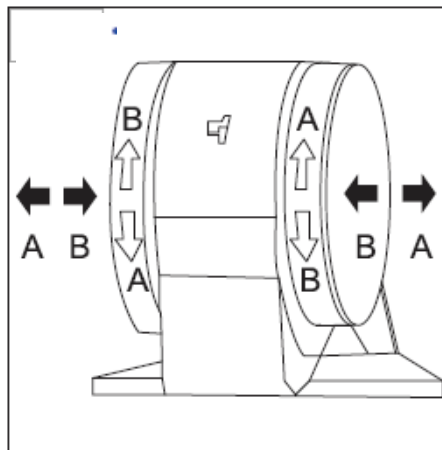

Cooker Hood Control Panel

The cooker hood has a 5 button control panel as shown in the image below.

- Reset button
- Low speed button
- Medium speed button
- High speed button
- Light button



a b c d e

Care and maintenance 5



Care and maintenance

Looking after your appliance

Cleaning

WARNING! Isolate the power supply to the cooker hood before cleaning appliance.

Do not clean using caustic creams, abrasive cleaning powders, thick wire wool or hard tools.

Clean the glass surfaces with special glass cleaning agents.

Never use flammable agents like acid, thinner or petrol when cleaning your cooker hood.

Do not clean your cooker hood with a steam cleaner.

Stainless Steel:

Stainless steel parts must be cleaned frequently with mildly warm soapy water and a soft sponge and then dried with a soft cloth. Do not use abrasive powders or abrasive cleaning materials. Do not leave anything spilled onto stainless steel parts for long periods of time.

Replacing Lamps

To replace the lamps, use a flat ended screwdriver or pallet knife to pop the lamp out carefully. See movable parts in right-hand image For this cooker hood, we use LED lamp, its specification is LED 9P, DC 12V, 2W MAX. If it cannot be found in the local market, please call 01759 487838.

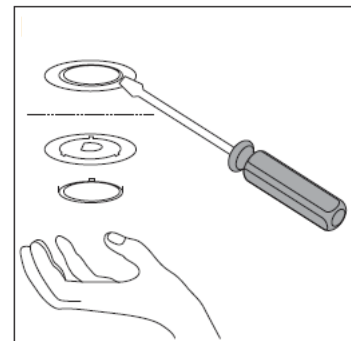

Care and maintenance

Looking after your appliance

Technical specification

Push Button

198W motor

Extraction and Recirculation options

Aluminum Grease Filters

3 fan speed

2 x LED lights

500m³/h Max extraction

Adjustable chimney height range 400-795mm

Product dimensions 640mm-1030mm x 600mm x 480mm (HxWxD)

We apologise for any inconvenience caused by minor inconsistencies within these instructions that may occur due to product improvements and development

All images and drawings are for illustration purposes only.

Product support 6



Product support

Help is always at hand

Troubleshooting

DO NOT ATTEMPT TO REPAIR THIS COOKER HOOD YOURSELF. CALL BUSH PRODUCT SUPPORT ON 01759 487838

Problem	Possible reason	Solution
Hood doesn't work	No electric supply	Check whether the plug is connected
		Check whether the main switch is turned on
Poor airflow	Aluminum grease filters clogged	Clean the filters, assembly back when dry
	Charcoal filters clogged	Replace the charcoal filters
Motor running without air flow	Butterfly valve jammed	Contact technician
After running for a while, motor stop working	High temperature safety device activated	The kitchen is not sufficiently ventilated
	The hood is being installed too near to the cooking stove	The hood must be least 65cm of distance from the stove
Strong cooking smell	Charcoal filters not fitted	In re-circulating mode, charcoal filters must be installed

If you require any technical guidance or find that your product is not operating as intended, a simple solution can often be found in the **Troubleshooting** section of these instructions,

Product support

Help is always at hand

Help and assistance

If you require any technical guidance or find that your Cooker Hood is not operating as intended, a simple solution can often be found in the Troubleshooting section of these instructions or online at www.bush-support.com

If you still require further assistance, call one of our experts on **01759 487838***. To help give us give you a fast and efficient service please have the following information ready:

Model Ref.	<input type="text"/>	You can find these on the rating plate - a small information panel (usually a sticker or metal plate) on the rear of your appliance
Serial number	<input type="text"/>	
Date of purchase	<input type="text"/>	This will be shown on your receipt

Local call rates applies*

Lines open 8am-7pm Monday to Saturday and 10am-4pm Sunday.

*Calls to Bush enquiry lines may attract a charge and set up fee from residential lines depending on your call plan/tariff. Mobile and other providers costs may vary, see www.bt.com/pricing for details.

For Security and training purposes, telephone calls to and from customer service centres maybe recorded and monitored. Calls from Republic of Ireland will attract international call charges.

Product support

Help is always at hand

Declaration of conformance to product standards

This appliance conforms to all relevant standards applicable to domestic appliances sold in the UK

Disposal



This appliance/fitting is marked according to the European directive 2012/19/EU on Waste Electrical and Electronic Equipment (WEEE).

By ensuring this product is disposed of correctly, you will help prevent potential negative consequences for the environment and human health, which could otherwise be caused by inappropriate waste handling of this product.

The symbol on the product, or on the documents accompanying the product, the **crossed out wheellie bin** symbol, indicates that this appliance/fitting may not be treated as household waste. Instead it shall be handed over to the applicable collection point for the recycling of electrical and electronic equipment.

Disposal must be carried out in accordance with local environmental regulations for waste disposal.

For more detailed information about treatment, recovery and recycling of this product, please contact your local authority, your household waste disposal service or the retailer where you purchased the product.



Call us now and activate your 12 month guarantee

Thank you for choosing Bush. Your new product is guaranteed against faults and breakdowns for 12 months. Don't forget to register it with us today so we can provide you with our best possible after-sales service and useful updates.

www.bushregistration.co.uk

FREEPHONE*

0800 597 8548

Lines are open 8am - 8pm, 365 days a year. *Calls may be recorded and monitored.

Your Bush Guarantee

This product is guaranteed for twelve months from the date of original purchase. Any defect that arises due to faulty materials or workmanship will be repaired free of charge (or if applicable the product will be replaced or the purchase price refunded) where possible during this period by the dealer from who your purchased the unit.

The guarantee is subject to the following provisions:

- The guarantee does not cover accidental damage, misuse, cabinet parts, knobs or consumable items.
- The product must be correctly installed and operated in accordance with the instructions contained in the manual.
- It must be used solely for domestic purposes. The guarantee will be rendered invalid if the product is re-sold or has been damaged by inexpert repair.
- Specifications are subject to change without notice.
- Bush disclaim any liability for loss or damage arising from the breakdown of the product.
- This guarantee is in addition to and does not diminish your statutory or legal rights.

Important Data Protection Information

To find out how we and Domestic & General Insurance Plc use your data please refer to the guarantee registration material or visit www.bushregistrations.co.uk

Guarantor: Argos Limited - 489 - 499 Avebury Blvd. - Milton Keynes - MK9 2NW

or online at www.bush-support.com. If you still require further assistance, call one of our experts on **01759 487838**

BUSH



Contact:

www.bush-support.com

Helpline: 01759 487838