

Spike 14in Easy Rider Chopper Kids Bike

Assembly Manual

836/5967
933/9947

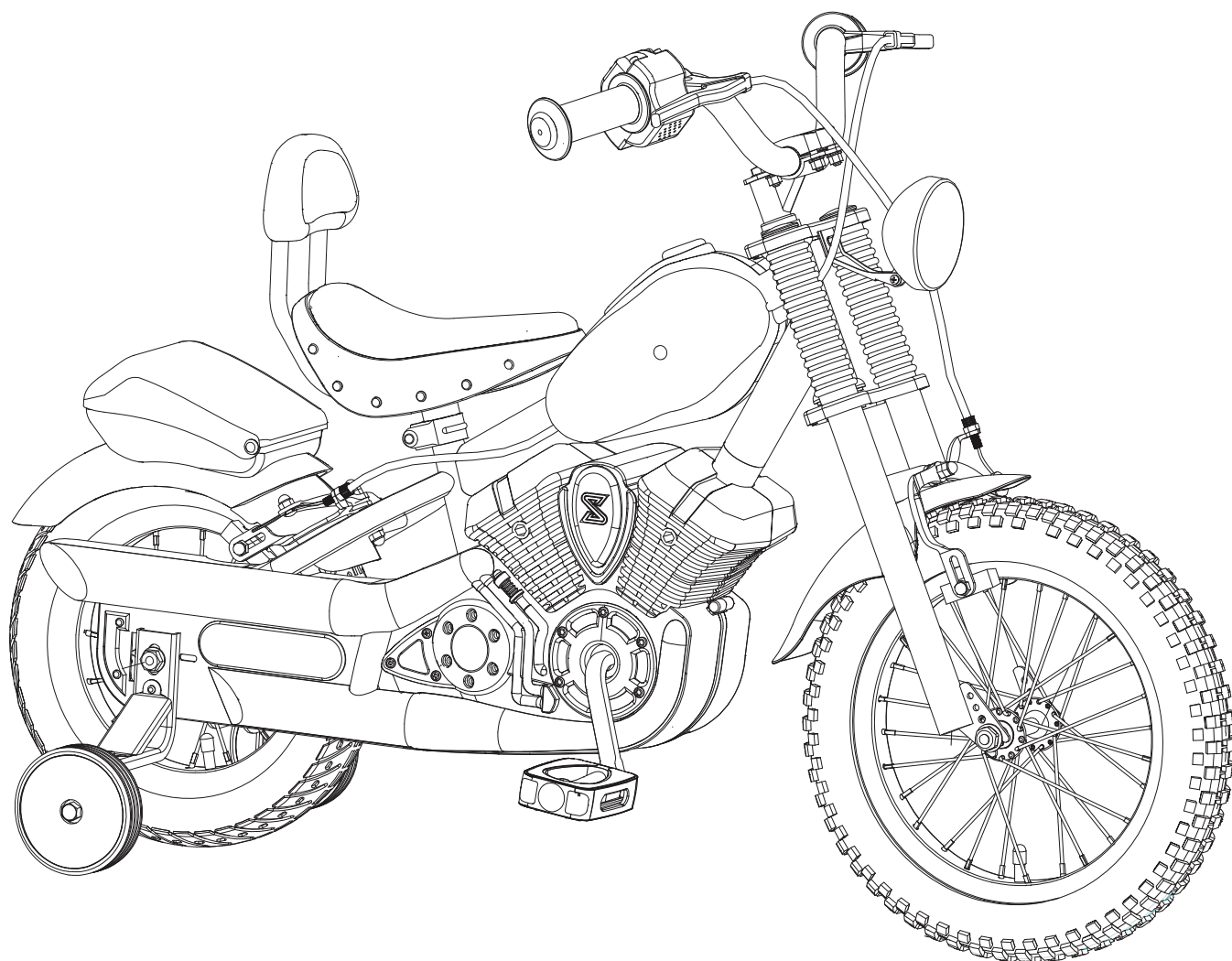

Important - Please read these instructions fully before starting assembly

These instructions contain important information that will help you get the best from your bike. ensuring safe and correct assembly, use and maintenance.

In the Box

Parts

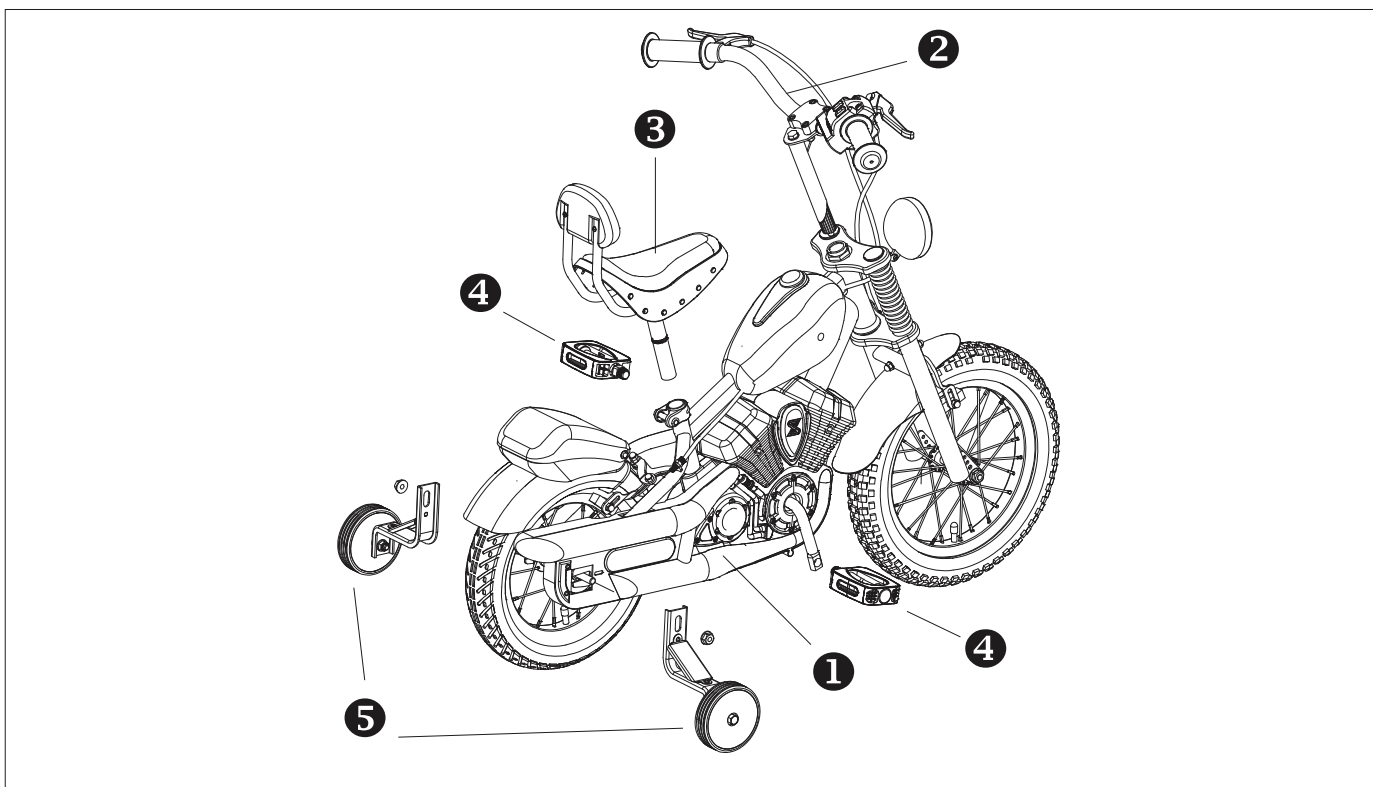

- ① Bike
- ② Handlebar and stem
- ③ Seat post and saddle
- ④ Pedals (supplied in separate box)
- ⑤ Training wheels

Tools

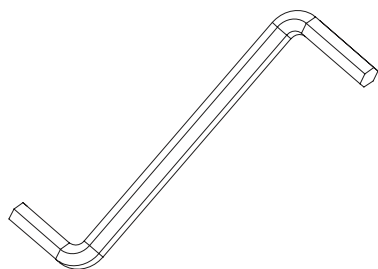

Hexagonal key
(supplied in separate box)

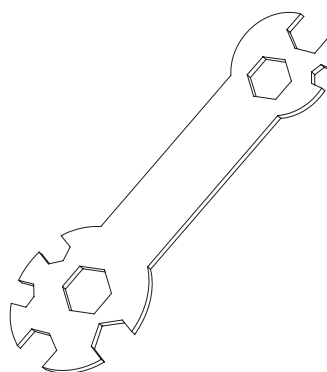

Multitool
(supplied in separate box)

Contents

Assembly	5
Step 1	5
Step 2	6
Step 3	8
Step 4	9
Step 5	10
Riding Advice	11
Before Riding	11
Using the Brakes	11
Using the Horn	12
Riding in Bad Weather	12
Riding in the Dark	12
Riding Using Personal Music Players	12

NEED ANY HELP?

**CUSTOMER
CARE HELPLINE**

01702 208187

support@bspokeleisure.co.uk

**WE CAN GIVE YOU GUIDANCE ON
ASSEMBLY, PARTS & TECHNICAL ADVICE**



Safety Information

Important - Please read these instructions carefully before starting assembly



WARNING! This Bike has been designed, assembled and tested in accordance with the standard BS EN ISO 8098 to ensure your safety. To make sure the bike remains safe. It should only be used for recreational use. Under no circumstances should it be used for competitive cycling, stunting, jumping or acrobatic manoeuvres. These types of cycling may result in serious personal injury and damage to the bike.

WARNING! Always wear a cycle helmet when riding the bike. The helmet should be the correct size for your head and must conform to the European Standard EN1078.

WARNING! When riding in the dark, always make sure that the bike is fitted with suitable reflectors and use a white front light and a red light.

WARNING! Always take extra care when riding in wet, foggy, windy, or icy conditions. The brakes may not be as effective and the braking distances may be increased.

WARNING! Always wear suitable cycling clothing when riding the bike. Loose clothing which may get caught in moving parts should be avoided.

WARNING! This bike is only suitable for use by riders (including any panniers and/or luggage) with a weight of less than 30 kg (66 lb).

WARNING! When assembling the handlebars and stem to the bike frame, make sure the forks are facing in the correct direction. If the forks are assembled correctly, the brakes should be facing forward. Failure to observe the warning may affect their correct operation and may lead to personal injury and damage to the bike.

WARNING! When assembling the seatpost, make sure it is inserted beyond the minimum insert mark. Failure to observe this warning may lead to a potentially unstable seat post and may result in serious personal injury.

WARNING! The front and rear tyres must be fully inflated before attempting to ride the bike. Under no circumstances should the tyres be inflated above the maximum pressure stated on the side of the tyres.

WARNING! Only inflate the front and rear tyres of the bike using a bicycle pump. Do not attempt to use another type of pump to inflate the tyres.

WARNING! As with all mechanical components, the bike is subjected to wear and high stresses. Different materials and components may react to wear, stress or fatigue in different ways. If the design life of a component has been exceeded, it may suddenly fail, possibly causing injuries to the rider. Any form of crack, scratches or change of colouring in highly stressed areas indicate that the life of the component has been reached and it should be replaced.

WARNING! Ensure only genuine replacement parts are used, especially for safety critical parts.

WARNING! The bicycle is not suitable for the fitting of a luggage carrier and a child seat. This bicycle is not designed for public roads use.

WARNING! To avoid injury, please do not sit on front oil tank and rear box.



Safety Information

Important - Please read these instructions carefully before starting assembly



CAUTION! Only use suitable tools to assembled the bike. The use of unsuitable tools may lead to personal injury and damage to the bike.

CAUTION! Always ensure all packaging is removed from the bike before assembly and use. Failure to remove the packaging may prevent the correct operation and may lead to personal injury and damage to the bike.

CAUTION! The safety and smooth running of the bike can only be preserved with regular maintenance. Always ensure the bike is maintained in accordance with the supplied maintenance manual.

CAUTION! Before attaching the handlebar assembly, make sure all cables are free to move and are not tangled. Failure to observe this caution may prevent correct operation and may lead to personal injury and damage to the bike.



IMPORTANT! Before assembling the bike, check all the parts idicated in the manual are in the box. Inspect the parts for signs of damage. Do not assemble the bike if you observe any damaged components.

IMPORTANT! Always take care when removing the packaging to prevent damage to the bike.

IMPORTANT! It is the responsibility of parents or guardians to ensure the safety of this bicycle including when used. Please explain to your child clearly and in detail all operations necessary to ensure safe use of this bicycle,ensure your child understands and can operate the hand brakes, especially a back-pedal brake.



NOTE! Always take recycle the packaging in accordance with local recycling schemes.

NOTE! The pedals and crank arms have colour coded stickers to indicate which pedal matches which Crank Arm.

NOTE! The threads on the left and right pedals are different .To prevent damage to the threads, only tighten the pedals in the direction indicated on the stickers and marked on the end of pedals.

NOTE! The tires may have a direction of rotation arrow embossed on the side of the tire. When the front wheel is assembled, the arrow should be pointing in the direction that the wheel will rotate.

NOTE! Please be aware of the specific risk of entrapment during normal use and maintenance on the front/rear wheel, chain and sprocket.

Recommended Tightening Information

While assembling the bike, it is recomended that, where possible, a torque wrench is used to tighten nuts and bolts. The table below provides a list of torque setting for the various nuts and bolts.

Part	Torque(Nm)
Stem bolt	17-19 Nm
Handlebar clamp nut	17-19 Nm
Seat post bolt	16-18 Nm
Saddle clamp nuts	16-18 Nm
Pedals	40 Nm
Front wheel nuts	22-25 Nm
Rear wheel nuts	25-29 Nm
Cable pinch bolt	6-8 Nm

Assembly

Step 1



IMPORTANT! Before assembling the bike, check all the parts indicated in the manual are in the box. Inspect the parts for sign of damage. Do not assemble the bike if you observe any damage components.

IMPORTANT! Always take care when removing the packaging to prevent damage to the bike.

1. Remove the bike from the box and carefully remove all packaging. The following types of packaging are used to protect the bike during transit:
 - Cardboard Wrapping · This is used to protect the painted surfaces of the bike frame.
 - Cable Ties · These are used to secure loose parts to the partially assembled bike.
 - Stem Caps · These are placed in unprotected ends of the bike frame.
 - Axle Protectors · These are used to protect the outer edges of the front and rear wheel axles.
 - Fork Protectors · These are used to prevent the forks from bending or being damage.
 - Handlebar Stem Protector · This is used ensure the wedge nut remains in the correct orientation during transit.
2. The Packaging should be retained until the bike is fully assembled. Use the box to store the packaging during assembly.



NOTE! Always recycle the packaging in accordance with local recycling schemes.

Assembly

Step 2

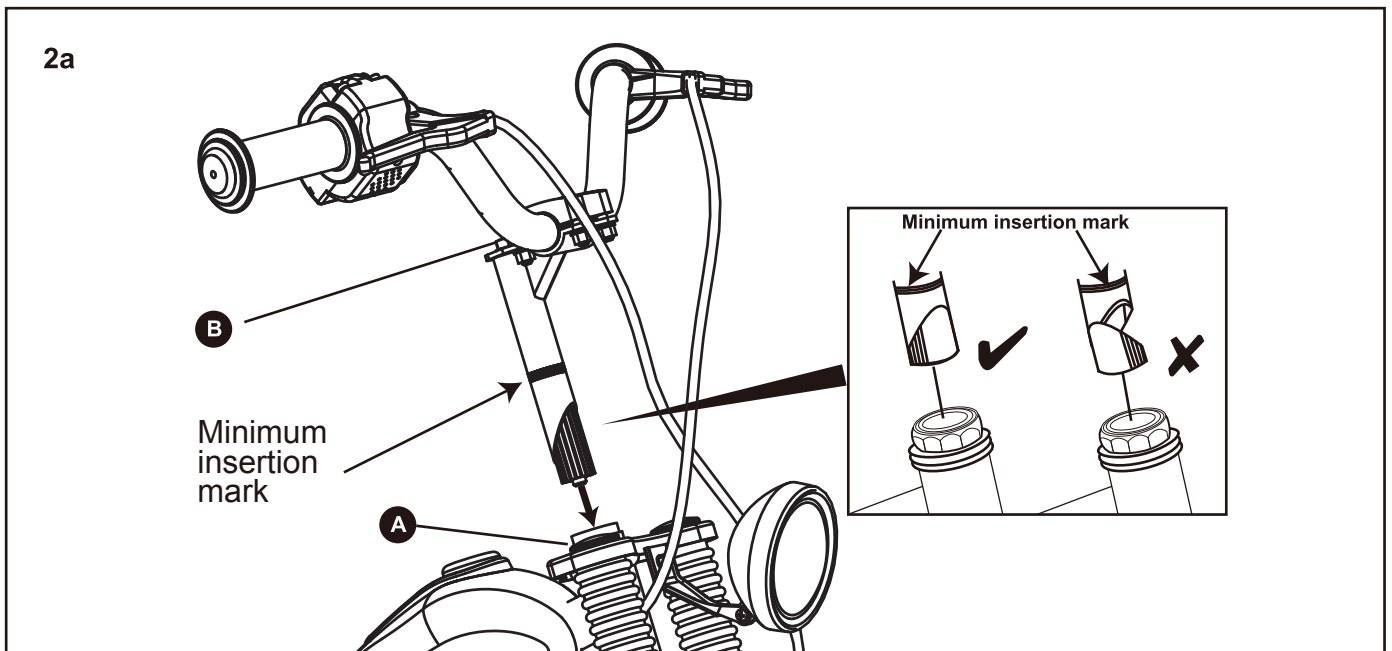

2a Insert the Stem



WARNING! When assembling the handlebars and stem, make sure it is inserted beyond the **minimum insert mark**. Failure to observe this warning may lead to a potentially unstable bike and may result in serious personal injury.

If necessary loosen the stem bolt at the top of the handlebars and stem **B** to allow the wedge nut to move freely.

Ensuring the wedge nut is correctly aligned, insert the lower end of the handlebars and stem **B** into the head tube of the bike **A**.

Assembly

Step 2 (continued)

2b

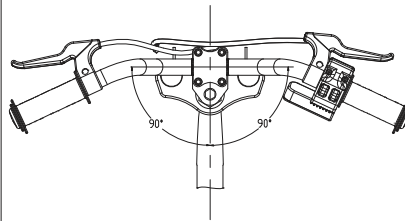
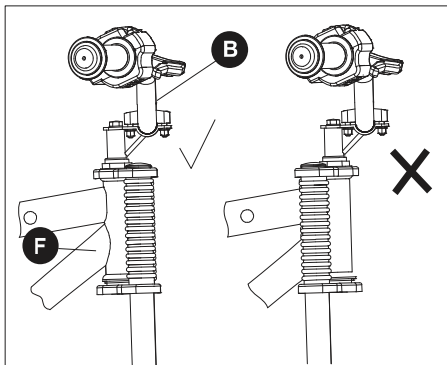

2c

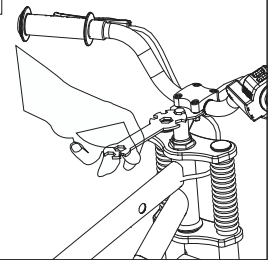
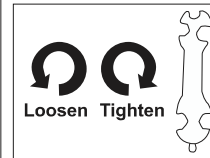

2b Align the Stem



WARNING! When assembling the handlebars and stem to the bike frame make sure the forks are facing in the correct direction. If the forks are assembled correctly, the front brake should be facing forwards. Failure to observe this warning may prevent their correct operation and may lead to personal injury and damage to the bike.

Adjust the handlebars and stem **B** to the desired height and align with the forks **F**. The forks must be facing in the right direction as shown.

2c Securing the stem

The 4 stem bolts have been tightened evenly when you got this bike. if needed you can use the supplied allen key to adjust further.

Step 3

3a

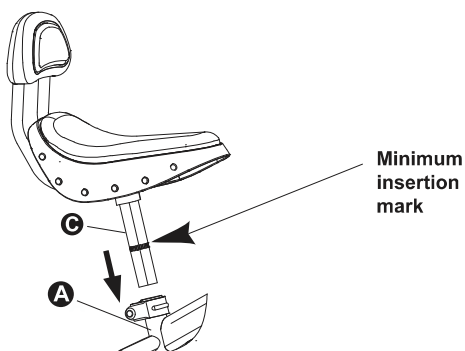

3b

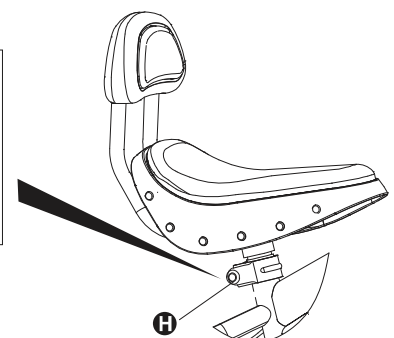
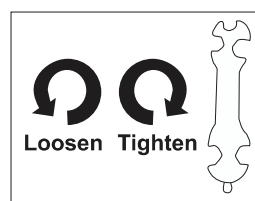

3a Insert the Seat Post and Saddle



WARNING! When assembling the seat post, make sure it is inserted beyond the minimum insert mark. Failure to observe this warning may lead to a potentially unstable seat post may result in serious personal injury.

Insert the lower end of the seat post and saddle **C** into the seat tube of the bike **A**.

3b Securing the Seat Post

Using the supplied spanner wrench tighten the seat post bolt **H** firmly.

Assembly

Step 3 (continued)

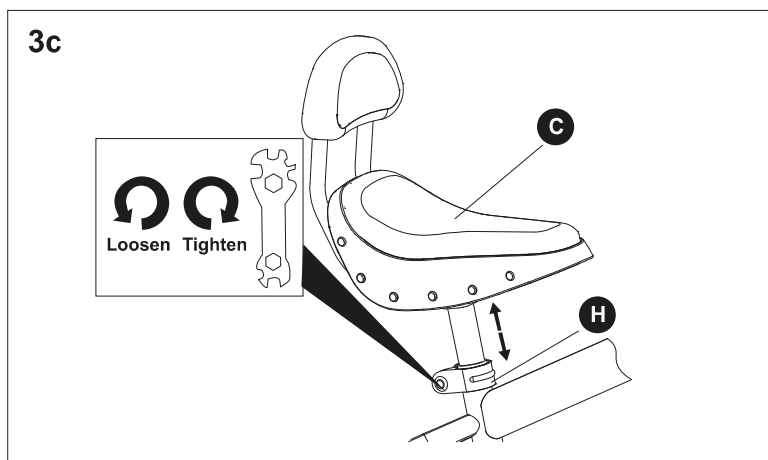

3c Adjusting the Height of the Saddle

The height of the saddle **C** should be adjusted so that the Rider can comfortably touch the ground with both feet. To adjust the height of the saddle **C**, loosen the seat post bolt **H** until the seat post can move freely.

Once the saddle **C** is positioned correctly, retighten the seat post bolt **H**.

WARNING! When assembling the seat post, make sure it is inserted beyond the minimum insert mark. Failure to observe this warning may lead to a potentially unstable seat post and may result in serious personal injury.



WARNING! The saddle height and handlebars are secure, set to a comfortable riding position and do not exceed the minimum insertion mark. The rider when seated should be able to reach the floor with their tip toes and be able to reach the brakes and handlebars without over balancing.

Assembly

Step 4

4a & 4b

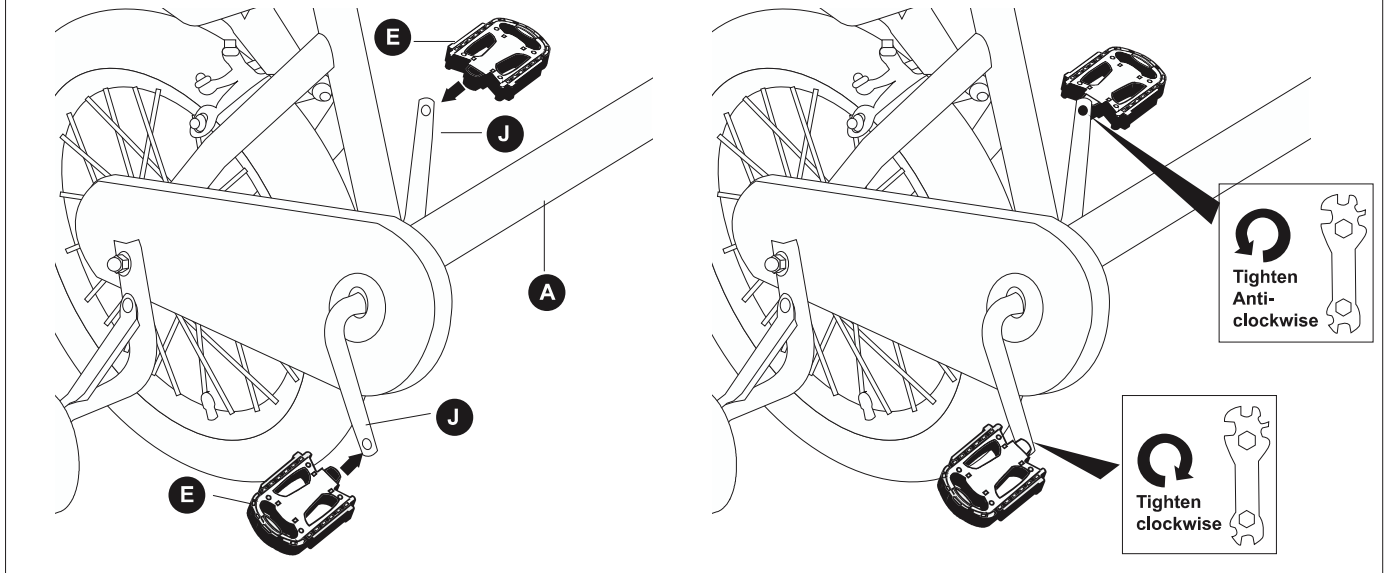

NOTE

The pedals **E** and crank arms **J** have colour coded stickers to indicate which pedal **E** matches which crank arm **J**.

NOTE! The threads on the left and right pedals are different. To prevent damage to the threads, only tighten the pedals in the direction indicated on the stickers and marked on the end of pedals.

4a Fitting the Right Hand Pedal

Locate the right hand pedal **E**. This will have a blue sticker attached.

Locate the right hand crank arm **J** on the bike **A**. This will also have a blue sticker attached.

Insert the threaded shaft to the right hand pedal **E** in to the threaded hole of the right hand crank arm **J**. Initially tighten the pedal using only your fingers in the direction indicated on the colour coded stickers. Fully tighten using multitool supplied.

4b Fitting the Left Hand Pedal

Locate the left hand pedal **E**. This will have a red sticker attached.

Locate the left hand crank arm **J** on the bike **A**. This will also have a red sticker attached.

Insert the threaded shaft to the left hand pedal **E** into the threaded hole of the left hand crank arm **J**. Initially tighten the pedal using only your fingers in the direction indicated on the colour coded stickers. Fully tighten using multitool supplied.

Assembly

Step 5

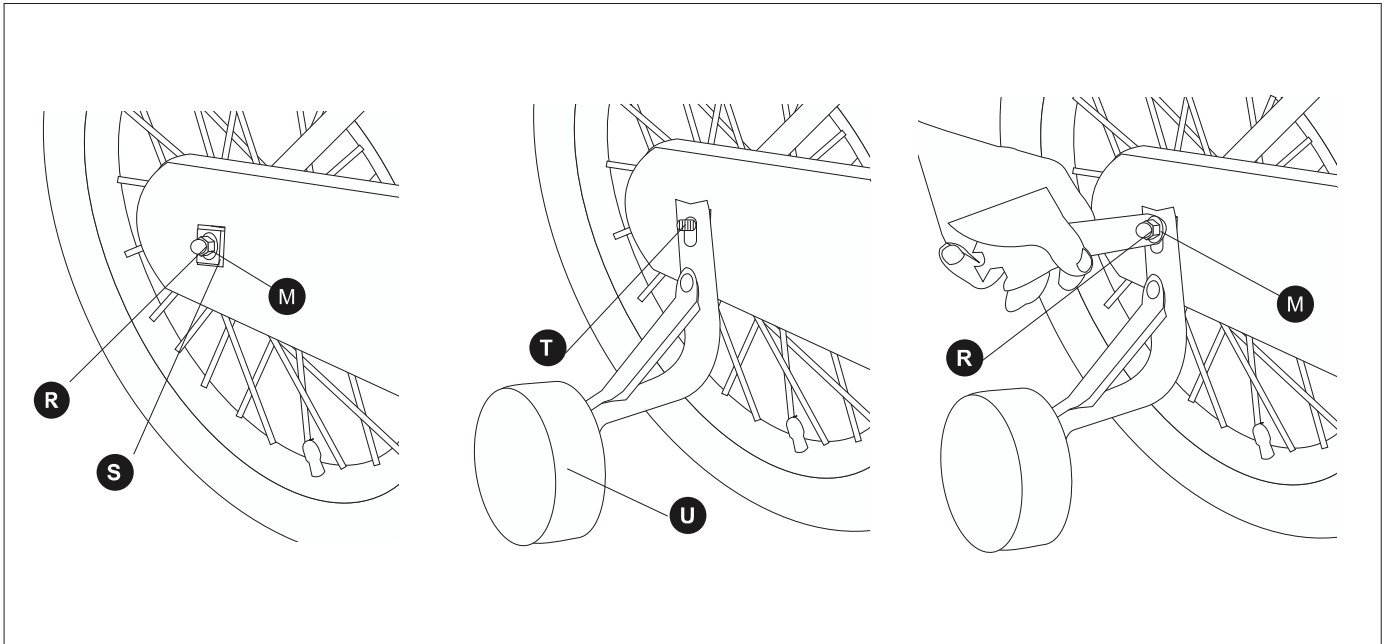

Fitting The Stabilisers

Remove the outer nuts **R** from the ends of the rear axle **T**

Fit one stabiliser on each side of the rear axle **T**. Ensure that the stabiliser **U** fits snugly over the tabbed washer **S**.

Refit the outer nuts **R** with **S** and **M** washers and tighten using the multi-tool provided with the bike.

Check that the stabiliser **U** wheels are positioned very slightly above the ground when the bike is standing upright. They should stop the bike from falling. Reposition them if necessary.

Riding Advice

Before Riding

You should perform the following checks before riding your bike to ensure it is safe to use and operating correctly.

1. Is the saddle Secure?

While standing next to the bike, try and move the saddle from side to side. If the saddle moves you should retighten the seat post bolt or the saddle clamp bolts.

2. Are the Front and Rear Tyres Inflated Correctly?

Squeeze the sides of the front and rear tyres. If they are soft they will need inflating. Re - inflate to the pressure indicated on the sides of the tyres using approved bicycle pump.

3. Are the Pedals Tight?

Using the supplied multitool, ensure both the left and right pedals are fully tight. Remember that the threaded shafts of the left and right pedals tighten in different directions.

4. Do the Brakes Work?

Stand next to the bike and apply the front brake and push forwards. If the wheels move, the front brake may not be working correctly. If required, adjust the front brakes as described in the Maintenance Manual.

Repeat the above check for the rear brake.

5. Do the Handlebars Move?

Hold the front wheel between your legs and try to move the handlebars . If the handlebars move, the stem bolt may have become loose. Retighten the stem bolt.

6. Is the bike Clean?

The bike should be cleaned and re-oiled regularly to ensure it operates correctly.

Using the Brakes

The bike is fitted with front and rear brakes to stop the bike effectively.

The brakes are operated using two brake lever mounted on the handle bars . The left hand brake lever operates the rear brake and the right hand brake lever operates the front brake.

Riding Advice

Using the horn

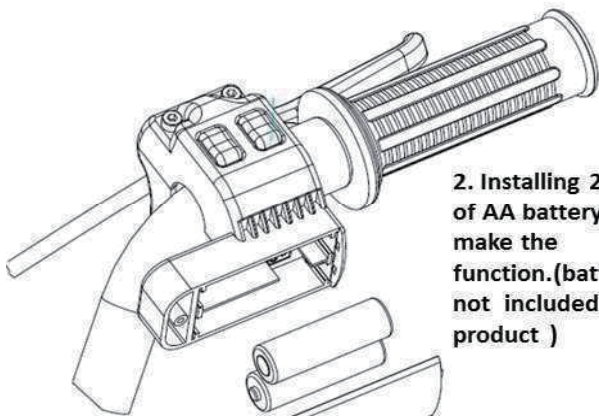

2. Installing 2 pieces of AA battery to make the function.(battery is not included in this product)



Argos Ltd.,
489-499 Avebury Boulevard Central Milton Keynes MK9 2NW
WARNING! NOT SUITABLE FOR CHILDREN UNDER 3 YEARS OLD. CONTENTS SMALL PARTS.

1. Using screw driver to open the battery cap

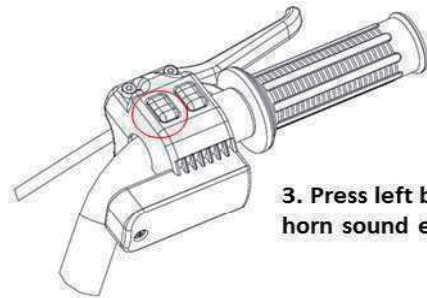

3. Press left button: horn sound effect

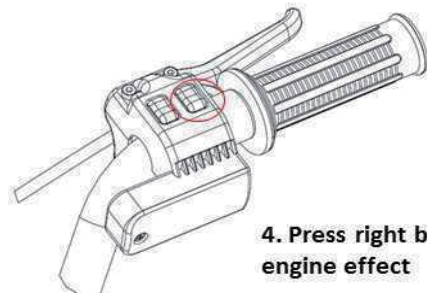

4. Press right button: engine effect

Riding in Bad Weather



WARNING! Always take extra care when riding in wet, foggy, windy or icy conditions. The brakes may not be as effective and the braking distances may be increased.

When riding in bad weather i.e. wet, foggy, windy or icy, always wear bright, reflective clothing which is warm and waterproof.

You should always give other road users clear signals plenty of time particularly when approaching junctions. Always brake earlier than you would in the dry as the required braking distance will be increased.

Be aware that all types of surface become greasy or slippery in bad weather. Do not turn or brake suddenly.

Riding in the Dark



WARNING! When riding in the dark, always make sure that the bike is fitted with suitable reflectors and a white front light and a red rear light.

It is essential that other road users can clearly see you when riding in the dark. Always wear bright, reflective clothing. Suitable reflectors should be fitted to the front and rear of the bike and if possible the wheels. A white light must be fitted to the front of the bike and a red light at the rear.

Clean reflectors regularly and make sure they can be seen from distance.

Riding Using Personal Music Players

It is recommended that personal music players are not used while riding a bike. These devices prevent you from hearing approaching vehicles and may prove to be a distraction.