

User Guide



Lenovo LOQ Tower 17IRR9

Read this first

Before using this documentation and the product it supports, ensure that you read and understand the following:

- *Safety and Warranty Guide*
- [Generic Safety and Compliance Notices](#)
- *Setup Guide*

First Edition (March 2024)

© Copyright Lenovo 2024.

LIMITED AND RESTRICTED RIGHTS NOTICE: If data or software is delivered pursuant to a General Services Administration "GSA" contract, use, reproduction, or disclosure is subject to restrictions set forth in Contract No. GS-35F-05925.

Contents

About this documentationiii	Power cord	12
Chapter 1. Meet your computer.	1	Computer cover.	12
Front	1	Front bezel.	13
Rear	3	Storage drive cage (for selected models)	14
Features and specifications	4	3.5-inch storage drive	15
USB specifications	5	Memory module	17
The Vantage app	5	M.2 solid-state drive and heatsink	19
Chapter 2. Get started with your computer.	7	PCI-Express card and PCI-Express card holder	21
Access networks	7	Power supply assembly.	26
Connect an external display	7	Chapter 4. Help and support	29
Connect to a Bluetooth device	7	Find your serial number.	29
Conventional pair	7	Diagnose and troubleshoot your computer	29
Swift pair	8	Troubleshoot and diagnose at Lenovo	
ICE performance mode	8	Support Web site	30
Set the power plan	8	Hardware scan	30
Security	9	Recover Windows operating system.	30
Lock the computer.	9	Call Lenovo	31
Use software security solutions	9	Before you contact Lenovo	31
Chapter 3. CRU replacement	11	Self-help resources	31
CRU list	11	Purchase accessories or additional services	32
Tool-less storage	11	Appendix A. Notices and trademarks.	33

About this documentation

- This guide applies to the Lenovo product models listed below. Illustrations in this guide may look slightly different from your product model.

Model name	Machine types (MT)
LOQ Tower 17IRR9	90WY, 90X0

- For further compliance information, refer to the Generic Safety and Compliance Notices at https://pcsupport.lenovo.com/docs/generic_notices.
- Depending on the model, some optional accessories, features, and software programs might not be available on your computer.
- Depending on the version of the operating systems and programs, some user interface instructions might not be applicable to your computer.
- Documentation content is subject to change without notice. Lenovo makes constant improvements to the documentation of your computer, including this *User Guide*. To get the latest documentation, go to <https://pcsupport.lenovo.com>.
- Microsoft® makes periodic feature changes to the Windows® operating system through Windows Update. As a result, some information in this documentation might become outdated. Refer to Microsoft resources for the latest information.

Chapter 1. Meet your computer

This computer is equipped with an extensive selection of ports, providing convenient connectivity options for multiple devices.

Front

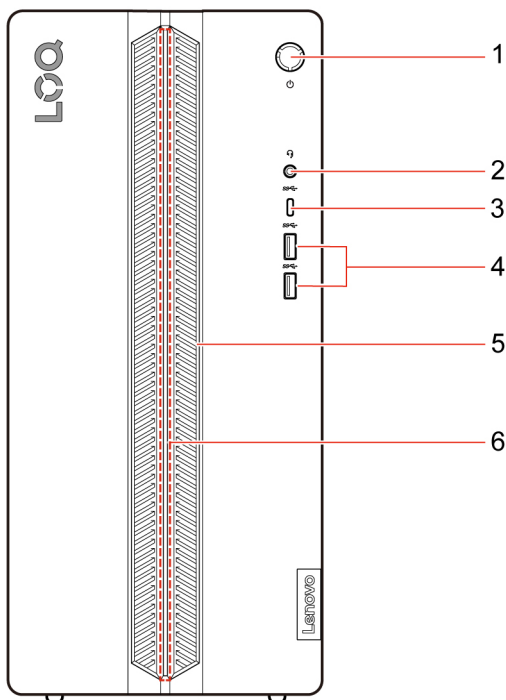

Item	Description	Item	Description
1	Power button	2	Headset connector
3	USB-C® (3.2 Gen 1) connector	4	USB-A 3.2 Gen 1 connectors (2)
5	Ventilation slots	6	LED light bar

Statement on USB transfer rate

Depending on many factors such as the processing capability of the host and peripheral devices, file attributes, and other factors related to system configuration and operating environments, the actual transfer rate using the various USB connectors on this device will vary and will be slower than the data rate listed below for each corresponding device.

USB device	Data rate (Gbit/s)
3.2 Gen 1	5
3.2 Gen 2	10
3.2 Gen 2 × 2	20

USB device	Data rate (Gbit/s)
Thunderbolt™ 3	40
Thunderbolt 4	40

Power indicator

Show the system status of your computer.

- **On:** The computer is starting up or working.
- **Off:** The computer is off or in hibernation mode.
- **Blinking:** The computer is in sleep mode.

LED light bar

The LED light bar on the front bezel has the following lighting behaviors.

Computer status	Lighting behavior
Off	Off
On (Non-sleep mode)	<ul style="list-style-type: none"> • Solid white (Default), or • Blinking white every 4, 6, or 8 seconds
Sleep mode	Blinking white every 8 seconds

The LED light bar also features three levels of brightness.

- High (100%, default)
- Medium (60%)
- Low (30%)

You can change the brightness in Lenovo Vantage or Lenovo PC Manager.

Related topics

- “USB specifications” on page 5.

Rear

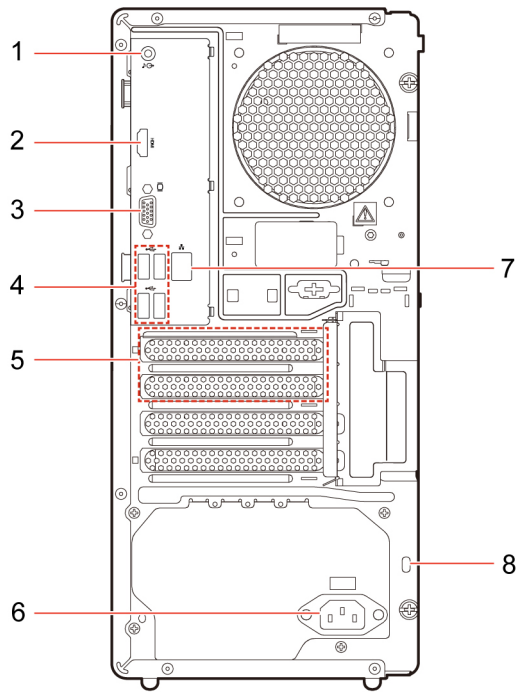

Item	Description	Item	Description
1	Audio line-out connector	2	HDMI™ 2.1 out connector (TMDS)
3	VGA-out connector	4	USB-A 2.0 connectors (4)
5	PCI-Express card area	6	Power cord connector
7	Ethernet connector (1G)	8	Security-lock slot

Related topics

- “Lock the computer” on page 9.
- “Connect an external display” on page 7.
- “USB specifications” on page 5.

Features and specifications

Item	Description
Hardware	To view the hardware information of your computer, type Device Manager in the Windows search box and then press Enter.
Power supply	<ul style="list-style-type: none">• 300-watt automatic voltage-sensing power supply*• 310-watt automatic voltage-sensing power supply*• 380-watt automatic voltage-sensing power supply*• 500-watt automatic voltage-sensing power supply*
Microprocessor	To view the microprocessor information of your computer, type system information in the Windows search box and then press Enter.
Memory	Double data rate 5 (DDR5) dual in-line memory module (DIMM)
Storage device	To view the storage drive capacity of your computer, type Disk Management in the Windows search box and then press Enter. Note: The storage drive capacity indicated by the system is less than the nominal capacity.
Expansion	<ul style="list-style-type: none">• 1 SATA 3.0 port• 2 DDR5 DIMM slots• 2 M.2 PCIe slots (1 for WIFI&BT; 1 for PCIe Gen4 SSD)• 1 3.5-inch hard disk drive bay• 2 PCI Express slots (1 for PCIe Gen4 x 16; 1 for PCIe x 1)
Network features	<ul style="list-style-type: none">• Bluetooth• Ethernet LAN• Wireless LAN

* for selected models

Operating environment

Maximum altitude (without pressurization)

- Operating: From 0 m (0 ft) to 3048 m (10 000 ft)
- Storage: From 0 m (0 ft) to 12192 m (40 000 ft)

Temperature





- Operating: From 5°C (41°F) to 35°C (95°F)
- Storage:
 - For common desktop computers: From -40°C (-40°F) to 60°C (140°F)
 - For all-in-one desktop computers: From -20°C (-4°F) to 60°C (140°F)

Relative humidity

- Operating: 20%-80% (non-condensing)
- Storage: 10%-90% (non-condensing)

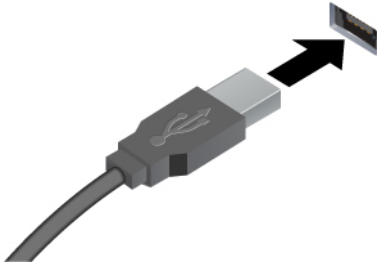
USB specifications

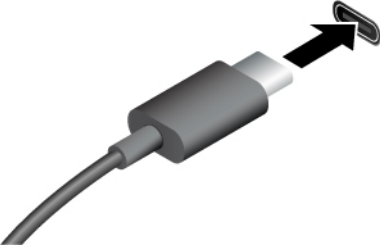
Note: Depending on the model, some USB connectors might not be available on your computer.

Connector name	Description
 <ul style="list-style-type: none">•  USB-A 2.0 connector•  USB-A 3.2 Gen 1 connector	<p>Connect USB-A compatible devices, such as a USB-A keyboard, USB-A mouse, USB-A storage device, or USB-A printer.</p>
 <ul style="list-style-type: none">•  USB-C (3.2 Gen 1) connector	<ul style="list-style-type: none">• Charge USB-C compatible devices with the output voltage and current of 5 V and 3 A.• Connect to USB-C accessories to help expand your computer functionality. To purchase USB-C accessories, go to https://www.lenovo.com/accessories.

The Vantage app

The Vantage app is a customized one-stop solution to help you maintain your computer with automated updates and fixes, configure hardware settings, and get personalized support.

To access the Vantage app, type Vantage in the Windows search box.

Notes:

- The available features vary depending on the computer model.
- The Vantage app makes periodic updates of the features to keep improving your experience with your computer. The description of features might be different from that on your actual user interface. You can download the latest version of Vantage app from Microsoft Store.

The Vantage app enables you to:

- Know the device status easily and customize device settings.
- Download and install UEFI BIOS, firmware, and driver to keep your computer up-to-date.
- Monitor your computer health, and secure your computer against outside threats.
- Scan your computer hardware and diagnose hardware problems.
- Look up warranty status (online).

- Access *User Guide* and helpful articles.

Chapter 2. Get started with your computer

Access networks

This section helps you connect to a wireless or wired network.

Connect to Wi-Fi networks

Click the network icon  on the bottom right of your display to connect to an available network. Provide required information, if needed.

Note: The wireless LAN module on your computer may support different standards. For some countries or regions, use of 802.11ax may be disabled according to local regulations.

Connect to the wired Ethernet

Connect your computer to a local network through the Ethernet connector on your computer with an Ethernet cable.

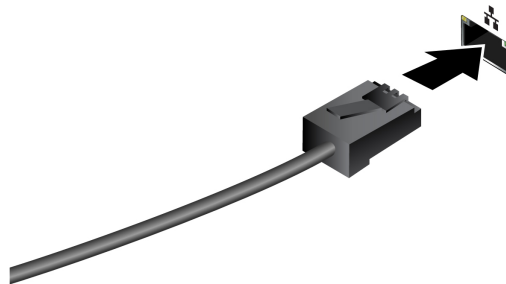

Connect an external display

Connect a projector or a monitor to your computer to give presentations or expand your workspace.

Change display settings

1. Right-click a blank area on the desktop and select display settings.
2. Select the display that you want to configure and change display settings of your preference.

Connect to a Bluetooth device

You can connect all types of Bluetooth-enabled devices to your computer, such as a keyboard, a mouse, a smartphone, or speakers. To ensure successful connection, place the devices at most 10 meters (33 feet) from the computer.

Conventional pair

This topic helps you connect to a Bluetooth device by conventional pair.

- Step 1. Type Bluetooth in the Windows search box and then press Enter.
- Step 2. Turn on both the Bluetooth on your computer and the Bluetooth device. Make sure the device is discoverable.

Step 3. Select the device when it is displayed on the **Add a device** list, and then follow the on-screen instructions.

Notes: If the Bluetooth connection failed, do the following:

1. Type Device Manager in the Windows search box and then press Enter.
2. Locate the Bluetooth adapter. Right-click and select **Update driver**.
3. Select **Search automatically for drivers**, and then follow the on-screen instructions.

Swift pair

This topic helps you connect to a Bluetooth device by swift pair.

If your Bluetooth device supports swift pair, do the following:

- Step 1. Enable swift pair notification on Bluetooth settings page.
- Step 2. Turn on both the Bluetooth on your computer and the Bluetooth device. Make sure the device is discoverable.
- Step 3. Click **Connect** when a swift pair notification appears on your computer.

Notes: If the Bluetooth connection failed, do the following:

1. Type Device Manager in the Windows search box and then press Enter.
2. Locate the Bluetooth adapter. Right-click and select **Update driver**.
3. Select **Search automatically for drivers**, and then follow the on-screen instructions.

ICE performance mode

The ICE performance mode helps you adjust the acoustic and thermal performance of your computer. Three options are available:

- **Balance mode** (default setting): The computer works at the balance mode with balanced noise and better performance.
- **Performance mode:** The computer works at the best performance with normal acoustic level.

Note: The term “best” only refers to the best effect among different settings of the product itself.

- **Full Speed:** All fans in the computer will run at full speed.

Set the power plan

For ENERGY STAR® compliant computers, the following power plan takes effect when your computers have been idle for a specified duration:

- Turn off the display: After 10 minutes
- Put the computer to sleep: After 25 minutes

To awaken the computer from Sleep mode, press any key on your keyboard.

To reset the power plan:

1. Type Power Options in the Windows search box and then press Enter.
2. Choose or customize a power plan of your preference.

Security

This computer offers a wealth of security measures to protect both the device and data safety.

Lock the computer

Note: Lenovo makes no comments, judgments, or warranties about the function, quality, or performance of the locking device and security feature. You can purchase computer locks from Lenovo.

Security lock

Lock your computer to a desk, table, or other fixtures through a security lock.

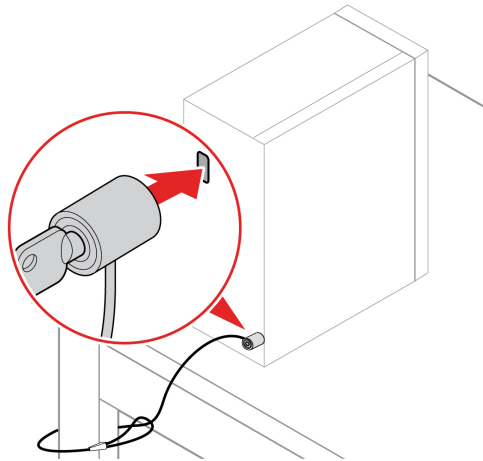

Use software security solutions

The following software solutions help secure your computer and information.

- **Windows Security**

Windows Security is a software built-in to the operating system. It continually scans for malicious software, viruses, and other security threats. Besides, Windows updates are downloaded automatically to help keep your computer safe. Windows Security also enables you to manage tools including firewall, account protection, application and browser control, and so on.

- **Antivirus programs**

Lenovo preinstalls a full-version antivirus software on selected models of computer. It helps defend the computer against viruses, safeguard your identity, and keep your personal information secured.

- **Absolute Persistence**

Absolute Persistence technology is embedded in firmware. It detects changes that happen on the hardware, software, or the call-in location. It keeps you always knowing what condition the computer is in. To activate the technology, you have to purchase a subscription to Absolute.

Note: For more information about how to use these software solutions, refer to their help systems respectively.

Chapter 3. CRU replacement

Customer Replaceable Units (CRUs) are parts that can be replaced by the customer. Lenovo computers contain the following types of CRUs:

- **Self-service CRUs:** Refer to parts that can be replaced easily by customer themselves or by trained service technicians at an additional cost.
- **Optional-service CRUs:** Refer to parts that can be replaced by customers with a greater skill level. Trained service technicians can also provide service to replace the parts under the type of warranty designated for the customer's machine.

If you intend on installing the CRU, Lenovo will ship the CRU to you. CRU information and replacement instructions are shipped with your product and are available from Lenovo at any time upon request. You might be required to return the defective part that is replaced by the CRU. When return is required: (1) return instructions, a prepaid shipping label, and a container will be included with the replacement CRU; and (2) you might be charged for the replacement CRU if Lenovo does not receive the defective CRU within thirty (30) days of your receipt of the replacement CRU. For full details, see the Lenovo Limited Warranty documentation at:

https://www.lenovo.com/warranty/llw_02

CRU list

The following is the CRU list of your computer.

Self-service CRUs

- Power cord
- Computer cover
- Keyboard*
- Mouse*
- Front bezel
- Memory module
- PCI-Express card holder
- Storage drive cage*
- 3.5-inch storage drive
- 3.5-inch storage drive bracket

Optional-service CRUs

- M.2 solid-state drive
- M.2 solid-state drive heatsink
- Power supply assembly
- PCI-Express card

* for selected models

Tool-less storage

You can remove or replace the storage devices of this computer without tools.

Related topics

- “Hard disk drive” on page 15.
- “Memory module” on page 17.

Power cord

Prerequisite

Before you start, read *Generic Safety and Compliance Notices*, and print the following instructions.



Before you remove the power cord, turn off the computer and wait several minutes until the computer is cool.

For access, do the following: Turn off the computer and remove all connected devices and cables.

Removal steps

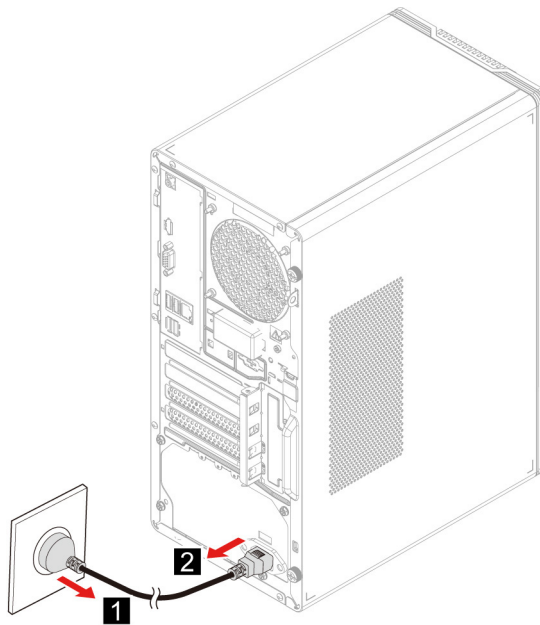

Computer cover

Prerequisite

Before you start, read *Generic Safety and Compliance Notices*, and print the following instructions.



Before you open the computer cover, turn off the computer and wait several minutes until the computer is cool.

For access, do the following:

1. Turn off the computer and remove all connected devices and cables.

2. Unlock any locking device that secures the computer cover. See “Lock the computer” on page 9.
3. Remove the power cord. See “Power cord” on page 12.

Removal steps

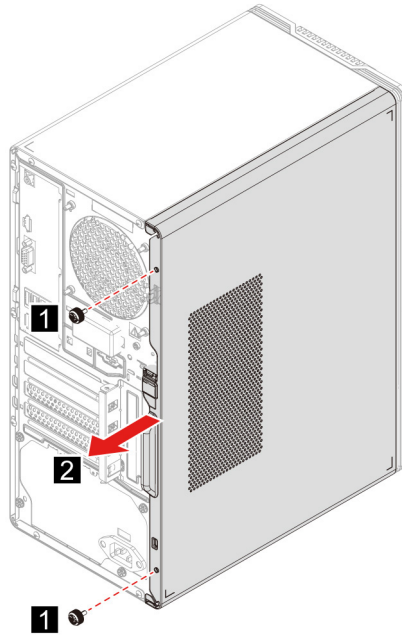

Front bezel

Prerequisite

Before you start, read *Generic Safety and Compliance Notices*, and print the following instructions.



Before you open the computer cover, turn off the computer and wait several minutes until the computer is cool.

For access, do the following:

1. Remove the power cord. See “Power cord” on page 12.
2. Remove the computer cover. See “Computer cover” on page 12.
3. Disconnect the LED cable from the system board.

Removal steps

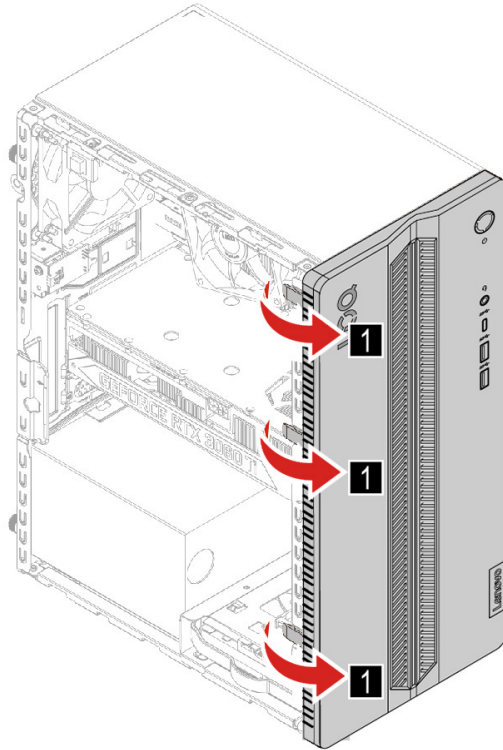

Storage drive cage (for selected models)

Prerequisite

Before you start, read *Generic Safety and Compliance Notices*, and print the following instructions.

For access, do the following:

1. Remove the power cord. See “Power cord” on page 12.
2. Remove the computer cover. See “Computer cover” on page 12.

Removal steps

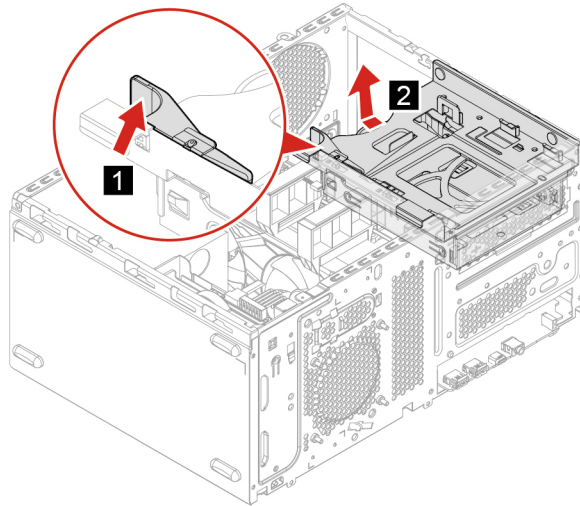

3.5-inch storage drive

Prerequisite

Before you start, read *Generic Safety and Compliance Notices*, and print the following instructions.

Attention: The internal storage drive is sensitive. Inappropriate handling might cause damage and permanent loss of data. When handling the internal storage drive, observe the following guidelines:

- Replace the internal storage drive only for upgrade or repair. The internal storage drive is not designed for frequent changes or replacement.
- Before replacing the internal storage drive, make a backup copy of all the data that you want to keep.
- Do not touch the contact edge of the internal storage drive. Otherwise, the internal storage drive might get damaged.
- Do not apply pressure to the internal storage drive.
- Do not make the internal storage drive subject to physical shocks or vibration. Put the internal storage drive on a soft material, such as cloth, to absorb physical shocks.

For access, do the following:

1. Remove the power cord. See “Power cord” on page 12.
2. Remove the computer cover. See “Computer cover” on page 12.
3. Disconnect the signal cable and the power cable from the storage drive.

Removal steps

- **Type 1**

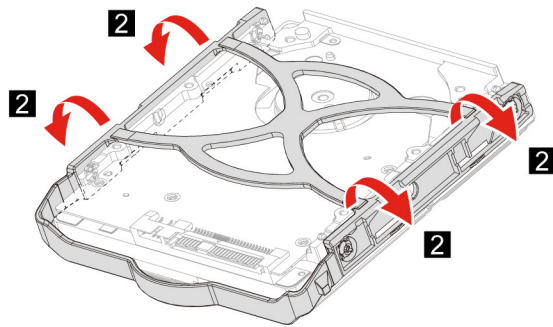
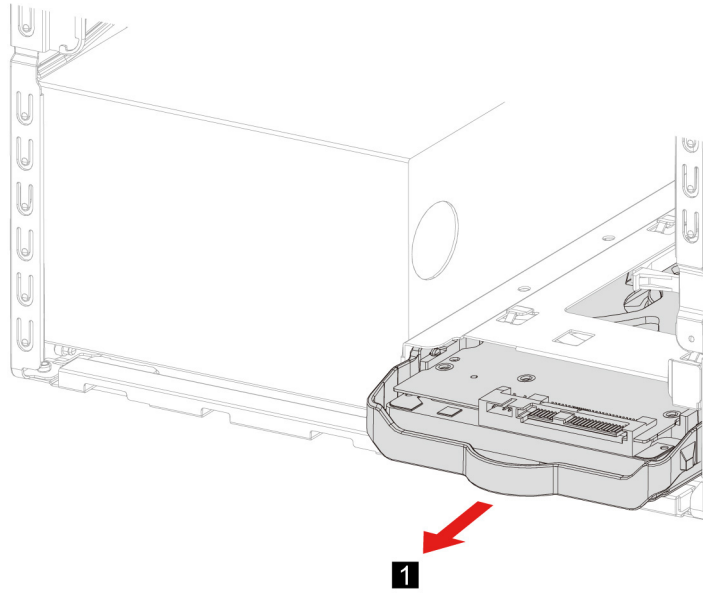

- Type 2

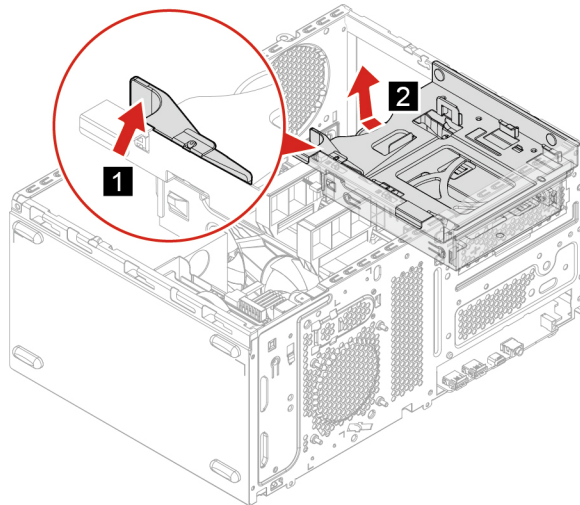

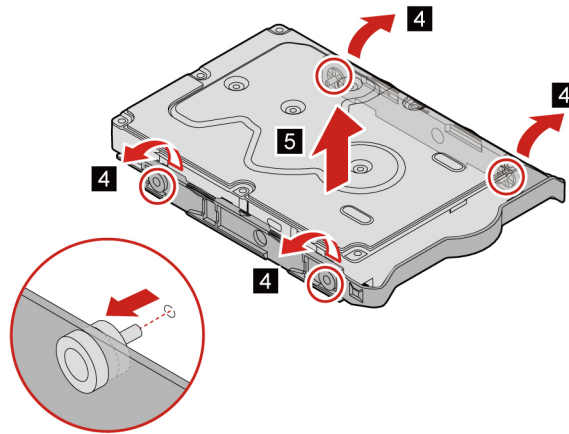
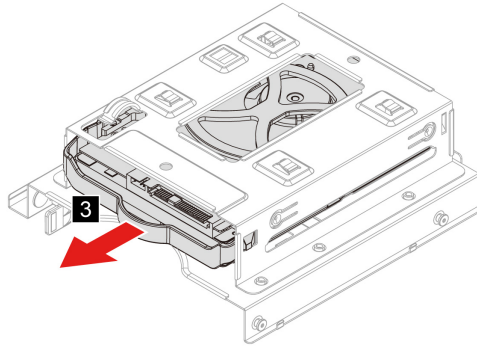

Memory module

Prerequisite

Before you start, read *Generic Safety and Compliance Notices*, and print the following instructions.

For access, do the following:

1. Remove the power cord. See “Power cord” on page 12.
2. Remove the computer cover. See “Computer cover” on page 12.
3. Remove the storage drive cage. See “Storage drive cage” on page 14.

The following illustration shows the location of the memory slots on the system board. Ensure that you follow the installation order for memory modules shown in the following illustration.

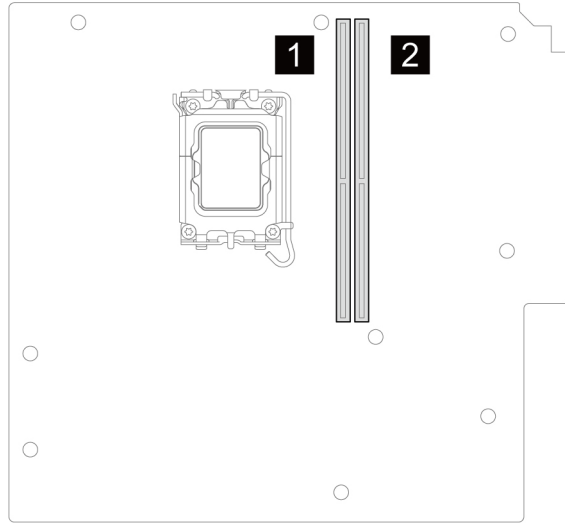

Replacement procedure

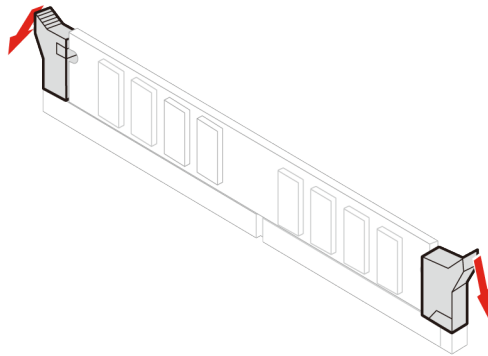

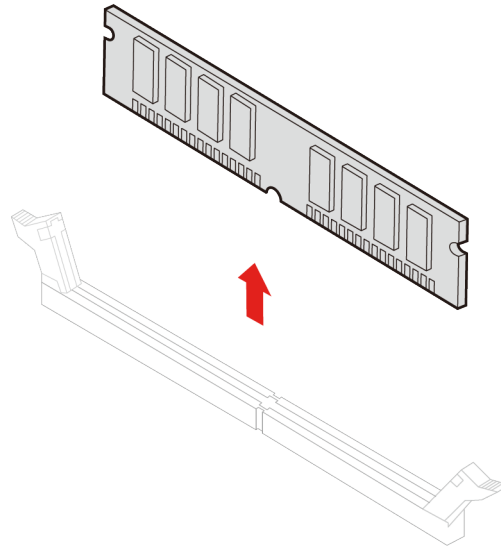

M.2 solid-state drive and heatsink

Prerequisite

Before you start, read *General safety and compliance notice*, and print the following instructions.



The heatsink might be very hot. Before you open the computer cover, turn off the computer and wait several minutes until the computer is cool.

Attention: The M.2 solid-state drive is sensitive. Inappropriate handling might cause damage and permanent loss of data. When handling M.2 solid-state drive, observe the following guidelines:

- Replace the M.2 solid-state drive only for upgrade or repair. The M.2 solid-state drive is not designed for frequent changes or replacement.
- Before replacing the M.2 solid-state drive, make a backup copy of all the data that you want to keep.
- Do not touch the contact edge of the M.2 solid-state drive. Otherwise, M.2 solid-state drive might get damaged.
- Do not apply pressure to the M.2 solid-state drive.
- Do not make the M.2 solid-state drive subject to physical shocks or vibration. Put the M.2 solid-state drive on a soft material, such as cloth, to absorb physical shocks.

For access, do the following:

1. Remove the power cord. See “Power cord” on page 12.
2. Remove the computer cover. See “Computer cover” on page 12.
3. Remove the storage drive cage. See “Storage drive cage” on page 14.

The following illustration shows the location of the M.2 solid-state drive on the system board.

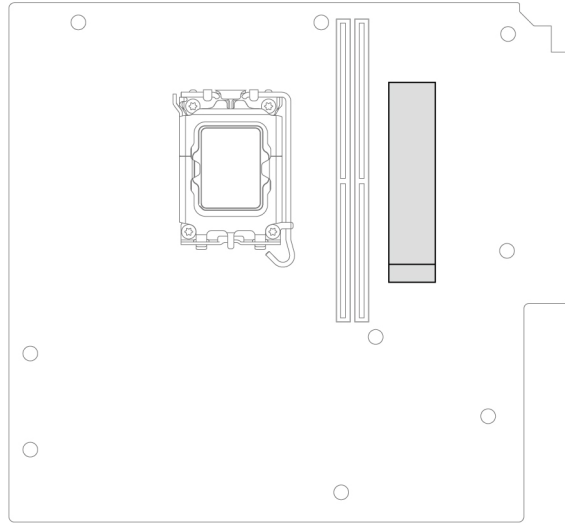

Removal steps

- **Type 1**

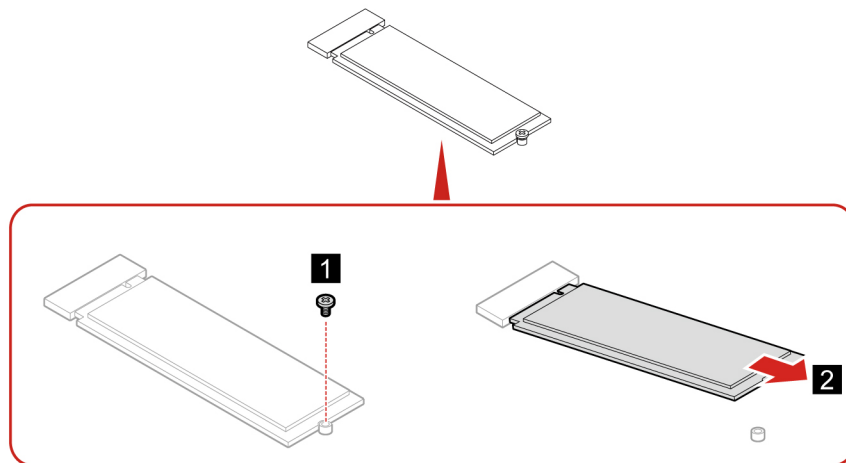

- **Type 2**

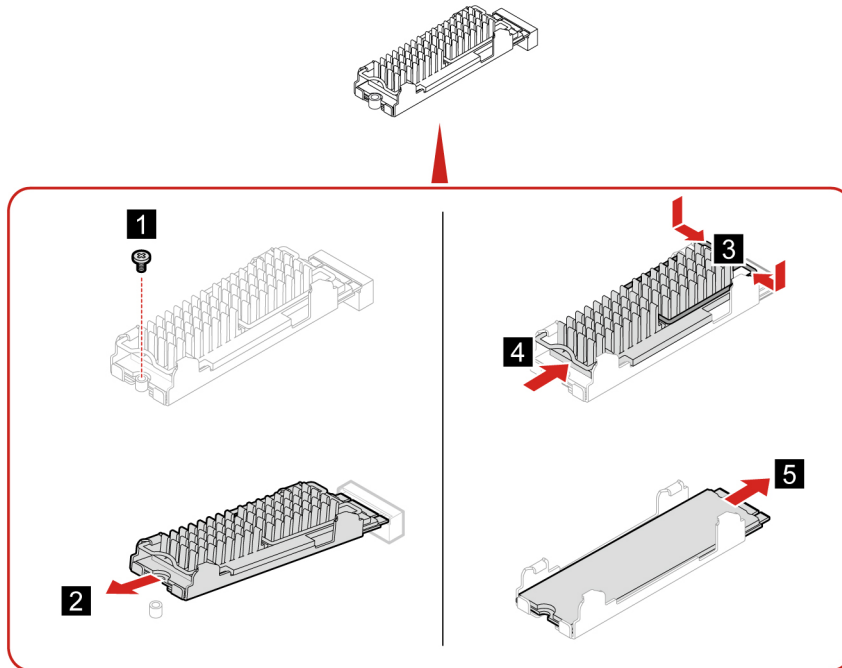

Note: Remove the film that covers the thermal pad (if any) when installing the M.2 solid-state drive and heatsink.

PCI-Express card and PCI-Express card holder

Prerequisite

Before you start, read *Generic Safety and Compliance Notices*, and print the following instructions.



The PCI-Express card might be very hot. Before you open the computer cover, turn off the computer and wait several minutes until the computer is cool.

For access, do the following:

1. Remove the power cord. See “Power cord” on page 12.
2. Remove the computer cover. See “Computer cover” on page 12.
3. Remove the side system fan cable (if any) from the system board.

Removal steps

- Type 1

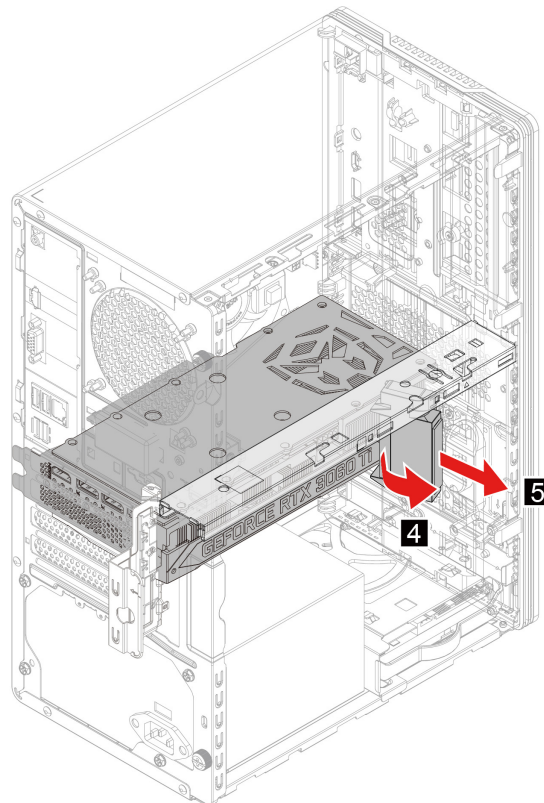
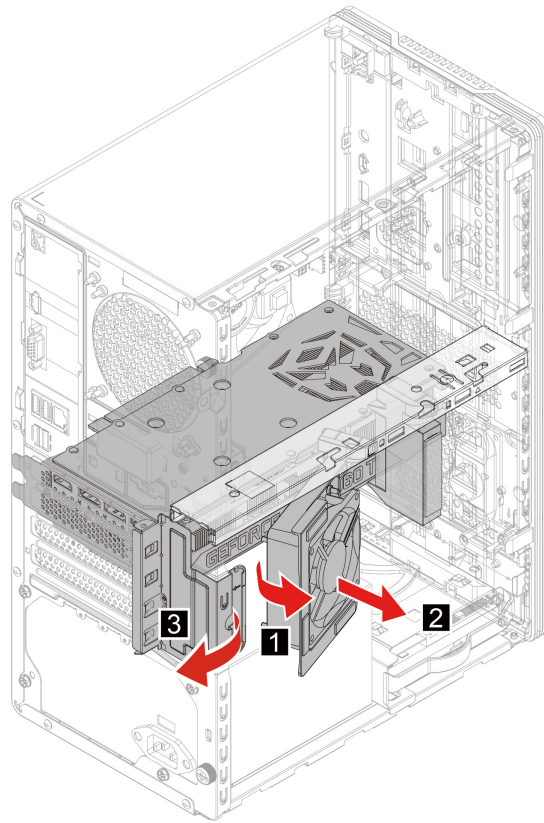

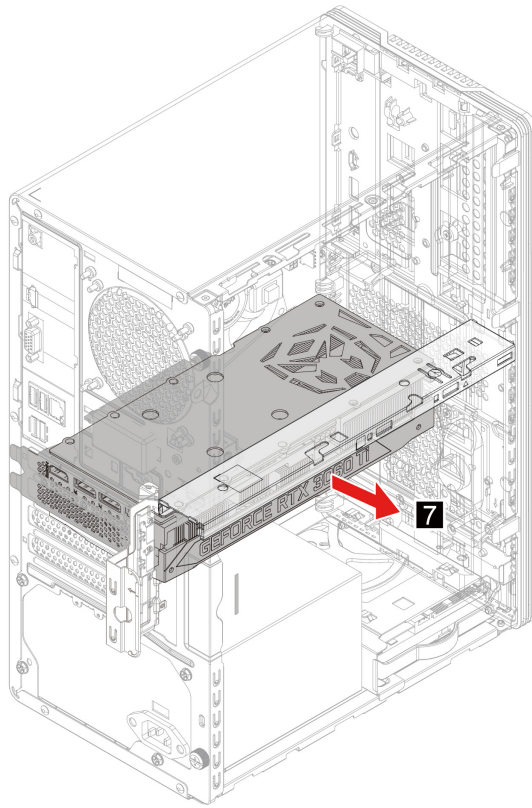
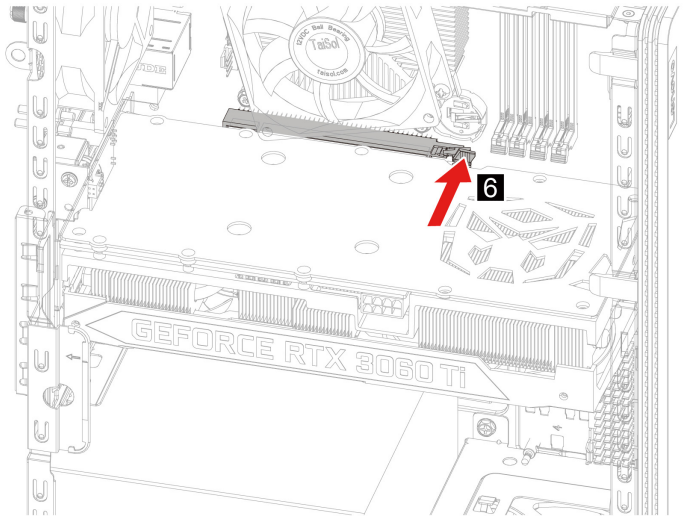

- Type 2

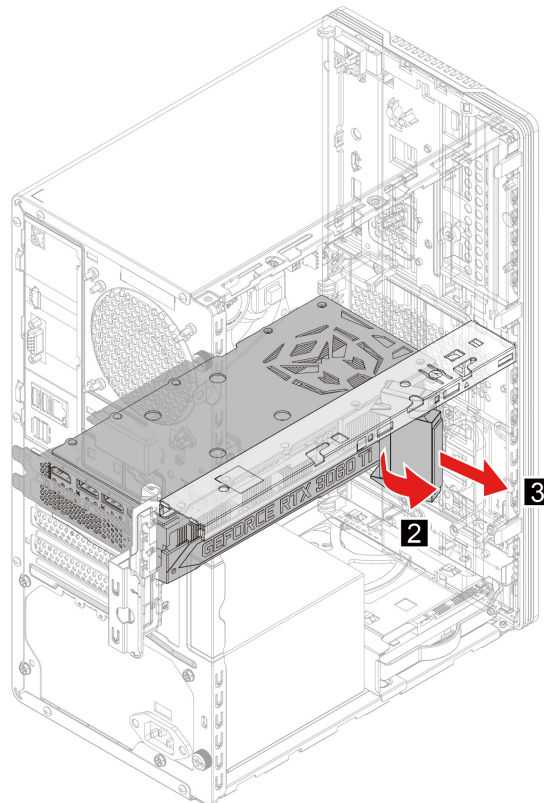
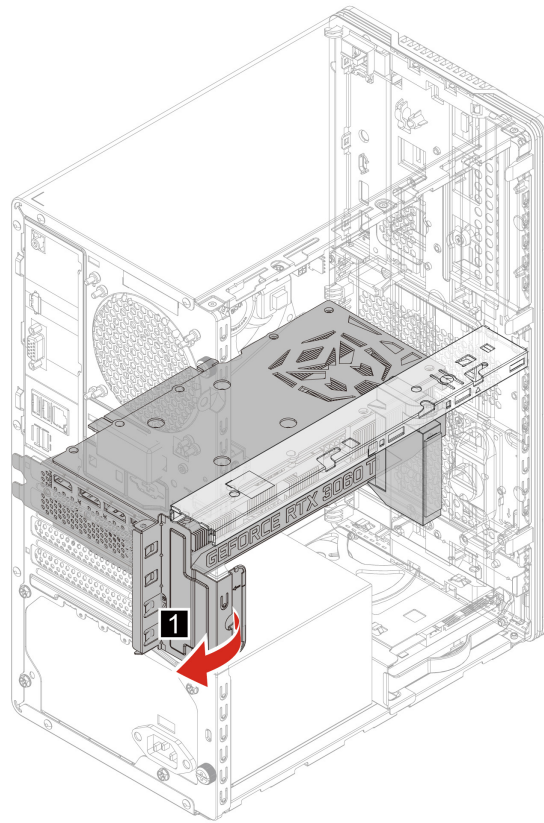

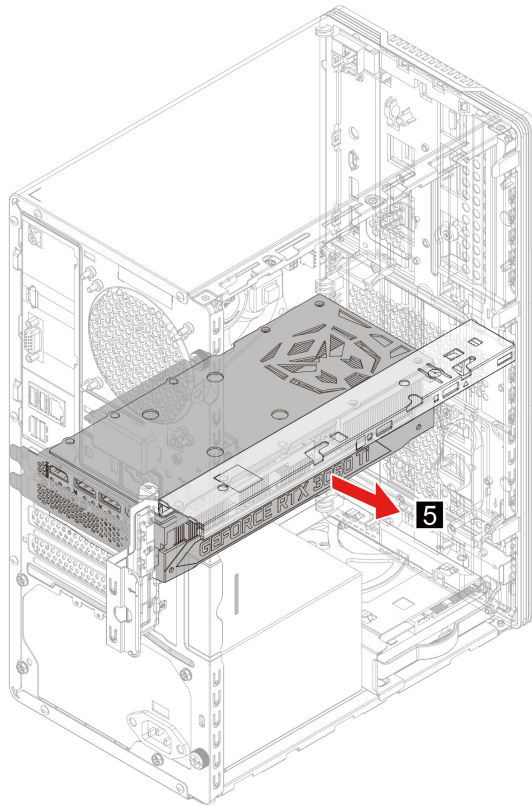
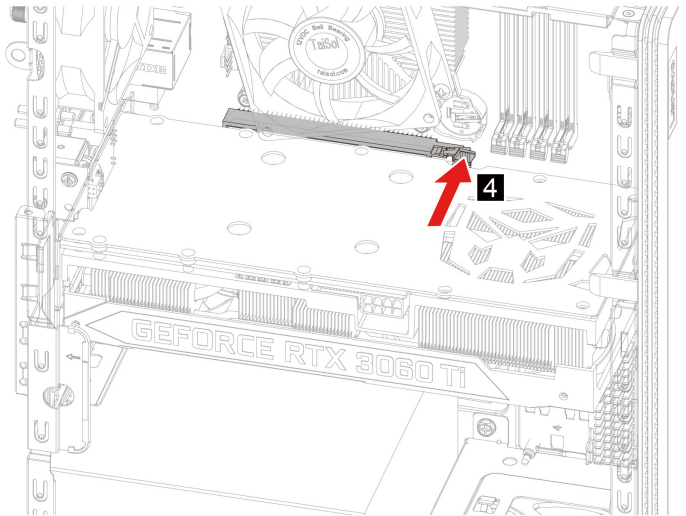

- Type 3

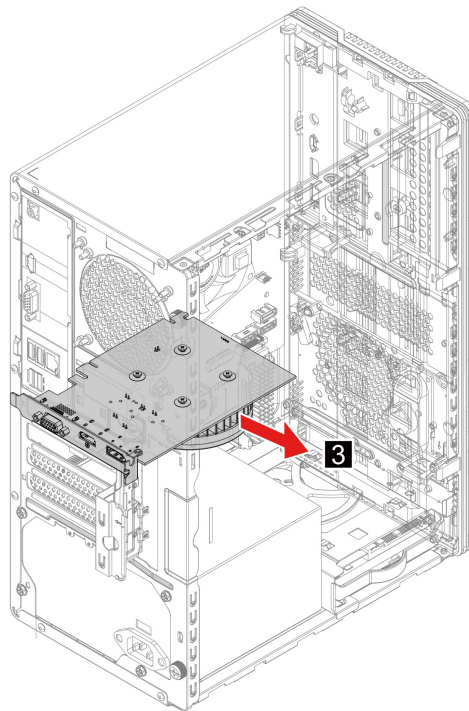
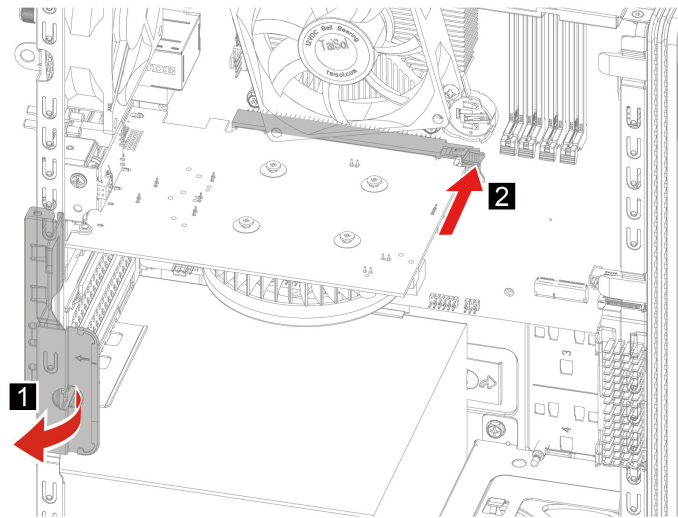

Power supply assembly

Prerequisite

Before you start, read *Generic Safety and Compliance Notices*, and print the following instructions.

Although there are no moving parts in the computer after the power cord has been disconnected, the following warnings are required for your safety.



Keep fingers and other parts of your body away from hazardous, moving parts. If you suffer an injury, seek medical care immediately. Never remove the cover on a power supply or any part that has the following label attached.



Hazardous voltage, current, and energy levels are present inside any component that has this label attached. There are no serviceable parts inside these components. If you suspect a problem with one of these parts, contact a service technician.

For access, do the following:

1. Remove the power cord. See “Power cord” on page 12.
2. Remove the computer cover. See “Computer cover” on page 12.
3. Remove the 3.5-inch storage drive. See “3.5-inch storage drive” on page 15.
4. Disconnect the power supply assembly cables from the system board.

Removal steps

- Type 1

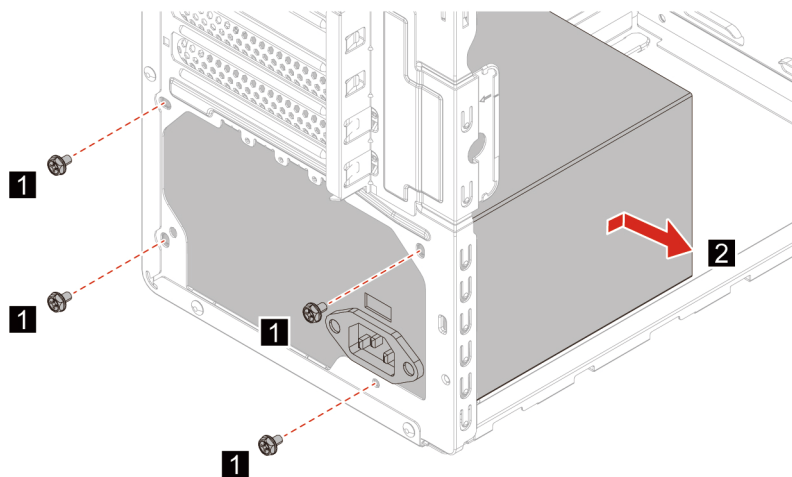

- Type 2

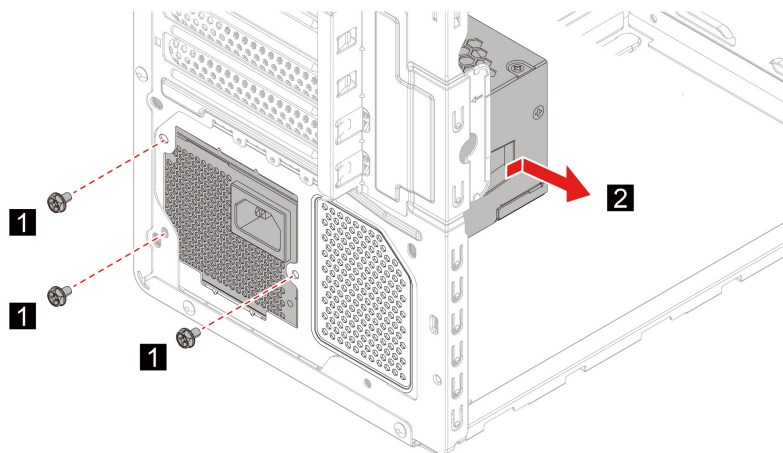

Chapter 4. Help and support

Find your serial number

This topic helps you find computer serial number.

You can find your serial number via:

- **Dashboard** or **Device** in the **Vantage** app
- Serial number and machine type label of your computer (shown as below illustration)

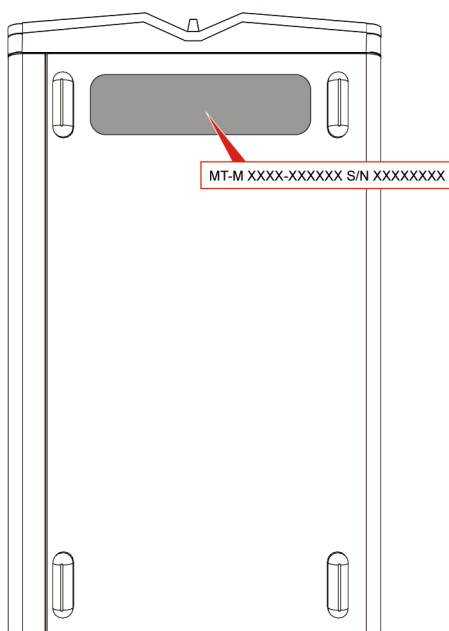

Diagnose and troubleshoot your computer

This section provides introduction to a set of diagnostics and troubleshooting tools at Lenovo Support Web site and the Vantage app. They can help you diagnose common software and hardware issues.

The following table lists these diagnostics tools and the recommended conditions for each tool.

Diagnostics tool	Recommended scenario
Troubleshoot and diagnose at Lenovo Support Web site	You want to have an online troubleshooting or scan of hardware and drivers on your computer.
Hardware scan	<ul style="list-style-type: none">• Your computer is installed with the Vantage app.• You want to perform basic examinations of the hardware components.

Troubleshoot and diagnose at Lenovo Support Web site

Lenovo provides two different diagnosing solutions to help you identify and resolve problems on your computer.

Step 1. Go to <https://www.pcsupport.lenovo.com/> and enter your product name in the search box.

Step 2. Click **Troubleshoot & Diagnose** and select the option that fits your need.

Notes:

- Before launching any automatic diagnosing process, a pop-up window will be prompted to install Lenovo Service Bridge. Lenovo Service Bridge helps to connect your computer with Lenovo diagnosing tools.
- Lenovo Support Web site makes periodic updates of the sections to keep improving your experience with your computer. The Web site interface and descriptions of sections might be different from that on your actual interface.
- If you are unaware of what problem your computer goes with, it is recommended that you select **Easy** and follow on-screen instructions to get your firmware updated and obtain the hardware status.
- If you have identified the problem on your computer, you can select **Custom** and follow on-screen instructions to resolve the problem.

If solutions can not resolve problems on your computer, you can follow on-screen instructions to submit an e-ticket or contact Lenovo for professional assistance.

Hardware scan

Hardware scan is an effective hardware testing tool to help you identify existing hardware issues.

To run the Hardware scan:

Step 1. Type **Vantage** in the Windows search box and then press Enter.

Step 2. Click **Hardware scan** or **Support → Hardware scan**.

Step 3. Select **QUICK SCAN** or **CUSTOMIZE** and then follow the on-screen instructions to run the hardware scan.

Notes:

- The Quick Scan tool contains a pre-selected suite of tests that performs basic examinations of the hardware components found in the system. The Customize tool enables you to select one or several hardware components to perform the examinations.
 - Before selecting **QUICK SCAN**, click **Refresh Modules** to ensure that the listed hardware components are the components currently available for the computer.
- Step 4. If any hardware failure is detected, the result varies depending on the warranty status and varies by country or region. Follow the on-screen instructions to resolve the issue.

Recover Windows operating system

This topic provides the instructions of recovering a Windows operating system.

Use the following recovery options to reset or restore your computer when your computer comes with issues. It is recommended that you select Lenovo recovery options to reset your operating system to original factory conditions.

- Use Lenovo recovery options: Connect the drive that contains the operating system installation program to the computer. To create the Lenovo recovery media, refer to <https://support.lenovo.com/HowToCreateLenovoRecovery>.
- Use Windows recovery options:
 1. Microsoft constantly makes updates to the Windows operating system. Before installing a particular Windows version, check the compatibility list for the Windows version. For details, go to <https://support.lenovo.com/us/en/solutions/ht512575>.
 2. Connect the drive that contains the operating system installation program to the computer. To create the installation media, refer to <https://support.microsoft.com/windows>.

Call Lenovo

If you have tried to correct the problem yourself and still need help, you can call Lenovo Customer Support Center.

Before you contact Lenovo

Prepare the needed information before you contact Lenovo.

1. Record the problem symptoms and details:
 - What is the problem? Is it continuous or intermittent?
 - Any error message or error code?
 - What operating system are you using? Which version?
 - Which software applications were running at the time of the problem?
 - Can the problem be reproduced? If so, how?
2. Record the system information:
 - Product name
 - Machine type and serial number.

Self-help resources

Use the following self-help resources to learn more about the computer and troubleshoot problems.

Resources	How to access?
Lenovo Support Web Site	https://pcsupport.lenovo.com
Tips	https://www.lenovo.com/tips
Lenovo Community	https://forums.lenovo.com
Accessibility information	https://www.lenovo.com/accessibility
Windows help information	<ul style="list-style-type: none"> • Open the Start menu and click Get Help or Tips. • Use Windows Search or the Cortana® personal assistant. • Microsoft support Web site: https://support.microsoft.com

Purchase accessories or additional services

This topic provides instructions on how to purchase accessories or additional services.

Accessories

Lenovo has a number of hardware accessories and upgrades to help expand the functionalities of your computer. Accessories include memory modules, storage devices, network cards, power adapters, keyboards, mice, and so on.

- For mainland China, go to <https://www.lenovo.com.cn>.
- For other countries or regions, go to <https://www.lenovo.com/accessories>.

Additional services

During and after the warranty period, you can purchase additional services from Lenovo at <https://pcsupport.lenovo.com/warrantyupgrade>

Service availability and service names might vary by country or region.

Appendix A. Notices and trademarks

Notices

Lenovo may not offer the products, services, or features discussed in this document in all countries. Consult your local Lenovo representative for information on the products and services currently available in your area. Any reference to a Lenovo product, program, or service is not intended to state or imply that only that Lenovo product, program, or service may be used. Any functionally equivalent product, program, or service that does not infringe any Lenovo intellectual property right may be used instead. However, it is the user's responsibility to evaluate and verify the operation of any other product, program, or service.

Lenovo may have patents or pending patent programs covering subject matter described in this document. The furnishing of this document does not give you any license to these patents. You can send license inquiries, in writing, to:

*Lenovo (United States), Inc.
8001 Development Drive
Morrisville, NC 27560
U.S.A.
Attention: Lenovo Director of Licensing*

LENOVO PROVIDES THIS PUBLICATION "AS IS" WITHOUT WARRANTY OF ANY KIND, EITHER EXPRESS OR IMPLIED, INCLUDING, BUT NOT LIMITED TO, THE IMPLIED WARRANTIES OF NON-INFRINGEMENT, MERCHANTABILITY OR FITNESS FOR A PARTICULAR PURPOSE. Some jurisdictions do not allow disclaimer of express or implied warranties in certain transactions, therefore, this statement may not apply to you.

Changes are made periodically to the information herein; these changes will be incorporated in new editions of the publication. To provide better service, Lenovo reserves the right to improve and/or modify the products and software programs described in the manuals included with your computer, and the content of the manual, at any time without additional notice.

The software interface and function and hardware configuration described in the manuals included with your computer might not match exactly the actual configuration of the computer that you purchase. For the configuration of the product, refer to the related contract (if any) or product packing list, or consult the distributor for the product sales. Lenovo may use or distribute any of the information you supply in any way it believes appropriate without incurring any obligation to you.

The products described in this document are not intended for use in implantation or other life support applications where malfunction may result in injury or death to persons. The information contained in this document does not affect or change Lenovo product specifications or warranties. Nothing in this document shall operate as an express or implied license or indemnity under the intellectual property rights of Lenovo or third parties. All information contained in this document was obtained in specific environments and is presented as an illustration. The result obtained in other operating environments may vary.

Lenovo may use or distribute any of the information you supply in any way it believes appropriate without incurring any obligation to you.

Any references in this publication to non-Lenovo Web sites are provided for convenience only and do not in any manner serve as an endorsement of those Web sites. The materials at those Web sites are not part of the materials for this Lenovo product, and use of those Web sites is at your own risk.

Any performance data contained herein was determined in a controlled environment. Therefore, the result obtained in other operating environments may vary significantly. Some measurements may have been made on development-level systems and there is no guarantee that these measurements will be the same on generally available systems. Furthermore, some measurements may have been estimated through extrapolation. Actual results may vary. Users of this document should verify the applicable data for their specific environment.

This document is copyrighted by Lenovo and is not covered by any open source license, including any Linux® agreement(s) which may accompany software included with this product. Lenovo may update this document at any time without notice.

For the latest information or any questions or comments, contact or visit the Lenovo Web site:

<https://pcsupport.lenovo.com>

Trademarks

Lenovo, the Lenovo logo, Lenovo LOQ, and the LOQ logo are trademarks of Lenovo. Intel, Intel Optane, and Thunderbolt are trademarks of Intel Corporation or its subsidiaries in the U.S. and/or other countries. Linux is the registered trademark of Linus Torvalds in the U.S. and other countries. Microsoft, Windows, and Cortana are trademarks of the Microsoft group of companies. The terms HDMI and HDMI High-Definition Multimedia Interface are trademarks or registered trademarks of HDMI Licensing LLC in the United States and other countries. USB-C is a registered trademark of USB Implementers Forum. Wi-Fi and Miracast are registered trademarks of Wi-Fi Alliance. ENERGY STAR is a trademark of the U.S. Environmental Protection Agency. All other trademarks are the property of their respective owners.

Lenovo