

Workstation - White

Assembly Instructions - Please keep for future reference

7609545

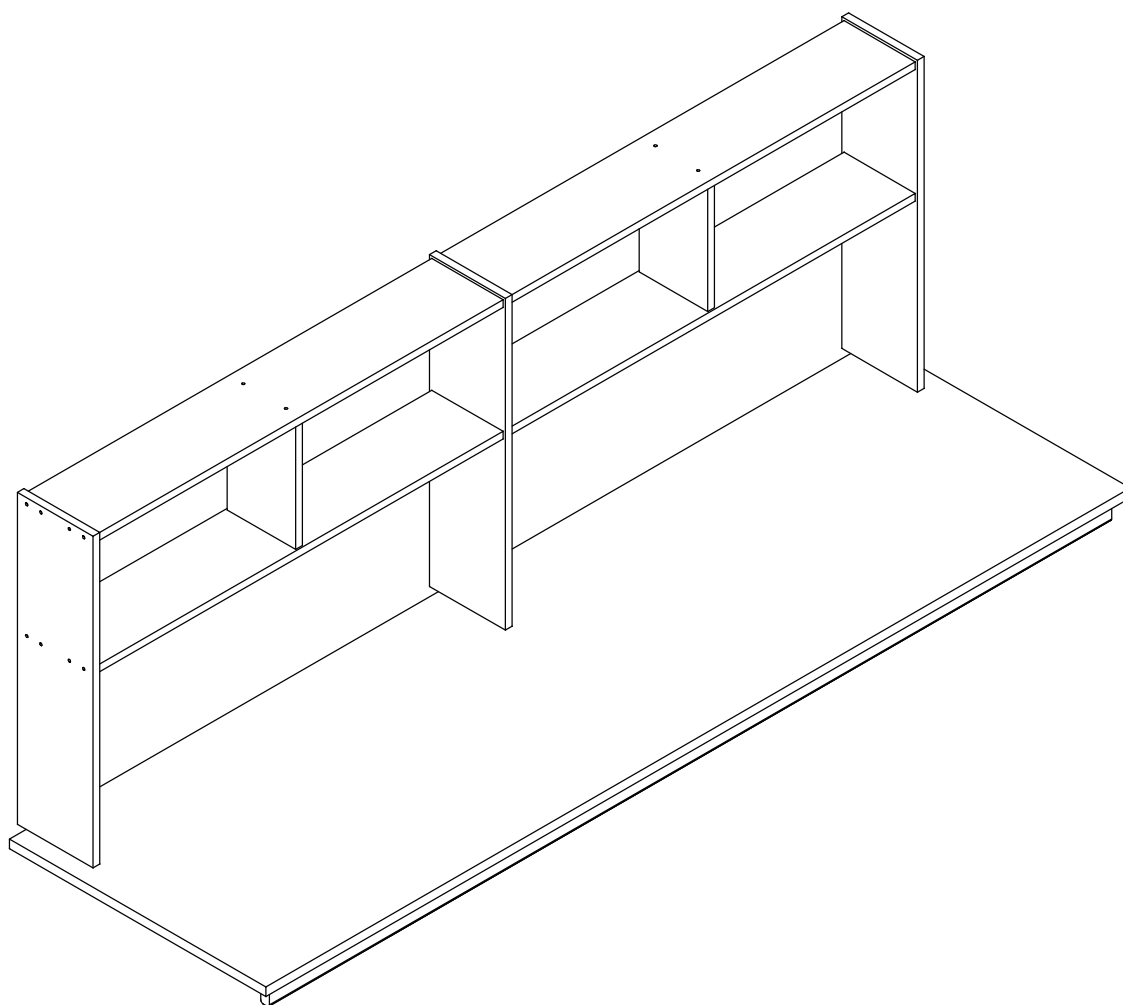

Dimensions

Length - 194cm
Depth - 59,5cm
Height - 70cm
Weight - 24,5kg

Important – Please read these instructions fully before starting assembly

If you need help or have damaged or missing parts, call the **Customer Helpline:**

0045 7668 8055 or e-mail: order@flexa.dk

Safety and Care Advice

Important – Please read these instructions fully before starting assembly

- Check you have all the components and tools listed on pages 2 and 3.
- Remove all fittings from the plastic bags and separate them into their groups.
- During assembly children should be kept away from the product due to possible risk of injury.
- Make sure you have enough space to layout the parts before starting.

- Do not stand or put weight on the product, this could cause damage.
- Assemble the item as close to its final position (in the same room) as possible.
- Assemble on a soft level surface to avoid damaging the unit or your floor.
- Parts of the assembly will be easier with 2 people.
- Do not use this item if any components are missing or damaged



- We do not recommend the use of power drill/drivers **for inserting screws**, as this could damage the unit. Only use hand screwdrivers.
- Dispose of all packaging carefully and responsibly.
- Assembly to be carried out by a competent adult only.

Care and maintenance

- Only clean using a damp cloth and mild detergent, do not use bleach or abrasive cleaners.
- Regularly check all fastenings to ensure that they properly tightened.
- This product should not be discarded with household waste. Take to your local authority waste disposal centre.
- This product is suitable for children in the age 4-12 years. Maximum load on tabletop 20 kg. Maximum load on shelf 7 kg.

Note: if required the next page can be cut out and used as reference throughout the assembly. Keep this page with these instructions for future reference.

Components - Parts

If you have damaged or missing components,
call the **Customer Helpline: 0045 7668 8055**

Please check you have all the parts listed below

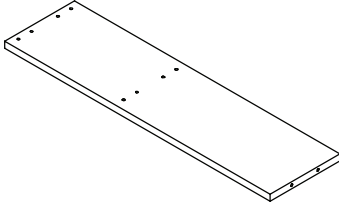

1 Side panel x3
(64.5x17x1.5cm)
No. 15-01506451-40

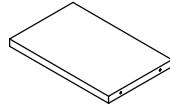

2 Partition x2
(24.1x15.4x1.5cm)
No. 15-01502411-40

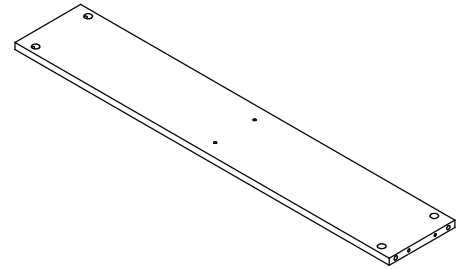

3 Shelf x4
(91x16x1.5cm)
No. 15-01509101-40

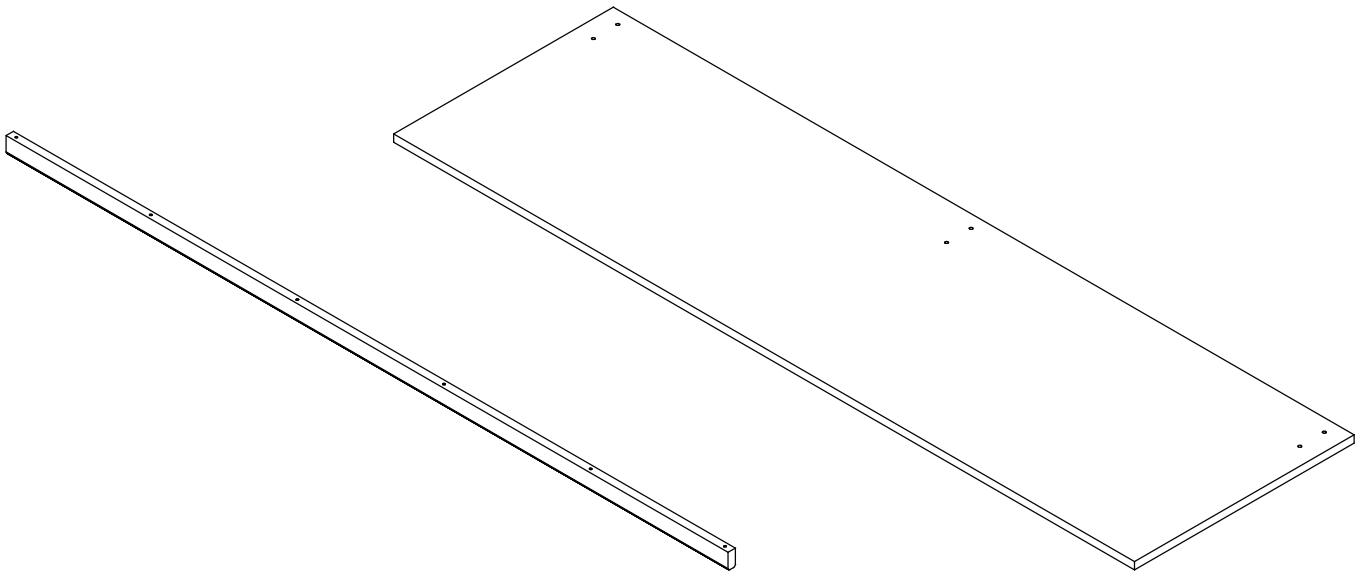

4 Support rail x1
(189x4.2x1.5cm)
No. 12-01518901-40







5 Table top x1
(194x57.5x1.9cm)
No. 4301-1919401-40

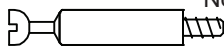

Components - Fittings

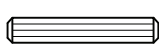
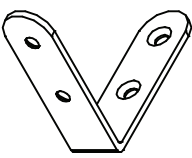
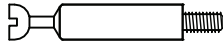
Please check you have all the fittings listed below

Note: The quantities below are the correct amount to complete the assembly. In some cases more fittings may be supplied than are required.

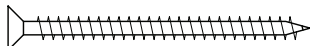
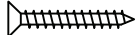
| | | |
|---|--|---|
| A  No. 4020-005 Ø7x34mm for Ø5 Minifix bolt x8 | B  No. 3933-15010 Ø15x9.5mm Minifix cam x16 | C  No. 3930-05030 Ø5x30mm Dowel x16 |
| D  No. 4008-019 50x50x15x2mm Angle x5 | E  No. 4020-006 Ø7/M4x34mm Minifix bolt x8 | F  No. 3924-04015 Ø5/M4x15mm Sleeve connector x4 |
| G  No. 3908-70040 7.0x40mm Confirmat screw x6 | H  No. 3901-40040 4.0x40mm Chipboard screw x8 | |
| I  No. 3901-45055 4.5x55mm Chipboard screw x6 | J  No. 3901-35020 3.5x20mm Chipboard screw x20 | |

Tools required

Phillips
screwdriver
(medium)

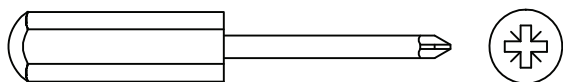

Flatblade
screwdriver
(medium)

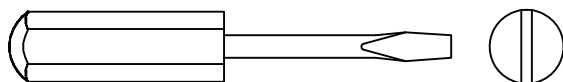

Allen key
4mm incl.
No. 4033-004

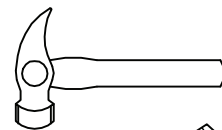
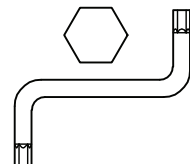

Small
hammer

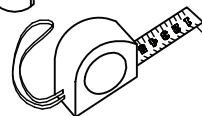

Ruler/tape
measure



Eye protection
(when using a
hammer or glue)

Assembly Instructions

Step 1

Attach M4 minifix bolts **E** and M4 sleeve connectors **F** to one of the side panels **1**.

Attach minifix bolts **A** to the remaining two side panels **1**.

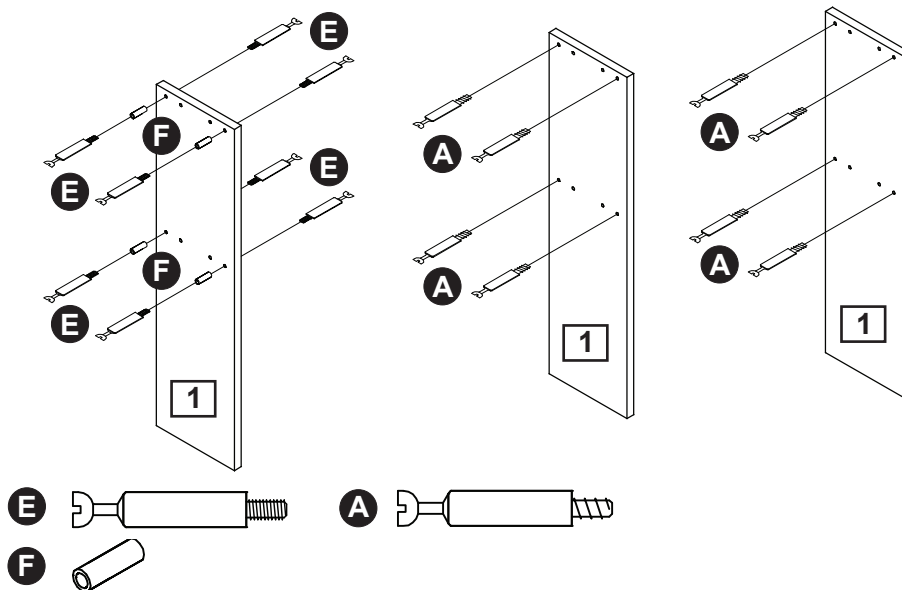

Step 2

Attach the dowels **C** to the shelf **3**.

It may be necessary to tap the dowels in very gently with a small hammer.

Repeat for all shelves.

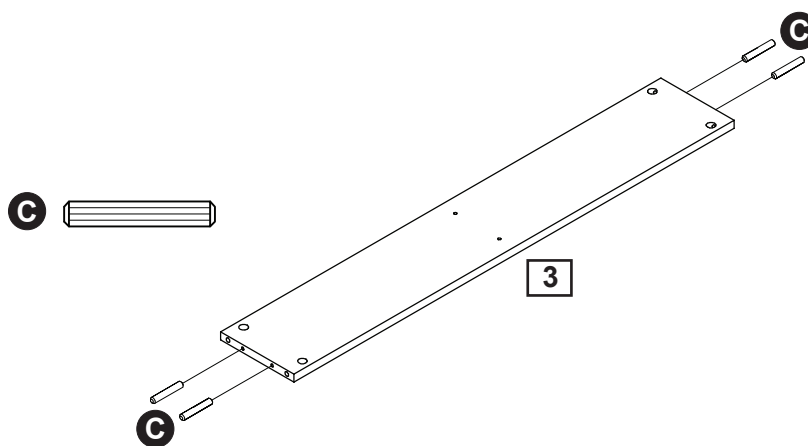

Step 3

Attach partitions **2** to shelves **3** from both sides with screw **H**.

Attach shelves **3** to the side panels **1** with minifix cams **B**.

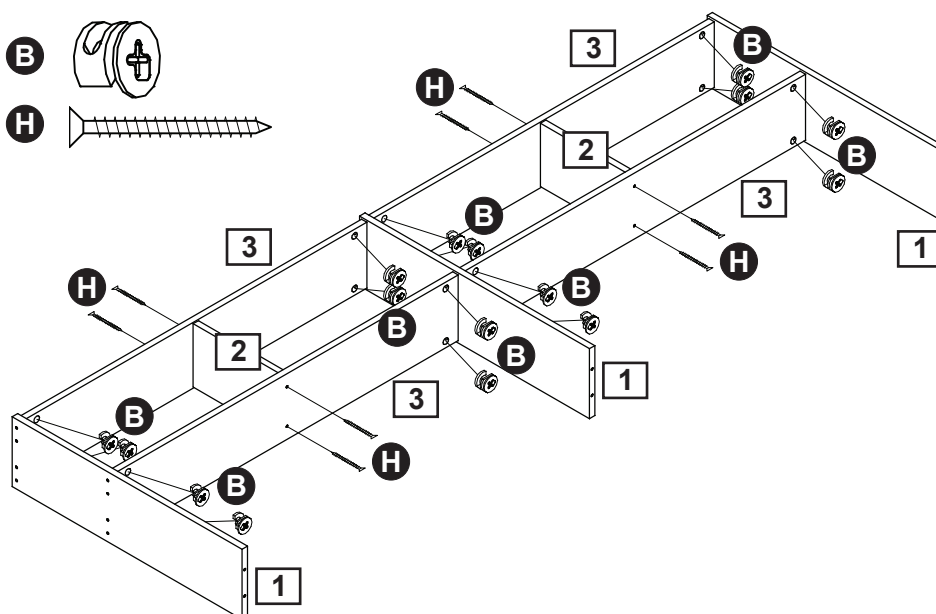

Assembly Instructions

Step 4

Place the table top **5** under the bed onto endrails. Distribute evenly.

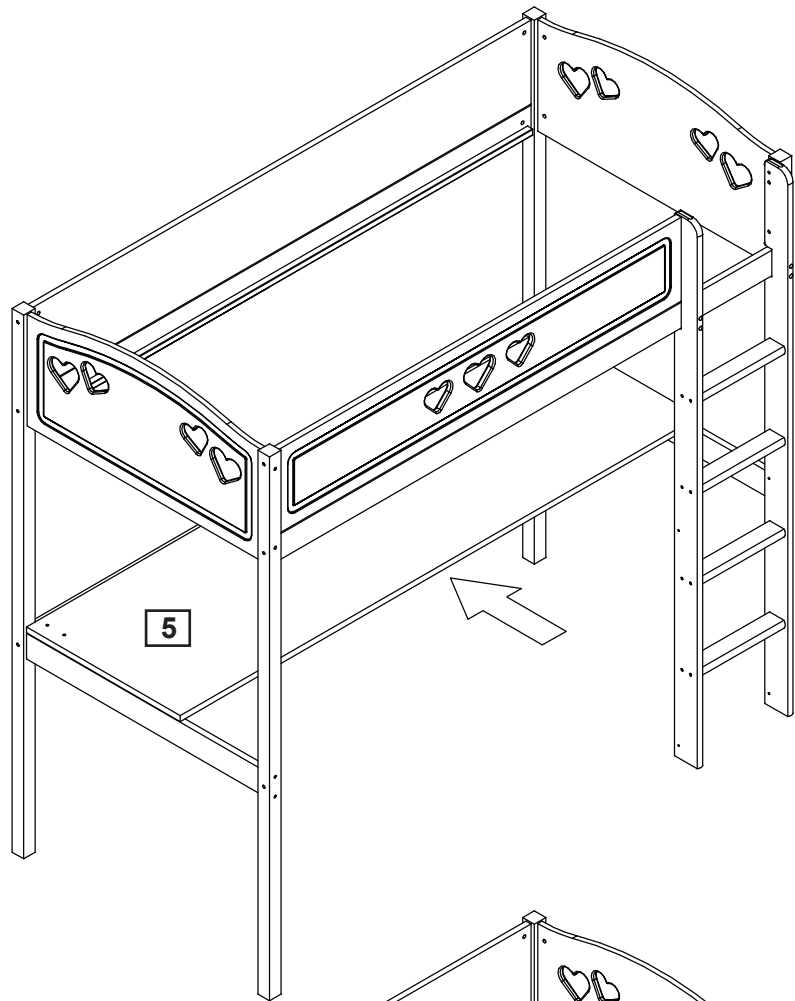

Step 5

Place previously assembled shelf unit onto the table top **5**.

Attach all three side panels **1** to the table top **5** with screws **G**.

Don't overtighten.

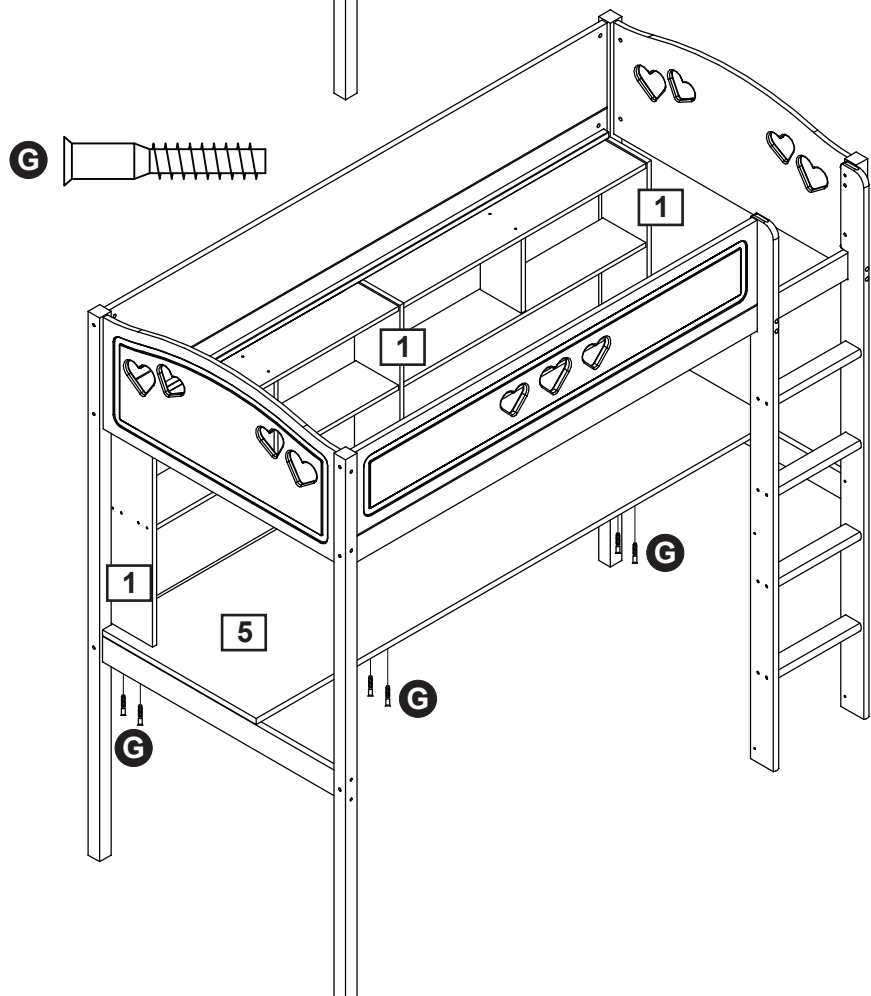

Assembly Instructions

Step 6

Attach the support rail **4** under the table top **5** with screws **i**.

Follow the marking holes under the table top **5**.

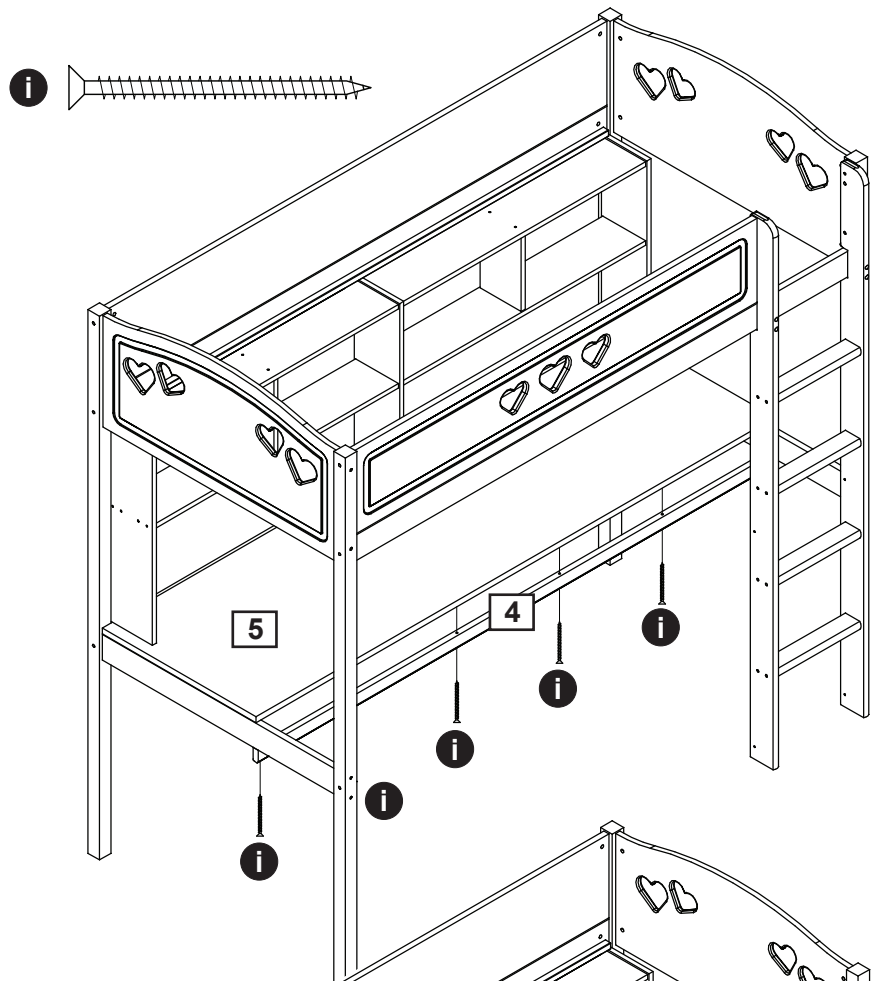

Step 7

Attach angles **D** under the table top **5** with screws **J**.

Make sure the table top **5** is lifted up so that the underside of the table top **5** is flush with the upper edge of the back rail before mounting the middle angle **D**.

Note: Be aware that when assembling Workstation onto "Brooklyn" (6018137) High sleeper - There should be 6mm gaps between endrails and support rail **4.**

No gaps on Heart (7648434) and Star (8047357) High sleepers.

Assembly is complete.

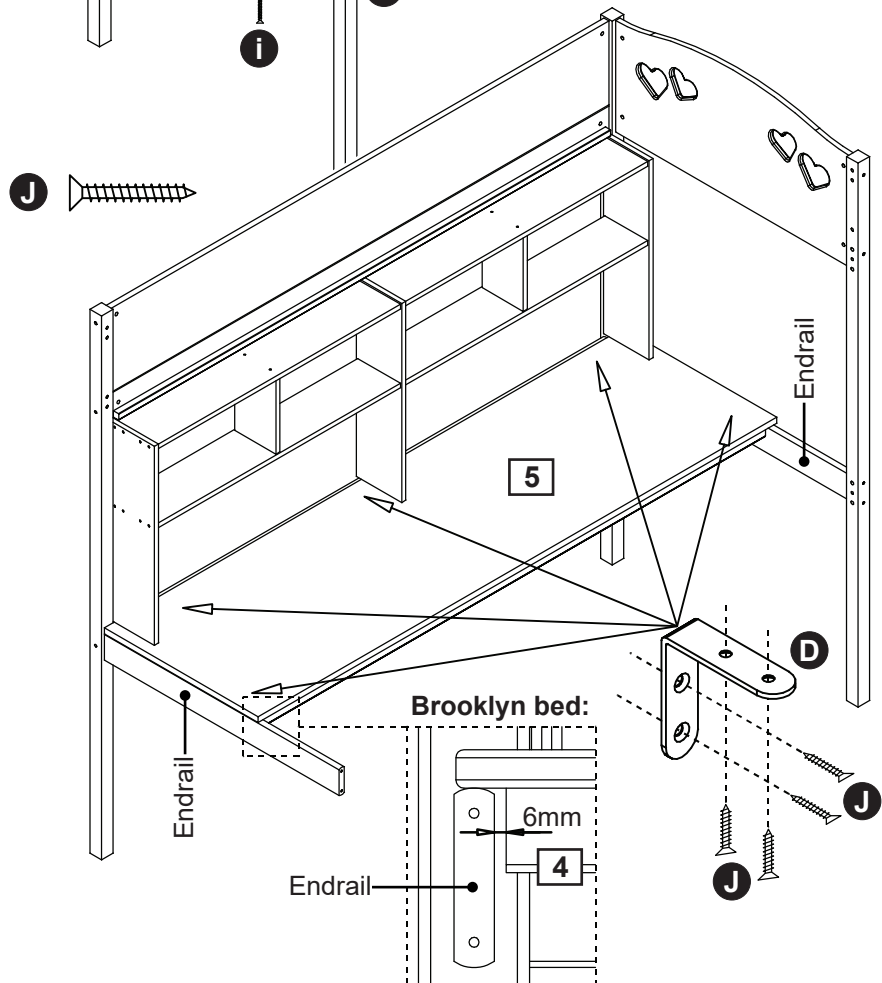

If you need help or have damaged or missing parts, call the **Customer Helpline: 0045 7668 8055**
E-mail: order@flexa.dk

Your 2 Year Guarantee

Peace Of Mind

Knowing Your Furniture Is Protected

| Protection received within the Manufacturer's Guarantee | Optional Added Protection with Furniture Care |
|--|---|
| Covers you for manufacturing defects for 2 years. | Covers you for accidental damage up to 3 years for incidents such as household spills, rips, tears and burns. Accidental damage cover begins from the moment your plan starts. |
| In the event of a problem within this time please call 0345 640 0800 , or visit an Argos store. Please retain your receipt and order number as proof of purchase. | If you want to purchase Furniture Care visit https://argos.productaftercare.co.uk or go into an Argos store. |
| Key exclusions applying to both the Manufacturer's Guarantee and Furniture Care include where the fault is due to misuse, abuse, deliberate damage, wear and tear, neglect, use in contravention with the instructions, or if the product has been the subject of unauthorised alterations or commercial use (for full list of exclusions please visit https://argos.productaftercare.co.uk or visit an Argos store for more information). You have up to 45 days post purchase to take out Furniture Care. Terms and conditions apply. Your statutory rights remain unaffected. | |

Register

For Your Manufacturer's Guarantee

Thank you for choosing Argos Home.
We hope you love your shiny new things!

To provide you with the best possible after sales service, don't forget to visit **<https://argos.productaftercare.co.uk>** where you can **register** for your guarantee.

Once you've registered, you can upload your receipt to store safely online, alongside details of our after sales support service, ready at hand should you need it.

You can also take out Furniture Care which protects you against accidental damage, from the moment you take the plan out, to keep your new furniture looking newer for longer.

Register Today

<https://argos.productaftercare.co.uk>