

Shark[®] ***Lift-Away***[™]

NV601UK

Series

INSTRUCTIONS



sharkclean.eu



0800 862 0453



THANK YOU

for purchasing the Shark[®] Lift-Away™



 **TIP:** You can find the model, date code and serial numbers on the QR code label located on the back of your unit.

REGISTER YOUR PURCHASE

-  sharkclean.eu/uk/register-guarantee
-  0800 862 0453
-  Scan QR code using mobile device

RECORD THIS INFORMATION

Model Number: _____
Serial Number _____
Date Code: _____
Date of Purchase (Keep receipt): _____
Store of Purchase: _____

TECHNICAL SPECIFICATIONS

Voltage: 220-240V~, 50-60Hz
Watts: 750W
Power Nozzle: 80W

PLEASE READ CAREFULLY AND KEEP FOR FUTURE REFERENCE.

This Owner's Guide is designed to help you get a complete understanding of your new Shark Lift-Away.

If you have any questions, please call the customer service line at 0800 862 0453.



CONTENTS

Important Safety Instructions	3
Getting to Know Your Shark® Lift-Away™	5
Assembling Your Vacuum	7
Using Your Vacuum in Upright Mode	9
What Does the Brushroll Indicator Light Mean?	9
Using Your Vacuum in Above-Floor Mode	11
The Benefits of Suction Control	11
Using Your Vacuum in Lift-Away™ Mode	13
Lift-Away Cleaning	13
Compatible Accessories	15
Maintenance	17
Emptying the Dust Cup	17
Cleaning the Filters	19
Checking for Blockages & Maintaining Brushroll	20
Troubleshooting Guide	21
Warranty	22

This appliance complies with the WEEE-Directive 2012/19/EU on the disposal of electrical and electronic equipment (WEEE).



This marking indicates that this product should not be disposed with other household wastes throughout the EU. To prevent possible harm to the environment or human health from uncontrolled waste disposal, recycle it responsibly to promote the sustainable reuse of material sources. To return your used device, please use the return and collection systems or contact the retailer where this product was purchased. They can take this product for environmental safe recycling.

This appliance complies with the European directives for electromagnetic compatibility (EMC) 2014/30/EU and its revisions, as well as Low Voltage Directive (LVD) 2014/35/EU and its revisions.

IMPORTANT SAFETY INSTRUCTIONS

PLEASE READ CAREFULLY BEFORE USE • FOR HOUSEHOLD USE ONLY

⚠ WARNING

This appliance is not intended for use by persons with reduced physical, sensory or mental capabilities, or lack of experience and knowledge, unless they have been given supervision or instruction concerning the use of the appliance by a person responsible for their safety. Children shall not use or play with appliance. close supervision is necessary to keep appliance out of reach of children during use.

CAUTION: THE POWER NOZZLE, WAND, AND HANDLE CONTAIN ELECTRICAL CONNECTIONS:

- These are not serviceable parts.
 - Do not use to suck up water.
 - Do not immerse in water for cleaning.
 - The handle/wand should be checked regularly and must not be used if damaged.
-

- 1** Inspect supply cord and plug for any damage before use. If the supply cord is damaged, it must be replaced by SharkNinja Operating LLC, its service agent or similarly qualified persons in order to avoid a hazard. DO NOT use vacuum cleaner with a damaged or plug. Turn off all controls before plugging in or unplugging the vacuum cleaner. Store your vacuum cleaner with the supply cord secured around the two cord hooks.
- 2** DO NOT use outdoors or on wet surfaces. Use only on dry surfaces.
- 3** The plug must be removed from the socket-outlet before cleaning or maintaining the appliance.
- 4** If vacuum cleaner is not working as it should, or has been dropped, damaged, left outdoors, or dropped into water, return it to Euro-Pro Europe Limited for examination, repair, or adjustment.
- 5** The hose contains electrical wires. DO NOT use when damaged, cut, or punctured.

- 6** DO NOT pull or carry vacuum cleaner by the cord or use the cord as a handle.
- 7** DO NOT unplug by pulling on cord. Grasp the plug, not the cord.
- 8** DO NOT handle plug or vacuum cleaner with wet hands.
- 9** DO NOT run the vacuum cleaner over the power cord, close a door on the cord, or pull the cord around sharp corners.
- 10** The use of an extension cord is NOT recommended.
- 11** DO NOT leave vacuum cleaner unattended when plugged in.
- 12** Keep cord away from heated surfaces.
- 13** Always turn off the vacuum cleaner before connecting or disconnecting motorised nozzle.

GENERAL USE

- 14** Use only as described in this manual.
- 15** Keep your work area well lit.
- 16** Keep the vacuum cleaner moving over the carpet surface at all times to avoid damaging the carpet fibers.
- 17** DO NOT place vacuum cleaner on unstable surfaces such as chairs or tables.
- 18** DO NOT put any objects into openings. DO NOT use with any opening blocked; keep free of dust, lint, hair, and anything that may reduce airflow.

19 DO NOT allow the appliance to be used by children. Close attention is necessary when used near children. This is not a toy.

20 DO NOT use without dust cup and/or filters in place.

DUST CUP/FILTERS/ACCESSORIES

Before turning on the vacuum:

21 Make sure that all filters are thoroughly dry after routine cleaning.

22 Make sure that dust cup and all filters are in place after routine maintenance.

23 Make sure accessories are free of blockages.

24 Only use Shark®-brand filters and accessories (failure to do so will void the warranty).

HOSE ATTACHMENTS

25 DO NOT use if airflow is restricted. If the air paths or the motorised floor nozzle become blocked, turn the vacuum cleaner off and unplug from electrical outlet. Remove all obstructions before you turn on the unit again.

26 Keep the end of the hose and accessory openings away from face and body.

27 Keep cleaning tools and hose suction openings away from hair, face, fingers, uncovered feet, or loose clothing.

28 Only use manufacturer's recommended attachments.

GENERAL CLEANING

29 DO NOT vacuum up large objects.

30 DO NOT vacuum up hard or sharp objects such as glass, nails, screws, or coins that could damage the vacuum cleaner.

31 DO NOT vacuum up drywall dust, fireplace ash, or embers. DO NOT use as an attachment to power tools for dust collection.

32 DO NOT vacuum up smoking or burning objects such as hot coals, cigarette butts, or matches.

33 DO NOT vacuum up flammable or combustible materials (e.g., lighter fluid, gasoline, or kerosene) or use vacuum in areas where they may be present.

34 DO NOT vacuum up toxic solutions (e.g., chlorine bleach, ammonia, or drain cleaner).

35 DO NOT use in an enclosed space where vapours are present from paint, paint thinner, moth-proofing substances, flammable dust, or other explosive or toxic materials.

36 DO NOT vacuum up any liquids.

37 DO NOT immerse vacuum cleaner in water or other liquids.

38 Use extra care when cleaning on stairs.

SAVE THESE INSTRUCTIONS

GETTING TO KNOW YOUR SHARK® LIFT-AWAY™

WELCOME!

Congratulations on your purchase. Use this Owner's Guide to learn about your new vacuum's great features. From assembly to use to maintenance, you will find it all in here.

MAIN UNIT

- A** Hose
- B** Suction Control
- C** Handle Release Latch
- D** Upper Cord Hook
- E** Power/Surface Selector
- F** Lift-Away™ Button
- G** Wand
- H** Release Wand Button
- I** Dust-Cup Release Latch
- J** Lower Cord Hook
- K** Motorised Floor Nozzle
- L** Brushroll Indicator Light
- M** Headlights
- N** Brushroll Access Buttons

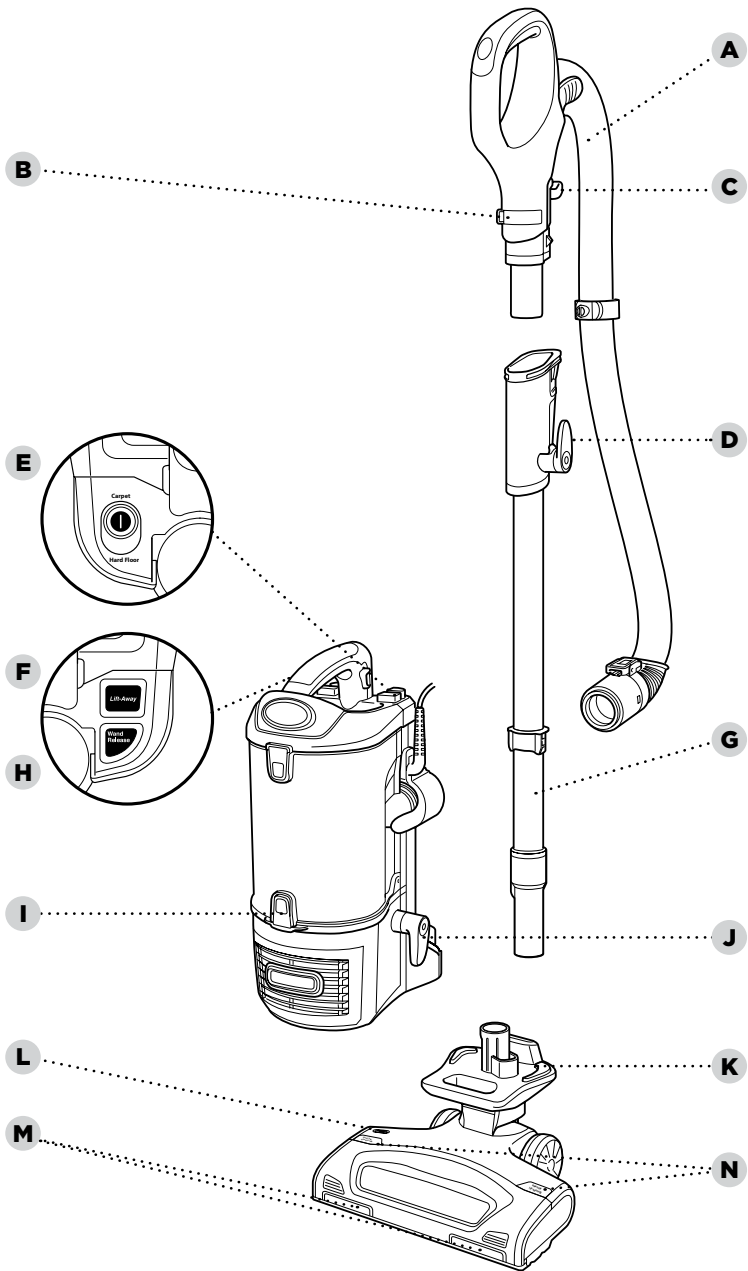

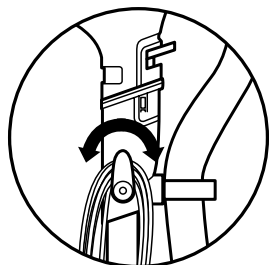

ASSEMBLING YOUR VACUUM

 **TIP:** For quick cord access, rotate upper hook down and remove cord.

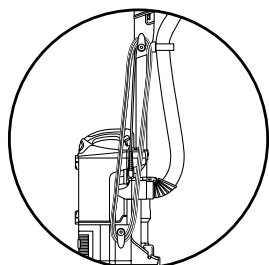

 **TIP:** To store your vacuum, wrap cord around cord hooks.



 **TIP:** Use cord clip located on the side of wand to hold cord in place while vacuuming.

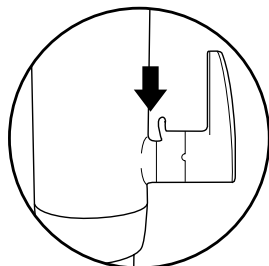

STEP 1

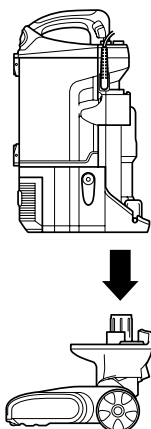

1 Place the pod onto floor nozzle.

STEP 2

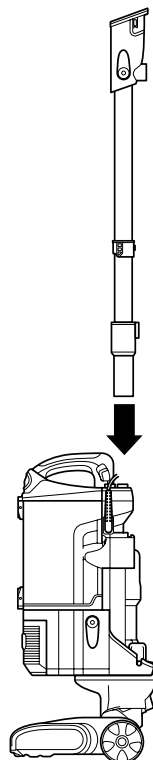

2 Slide wand into base of pod.

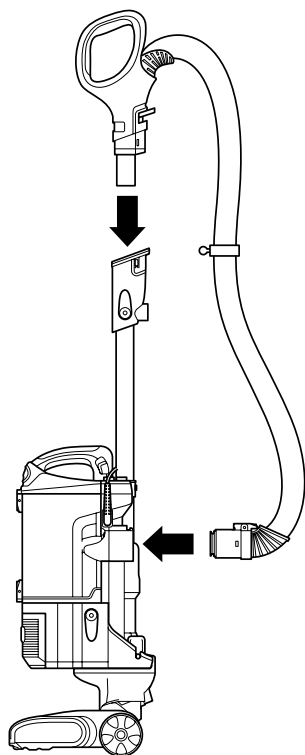
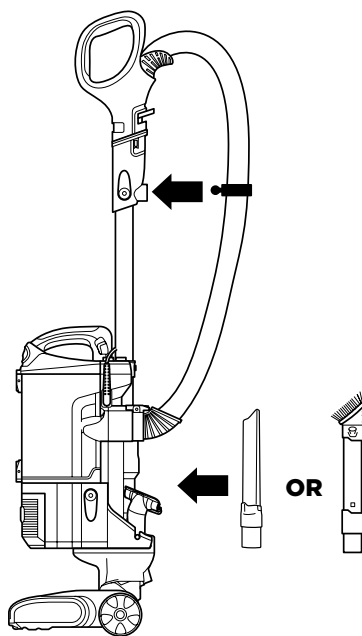
STEP 3**STEP 4**

3 Insert handle into top of wand. Then attach hose to hose connector on base of pod.

4 Insert tools into accessory holder, then secure the hose to the hose clip by pushing the knob into its socket.

USING YOUR VACUUM IN UPRIGHT MODE

⚠ WARNING: DO NOT use to vacuum up drywall dust, fireplace ash, or embers. DO NOT use as an attachment to power tools for dust collection.

WHAT DOES THE BRUSHROLL INDICATOR LIGHT MEAN?

Solid Green

The brushroll is on and working as it should.

Solid Red

There is a jam in the brushroll area. Turn your vacuum off and remove the blockage.

No Light

The vacuum is off. To turn it on, press the POWER button and put in either carpet or hard floor mode.



STEP 1

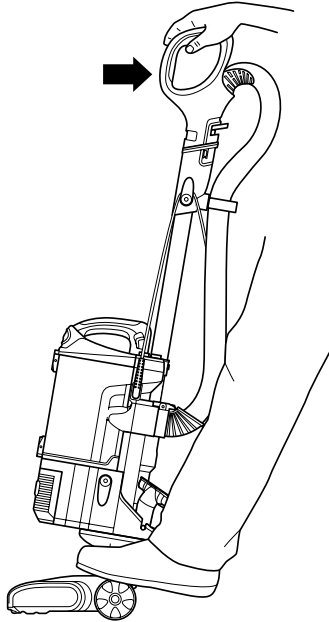

- 1** Plug power cord into outlet. Place foot on floor nozzle and tilt handle back.

STEP 2

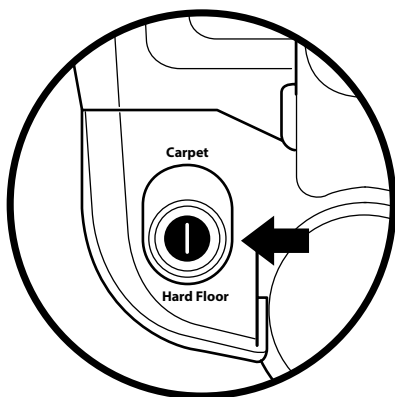

- 2** Slide the power button to Hard Floor setting, then press down to clean hard floor surfaces, area rugs, or above floor. The brushroll will not spin in this mode.

STEP 3

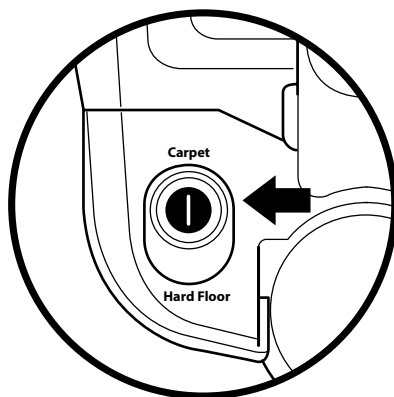

- 3** Slide the power button to Carpet setting and press down to clean carpets. The brushroll will spin fast in this mode for a deep carpet clean.

USING YOUR VACUUM IN ABOVE-FLOOR MODE

THE BENEFITS OF SUCTION CONTROL

Suction Control is a way for you to adjust suction power when you are using different tools or vacuuming different surfaces. For example, if you are feeling resistance while vacuuming thick carpet or upholstery, opening the suction control to MIN will help reduce your push/pull effort.

STEP 1

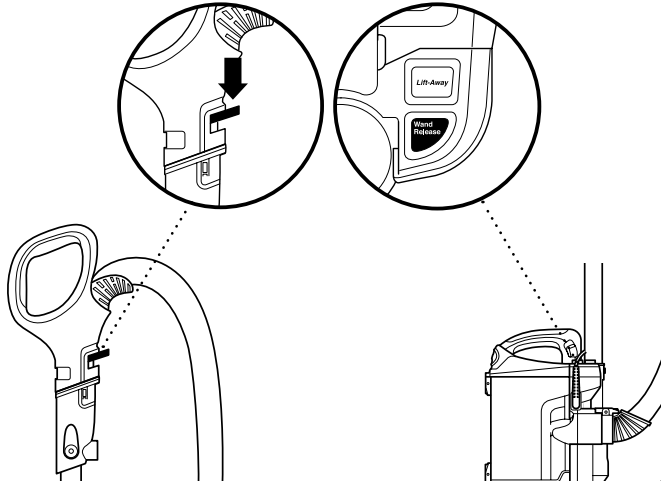

1 To clean within short reach, push handle latch down, then lift the handle up off of the wand.

OR Press Release Wand button on pod when you need to clean with a longer reach.

STEP 2

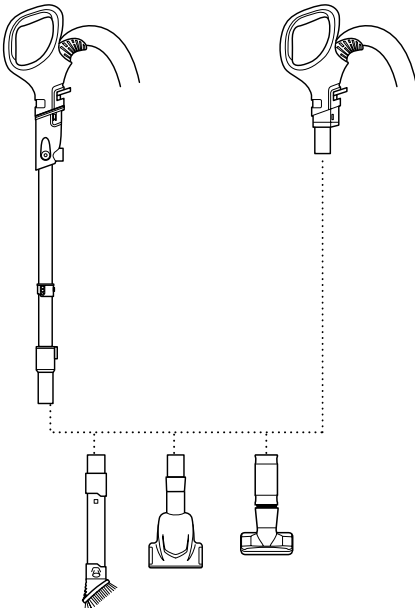

STEP 3

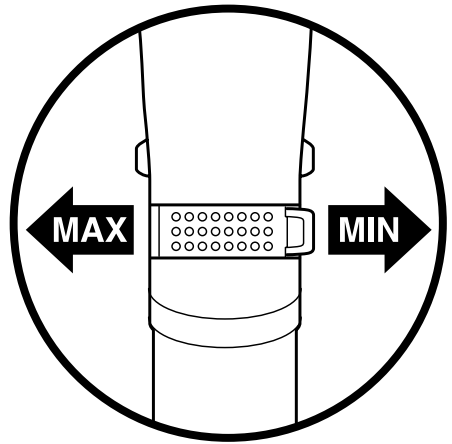

2 Attach desired accessory to the wand or handle.

3 Located at the base of the top handle, Suction Control offers variable suction based on your needs. Slide toward MIN to decrease suction, and slide toward MAX to increase suction.

USING YOUR VACUUM IN LIFT-AWAY™ MODE

⚠ WARNING: Lift-Away mode requires stable footing. Using Lift-Away mode without stable footing may result in personal injury.

💡 TIP: Hold pod in hand when cleaning in Lift-Away mode.

WHAT IS LIFT-AWAY?

Our Lift-Away feature allows you to remove the pod from the floor nozzle to easily clean stairs, above-floor areas with accessories, or hard floors with the hard-floor attachments.

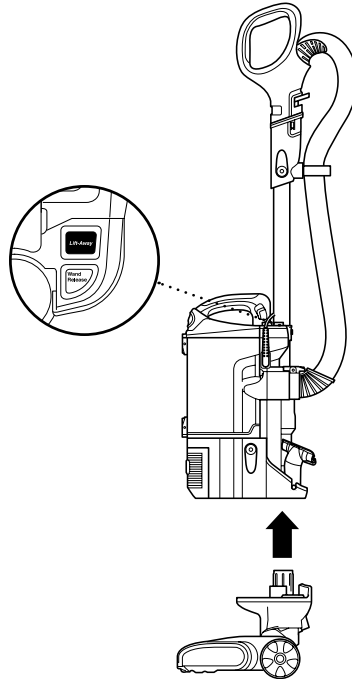

LIFT-AWAY CLEANING

- 1 Press LIFT-AWAY to lift pod off floor nozzle.

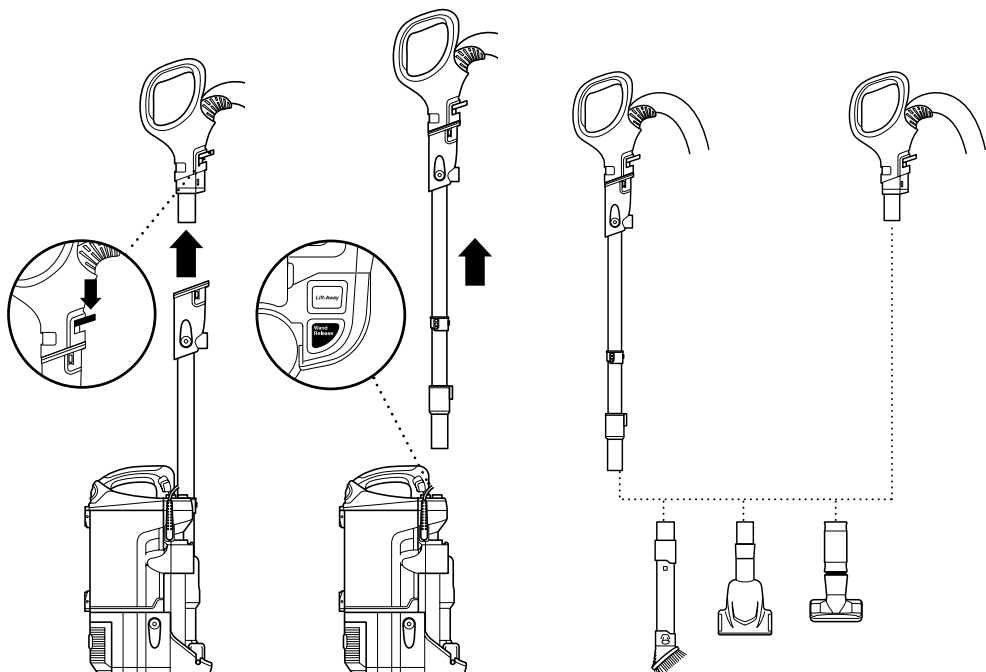

2 To remove the wand from the pod, press the Release Wand button. To release the handle only, push the handle latch down and lift handle up.

3 Attach desired cleaning tool to the end of handle or wand.

COMPATIBLE ACCESSORIES

There are a variety of accessories that are compatible with this vacuum series.

Your Quick Start Guide shows the select accessories that are included with your model.

To purchase additional accessories, go to sharkclean.eu

A Upholstery Tool

Remove pet hair and dust from curtains and other delicate fabrics and upholstery.

B 2 in 1 Crevice Dusting

Combination dusting brush and crevice tool.

C Pet Power Brush

Designed for removal of pet hair and ground-in dirt from carpeted stairs and upholstery.

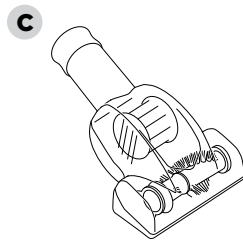
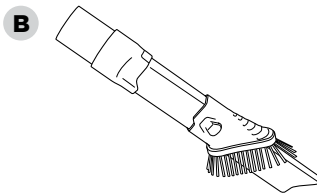
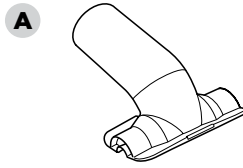

MAINTENANCE

To keep your vacuum's suction power optimal, follow these instructions. Make sure unit is off and cord is unplugged.

⚠ WARNING: To reduce the risk of shock and unintended operation, turn power off and unplug unit before servicing.

Hand wash with water only to prevent damage from cleaning chemicals. Allow ALL filters to dry completely before replacing in the vacuum to prevent liquid from being drawn into electric parts.

★ IMPORTANT: Do not use soap when cleaning the HEPA filter.

RECOMMENDED FILTER CLEANING SCHEDULE:

Pre-Motor Filter Kit

(Foam & Felt)
Clean every 3 months.

Post-Motor Filter

(HEPA)
Clean once a year.

STEP 1

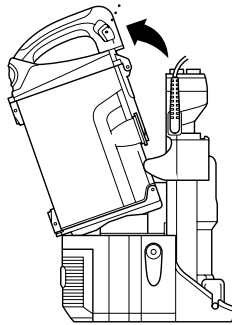
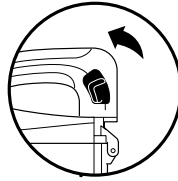

STEP 2

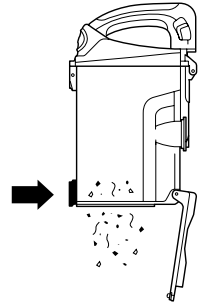

EMPTYING THE DUST CUP

- 1** Lift the dust cup off the pod by pulling up on the release latches on the sides of the dust cup handle.
- 2** Hold dust cup over a trash bin and press the bottom dust-cup release latch.

STEP 3

PRE-MOTOR

Foam filter

Filter frame

Felt filter

POST-MOTOR

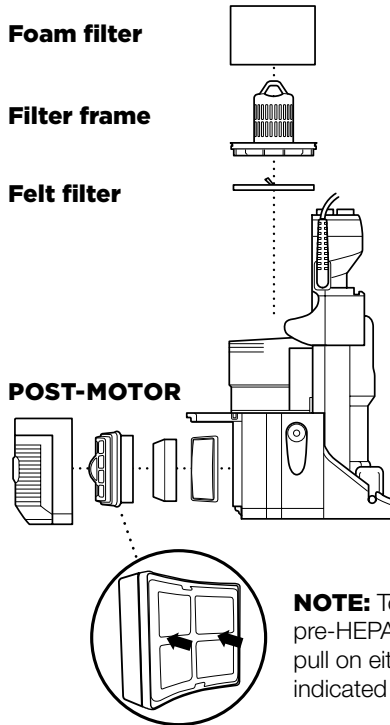
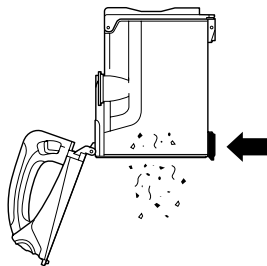

NOTE: To remove the pre-HEPA filter frame, pull on either of the bars indicated by the arrows.

- 3 Press top dust-cup release latch to access dust screen and remove built-up debris as required.

CLEANING THE FILTERS

1 Pre-Motor

(foam and felt):

With the dust cup removed, take out the foam and felt filters, and rinse with water. Tap loose dirt off filters between washes as needed.

2 Post-Motor (HEPA):

To access the HEPA filter, reach under the grill, pull the latch forward, and pull the grill away from the vacuum.

Remove the filter assembly, then remove the black foam filter and plastic frame from the assembly. Rinse both HEPA filter and black foam filter and allow to air dry completely before replacing. To assemble, place the foam onto the HEPA then place the frame on top. Hand wash only.

MAINTENANCE

⚠ WARNING: To reduce the risk of shock and unintended operation, turn power off and unplug unit before servicing.

NOTE: Remove dust cup, wand, and floor nozzle and check all dust-cup intake openings.

NOTE: Remove the handle from the extension wand and check for blockages.

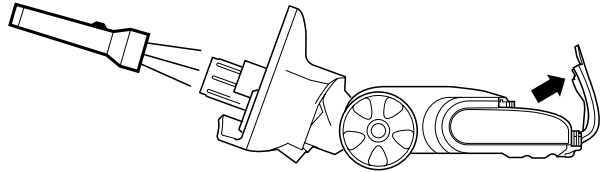

CHECKING FOR BLOCKAGES FLOOR NOZZLE

- 1 Tilt neck of floor nozzle back to straighten the airway and open the Brushroll Garage door. To clear a blockage, insert a long object such as a wooden spoon into the nozzle connector.

STEP 1

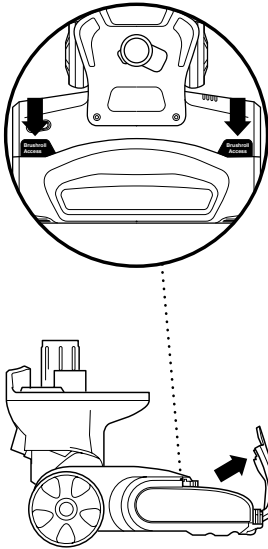

STEP 2

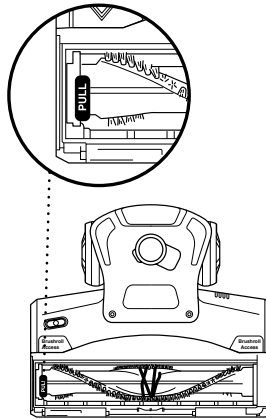

STEP 3

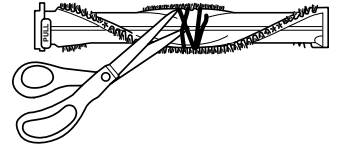

CLEANING THE BRUSHROLL

- 1** Press Brushroll Access buttons to pop up the garage door.
- 2** Lift the brushroll out by the tab on the left side.
- 3** Remove any string, hair or debris that may be wrapped around the brushroll.

TROUBLESHOOTING GUIDE

⚠ WARNING: To reduce the risk of shock and unintended operation, turn power off and unplug unit before servicing.

Vacuum is not picking up debris. No suction or light suction.

(Refer to Maintenance section for more information.)

- Check filters to see if they need cleaning. Follow instructions for rinsing and drying the filters before re-inserting in the vacuum.
- Dust cup may be full; empty dust cup.
- Check hose, hose connections, nozzle, and accessories for blockages; clear blockages if required.
- Remove any string, carpet fibres, or hair that may be wrapped around the brushroll.

Vacuum lifts area rugs.

- Turn off unit to disengage the brushroll. Slide the Power/Surface Selector to the Hard Floor setting to clean with the brushroll off.
- Suction is powerful. Take care when vacuuming area rugs or rugs with delicately sewn edges.
- To minimise suction, refer to Suction Control section for more information.

Brushroll does not spin.

- If Brushroll Indicator Light on the floor nozzle turns red, the brushroll has stopped spinning. Immediately turn off and unplug vacuum and remove blockage before reconnecting and turning vacuum back on.
- With the power on, recline the handle, which will automatically turn on the brushroll.

Brushroll Garage will not close.

- Make sure the brushroll was reinserted correctly with the word "PULL" on the endcap facing up.

Vacuum turns off on its own or Brushroll Indicator Light flashes red.

- This vacuum is equipped with a motor-protective thermostat. If your vacuum overheats, the thermostat will automatically turn the suction motor off. Perform the following steps to restart the thermostat:
 1. Turn vacuum off and unplug it.
 2. Empty dust cup and clean filters (see Maintenance section).
 3. Check for blockages in hose, accessories, and inlet openings.
 4. Allow unit to cool for a minimum of 45 minutes.
 5. Plug in vacuum and turn it on.
 6. Restart the unit in either the Hard Floor or Carpet setting.

Note: If vacuum still does not start, contact Customer Service at 0800 862 0453.

Shark | NINJA WARRANTY TERMS AND CONDITIONS

When a consumer buys a product in the UK, they get the benefit of legal rights relating to the quality of the product (your “statutory rights”). You can enforce these rights against your retailer. However, at Shark we are so confident about the quality of our products that we give you an additional manufacturer’s warranty of up to five years upon registration with Shark. Offer valid only in United Kingdom and Republic of Ireland. These terms and conditions relate to our manufacturer’s warranty only – your statutory rights are unaffected.

The conditions below describe the prerequisites and scope of our warranty. They do not affect your statutory rights or the obligations of your retailer and your contract with them.

Shark Guarantees

A household appliance like a vacuum cleaner constitutes a sizeable investment. Your new machine needs to work properly for as long as possible. The guarantee it comes with is an important consideration - and reflects how much confidence the manufacturer has in its product and manufacturing quality.

Every Shark machine comes with a free parts and labour guarantee. Our customer service helpline (0800 862 0453) is open from 9.00am to 6.00pm Monday - Friday. It’s free to call, and you’ll be put straight through to a Shark representative. You’ll also find online support at sharkclean.eu/uk.

How do I register my extended Shark guarantee?

You can register your guarantee online within 28 days of purchase. To save time, you’ll need the following information about your machine:

- Date you purchased the machine (receipt or delivery note)
- To register online, please visit sharkclean.eu/uk/register-guarantee
- Serial number

IMPORTANT

- Both the 12 months and the extended 4 years guarantee will only cover your product from the date of purchase.
- Please keep your receipt at all times. Should you need to use your extended guarantee we will need your receipt to verify the information you have supplied to us is correct. The inability to produce a valid receipt may invalidate your guarantee.

What are the benefits of registering my free Shark guarantee?

When you register your guarantee we’ll have your details to hand if we ever need to get in touch. You can also receive tips and advice on how to get the best out of your Shark vacuum and hear the latest news about new Shark® technology and launches.

If you register your guarantee online, you’ll get instant confirmation that we’ve received your details.

How long are new Shark machines guaranteed for?

Our confidence in our design and quality control means that your new Shark vacuum cleaner is guaranteed for a total of five years. (12 months plus an extended warranty of 4 years).

What is covered by the free Shark guarantee?

Repair or replacement of your Shark machine (at Shark’s discretion), including all parts and labour. A Shark guarantee is in addition to your legal rights as a consumer.

What is not covered by the free Shark guarantee?

- Blockages – For details of how to unblock your vacuum cleaner, please refer to the Operating Manual.
- Normal wear and tear such as brush bar, fuse, belt, batteries etc.
- Accidental damage, faults caused by negligent use or care, misuse, neglect, careless operation or handling of the vacuum cleaner which is not in accordance with the Shark Operating Manual supplied with your machine.
- Use of the vacuum cleaner for anything other than normal domestic household purposes.
- Use of parts not assembled or installed in accordance with the operating instructions.
- Use of parts and accessories which are not Shark Genuine Components.
- Faulty installation (except where installed by Shark).
- Repairs or alterations carried out by parties other than Shark or its agents.

What happens when my guarantee runs out?

Shark does not design products to last for a limited time. We do appreciate that there may be a desire for our customers to want to repair their vacuum cleaners after the warranty has elapsed. In this case please contact our free phone customer service help line and ask about our out warranty program, on 0800 862 0453.

Where can I buy genuine Shark spares and accessories?

Shark spares and accessories are developed by the same engineers who developed your Shark vacuum. You’ll find a full range of Shark spares, replacements and accessories for all Shark machines at sharkclean.eu.

Please remember that using non-Shark spares invalidates your guarantee.



Euro-Pro Europe Limited
Unit 15 Mariner Court
Calder Business Park
Wakefield, West Yorkshire, UK
Freephone 0800 862 0453
www.sharkclean.eu

Illustrations may differ from actual product. We are constantly striving to improve our products; therefore the specifications contained herein are subject to change without notice.

Shark is a registered trademark of Euro-Pro Europe Limited

Lift-Away is a trademark of Euro-Pro Europe Limited

© 2017 Euro-Pro Europe Limited
NV601UK_Series_IB_170928
PRINTED IN CHINA