

BUSH

Instruction manual

FDC60B
FDC60W



You'll soon be enjoying your new Freestanding Cooker

It all begins here, with your instructions. Don't worry, there's nothing too technical coming up. Just simple, step-by-step guidance to get you up and running quickly. Sound good? Then let's get started.

Help and Guidance

We're here to help you get the most from your Freestanding Cooker. Should you require any guidance, a simple solution can often be found online at:

www.bush-support.com

If you still require further assistance, call one of our experts on **0345 257 7271**.

Issue-1, 09/04/2026

Contents

1 Safety information

Safety information 6

2 Getting to know your Freestanding Cooker

Overview 11

Accessories 12

3 Installing your Freestanding Cooker

Installation requirements 14

Electrical connection 15

4 Using your Freestanding Cooker

Control panel 18

Oven functions 19

General oven and cooking tips 23

Practical Cooking Advice 23

Using the Ceramic Zones of your cooker 25

5 Care and Maintenance

Cleaning 28

Replacing oven lamps 29

How to remove the oven doors 29

Technical specification 30

Energy fiche 31

Circuit Diagram 32

6 Product support

Troubleshooting 34

Help and assistance 35

Declaration of conformance to product standards 36

Disposal 36

Guarantee 37



Safety information

1





Safety information

Important - Please read these instructions fully before installing or operating

INSTALLATION WARNINGS

IMPORTANT: Prior to Installation ensure that the local supply conditions (electricity voltage and frequency) are compatible with the requirements of your freestanding cooker.

IMPORTANT: Carefully unpack and examine the appliance for any damage. If you think there is a defect, do not use the appliance and contact Bush Product Support on 0345 257 7271. Packaging materials should be collected together and disposed of immediately as they may be harmful to children.

IMPORTANT: Keep the electrical cable (not supplied) of your freestanding cooker away from the hot areas of your appliance, do not let the cable touch the appliance. Keep the cable away from sharp edges and heated surfaces.

IMPORTANT: Ensure that the electric supply cable is not trapped or damaged during installation.

IMPORTANT: In the event that the cable connecting your freestanding cooker becomes damaged, it must be replaced by a suitably qualified person. This cable must not be replaced by an unauthorised person.

IMPORTANT: Protect your freestanding cooker against atmospheric effects. Do not expose your cooker to effects such as sun, rain, snow etc.

IMPORTANT: The materials surrounding the appliance (cabinets) must be able to withstand a minimum temperature of 100°C.

IMPORTANT: When using your oven for the first time your cooker may give off an unusual odour from the heating elements and

insulation materials. To eliminate this odour run the oven at 250°C / MAX for 40-60 minutes with the oven empty.

IMPORTANT: The supply cable must be positioned or protected so that its temperature does not exceed the room temperature by more than 50°C at any point along its length.

IMPORTANT: Ensure that the type of cord to be used, taking into account the temperature of the rear surface of the appliance.

IMPORTANT: The appliance must be connected to fixed wiring that incorporates a means of disconnection in accordance with the relevant wiring regulations.

WARNING: Before obtaining access to terminals, all supply circuits must be disconnected.

IMPORTANT: Make sure the oven control knobs are all in the off position when not in use.

IMPORTANT: If you do not intend to use your builtin oven for a long period of time then turn off the electric supply to the oven.



Safety information

Important - Please read these instructions fully before installing or operating

DURING USAGE

IMPORTANT: This appliance can be used by children aged from 8 years and above and persons with reduced physical, sensory or mental capabilities or lack of experience and knowledge if they have been given supervision or instruction concerning use of the appliance in a safe way and understand the hazards involved. Children shall not play with the appliance. Cleaning and user maintenance shall not be made by children without supervision.

WARNING: During use the appliance becomes hot. Care should be taken to avoid touching heating elements inside the oven.

WARNING: The appliance and its accessible parts become hot during use. Care should be taken to avoid touching heating elements. Children less than 8 years of age shall be kept away unless continuously supervised.

WARNING: Unattended cooking on a hob with fat or oil can be dangerous and may result in a fire. NEVER try to extinguish a fire with water, but switch off the appliance and then cover flame e.g. with a lid or a fire blanket.

CAUTION: Do not allow children in the kitchen when cooking or after, as the parts may still be hot. Many parts of the cooker will become hot and present a considerable hazard to children.

CAUTION: When the cooker is hot never touch the oven glass by hand or with tools.

CAUTION: Before starting to use your appliance, ensure curtains, paper or flammable items are kept away from your appliance. Do not keep flammable materials inside of or around your cooker.

CAUTION: Take care when closing the oven door that there is nothing obstructing it from closing as this may break the glass door.

IMPORTANT: When using the grill the oven door must be kept closed.

IMPORTANT: This appliance is not intended to be operated by means of external timer or separated remote-control system.

CAUTION: The cooking process has to be supervised. A short time cooking process has to be supervised continuously.

IMPORTANT: Ensure the appliance is placed on a base, measures have to be taken to prevent the appliance slipping from the base.

IMPORTANT: This appliance must not be installed behind a decorative door in order to avoid overheating.

WARNING: Use only hob guards designed by the manufacturer of the cooking appliance or indicated by the manufacturer of the appliance in the instructions for use as suitable or hob guards incorporated in the appliance. The use of inappropriate guards can cause accidents.

IMPORTANT: When the door of the oven is open, do not hang or lean anything on it. You may unbalance your appliance or damage the door or door hinges.

IMPORTANT: Do not hang towels, dishcloths or clothes from the cooker or its handles.



Safety information

Important - Please read these instructions fully before installing or operating

GENERAL SAFETY WARNINGS

IMPORTANT: This appliance has been designed for non-professional, domestic use only. Do not use this oven for commercial use or any other application e.g room heating.

WARNING: Danger of fire: do not store flammable items on or near the cooking surfaces or inside the oven.

IMPORTANT: Do not try to lift or move this appliance by pulling on the door handle.

WARNING: Ensure that the appliance is switched off before replacing the lamp to avoid the possibility of electric shock.

IMPORTANT: Your appliance is produced in accordance with all applicable local and international standards and regulations.

IMPORTANT: Maintenance and repair work must only be performed by authorised service technicians. Installation and repair work that is carried out by unauthorised technicians is dangerous and could invalidate your guarantee.

WARNING: Do not clean your oven with a steam cleaner.

WARNING: When using the steam-assisted cleaning function, oven surfaces may become hotter than usual. Keep children away from the appliance.

SERVICE

IMPORTANT: Any electrical work required to do the servicing of the appliance should be carried out by qualified electrician or competent updated.

IMPORTANT: This product must be serviced by an authorized Service agent, and only genuine spare parts must be used. Installation by anyone other than an authorized agent may cause your warranty to be void.

IMPORTANT: Do not attempt to repair the appliance yourself. Contact the Customer Helpline: 0345 247 7271.

CLEANING AND MAINTENANCE

IMPORTANT: Always turn the appliance off before operations such as cleaning or maintenance. You can do this by switching the freestanding cooker off using the cooker isolation switch

IMPORTANT: Do not remove the control knobs to clean the control panel.

WARNING: Do not use harsh abrasive cleaners or sharp metal scrapers to clean the oven door glass since they can scratch the surface, which may result in shattering of the glass.

SYMBOL

EXPLANATION



Caution, possibility of tilting



Anti-tip restraints



Read operator's manual

If you require any technical guidance or find that your product is not operating as intended, a simple solution can often be found in the **Troubleshooting** section of these instructions,

Getting to know your Freestanding Cooker

2



Getting to know your Freestanding Cooker

You'll be up and running in no time

Ready? Let's begin...

Please read these instructions carefully. They contain important information which will help you get the best from your freestanding cooker and ensure safe and correct installation and operation.

If you require any further assistance, our technical experts are happy to help. For full details, refer to the product support section at the end of these instructions.

If you require any technical guidance or find that your product is not operating as intended, a simple solution can often be found in the **Troubleshooting** section of these instructions,

Getting to know your Freestanding Cooker

You'll be up and running in no time

Overview

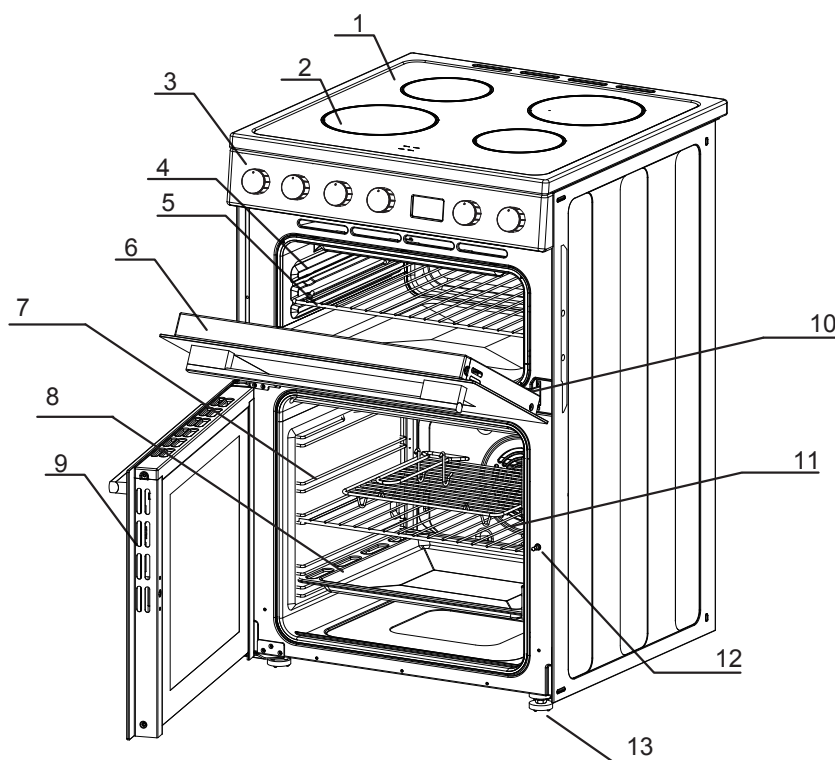

1. Hob
2. Cooking zone
3. Control Panel
4. Shelf positions
5. Wire Shelf
6. Oven Door
7. Shelf positions
8. Baking tray
9. Oven Door
10. Hinge
11. Wire Shelf
12. Door lock
13. Anti slip feet

Cooking zone

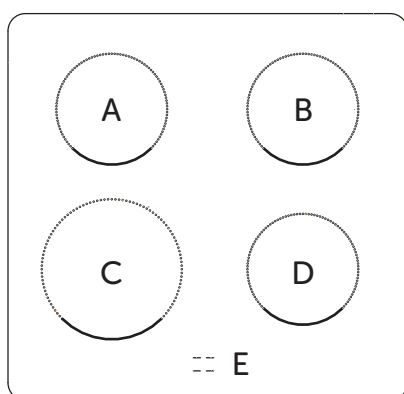

- A. Single cooking zone: 1200W
- B. Single cooking zone: 1200W
- C. Single cooking zone: 1800W
- D. Single cooking zone: 1200W
- E. Residual heat warning indicators

Residual heat warning indicators (E)

After the cooking zone has been switched off, the residual heat warning indicator lights up to warn that the surface is still hot. Do not touch the cooking zone while the indicator is illuminated. The indicator will switch off automatically once the surface has cooled to a safe temperature.

Getting to know your Freestanding Cooker

You'll be up and running in no time

Accessories

1.

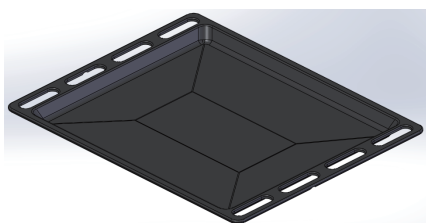

Baking tray x 1

2.

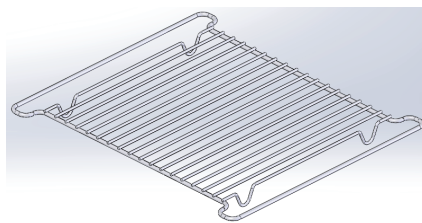

Grill insert x 1

3.

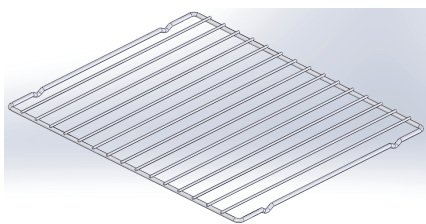

Chrome shelf x 2

4.

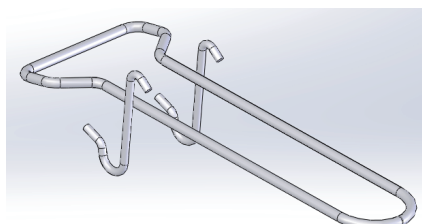

Grill pan handle x 1

If you require any technical guidance or find that your product is not operating as intended, a simple solution can often be found in the **Troubleshooting** section of these instructions,

Installing your Freestanding Cooker

3



Installing your Freestanding Cooker

Bringing it all together

Installation requirements

THIS COOKER MUST BE INSTALLED BY A QUALIFIED INSTALLER IN ACCORDANCE WITH LOCAL REGULATIONS



IMPORTANT: CONTACT AN AUTHORISED SERVICE AGENT FOR INSTALLATION OF YOUR OVEN!

Positioning

1. Make sure that there are no combustible or flammable materials, such as curtains, in the vicinity of the installation.
2. Furniture and cabinets surrounding the cooker must be of material resistant to temperatures greater than 100°C.
3. Surrounding furniture, cabinets and extractor fans should be positioned in accordance with the diagram shown in the figure
4. There must be at least 2cm of free space between the back wall and the rear of the appliance to allow for ventilation and air circulation.
5. If fitted, the extractor fan must be at least 65cm above the hotplates. If no fan is fitted the minimum distance between the hotplates and any cabinet or other structure must be 75cm.

First Use

IMPORTANT: When using your oven for the first time your cooker may give off an unusual odour from the heating elements and insulation materials. This is normal for new cookers. To eliminate this odour run the oven at 250°C / MAX for 40-60 mins with the oven empty.

Unpacking

Carefully unpack and examine the appliance for any damage. If you think there is a defect, do not use the appliance and contact Product Support on 0345 257 7271.

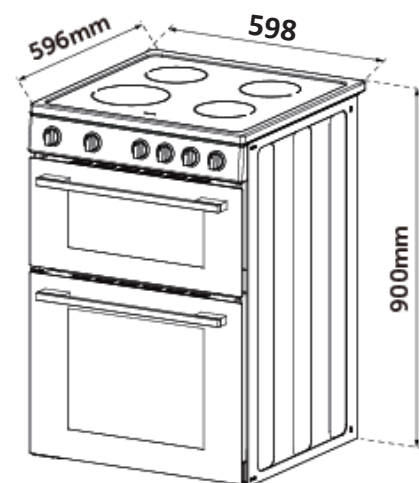
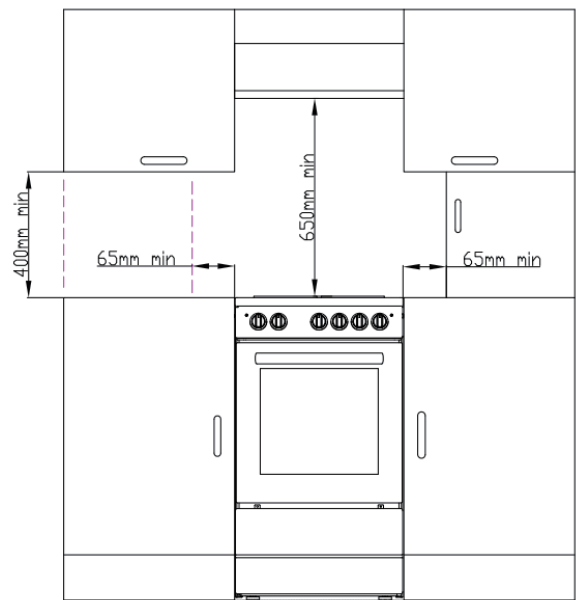

If you require any technical guidance or find that your product is not operating as intended, a simple solution can often be found in the **Troubleshooting** section of these instructions,

Installing your Freestanding Cooker

Bringing it all together

Levelling feet

The height and level of the appliance can be adjusted by rotating the feet located underneath the appliance at each corner. Rotate the feet to decrease or increase the height.

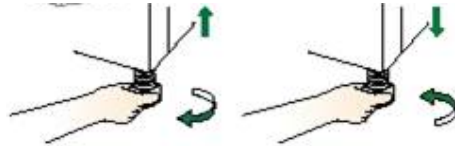
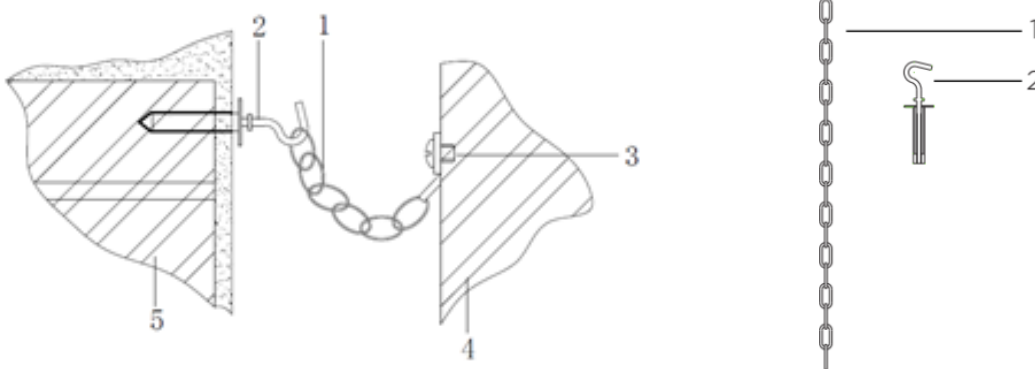

Figure 1.

Safety chain

The appliance must be secured against overbalancing by using the supplied two safety chains on your oven.

Fasten hook (1) by inserting a wall plug into the kitchen wall (5) and connect safety chain (3) to the hook via the locking mechanism (2).



- 1 Safety chain(supplied and mounted to oven)
- 2 Stability hook
- 3 Chain attachment for the rear cooker
- 4 Rear of the cooker
- 5 Kitchen wall

Installing your Freestanding Cooker

Bringing it all together

Electrical connection correction

IMPORTANT: Electrical connections must be carried out by a suitably qualified person and in accordance with all relevant local building and installation regulations.

Fitting on a Power Supply Cable

Connecting appropriate power supply terminal board/ connector block:

- Using a screwdriver, pry open tabs of the Terminal board cover.
- Remove the wire clamp screw.
- Fasten the wires beneath the corresponding screw heads.
- Fasten cable clamp and close the cover of the terminal board.
- The ac power supply should be 220-240 V, 50/60 Hz. For electric cookers, the minimum 32A fuse, or at least 32A a distribution circuit breaker.

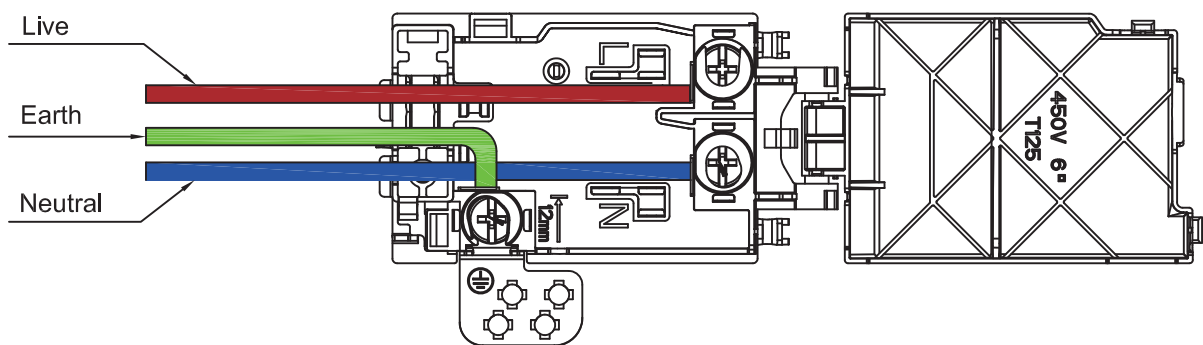

Warning: Connect the power cord must be in accordance with the instructions listed in the table below

Wire cross-sectional area(mm ²)	L	N	E
Connectionmode			
1N-	Min4	Min4	Min4

Connecting the supply cable to the mains

Install an approved circuit breaker with a minimum contact opening of 3 mm, between the appliance and the mains fuse box. The circuit breaker should be sized according to the load and should comply with current regulations (the earth wire should not be interrupted by the circuit breaker).

The supply cable should be positioned so that it does not reach a temperature of more than 50 °C with respect to the room temperature, anywhere along its length. Before switching fuse ON in meter-box check:

- Earth continuity. The electrical safety of this appliance can only be guaranteed if the cooker is correctly installed and earthed, in compliance with regulations on electrical installations.
- The electrical capacity of the system and sockets will support the maximum power of the appliance, as indicated on the data plate

If you require any technical guidance or find that your product is not operating as intended, a simple solution can often be found in the **Troubleshooting** section of these instructions.

Using your Freestanding Cooker



Using your Freestanding Cooker

Getting the most from your appliance

Control panel

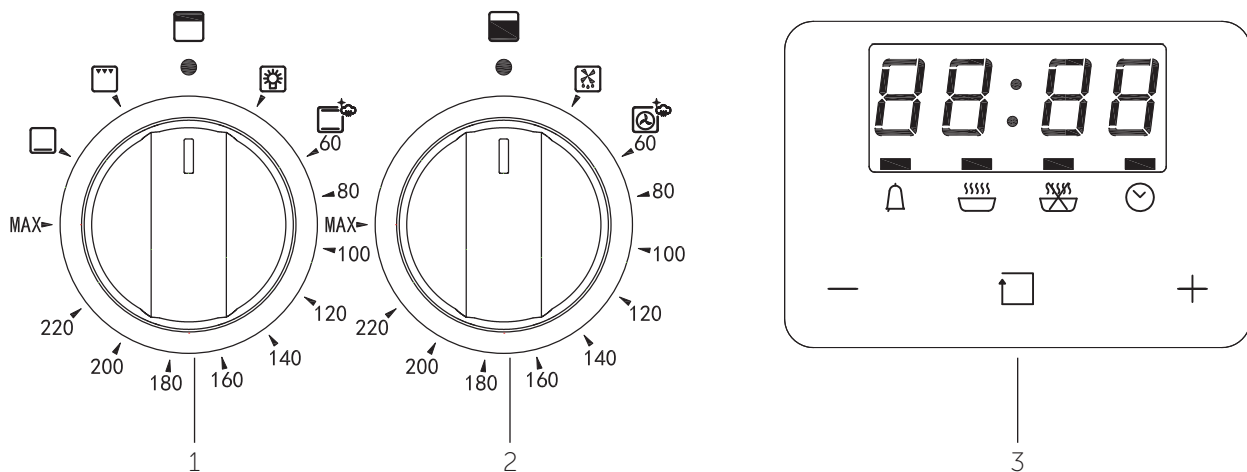

1. Upper Oven Temperature/Function Selector

- Sets temperature/mode for oven.

2. Lower Oven Temperature/Function Selector

- Sets temperature/mode for oven.

3. Programmable Timer (For Lower Oven Only)

- Sets cooking duration.

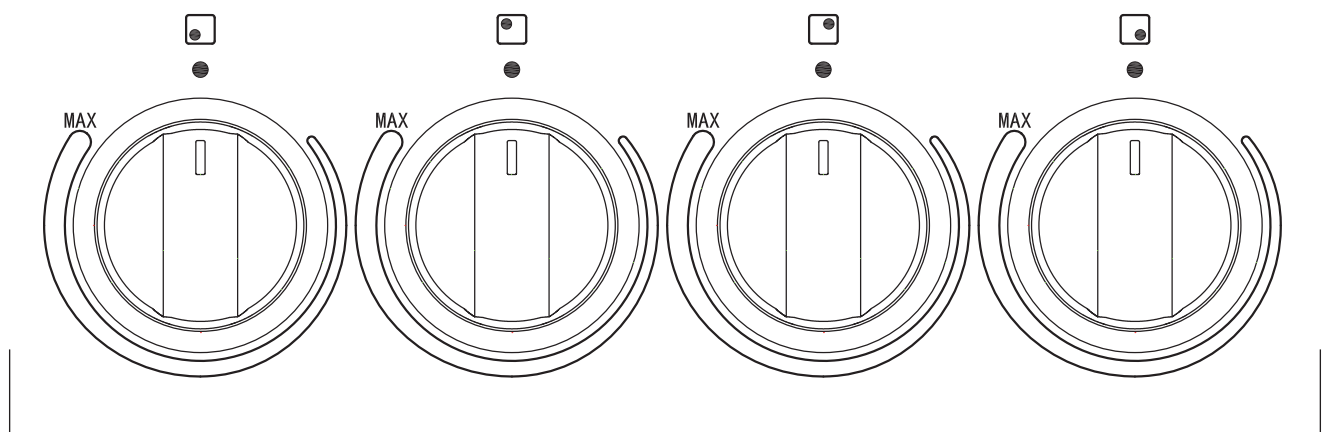

4. Ceramic Control Knob

- Can be rotated in either direction

If you require any technical guidance or find that your product is not operating as intended, a simple solution can often be found in the **Troubleshooting** section of these instructions.

Using your Freestanding Cooker

Getting the most from your appliance

Oven functions



Oven light



Grill



Top & Bottom element / Steam-assisted Cooking and Cleaning



Bottom element



Defrost mode



Fan Baking / Steam-assisted Cooking and Cleaning

Oven light

The oven light will operate on all oven functions.

Grill

The top central heating elements come on. The extremely high and direct temperature of the grill makes it possible to brown the surface of meats and roasts while locking the juices in to keep them tender. The grill is also highly recommended for dishes that require a high temperature on the surface: beef steaks, veal, rib steak, fillets, hamburgers etc.

Top & Bottom element

Hot air comes from the upper and lower element in the oven. This is the conventional cooking method that cooks your food equally. Joints of meat will benefit using this cooking function, and any roasted items.

Bottom element

Bottom element cooking is used for foods that typically need cooking from the underneath side. Cakes and bread as an example can be cooked using this function mode.

Defrost mode

When set to 'Defrost' mode, the fan located at the back of the oven circulates room temperature air around the food. This is recommended for the defrosting of all types of food, but in particular for delicate types of food which do not require heat, for example: ice cream cakes, cream or custard desserts, fruit cakes, etc. By using 'Defrost' mode, the defrosting time is approximately halved.

Fan Baking

When set to Baking mode, the fan element and the fan operate providing a delicate heat distributed uniformly throughout the oven. This mode is ideal for baking and cooking delicate foods on multiple shelves, especially cakes that need to rise such as cream puffs and for certain tartlets, sweet or savory biscuits, savory puffs, swiss rolls and small portions of vegetables, etc.

OFF Position

Switch off the oven by turning the oven selector to the top-centre OFF position.

Using your Freestanding Cooker

Getting the most from your appliance

Steam-assisted Cooking

You can use this function to add extra browning to pizza bases, pies and cakes, or to cook different foods using a combination of bottom heat and steam.

If you wish, you can follow the steps below:

1. Add approximately 100 ml of water in the bottom cavity (Fig.1). The approximate capacity of the cavity can be up to 200 ml.

NOTE: The capacity may vary depending on the oven model.

2. Activate the Steam Assist mode  and select a temperature of 200°C. Approximate cooking time: 20 minutes.

3. Be sure to remove any excess water from the oven cavity at the end of the cooking process.

NOTE: You can adjust the amount of water, the cooking time and the temperature according to the needs of the food to be prepared.

WARNING: Make sure that the interior is completely cool before removing excess water. Risk of burns.

NOTE: The graphics in this manual are schematic representations and may not exactly match the device.

Steam-assisted Cleaning

This function is intended only for removing easily cleanable food residues from the inside of the oven.

It is not suitable for stubborn stains. This function can only be used when the oven is cold.

1. Make sure to empty the oven before cleaning it with this method.

2. Prepare a solution of water (85%), white vinegar (10%), and dish detergent (5%) and spray generously on the door, side walls, and rear wall of the oven cavity Fig 2.

3. Pour 40ml of water into the base of the cavity as shown in Fig 1.

4. Close the door. Select the steam-assisted cleaning function and set the temperature to 130°C.

5. Turn off the oven after 18 minutes.

6. Allow the oven to cool down to a safe temperature before wiping it with a damp cloth.

Fig 1



Fig 2

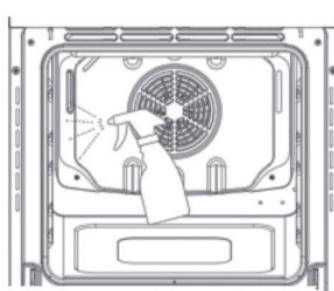

Using your appliance for the first time

The first time you use your appliance, we recommend that you set the temperature setting to the highest mark. Set the cooking mode selection knob to a cooking mode and leave the oven on for about half an hour with nothing in it and the oven door shut. Then, open the oven door and allow the oven to cool. Any odour that may be detected during this initial use is due to the evaporation of substances used to protect the oven during storage.

Using your Freestanding Cooker

Getting the most from your appliance

Programmable timer (applicable to the lower oven only)

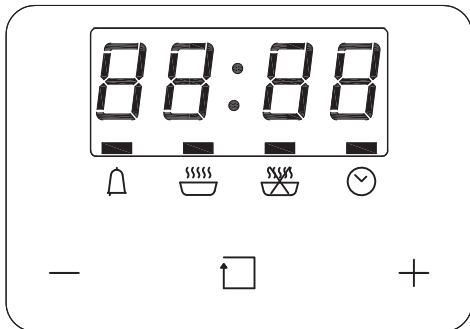

- △ Sets the countdown timer
- ☪ Sets the cooking duration.
- ☪ Sets the cooking end time
- 🕒 Sets the current time.
- Decrease the selected setting values
- ☐ Used to select the timer, cooking duration, end time, and clock time
- + Increase the selected setting values.

This model has a digital display, 24hr clock with 3 control buttons. When the power is connected, the screen displays '12:00'.

Clock setting

Set the time before you start using the oven.

When connecting the appliance to the electrical power supply for the first time or after a main power failure, the "🕒" indicator will flash

Press the "+" or "-" button to set the time. After approximately five seconds the indicator light will stop flashing and the display will show the set time.

To change the time subsequently, press the function selection button "☐" until the "🕒" indicator starts flashing, then press the "+" or "-" button to set the correct time.

Manual cooking procedure (without using the cooking programmer)

To switch on and use the oven in manual mode (disabling the cooking programmer), simply set the Oven Temperature/Function Selector to the required position.

Note: To switch off the oven, turn the selector to the top-centre OFF position.

Timer cooking procedure

-Cooking time setting

1A - Set the cooking duration (max 10 hours). Press the function selection button "☐" repeatedly until the "☪" indicator starts flashing, then press the "+" or "-" button to set the cooking duration;

2A - Switch on the oven immediately, the "☪" indicator will start flashing. When cooking is ended the oven will automatically switch off, the "☪" indicator will flash and the alarm will sound. To mute the alarm press any key, after one minute the alarm will switch off automatically.

- Cooking end time setting

1B- Set the cooking end time (up 23:59 max). Press the function selection button "☐" repeatedly until the "☪" indicator starts flashing, then press the "+" or "-" button to set the cooking end time.



2B- Switch on the oven immediately; the "☪" indicator will start flashing. When the set time is reached the oven will switch off automatically, the "☪" indicator will flash and the alarm will sound. To mute the alarm press any key, after one minute the alarm will switch off automatically.



Using your Freestanding Cooker

Getting the most from your appliance

Timer setting

The longest settable time interval is 23 hours and 59 minutes.

1. To set the timer, press the function selection button "  " repeatedly until the "  " indicator starts flashing, then press the "+" or "-" button to set the required time, which will be shown on the display;

2. After having set the time (hours, minutes) the "  " indicator will flash and the countdown will start. Once the set time has been reached the "  " indicator will flash and the alarm will sound. To mute the alarm press any key after one minute the alarm will switch off automatically.

Using your Freestanding Cooker

Getting the most from your appliance

General oven and cooking tips

General Oven Tips

The wire shelves should always be pushed firmly to the back of the oven.

Baking trays with food cooking on them should be placed level with the front edge of the oven's wire shelves. Other containers should be placed centrally. Keep all trays and containers away from the back of the oven, as over-browning of the food may occur. For even browning, the maximum recommended size of a baking tray is 340 mm (13½") by 340 mm (13½").

When the oven is on, do not leave the door open for longer than necessary, otherwise the knobs may get very hot.

- Always leave a "finger's width" between dishes on the same shelf. This allows the heat to circulate freely around them.
- To reduce fat splashing when you add vegetables to hot fat around a roast, dry them thoroughly or brush lightly with cooking oil.
- Where dishes may boil and spill over during cooking, place them on a baking tray.

Practical Cooking Advice

The oven offers a wide range of alternatives which allow you to cook any type of food in the best possible way. With time you will learn to make the best use of this versatile cooking appliance and the following directions are only a guideline which may be varied according to your own personal experience.

Preheating

The oven must be preheated (this is generally the case when cooking leavened foods).

Once the food has been placed in the oven, the most appropriate cooking mode can then be selected.

Using the Grill

Use the grill mode  placing the food under the center of the grill (situated on the 3rd or 4th rack from the bottom) due to the central part of the top heating element being active.

Please use the grill pan set provided ensuring that there is no unwanted spillages formed inside your oven. When using this mode, we recommend you set the thermostat to the highest setting. However, this does not mean you cannot use lower temperatures, simply by adjusting the thermostat knob to the desired temperature.

When using this mode, we advise you to set the thermostat to 200°C, as it is the most efficient way to use the grill, which is based on the use of infrared rays.

Baking Cakes

When baking cakes, always place them in a preheated oven. Make sure you wait until the oven has been preheated thoroughly (the pilot lamp will turn off). To prevent cake from dropping/sinking – do not open the oven door during baking.

Pastry is too dry

Increase the temperature by 10°C and reduce the cooking time.

Pastry dropped

Use less liquid or lower the temperature by 10°C.

Pastry is too dark on top

Place it on a lower rack, lower the temperature, and increase the cooking time.

Cooked well on the inside but sticky on the outside

Use less liquid, lower the temperature, and increase the cooking time.

The Pastry sticks to the pan

Grease the pan well and sprinkle it with a dusting of flour or use greaseproof paper.

Use a lower temperature setting. It is not necessary to remove the food from all the racks at the same time. **Cooking**

Fish and Meat

When cooking white meat, fowl and fish, use temperature setting from 180°C to 200°C.



For red meat that should be well done on the outside while tender and juicy in the inside, it is a good idea to start with a high temperature setting (200°C - 220°C) for a short time, then turn the oven down afterwards.

In general, the larger the roast, the lower the temperature setting. Place the meat on the center of the grid and place the dripping pan beneath it to catch the fat.

Make sure that the grid is inserted so that it is in the center of the oven. If you would like to increase the amount of heat from below, use the low rack heights. For savory roasts (especially duck and wild game), dress the meat with lard or bacon on the top.

Using your Freestanding Cooker

Getting the most from your appliance

Selector knob setting	Food to be cooked	Weight (in kg)	Cooking rack position from bottom	Preheating time (Minutes)	Thermostat knob setting	Cooking time (Minutes)
Convection 	Duck	1	3	15	200	65-75
	Roast veal or beef	1	3	15	200	70-75
	Pork roast	1	3	15	200	70-80
	Biscuits (short pastry)	-	3	15	180	15-20
	Tarts	1	3	15	180	30-35
Grill 	Soles and cuttlefish	1	4	5	Max	8-10
	Squid and prawn kebabs	1	4	5	Max	6-8
	Cod filet	1	4	5	Max	10
	Grilled vegetables	1	3/4	5	Max	10-15
	Veal steak	1	4	5	Max	15-20
	Cutlets	1	4	5	Max	15-20
	Hamburgers	1	4	5	Max	7-10
	Mackerels	1	4	5	Max	15-20
	Toasted sandwiches	-	4	5	Max	2-3
	Veal on the spit	1	4	15	200	30-40
	Chicken on the spit	1.5	4	15	200	30-40
Lamb on the spit	1	4	15	200	30-40	

NB: cooking times are approximate and may vary according to personal taste. Shelf position is counted from the bottom shelf up. Bottom shelf position is 1. Turn down temperatures shown

If you require any technical guidance or find that your product is not operating as intended, a simple solution can often be found in the **Troubleshooting** section of these instructions.

Using your Freestanding Cooker

Getting the most from your appliance

Using the ceramic cooking zones of your cooker

- Do not use pots and pans which are unsteady, as these could overbalance.
- Do not use mats, heat diffusers or wok stands. These will cause a temperature build-up which can damage the cook top.
- Do not let cooking pots over spill, this could leave a mark and residue on the glass.

Ceramic hotplate

- Do not use if the ceramic glass top is cracked or broken.
- Do not leave aluminium foil on the hot ceramic hotplates(permanent damage will occur)

Choosing Cooking Pots

Look at this diagram below which shows you which pans to use on the hotplates and which pans should not be used.

- Always use pots and pans with flat bottoms. Uneven or thin bottoms will waste energy and cook slowly.
- Always use pots and pans which are slightly larger than the hotplate. Small pans waste energy.
- Always put dry pots and pans on the hotplates.

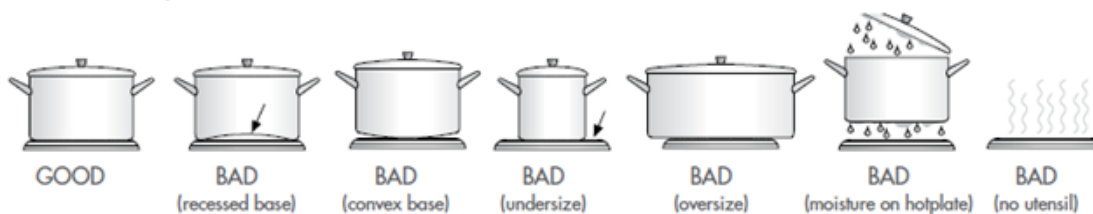



Care and maintenance

5



Care and maintenance

Looking after your appliance

Cleaning

WARNING! Isolate the power supply to the appliance and make sure that the cooker is cool.

Before cleaning your cooker or performing maintenance, make sure that both Oven Temperature/Function Selectors are turned to the top-centre OFF position. To extend the life of your cooker, it must be cleaned frequently. The inside of the cooker should preferably be cleaned immediately after use, when it is still warm (but not hot) with warm water and soap. The soap should be rinsed away and the interior dried thoroughly. Avoid using abrasive detergents, scourers, acidic cleaners such as lime scale remover, etc, as these could damage the enamel, and can result in development of rust and corrosion. If stains are particularly tough to remove, use cleaners specifically recommended to clean cookers and follow the instructions provided with the cleaner.

Never use steam cleaner for cleaning inside the cooker.

Do not clean using caustic creams, abrasive cleaning powders, thick wire wool or hard tools. Enamelled parts of the cooker can be damaged if excess cleaning liquids are not immediately removed.

After cleaning the interior parts of the cooker with a soapy cloth, rinse it and then dry thoroughly with a soft cloth.

Clean the glass surfaces with special glass cleaning agents.

Never use flammable agents like acid, thinner or petrol when cleaning your appliance.

Do not clean your cooker with a steam cleaner.

Do not wash any part of your cooker in a dishwasher.

Enamelled Parts:

In order to keep enamelled parts as new, it is necessary to clean them frequently with mild warm soapy water and then dry with a cloth. Do not wash them while hot and never use abrasive powders or abrasive cleaning materials. Do not leave anything spilled onto enamelled parts for long periods of time.

Ceramic Glass:

The ceramic glass should be regularly cleaned, always wipe clean immediately after each use once the residual heat warnings have switched off – DO NOT clean when hob is still hot. Smudges from pans with an aluminum bottom can be easily cleaned off with a cloth dampened in vinegar. Remove any burnt residues immediately after cooking, rinse with water and wipe dry with a clean cloth. Never use abrasive or corrosive detergents, cleaning powders, oven sprays, spot-removers, steel wool or scourers.

Care and maintenance

Looking after your appliance

Replacing the oven lamps

Replacement lamps are available from our support team. Please call 0345 257 7271.

Light source shall be replaced by professional.

WARNING: Ensure that the appliance is switched off before replacing the lamp to avoid the possibility of electric shock.

Remove the glass cover of the lamp-holder as shown below.

Remove the lamp and replace with a lamp resistant to high temperatures (300°C) with the following characteristics:

- Voltage: 220-240V
- Wattage: 25W
- Type: G9 (Halogen lamp)
- Energy efficiency class: G

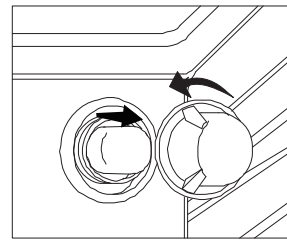

Replace the glass cover and reconnect the oven to the mains power supply.

WARNING: Please do not use screwdrivers or other utensils to remove the light cover. This could damage the enamel of the oven or the lamp holder lamp holder.

PLEASE NOTE: The bulb replacement is not covered by your guarantee. The lamp is designed specifically for use in household cooking appliances. It is not suitable for household room illumination.

Cleaning the oven door /How to remove the oven doors

For a more thorough clean, you can remove and disassemble the oven door. Proceed as follows:

Oven door structures 1 remove and assemble procedure:

- Open the door to the full extent(fig.1);
- Open the lever A completely on the left and right hinges(fig.2);
- Hold the door as shown in fig.3
- Gently close the door(fig.3)until left and right hinge levers A are hooked to part B of the door(fig.4).
- Withdraw the hinge hooks from their location following arrow C(fig.4);
- Rest the door on a soft surface;
- To replace the door, repeat the above steps in reverse order.

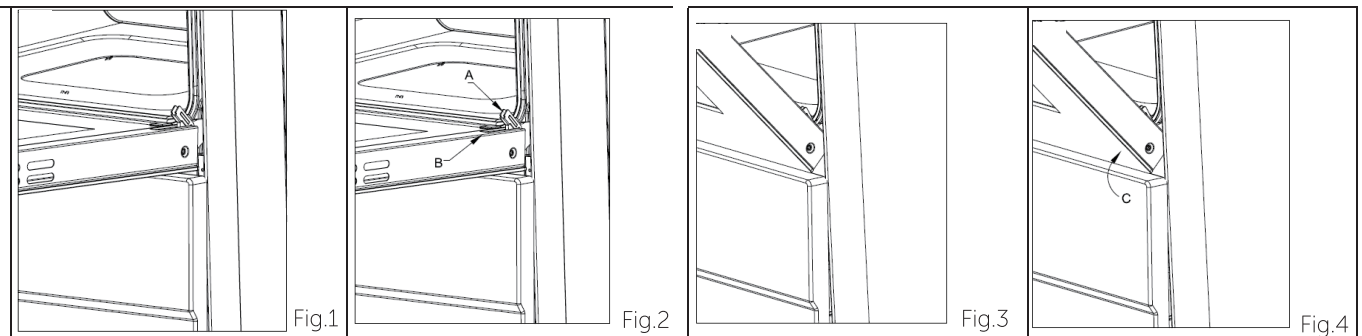

Care and maintenance

Looking after your appliance

Removing the Inner Pane of Glass

- Double oven door: Remove the seal G by unscrew the no.2 bolts (fig.5)
- Gently pull out the inner pane of glass(fig.6)
- Clean the glass with an appropriate cleaner. Dry thoroughly, and place on a soft surface.
- Now you can also clean the inside of the outer glass.

Cleaning the door glass

- Clean the glass door using non-abrasive products or sponges and dry it with a soft cloth.

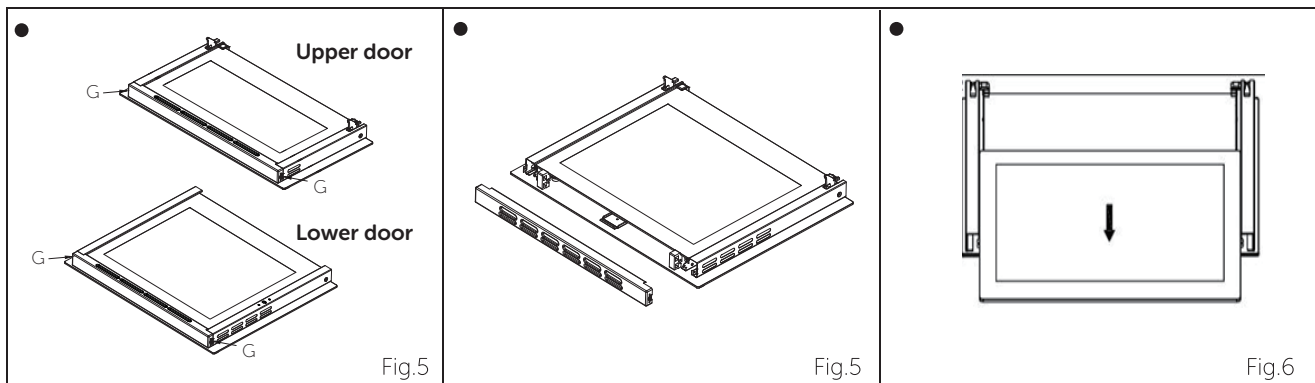

Technical specification

Model	FDC60B / FDC60W
Voltage and frequency	220-240V AC/50-60Hz
Upper oven power consumption	2340-2790W
Lower oven power consumption	1710-2030W
Total oven power consumption	4060-4830W
Upper oven usable capacity	33L
Lower oven usable capacity	73L
Power consumption for large zones	(1647-1960W)x1
Power consumption for small zones	(1098-1307W)x3
Total ceramic zone power consumption	4960-5880W
Total power consumption	9010-10700W
Energy rating	A

We apologise for any inconvenience caused by minor inconsistencies within these instructions that may occur due to product improvements and development.
All images and drawings are for illustration purposes only.

If you require any technical guidance or find that your product is not operating as intended, a simple solution can often be found in the **Troubleshooting** section of these instructions.

Product support

Help is always at hand

Energy fiche

Brand		BUSH
Model		FDC60B FDC60W
Type of Oven		ELECTRIC
Mass	kg	46 (+/-2)
Energy Efficiency Index - conventional		Upper: 92.8 Lower: N/A
Energy Efficiency Index - fan forced		Upper: N/A Lower: 89.5
Energy Class		A
Energy consumption (electricity) - conventional	kWh/cycle	Upper: 0.64 Lower: N/A
Energy consumption (electricity) - fan forced	kWh/cycle	Upper: N/A Lower: 0.77
Number of cavities		2
Heat Source		ELECTRIC
Volume	l	Upper: 33 Lower: 73
Standby mode	W	0.76
This oven complies with EN 60350-1		
Energy Saving Tips Oven	Energy Saving Tips Hob	
- Cook the meals together, if possible.	- Use cookwares having flat base.	
- Keep the pre-heating time short.	- Use cookwares with proper size .	
- Do not elongate cooking time.	- Use cookwares with lid.	
- Do not forget to turn-off the oven at the end of cooking.	- Minimize the amount of liquid or fat.	
- Do not open oven door during cooking period.	- When liquid starts boiling , reduce the setting.	
Type of Hob		Electric
Number of Cooking Zones		4
Heating Technology-1		Ceramic
Size-1	cm	Ø19
Energy Consumption-1	Wh/kg	185.6
Heating Technology-2		Ceramic
Size-2	cm	Ø15
Energy Consumption-2	Wh/kg	182.5
Heating Technology-3		Ceramic
Size-3	cm	Ø15
Energy Consumption-3	Wh/kg	182.5
Heating Technology-4		Ceramic
Size-4	cm	Ø15
Energy Consumption-4	Wh/kg	182.5
Energy Consumption of Hob	Wh/kg	183.3
This hob complies with EN 60350-2		

or online at www.argos-support.co.uk If you still require further assistance, call one of our experts on **0345 257 7271**

Product support

Help is always at hand

Circuit Diagram

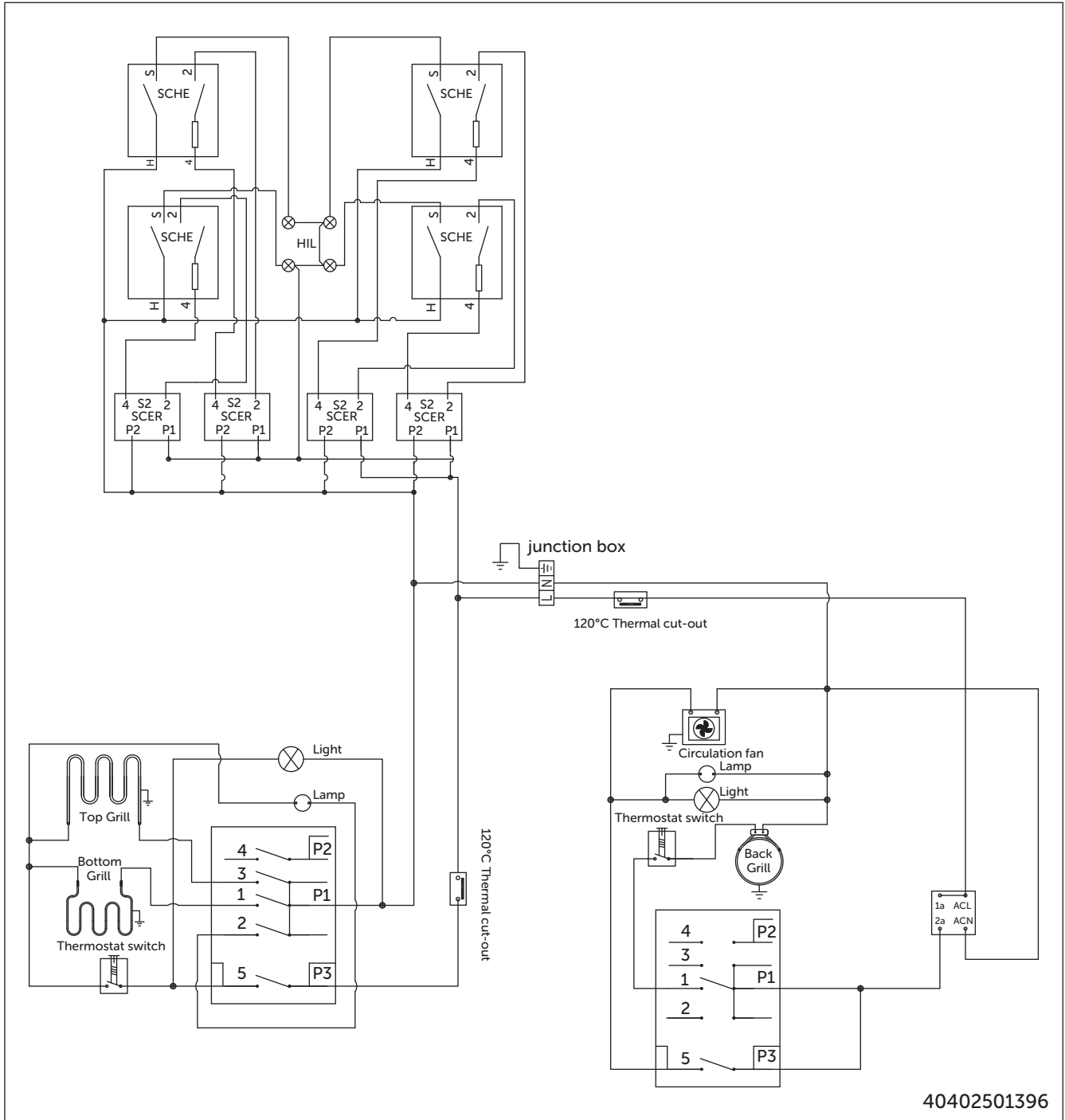

Note:

HIL: HEAT INDICATION LAMP

SCHE: SINGLE CIRCUIT HEATING ELEMENT

SCER: SINGLE CIRCUIT ENERGY REGULATOR

If you require any technical guidance or find that your product is not operating as intended, a simple solution can often be found in the **Troubleshooting** section of these instructions.

Product support

6



Product support

Help is always at hand

Troubleshooting

If you have a problem with your appliance, check the table below before calling service. You may be able to avoid a service call by and avoid unnecessary inconvenience and expense.

For cooking problems, refer to Handling Baking Problems.

Problem	Causes	What to do
Oven or grill not working	Digital Clock not set properly	Refer to digital timer instructions
	120 min Timer not in "Manual" position	Refer to 120 min timer instructions
	Power not turned on	Switch on electricity
	Household fuse blown	Check fuses
	Controls incorrectly set	Reset controls
	Circuit breaker tripped	Check circuit breaker
Oven light not working	Power not turned on	Switch on electricity
	Household fuse blown	Check fuses
	Circuit breaker tripped	Check circuit breaker
	Lamp blown or loose in socket	Replace or tighten globe
Oven not hot enough	Heat escaping through incorrectly sealed door	Check shelves or dishes are not preventing door closing properly, Check that door is fitted properly after door removal for cleaning
	Door seal is worn or has moved	Replace seal or refit it
Unit smoking when first used	Protective oils being removed	This is normal
Odour on first use of oven		This is normal
		Allow 2–4 hours for odour to dissipate (open all windows)
120 minute timer buzzer (if available) not audible	Timer not wound sufficiently	Turn timer knob past 15 minute mark Then turn to the required number of minutes
Oven shelf tight	Oven shelf not inserted correctly, may be upside down or back to front	Remove shelf and insert as per diagram

Note: Only service centers should carry out servicing. Otherwise warranty may be void.

If you require any technical guidance or find that your product is not operating as intended, a simple solution can often be found in the **Troubleshooting** section of these instructions,

Product support

Help is always at hand

Help and assistance

If you require any technical guidance or find that your Freestanding Cooker is not operating as intended, a simple solution can often be found in the **Troubleshooting** section of these instructions or online at **www.bush-support.com**

If you still require further assistance, call one of our experts on **0345 257 7271**. To help give us give you a fast and efficient service please have the following information ready:

Model Ref.	<input type="text"/>	You can find these on the rating plate - a small information panel (usually a sticker or metal plate) on the rear of your appliance
Serial number	<input type="text"/>	
Date of purchase	<input type="text"/>	This will be shown on your receipt

Local call rates applies*

Line opens 9am-6pm Monday to Saturday and 10am-6pm Sunday.

*Calls to Bush enquiry lines may attract a charge and set up fee from residential lines depending on your call plan/tariff. Mobile and other providers costs may vary, see www.bt.com/pricing for details.

For Security and training purposes, telephone calls to and from customer service centres maybe recorded and monitored. Calls from Republic of Ireland will attract international call charges.

Product support

Help is always at hand

Declaration of conformance to product standards

This appliance conforms to all relevant standards applicable to domestic appliances sold in the UK

Disposal



This appliance/fitting is marked according to the European directive 2012/19/EU on Waste Electrical and Electronic Equipment (WEEE).

By ensuring this product is disposed of correctly, you will help prevent potential negative consequences for the environment and human health, which could otherwise be caused by inappropriate waste handling of this product.

The symbol on the product, or on the documents accompanying the product, the **crossed out wheelie bin** symbol, indicates that this appliance/fitting may not be treated as household waste. Instead it shall be handed over to the applicable collection point for the recycling of electrical and electronic equipment.

Disposal must be carried out in accordance with local environmental regulations for waste disposal.

For more detailed information about treatment, recovery and recycling of this product, please contact your local authority, your household waste disposal service or the retailer where you purchased the product.



Call us now and activate your 12 month guarantee

Thank you for choosing Bush. Your new product is guaranteed against faults and breakdowns for 12 months. Don't forget to register it with us today so we can provide you with our best possible after-sales service and useful updates.

www.bushregistration.co.uk

FREEPHONE*

0800 597 8548

Lines open 09:00- 17:30 Monday to Friday

Your Bush Guarantee

This product is guaranteed for twelve months from the date of original purchase. Any defect that arises due to faulty materials or workmanship will be repaired free of charge (or if applicable the product will be replaced or the purchase price refunded) where possible during this period by the dealer from who your purchased the unit.

The guarantee is subject to the following provisions:

- The guarantee does not cover accidental damage, misuse, cabinet parts, knobs or consumable items.
- The product must be correctly installed and operated in accordance with the instructions contained in the manual.
- It must be used solely for domestic purposes. The guarantee will be rendered invalid if the product is re-sold or has been damaged by inexpert repair.
- Specifications are subject to change without notice.
- Bush disclaim any liability for loss or damage arising from the breakdown of the product.
- This guarantee is in addition to and does not diminish your statutory or legal rights.

Important Data Protection Information

To find out how we and Domestic & General Insurance Plc use your data please refer to the guarantee registration material or visit www.bushregistration.co.uk

BUSH

A decorative pattern of orange triangles of various sizes and orientations, scattered across the page. The pattern is denser at the bottom, where it forms a solid-looking field of triangles, and becomes sparser towards the top.

Produced in China for
Argos Limited, London, EC1M 6HA, UK.
Argos (N.I.) Ltd., Forestside Shopping Centre,
Upper Galwally, Belfast, BT8 6FX, UK.

Contact:
www.argos-support.co.uk
www.bush-support.com
Helpline: 0345 257 7271