

T3000 Treadmill

Assembly & User Instructions- Please Keep for future reference

793/7365

PRO FITNESS

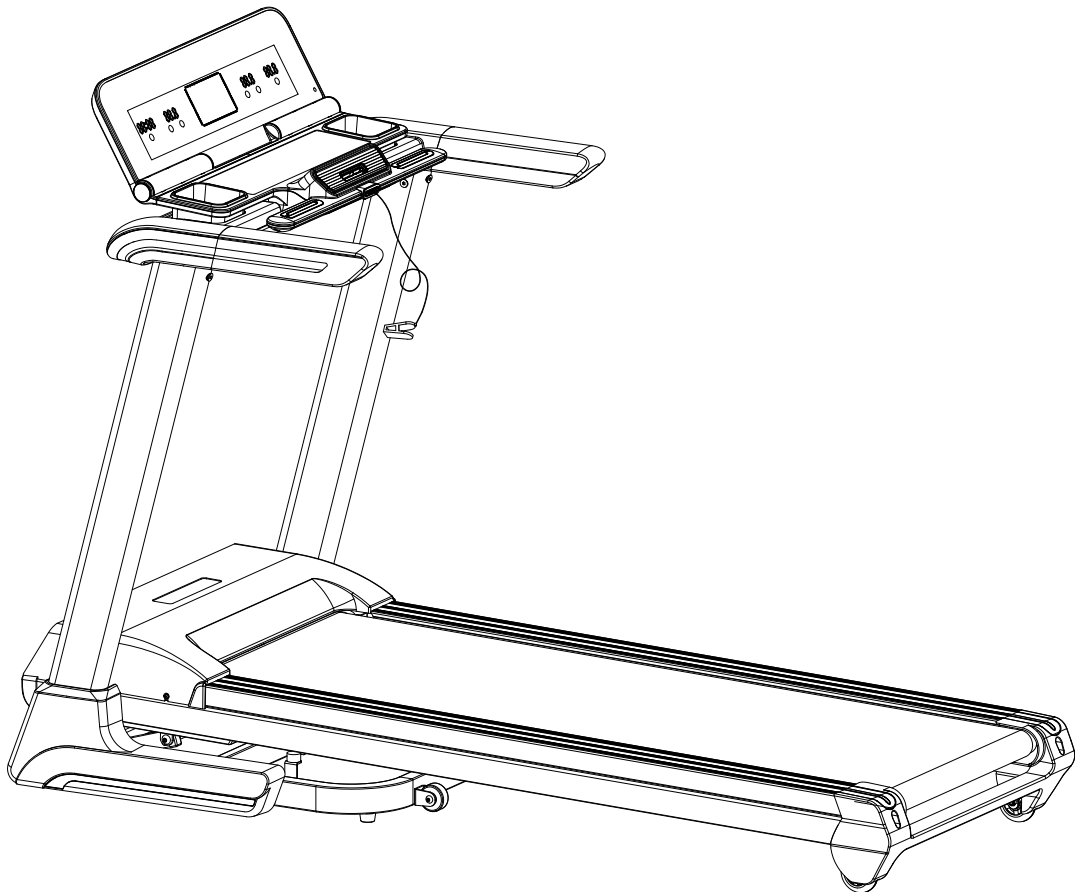

Important – Please read these instructions fully before assembly or use

These instructions contain important information which will help you get the best from your equipment and ensure safe and correct assembly, use and maintenance.

If you need help or have damaged or missing parts, call the **Customer Helpline: 0345 6001714** or visit **www.argos-support.co.uk**

Contents

Safety Information	1-2
Components-Parts	3
Components-Fixings	4
Assembly Instructions	5-9
Workout Area	10
Exercise Information	11-24
Before starting	11
Muscle Chart	12
Warming up and Cooling down	13-14
Getting started	15-16
Console operation	17-22
Folding mechanism and incline adjustment	23
Care and Maintenance	24-29
Exploded Parts Diagram	30
Parts List	31-32

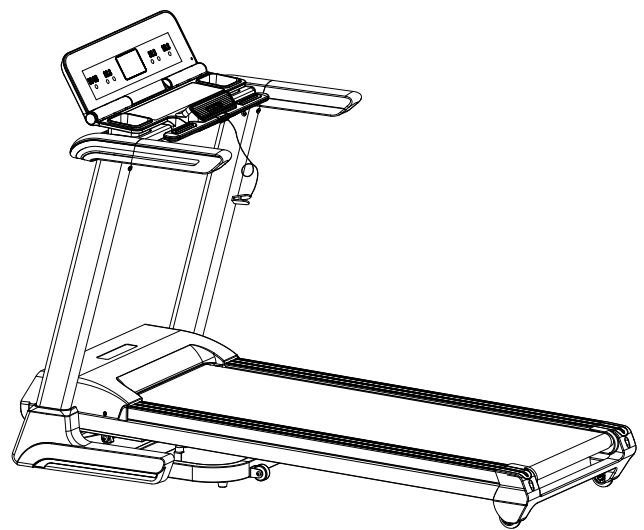



Safety information

PRO FITNESS

Important – Please read fully before assembly or use

This exercise equipment is built for optimum safety. However, certain precautions apply whenever you operate a piece of exercise equipment. Be sure to read the entire manual before you assemble, operate or use this equipment.

Assembly

- The product must be installed on a stable and level surface. Do not place the treadmill on any surface that blocks air openings. To protect the floor or carpet from damage, place a mat under the treadmill.
- Assemble the item as close to its final position (in the same room) as possible.
- Make sure you have enough space to layout the parts before starting.
- Keep children and animals away from the exercise area, small parts could pose a choking hazard if swallowed.
- Dispose of all packaging carefully and responsibly.
- Check you have all the components and tools listed in the parts list, bearing in mind that, for ease of assembly, some components are pre-assembled.
- The assembly of this equipment is best carried out by 2 people.
- Attention! Take care when unboxing and assembling your treadmill.
- On unboxing, ensure the treadmill is flat on the floor (with the wheels in contact with the ground), before cutting the retaining cable ties on both sides of the product.
- Do not under any circumstance turn the machine on its side. Failure to follow these instructions could result in serious injury.

Use

- It is the responsibility of the owner to ensure that all users of this product are properly informed as to how to use this product safely.
- This product is intended for domestic use only.
Do not use in any commercial, rental, or institutional setting.
- Use the equipment only for intended use, as described in this manual. Do not use attachments not recommended by the manufacturer.
- Keep this equipment indoors, away from moisture

and dust. Do not put the equipment in a garage, outbuilding, covered patio, or near water.

- Your product is intended for use in clean dry conditions. You should avoid storage in excessively cold or damp places as this may lead to corrosion and other related problems that are outside our control.

- Keep unsupervised children away from the equipment.

- Disabled persons should not use the equipment without a qualified person or doctor in attendance.

This product is not suitable for therapeutic purposes.

- Always wear appropriate workout clothing when exercising. **Do not** wear loose or baggy clothing, as it may get caught in the equipment. Wear trainers to protect your feet while exercising.

- **Do not** place any sharp objects around the equipment.

- Keep hands away from all moving parts.

- If any of the adjustment devices are left projecting, they could interfere with the user's movement.

- Before using the equipment to exercise, always perform stretching exercises to properly warm up.

- Only one person at a time should use the equipment.

- A spotter is recommended during exercise.

- If the user experiences dizziness, nausea, chest pain, or other abnormal symptoms **stop the workout and seek immediate medical attention.**

- Injuries to health may result from incorrect or excessive training.

- This product is suitable for a maximum user weight of: **135 kg.**

- This product conforms to: BS EN ISO 20957-1 and BS EN 957-6 Class (H) - Home Use - Class (C).

- A folded treadmill should not be operated.

- Ensure the running surface comes to a complete stop before folding.

- The A-weighted emission sound pressure level is from 50 to 60 dBa.



Safety information

- The replacement parts could affect the safe use of the treadmill.
- The max allowed lateral position of the running surface is around 5-8mm.
- Noise emission under load is higher than without load.
- When choosing a location for the equipment make sure that the location and position permit access to a plug.
- Do not operate this equipment where aerosol products are used or where oxygen is being administered.
- When connecting the power cord, plug the power cord into a grounded circuit. When replacing the fuse, an approved BS 1362 type should be fitted to the fuse carrier, A13 amp fuse should be used. No other appliance should be on the same circuit.
- Keep the power cord away from any heated surface.
- Do not operate the equipment if the power cord or plug is damaged, or if the equipment is not working properly.
- Never start the treadmill when you are standing on the running belt. Stand on the side rail, hold the handrails, start on a low speed and then step on the unit. When comfortable increase the speed to one that you are comfortable with.
- The treadmill is capable of high speeds. Adjust the speed in small increments to avoid sudden changes in speed.
- Never leave the treadmill unattended while it is running. Always remove the safety key when the treadmill is not in use.
- Always examine your treadmill before use to ensure all parts are in working order.
- Never insert any object or body parts into any opening.



Warning: Before beginning any exercise program, consult your Doctor. This is especially important for persons over the age of 35 or persons with pre-existing health problems. You **MUST** read all instructions before using any fitness equipment. Argos and its associates assumes no responsibility for personal injury or property damage sustained by or through the use of this product. Over exercising may result in serious injury or death. If you feel faint stop exercising immediately. Warning! Heart rate monitoring systems may be inaccurate. For the most accurate heart rate measure, please hold both hand pulse sensors continuously during any programme.

Components - Parts

If you have damaged or missing parts, please call the **Customer Helpline: 0345 6001714**.

Please check you have all parts listed below

Note: Some of the smaller components may be pre-fitted to larger components. Please check carefully before contacting Argos regarding any missing components.



Main Frame

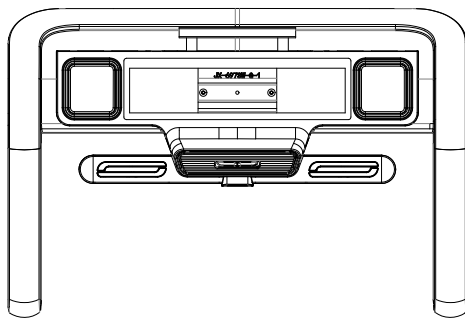

Console Upper Housing 1 x 1

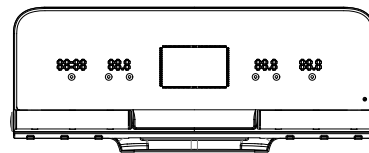

Display screen x 1

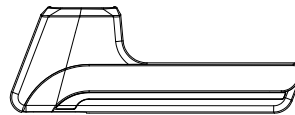

59. Left Console Mast Cover x 1

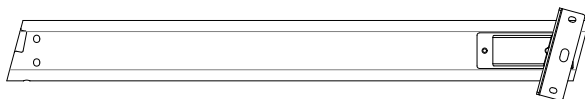

9. Left Console Mast X 1

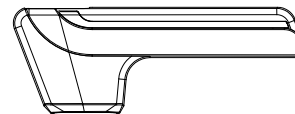

60. Right Console Mast Cover x 1

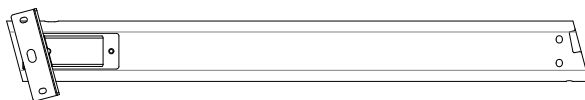

10. Right Console Mast X 1

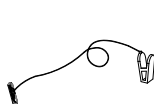

44. Safty Key x 1

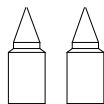

Lubrication Oil x 2



41. Power cord x 1

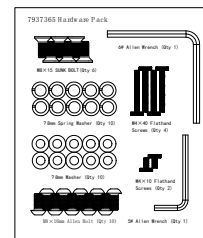







Hardware pack

Components - Fixings

PRO FITNESS

Please check you have all parts listed below

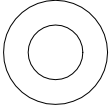
Note: The quantities below are the correct amount to complete the assembly. In some cases more hardware may be supplied than are required. Some of the fixings are pre-fitted to the larger components. Please check carefully before contacting Argos regarding any missing fixings.

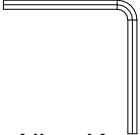
104  M8x15 SUNK BOLT × 6	105  M8x16mm Allen Bolt × 10	109  M4*40 screws × 4
107  φ 8 Spring Washer × 10	106  φ 8 Washer × 10	108  M4*8 screws × 2
5#  Allen Key × 1	6#  Allen Key × 1	

Assembly Instructions

Total mass of the product is 90 kg. Total size of the equipment is (width) 88cm × (depth) 183cm × (height) 132.5 cm.

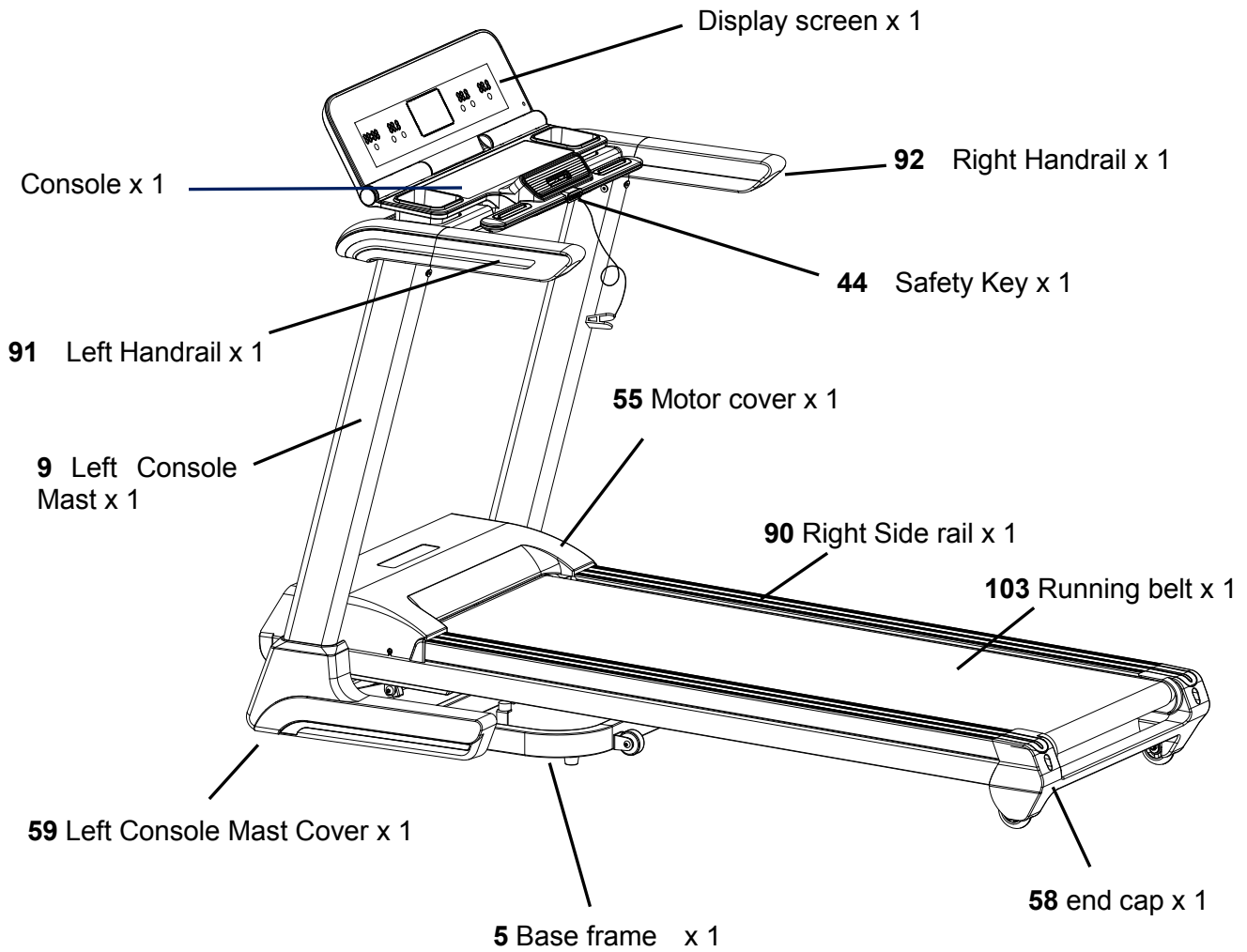

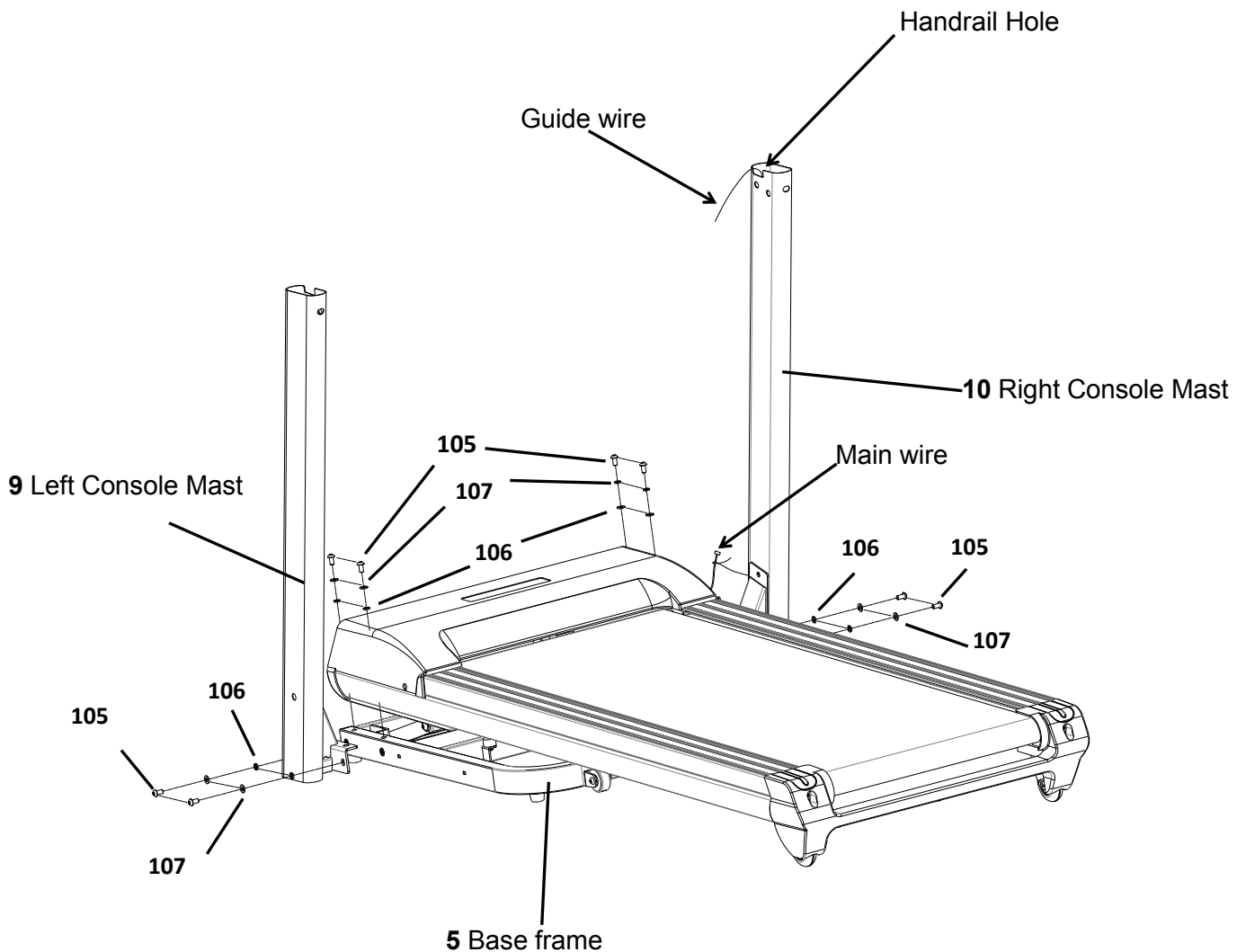

Step 1

a. Connect the guide wire from bottom of the Right Console Mast (**10**) with the main wire from the Base Frame (**5**), then pull the main wire out from the handrail hole as shown in the diagram.

Notes: Once the main wire is threaded through the Console Mast, ensure it is secured before detaching the guide wire. Failure to do this could risk the main wire falling out.

b. Fix the Console Mast (**9&10**) to the Base Frame (**5**) using 8 x M8x16mm Allen Bolt (**105**), 8 x ϕ 8 Spring Washer (**107**), 8 x ϕ 8 Washer (**106**).

Notes: Do not tighten bolts at this step.

Assembly Instructions

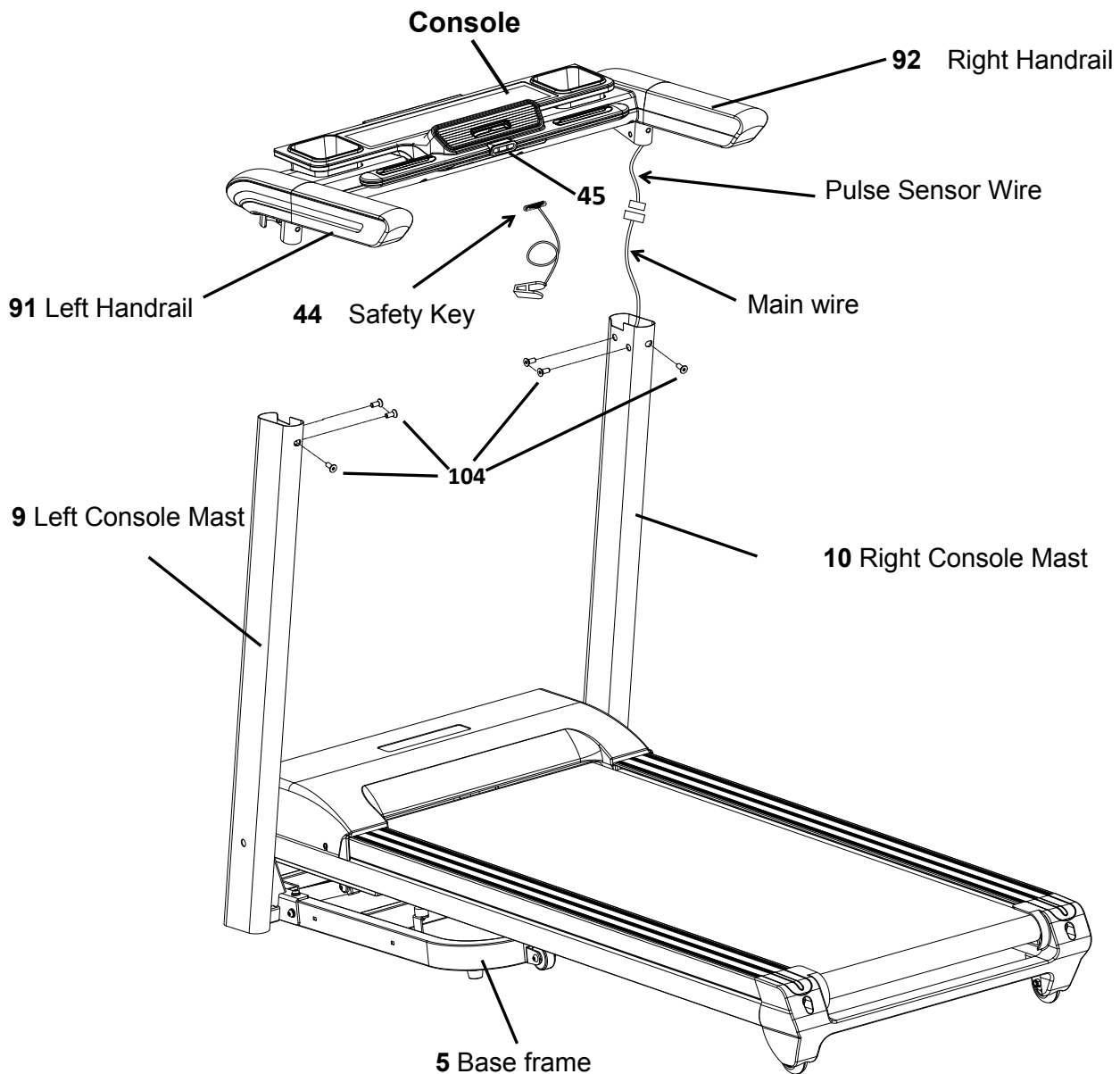

Step 2

Connect the main wire with the Pulse Sensor Wire as shown in the diagram.

Place the Console on the top of the Console Mast (**9 & 10**) and fix it using 6 x M8x15 SUNK BOLT (**104**). Then insert the safety key (**44**) into the notch of the console (**45**).

Notes: Fully tighten all the bolts in above steps.

Assembly Instructions

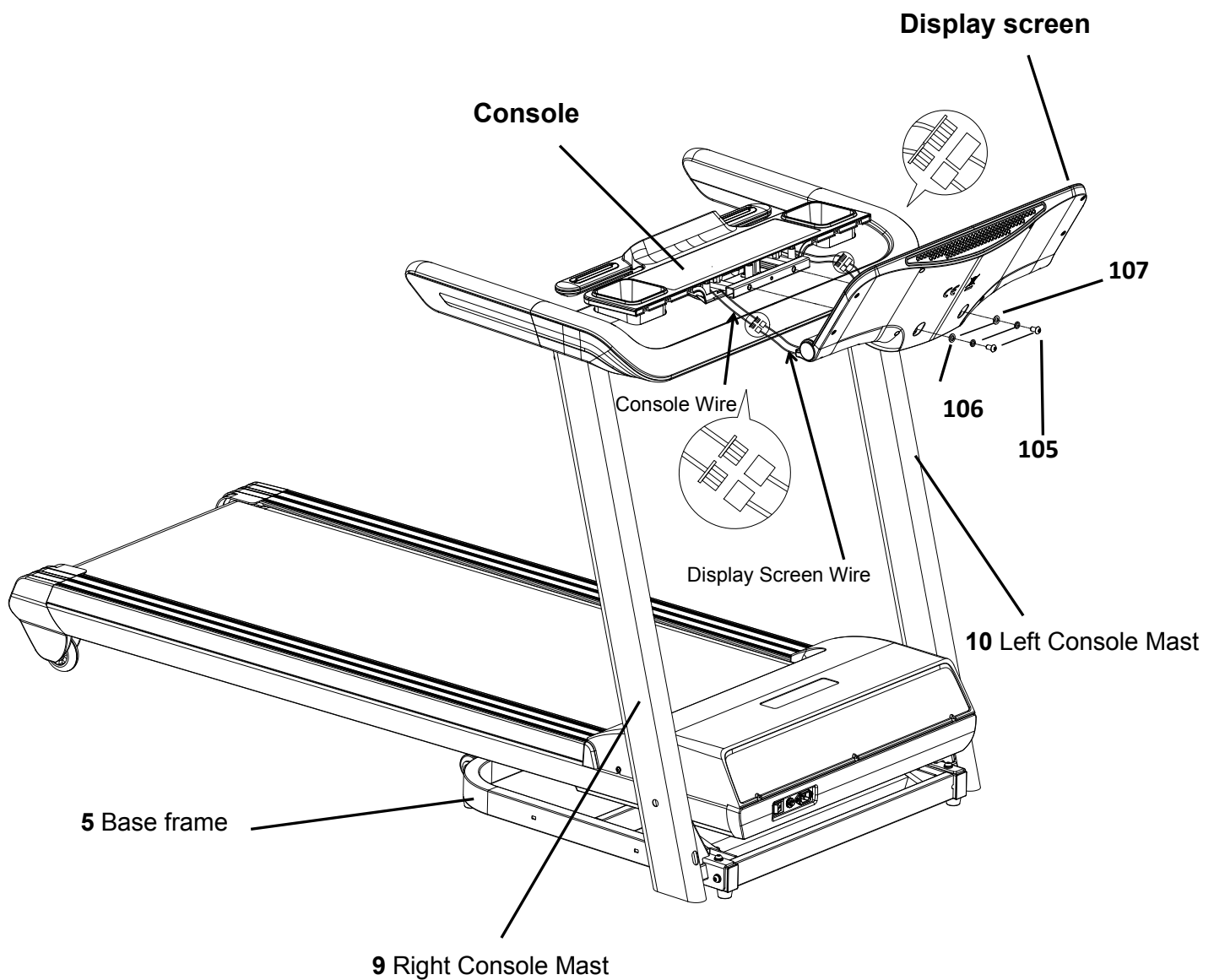

Step 3

Connect the console wire with the display screen wire as shown in the diagram.

Attach the Display screen to the Console , using 2 x M8x16mm Allen Bolt (105), 2 x φ 8 Spring Washer (107), 2 x φ 8 Washer (106).

Assembly Instructions

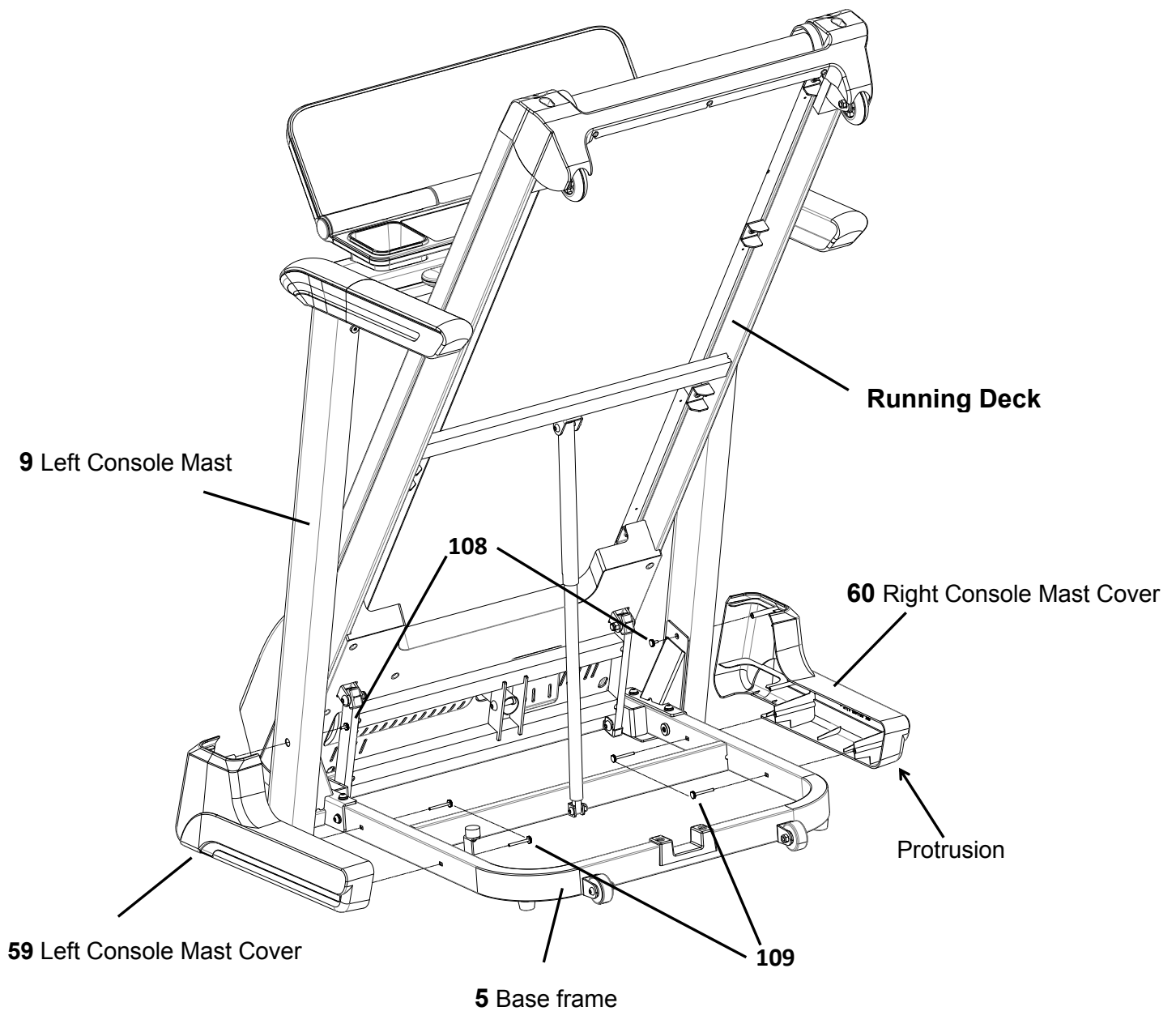

Step 4

Align and press the protrusion on the Console Mast Cover (**59 & 60**) to the holes on the Base frame (**5**) then fix with 4 x M4*40 Flat hand screws (**109**), 2 x M4*8 Flat hand screws (**108**).

Notes: when installing, the Running Deck should be lifted up as shown in the diagram.

Workout Area

The free area must be at least 0.6m greater than the training area. This is a space where you can safely dismount, without obstruction, in case of an emergency. Where two pieces of equipment are positioned adjacent to each other the free area may be shared. The free area behind the treadmill should be 2m in length and double the width of the product.

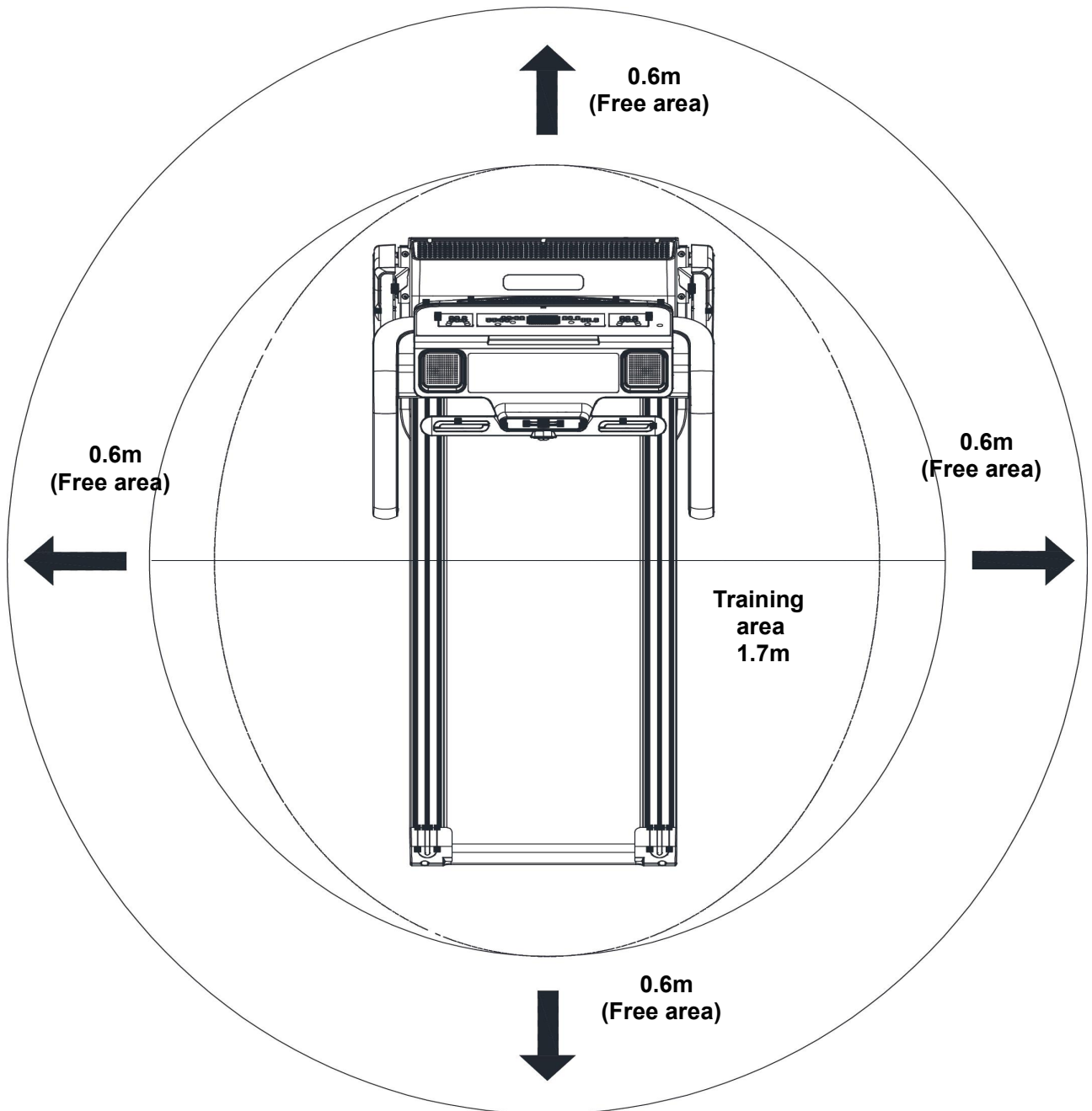

Only one person should be within the training area when the equipment is in use.

Before starting

Tailor your exercise program according to your physical condition. If you have been inactive for several years, or are overweight, you must start slowly and increase your time on the equipment; a few minutes per workout increase is advisable.

Initially, you may be able to exercise only for a few minutes in your target zone, however, your aerobic fitness will improve over the next six to eight weeks. Don't be discouraged if it takes longer. It's important to work at your own pace.

Please remember these essentials:

- Have your doctor review your training and diet programs to advise you of a workout routine you should adopt.
- Begin your training program slowly with realistic goals.
- Monitor your pulse frequently. Establish your target heart rate based on your age and condition.
- Set up your equipment on a flat even surface with adequate training area, as prescribed in this manual.

Exercise intensity

To maximize the benefits of exercising, it is important to exercise at an appropriate intensity. The intensity level can be found by using your heart rate as a guide. For effective aerobic exercise, your heart rate should be maintained at a level between 65% and 85% of your maximum heart rate as you exercise. This is known as your target zone. You can find your target zone in the table below.

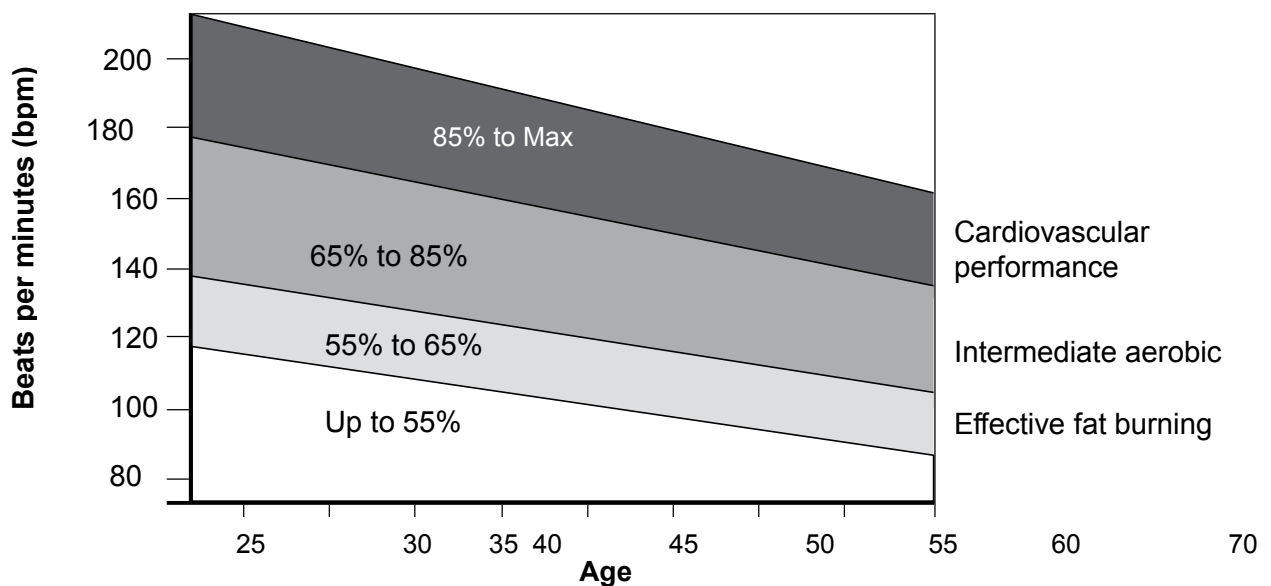

During the first few months of your exercise program, keep your heart rate near the low end of your target zone as you exercise. After a few months, your heart rate can be increased gradually until it is near the middle of your target zone as you exercise.

To measure your heart rate, stop exercising but continue moving your legs or walking around and place two fingers on your wrist. Take a six-second heartbeat count and multiply the results by 10 to find your heart rate. For example, if your six-second heartbeat count is 14, your heart rate is 140 beats per minute.

(A six-second count is used because your heart rate will drop rapidly when you stop exercising.) Adjust the intensity of your exercise until your heart rate is at the required level.

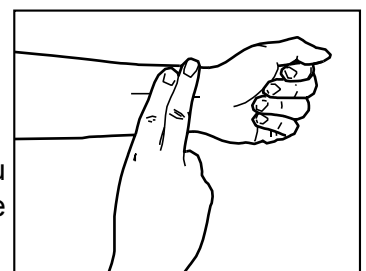

Exercise Information

Muscle Chart

Aerobic Exercise

Aerobic exercise improves the fitness of your lungs and heart - your body's most important muscle. Aerobic exercise is promoted by any activity that uses your large muscles (arms, legs, or buttock, for example).

Weight Training

Along with aerobic exercising which helps get rid of and keep off the excess fat that our bodies can store, weight training is an essential part of an exercise routine. Weight training helps tone, build and strengthen muscle. If you are working above your target zone, you may want to do a lower number of reps.

Targeted Muscle Groups

The exercise routine that is performed on the treadmill will develop the lower body muscle groups. These muscle groups are highlighted on the muscle chart below.

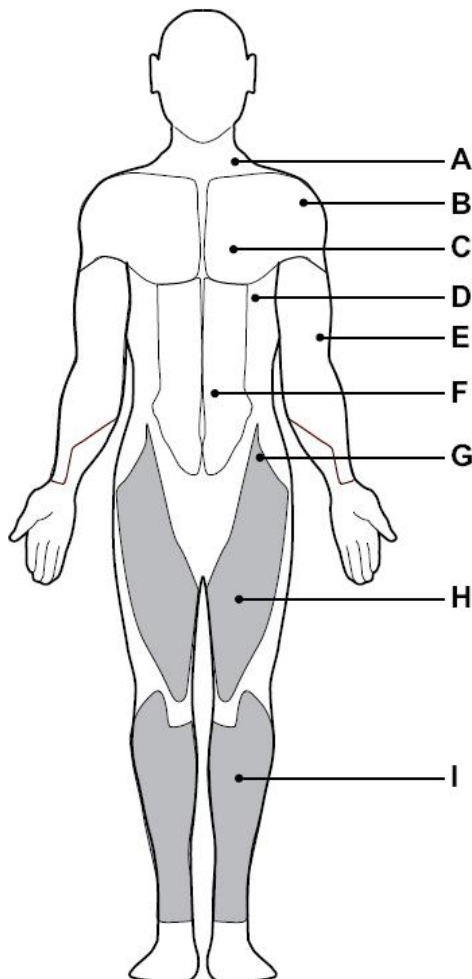

Front

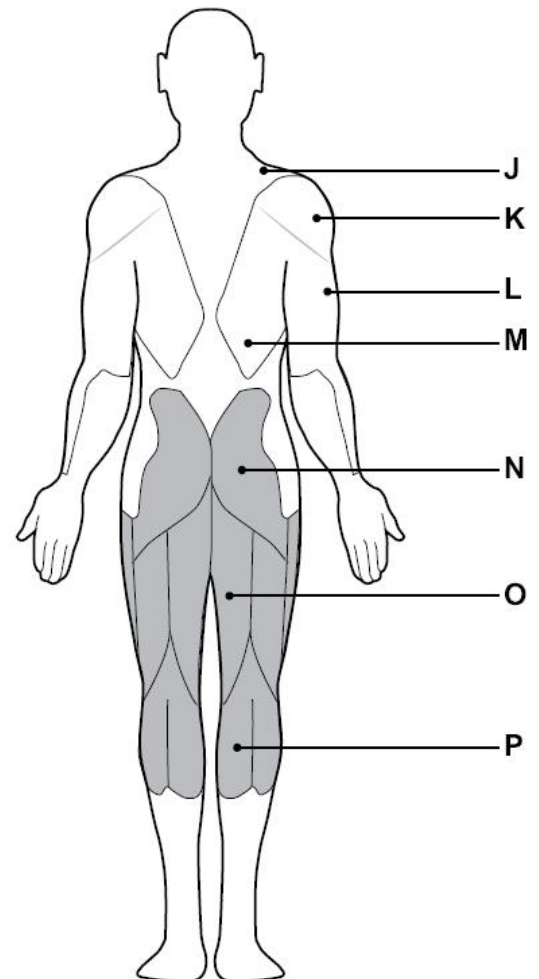

Back

A: Trapezius
B: Anterior Deltoid
C: Pectoralis Major
D: Serratus Anterior

E: Biceps
F: Abdominal
G: Sartorius
H: Quadriceps

I: Tibialis Anterior
J: Trapezius
K: Posterior Deltoid
L: Triceps

M: Latissimus Dorsi
N: Gluteals
O: Hamstrings
P: Gastrocnemius

Warming up and Cooling down

Each workout should include the following three parts:

1. A warm-up, consisting of 5 to 10 minutes of stretching and light exercise. A proper warm-up increases your body temperature, heart rate, and circulation in preparation for exercise.
2. Training zone exercise, consisting of 20 to 30 minutes of exercising with your heart rate in your training zone. (**Note:** During the first few weeks of your exercise program, do not keep your heart rate in your training zone for longer than 20 minutes.)
3. A cool-down, with 5 to 10 minutes of stretching. This will increase the flexibility of your muscles and will help to reduce post-exercise muscle soreness.

Exercise Frequency

To maintain or improve your fitness, plan three workouts each week, with at least one day of rest between workouts. After a few months of regular exercise, you may complete up to five workouts each week, if desired. Remember, the key to success is make exercise a regular and enjoyable part of your everyday life.

Toe touch stretch

Stand with your knees bent slightly and slowly bend forward from your hips. Allow your back and shoulders to relax as you reach down towards your toes as far as possible.

Hold for 15 counts, then relax

Repeat 3 times.

Stretches: Hamstrings, back of knees and back.

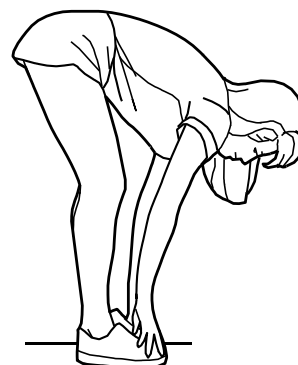

Hamstring stretch

Sit with one leg extended. Bring the sole of the opposite foot toward you and rest it against the inner thigh of your extended leg. Reach towards your toes as far as possible.

Hold for 15 counts, and then relax.

Repeat 3 times for each leg.

Stretches: Hamstrings, lower back and groin.

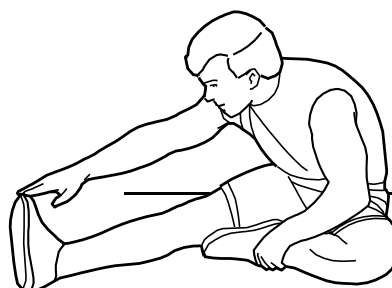

Exercise Information

Calf/Achilles stretch

With one leg in front of the other, reach forward and place your hands against a wall. Keep your back leg straight and your back foot flat on the floor. Bend your front leg, lean forward and move your hips toward the wall.

Hold for 15 counts, then relax.

Repeat 3 times for each leg. To cause further stretching of the Achilles tendons, bend your back leg as well.

Stretches: Calves, Achilles tendons and ankles.

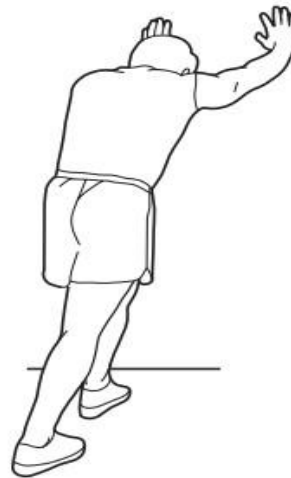

Quadriceps stretch

With one hand against the wall for balance, reach back and grasp one foot with your other hand. Keeping your bent knee pointing directly down towards the floor, gently pull your heel towards your buttock until you feel a gentle stretch in the target area.

Hold for 15 counts, and then relax.

Repeat 3 times for each leg.

Stretches: Quadriceps and Hip muscles.



Inner thigh stretch

Sit with the soles of your feet together and your knees outwards. Pull your feet towards your groin area as far as possible, and push your knee down towards the ground.

Hold for 15 counts, and then relax.

Repeat 3 times.

Stretches: Quadriceps and Hip muscles.



Exercise Information

Getting Started

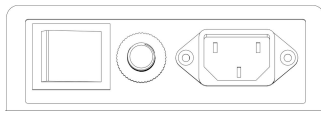

85 86

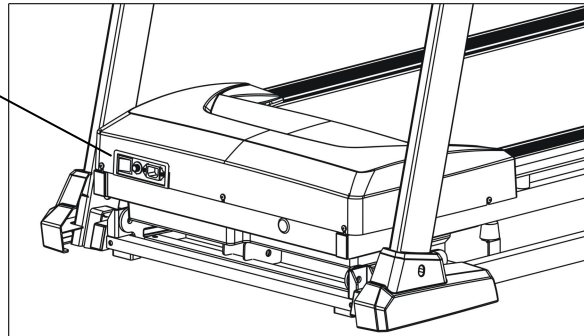

Plug your fitness equipment into the mains power and turn on the switch (85). You will hear a beep and the computer screen will light up.

OVER-CURRENT PROTECTOR:

There is an over-current protector (86) located on the right side of the switch (85) (see above picture); in case of short circuit or over-current, the Button of the over current protector will pop up and the treadmill will power off; please unplug the power source and push down the button. Plug the machine back in and then turn on the switch to restart your treadmill. If the button pops up again, please contact the Customer Helpline 0345 600 1714.

Exercise Information

Getting Started

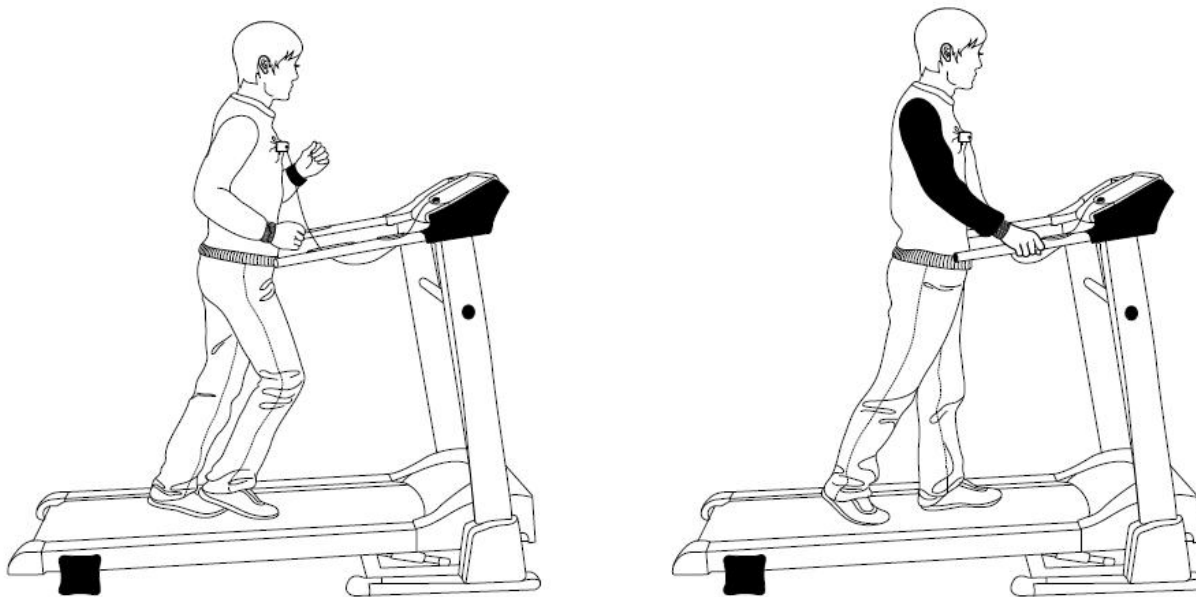
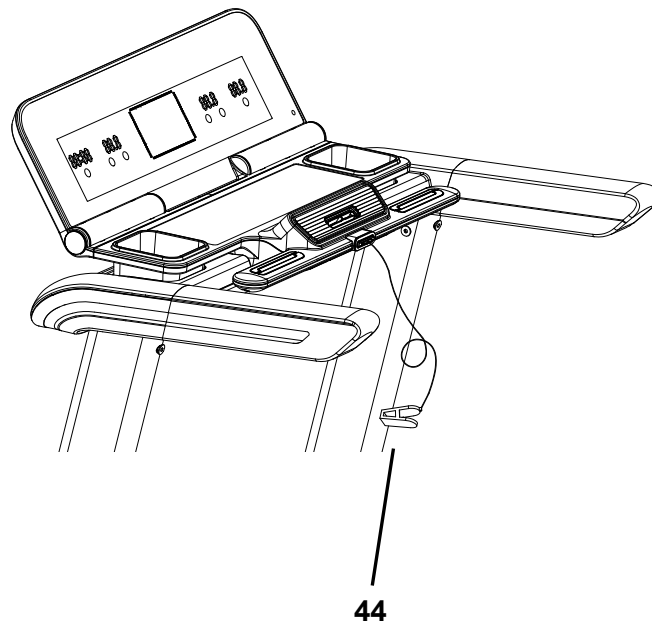

SAFETY KEY:

The treadmill will only work if the safety key (44) is properly locked in the provided notch of the console. Insert the safety key (44) and attach the clip to your chest or the waist belt of your clothes. Then move backward to test the safety key. The safety key should be able to be pulled out from the console with the clip still on your clothes.

If you need to turn the motor off immediately, just pull the safety key (44) out of the console. For emergency dismount hold the left or right handlebar then jump onto the side rail or the floor.

Exercise Information

Console Operation

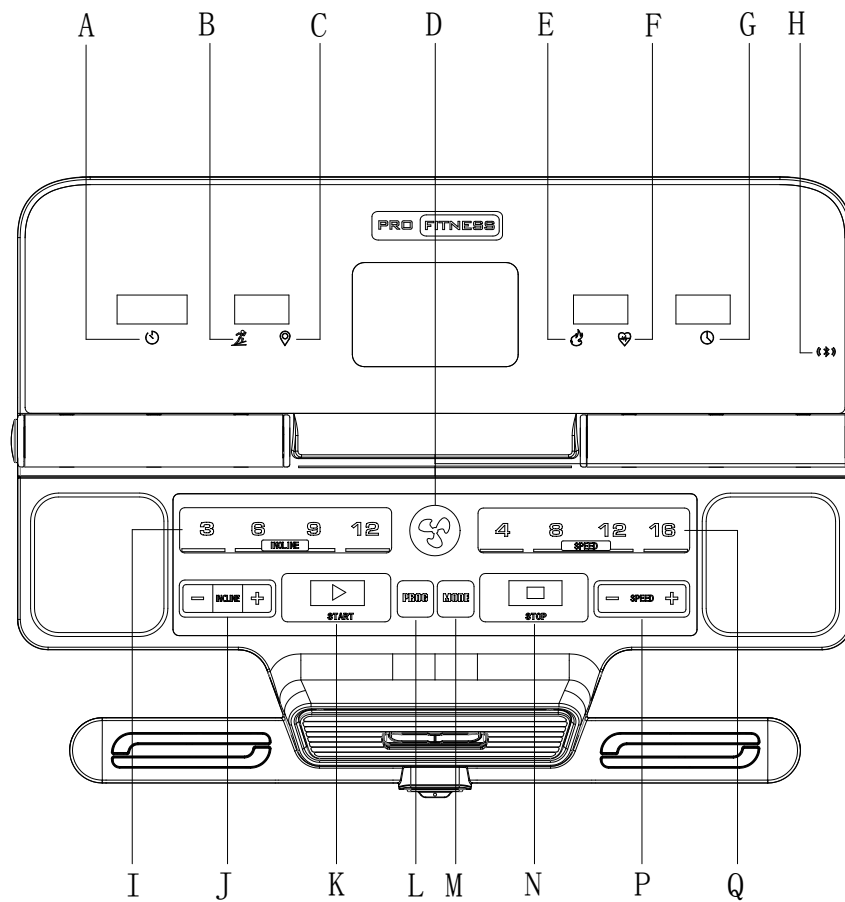

- A: Time**
- B: Incline**
- C: Distance**
- D: Fan**
- E: Calorie**
- F: Heart**
- G: Speed**
- H: Bluetooth**
- I: Quick Incline select(3%,6%,9%,12%)**
- J: Incline- / Incline+**
- K: Start**
- L: Program**
- M: Mode**
- N: Stop**
- P: Speed- / Speed+**
- Q: Quick speed select(4km/h,8km/h,12km/h,16km/h)**

Exercise Information

Console Operation

TECHNICAL SPECIFICATION

Time-----	00:00--99:59 min/sec
Speed-----	0.0--20.0 km/h
Distance-----	0.0--99.9 km
Calorie-----	0.0--999 Kcal
Incline -----	0-18%
Pulse-----	50-190 BPM

START

Press to start exercise at initial speed 0.8km/h.

STOP

Press the key during workout. The treadmill will stop by gradually reducing the speed and incline.

QUICK SPEED SELECT

Press to select your desired running speed with 4km/h, 8km/h, 12 km/h, 16km/h

SPEED UP/DOWN

1. Press to increase/decrease exercise speed by 0.1km/h.
2. Press to select training time within a workout programme.
3. Press to choose the desired training target (Time, Distance, and Calories) within the target workouts.

INCLINE UP/DOWN

1. Press to increase/decrease running deck incline by 1%.
2. Press to select training time within a workout programme.
3. Press to choose the desired training target (Time, Distance, and Calories) within the target workouts.

MODE

Press to select training target workout mode (Time-Distance-Calorie count down)

FAN

Press to turn on the fan and press again to turn it off.

QUICK INCLINE SELECT

Press to select your desired running deck incline of 3%, 6%, 9% or 12%.

Bluetooth

Turn your mobile phone Bluetooth on, connect with your treadmill(JXBLE-7937365), then you can: Play your mobile phone music, adjust the volume by your mobile phone;

PROGRAM

Press to select workout program (P01-P02-...-P36).

IMPORTANT

The console will turn off automatically about ten minutes after the belt has stopped.

SAFETY KEY

1. The safety key must be placed into the magnetic recess on the console in order to operate the treadmill. Always place the safety key on its position and attach the clip to your clothing at your waist before beginning your workout.
2. If you need to stop the motor immediately, simply pull the safety key away from the console.

GENERAL OPERATION

1. Turn on the Power Switch at the front of your Treadmill. This switch is located next to the Mains Power Cord inlet.
2. Place the Safety Key into the magnetic recess on the middle front of the Computer Console.

The console will give an audible signal and all console window displays function with a start display value of 0.

Note: If the Safety Key is not placed correctly or is faulty, the "Speed" window will display "E00", which indicates that the treadmill will not operate.

To stop the treadmill in an emergency, simply pull the safety key off its mount in the console front or simply press the red STOP button in the right of the console. It is important that you connect the clothing clip to your shirt or other suitable clothing during exercise to ensure that this safety system can operate easily.

Exercise Information

Console Operation

TRAINING TIME CONTROL WORKOUT MODE

1. Turn on the treadmill, press the “Mode” once, and the “Time” window flashes and displays “15:00”, which is the pre-set training time of the treadmill. Press “Speed +” / “Speed -” or “Incline+”/“Incline-” to select your desired training time, (the range is 5:00—99:00).
2. Press “Start” to start your workout, the time data will reduce gradually during your training and the treadmill will stop automatically when the “Time” window displays “0:00”.

TRAINING DISTANCE CONTROL WORKOUT MODE

1. Turn on the treadmill, press the “Mode” key twice, and the “Dis” (Distance) window flashes and displays “1.0”, which is the pre-set training distance of the treadmill.
2. Press “Speed +” / “Speed -” or “Incline +”/“Incline-” to select your desired training distance (the range is 0.50—99.9).
3. Press “Start” to start your workout, the distance

data will reduce gradually during your training and the treadmill will stop automatically when the “Dis” (Distance) window displays “0.0”.

BURNING CALORIE CONTROL WORKOUT MODE

1. Turn on the treadmill, press the “Mode” three times continuously, the “Cal” (Calorie) window flashes and displays “50.0”, which is the pre-set burning calories of the treadmill. Press “Speed +” / “Speed -” to select target burning calories (the range is 10.0---999).
2. Press “Start” to start your workout, the calories data reduce gradually during your training, and the treadmill will stop automatically when the “Cal” (Calorie) window display “0.0”.

SPEED ADJUSTMENT

In any training target control workout MODE, press “Speed +” / “Speed -” to choose your desired running speed.

Exercise Information

Console Operation

Program Workout Mode (P01—P36)

In this mode, the user has a choice of Program P01 – Program P36.

1. Press the “Prog. ”, the “Speed” window will display “P01” and the “Time” window will display “15:00”, which is the preset time of the treadmill for each program. Press the “Pro.” to select your desired training program “P01-P36”.
2. The preset workout time of the treadmill for each program is 15:00 Min, when you finish selecting workout program, press “Speed +” / “Speed -” to select your desired workout time

(the range is: 5:00---99:00).

3. Press “Start” and the treadmill will count down three and start operation. The start speed depends on the program you have chosen.
4. For all preset values, please refer to following table and diagrams.

Any of the training program levels has 10 segments, and each segment time is 1/10 of total setting time; during any training segments, press the “Speed +” / “Speed -” to adjust training speed.

PROG	TIME	Set Time/15 =Running time for each program									
		1	2	3	4	5	6	7	8	9	10
P1	SPEED	1.5	3.0	4.5	6.0	7.5	9.0	10.5	10.5	9.0	7.5
	INCLINE	1	1	2	2	2	3	3	2	2	2
P2	SPEED	3.0	4.5	7.5	3.0	4.5	7.5	3.0	4.5	7.5	3.0
	INCLINE	1	2	2	2	2	4	4	3	2	2
P3	SPEED	4.5	6.0	7.5	6.0	4.5	6.0	7.5	6.0	4.5	6.0
	INCLINE	2	3	3	2	2	6	6	3	2	2
P4	SPEED	3.0	3.0	4.5	4.5	6.0	6.0	7.5	7.5	9.0	9.0
	INCLINE	2	3	3	2	2	6	6	3	2	2
P5	SPEED	3.0	4.5	6.0	7.5	9.0	9.0	7.5	6.0	4.5	3.0
	INCLINE	3	3	3	4	4	3	3	2	2	2
P6	SPEED	7.5	7.5	6.0	4.5	3.0	1.5	3.0	4.5	6.0	7.5
	INCLINE	3	5	5	5	4	3	3	4	3	2
P7	SPEED	3.0	6.0	4.5	9.0	4.5	7.5	3.0	9.0	6.0	4.5
	INCLINE	4	4	4	4	3	6	6	5	3	3
P8	SPEED	1.5	3.0	4.5	6.0	6.0	6.0	6.0	4.5	3.0	3.0
	INCLINE	4	5	5	5	6	12	12	8	6	3
P9	SPEED	3.0	3.0	4.5	7.5	7.5	7.5	7.5	4.5	3.0	3.0
	INCLINE	5	5	5	6	6	9	9	7	4	2
P10	SPEED	1.5	3.0	4.5	7.5	6.0	4.5	3.0	6.0	3.0	1.5
	INCLINE	4	6	4	2	5	7	8	3	2	1
P11	SPEED	3.0	4.5	3.0	6.0	4.5	6.0	6.0	4.5	3.0	3.0
	INCLINE	4	5	3	2	6	6	2	2	2	2
P12	SPEED	1.5	3.0	3.0	4.5	4.5	6.0	4.5	3.0	1.5	1.5
	INCLINE	1	2	3	2	3	5	5	0	0	2
P13	SPEED	3	6	7	5	9	9	7	5	5	7
	INCLINE	3	3	5	6	5	3	3	7	5	3
P14	SPEED	2	2	4	5	6	5	4	3	2	1
	INCLINE	4	4	4	4	3	3	6	6	6	7
P15	SPEED	2	4	6	8	6	6	4	4	2	2
	INCLINE	3	3	3	4	4	5	5	5	4	4
P16	SPEED	2	4	6	8	10	8	6	4	2	2
	INCLINE	5	5	5	6	6	6	4	4	6	6

Exercise Information

Console Operation

PROG	TIME	Set Time/10 =Running time for each program									
		1	2	3	4	5	6	7	8	9	10
P17	SPEED	2	2	6	6	8	10	6	6	2	2
	INCLINE	4	5	5	5	6	6	6	7	8	9
P18	SPEED	2	3	4	5	2	3	4	5	3	2
	INCLINE	4	4	4	4	3	3	6	6	6	7
P19	SPEED	2	4	6	2	4	6	2	4	6	2
	INCLINE	3	5	5	5	4	4	4	3	3	3
P20	SPEED	1	3	4	5	6	5	4	3	2	1
	INCLINE	3	3	3	4	4	5	5	5	4	4
P21	SPEED	4	5	4	4	4	2	3	3	5	3
	INCLINE	1	2	2	1	1	3	3	2	2	2
P22	SPEED	5	6	4	4	4	2	2	5	4	4
	INCLINE	2	2	3	3	3	4	4	3	2	2
P23	SPEED	2	4	4	4	4	2	4	5	3	4
	INCLINE	2	2	4	4	4	6	6	3	2	3
P24	SPEED	3	5	9	5	5	6	6	4	4	5
	INCLINE	2	2	4	4	4	6	6	3	2	3
P25	SPEED	3	4	5	4	3	3	6	5	4	4
	INCLINE	4	4	5	5	3	3	3	2	2	3
P26	SPEED	1	3	6	4	4	2	5	4	3	4
	INCLINE	3	4	4	4	3	3	3	4	3	5
P27	SPEED	4	5	3	3	3	6	6	5	3	3
	INCLINE	2	4	8	9	9	6	6	5	4	4
P28	SPEED	1	3	4	4	4	2	3	4	4	3
	INCLINE	3	2	2	4	3	2	2	4	6	5
P29	SPEED	2	5	5	5	4	5	6	3	3	4
	INCLINE	5	5	8	8	9	9	9	7	4	5
P30	SPEED	6	6	5	4	4	2	4	4	3	5
	INCLINE	4	5	5	8	8	10	10	8	6	6
P31	SPEED	4	2	4	4	3	4	5	5	4	8
	INCLINE	2	4	5	6	3	2	5	5	2	3
P32	SPEED	5	5	2	2	4	5	5	7	6	9
	INCLINE	3	5	7	3	3	5	6	5	3	3
P33	SPEED	2	3	2	1	3	2	9	9	4	7
	INCLINE	2	0	0	5	5	3	2	3	2	5
P34	SPEED	2	3	4	5	6	5	4	3	2	4
	INCLINE	4	2	2	4	2	6	6	5	4	4
P35	SPEED	2	4	6	8	6	6	4	4	2	6
	INCLINE	4	4	5	5	3	3	3	2	2	3
P36	SPEED	2	4	6	8	6	6	4	4	2	6
	INCLINE	5	5	8	8	9	9	9	7	4	5

Exercise Information

Console Operation

BODY FAT ANALYSIS

- On standby, press “Prog” until big window displays “FAT”, and “Distance” window displays: F1—Sex, F2—Age , F3—Height, F4—Weight, F5—Body Fat test; press “Mode” to enter next setting, press “Speed+/-” to set parameters (see below table) for F1—F4.
- When "Distance" window displays F5, Grasp the two handle pulse sensor with your two hands and hold firmly for about 5 seconds, it will display your body fat score, reflected in the big window.
Note: The data is only for reference, not for therapeutic purpose.

Body Fat Scale Parameter Table

FAT	ITEM	SET OR ANALYSIS DATA	
F-1	Sex	1-Male	2-Female
F-2	Age	10-99 (25)	
F-3	Height	100-220 (170)	
F-4	Weight	20-150 (20)	
F-5	Body Fat	≦ 19	Under weight
		20~24	Ideal weight
		25~29	Over weight
		≧ 30	obesity

Exercise Information

Folding Mechanism and Locking System

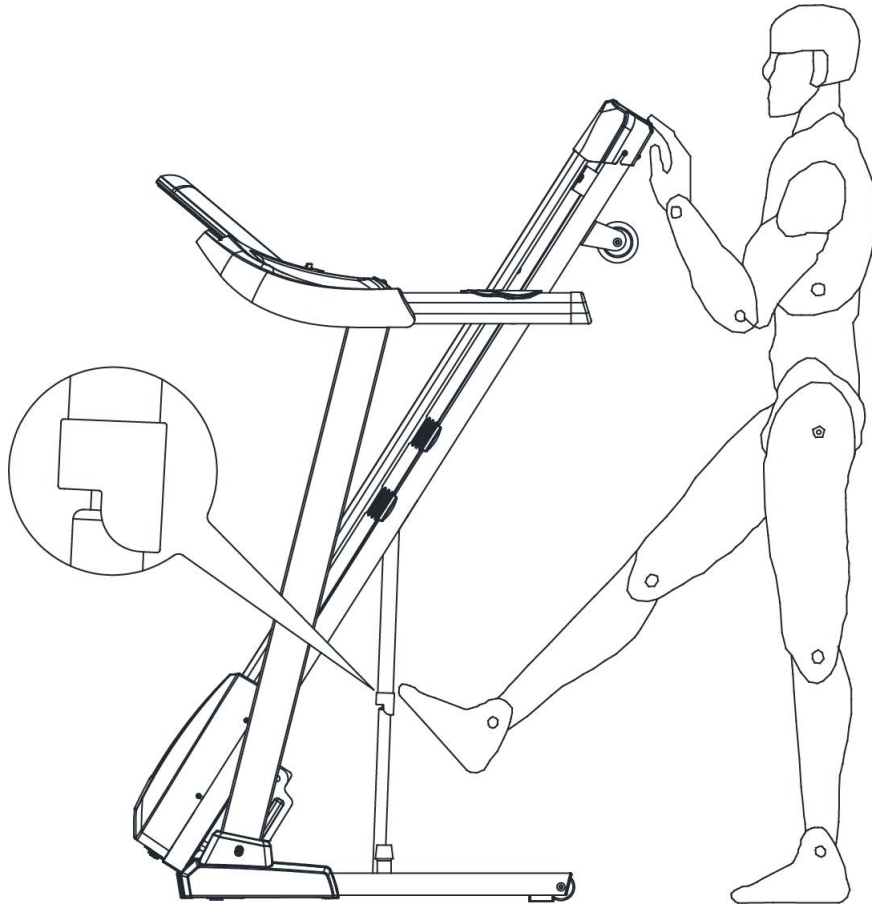

1. To fold the treadmill, lift the running deck and you can hear a click when the deck locks into position.
2. Hold the running deck, touch the cylinder joint with your tiptoes to unfold it as shown in the diagram.

Warning!

- A folded treadmill should not be operated.
- Allow the running surface to come to a complete stop before folding.

Care and Maintenance

1. The safety level of the equipment can only be maintained if it is examined regularly for damage and wear e.g. ropes, pulleys and connection points.

2. Lubricate moving parts with light oil periodically to prevent premature wear. Never use abrasives or solvents to clean the treadmill. To prevent damage to the computer, keep liquids away and keep it out of direct sunlight.

3. Inspect and tighten all parts before using the equipment. Replace defective components immediately and/or keep the equipment out of use until repair.

Pay special attention to components most susceptible to wear.

4. The equipment can be cleaned using a damp cloth and mild non-abrasive detergent. **Do not** use solvents.

5. Do not attempt to repair this equipment yourself. Should you have any difficulty with assembly, operation or use of your exercise product or if you think that you may have parts missing, contact the manufacturer, their approved service agent or the

Customer Helpline:

0345 600 1714

www.argos-support.co.uk/

Guarantee:

For guarantee purposes, please retain your purchase receipt.

Information for Users on Disposal of old Equipment

These symbols indicate that equipment with these symbols should not be disposed of as general household waste. If you want to dispose of the product or battery, please consider the collection systems or facilities for appropriate recycling.



Always unplug the equipment before cleaning and/or servicing. Service to this equipment should only be performed by an authorized service representative, unless authorized and/or instructed by the manufacturer.

Care and Maintenance

Belt Adjustment

Improper maintenance can cause damage to the treadmill or shorten the life of the product and exceed the LIMITED WARRANTY coverage.

- **Important:** Never use abrasives or solvents to clean the treadmill. To prevent damage to the computer, keep liquids away and keep it out of direct sunlight.
- All parts of the treadmill must be checked and tightened regularly. Worn parts must be replaced immediately.

BELT ADJUSTMENT

You may need to adjust the running belt during the first few weeks of use. All running belts are properly set at the factory. It may stretch or become misaligned following use. Stretching is normal during the break-in period.

ADJUSTING THE BELT TENSION

If the running belt feels as though it is “slipping” or hesitating when you plant your foot during a run, the tension on the running belt may have to be increased.

TO INCREASE THE RUNNING BELT TENSION

STEP 1: Place 6# Allen wrench on the left belt tension bolt. Turn the wrench clockwise 1/4 turn to draw the rear roller and increase the belt tension.

STEP 2: Repeat STEP 1 for the right belt tension bolt. You must be sure to turn both bolts the same number of turns, so the rear roller will stay square relative to the frame.

- Repeat STEP 1 and STEP 2 until the slipping is eliminated.
- Be careful not to tighten the running belt tension too much as you can create excessive pressure on the front and rear roller bearings. An excessively tightened running belt may damage the roller bearings that would result in bearing noise from the front and rear rollers.

TO DECREASE THE TENSION ON THE RUNNING BELT, TURN BOTH BOLTS COUNTER-CLOCKWISE THE SAME NUMBER OF TURNS.

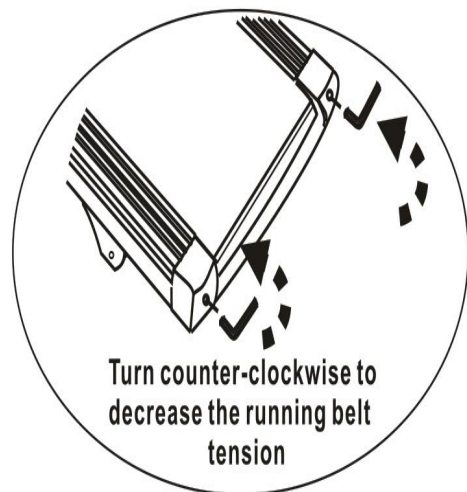
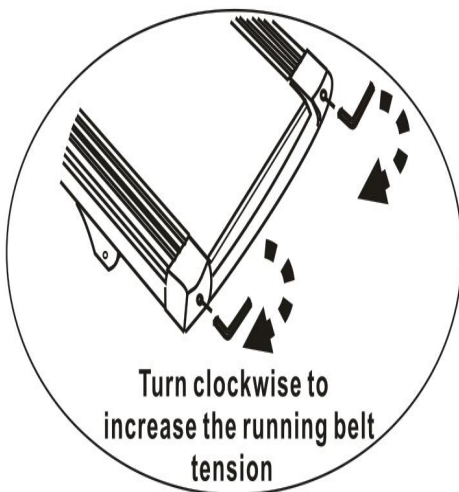

Care and Maintenance

Belt Adjustment

CENTRING THE RUNNING BELT

When you run, you may push off harder with one foot than with the other. The severity of the deflection depends on the amount of force that one foot exerts in relation to the other. This deflection can cause the belt to move off-centre. This deflection is normal and the running belt will centre when nobody is on the running belt. If the running belt remains consistently off-centre, you will need to centre the running belt manually.

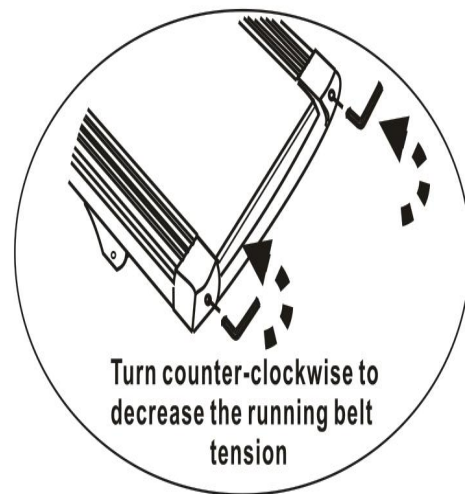
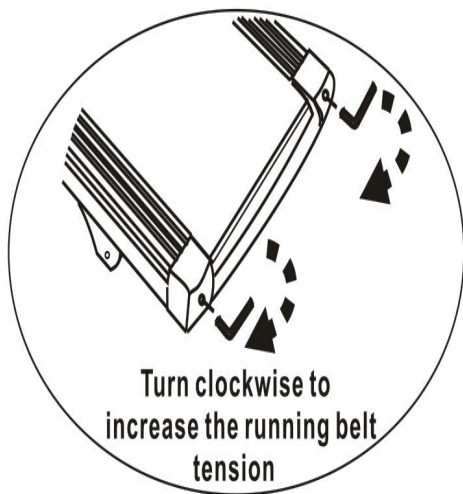

1. Start the treadmill without anyone on the running belt, press "Speed+" button until speed reaches 6 km/h.
2. Observe whether the running belt is toward the right or left side of the deck.
 - a) If towards the left side of the deck, using 6# Allen Wrench, turn the left adjustment bolt clockwise 1/4 turn and let the running belt settle into its new position; if it's still moving towards the left side, turn the bolt another 1/4 turn.
 - b) If towards the right side of the deck, using 6# Allen Wrench, turn the right adjustment bolt clockwise 1/4 turn and let the running belt settle into its new position; if it's still moving towards the right side, turn the bolt another 1/4 turn.
 - c) If the belt is still not central, repeat the above steps until the running belt is centred.
3. After the belt is centred, increase the speed to 12km/h and verify that it is running smoothly. Repeat the above steps if necessary. If the above procedure is unsuccessful in resolving the alignment, you may need to increase the belt tension.

Care and Maintenance

Motor Belt Tension Adjustment

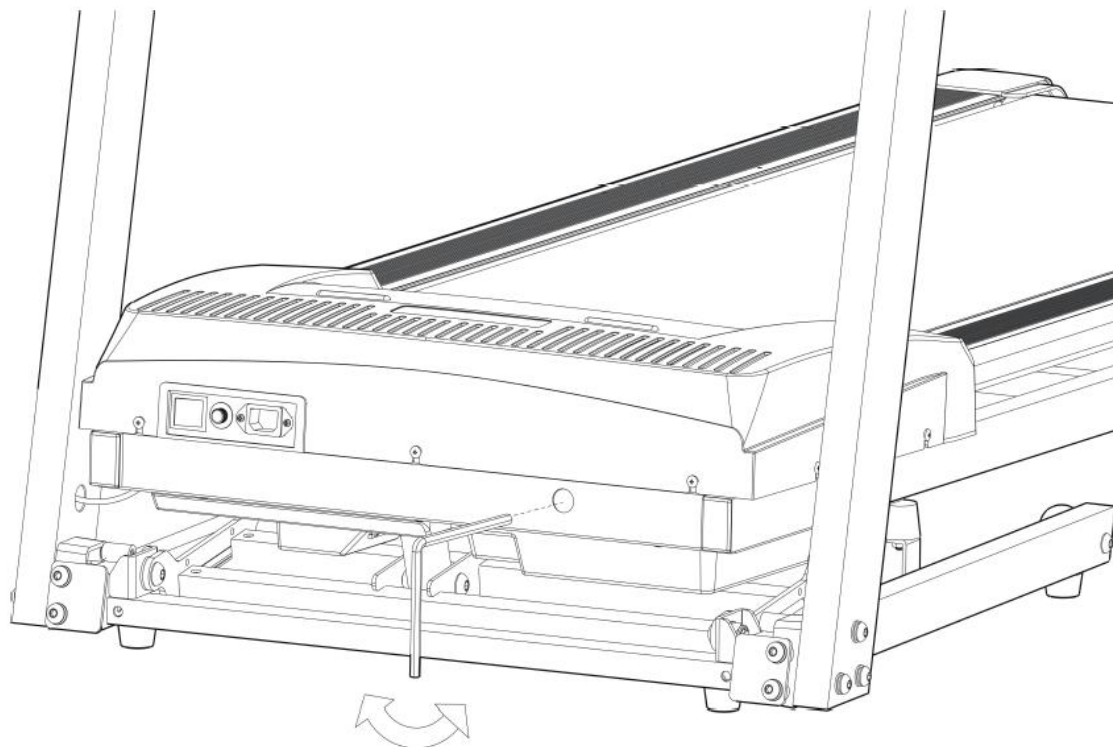

During your workout, if you find the running belt is not running smoothly, that means the motor belt is loosing, please follow the below steps to adjust the motor belt tension:

1. Turn the motor belt adjustment bolt using an M8 Allen wrench 1/4 turn in a clockwise direction.
2. Re-Start the treadmill and run on the treadmill; if the running belt is still not working properly, repeat the above step.
3. Please do not make the motor belt too tight; if the belt is over tightened it will overload the treadmill and reduce the motors life.

Care and Maintenance

Deck Lubrication

The treadmill is pre-lubricated. However, it is recommended to check the lubrication of the treadmill regularly, to ensure optimal operation.

After every 2 months of operation, lift the sides of the treadmill running belt and feel the surface of the deck, as far as possible. If traces of silicon spray are found, lubrication is not necessary. If the surface is dry, refer to the instructions below.

Only use 100% silicon oil to lubricate your treadmill deck.

To apply lubricant on the belt

- Lift the belt at one side and hold the spray valve at a distance of approximately 15cm between the running belt and the deck. Spray from the front to the rear of the deck. Repeat this process on the other side of the belt. Spray each side for about 4 seconds.
- Wait 1 minute to let the silicon spray spread, before starting the machine to circulate the oil over the running deck.

CLEANING

Regular cleaning of the belt ensures a long product life.

- **Warning:** The treadmill must be turned off to avoid electric shocks. The power cord must be pulled out of the socket, before starting the cleaning or maintenance.
- **Caution:** Do not use any abrasives or solvents. To avoid damage to the computer, keep any liquids away. Do not expose the computer to direct sunlight.
- **After each training:** Wipe the console and other surfaces with a clean soft and damp cloth to remove sweat residues.
- **Weekly:** To make cleaning easier, it is recommended to use a mat under the treadmill. Shoes can leave dirt on the belt that can fall beneath the treadmill. Clean the mat under the treadmill once a week.

STORAGE

Store your treadmill in a clean and dry environment. Ensure the master power switch is off and is un-plugged from the electrical wall outlet.

Care and Maintenance

Trouble Shooting

Error Code	Check	Solution
E00	Safety Key not in the position	Re-locate the safety key in the correct position
E01	No signal to Controller from console	A: Check the Main Controller Wire B: Replace the PCB Board
E02	Motor communication error	A: Check the wire from motor to controller B: IGBT breakdown, Replace the controller C: Check the power voltage if 50% lower than rate voltage D: replace the motor wire or motor
E04	Incline Motor communication error	A: Check the wire from incline motor to controller B: Replace the incline motor C: Replace the controller
E05	Over current protector	A: Over loading or over resistance, restart the treadmill B: Transmission parts seized up, check the parts C: Replace controller D: Motor breakdown, replace the motor
E06	Motor Open Circuit	Check the Motor wire
E08	IC Driver Error	Replace the IC driver
E09	Folding up protect	A: Do not fold up the running deck when treadmill is running B: If the running deck in laying position and show E09, replace the controller
E10	Motor instantaneous current abnormal	A: Adjust the torsion potentiometer of the Controller to lower B: Motor Breakdown, replace the motor
E11	Over voltage protector	Voltage over 270v (for 220v) or 150v (for 110v) -- turn off the treadmill and check the power source
E13	No signal to console from Controller	A: Check the Main Controller Wire B: Change the controller
E14	Lower voltage protector	Voltage lower than 160v (220v) or 70v (110v) -- turn off the treadmill and check the power source

Exploded Parts Diagram

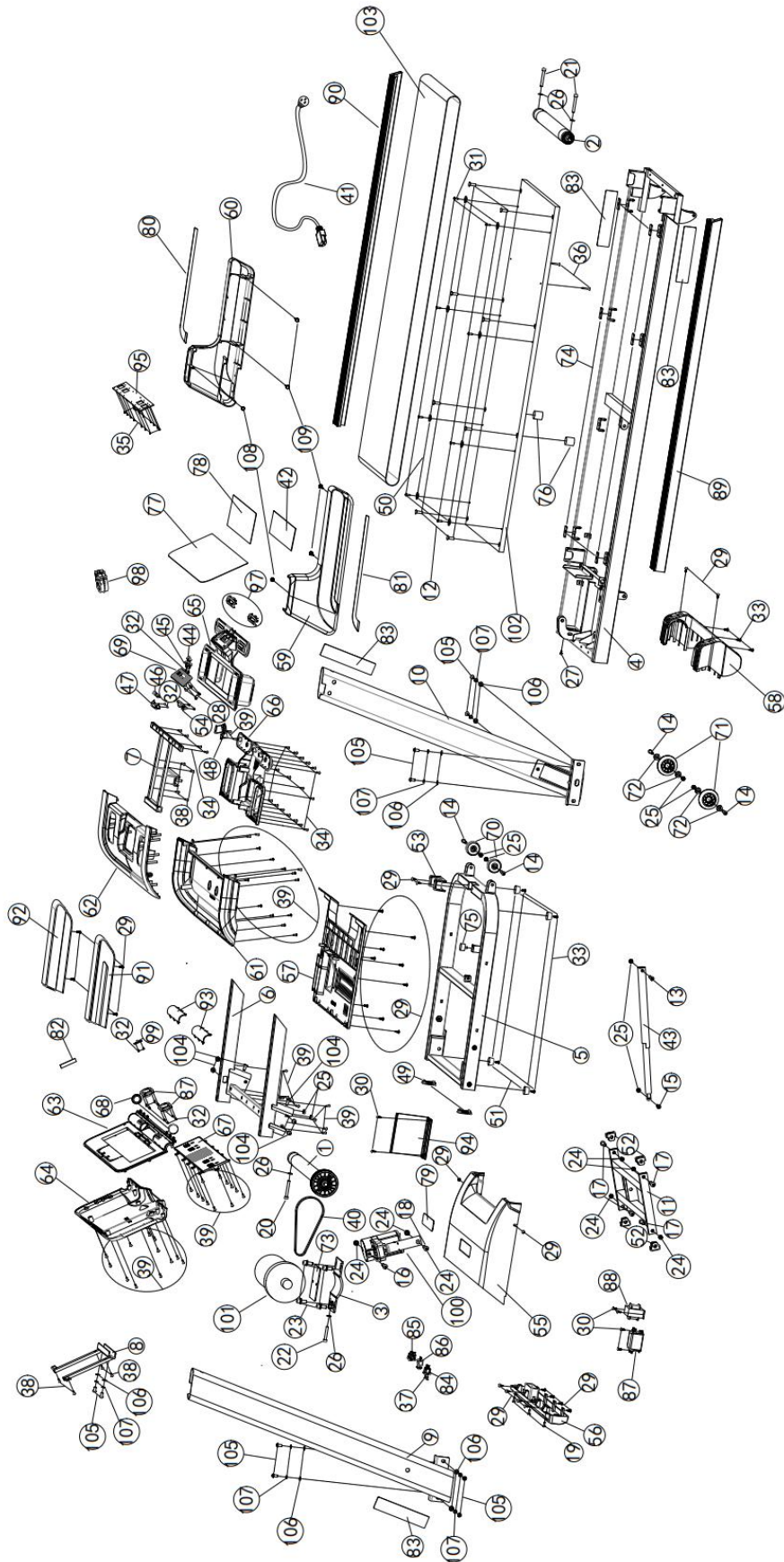

Parts List

PRO FITNESS

Key No.	Description	QTY	Key No.	Description	QTY
1	Front roller	1	28	ST4.2×10mm Large Fat head Phillips self tapping screw	4
2	Rear roller	1	29	ST4.8×15mm Large Fat head Phillips self tapping screw	30
3	Motor Support	1	30	ST4.2×15mm Large Fat head Phillips self tapping screw	6
4	Running stage	1	31	ST4.8×15mm Dome Head Phillips Screw	16
5	Base frame	1	32	ST2.9×8mm Dome Head Phillips Screw	16
6	handle	1	33	ST4.8×20mm Dome Head Phillips Screw	7
7	keyboard Support Frame	1	34	ST4.2×9mm Dome Head Phillips Screw	20
8	Console Bottom Housing Frame	1	35	ST2.2×4.5mm Dome Head Phillips Screw	15
9	Left Console Mast	1	36	ST4.2 x 30mm Sunk Self-tapping Screw	2
10	Right Console Mast	1	37	ST4.2 x 12mm Sunk Self-tapping Screw	2
11	Incline Frame	1	38	ST4.2×15mm Large Fat head Phillips self tapping screw	8
12	M8×28mm Phillips Sunk Screw	8	39	ST4.2×12mm Large Fat head Phillips self tapping screw	48
13	M8×50mm Allen Bolt	1	40	VEGA Motor belt	1
14	M8×40mm Allen Bolt	4	41	Power cord	1
15	M8×30mm Allen Bolt	1	42	Console keyboard	1
16	M10×42mm Allen Bolt	1	43	Air spring	1
17	M10×40mm Allen Bolt	4	44	Safety Key	1
18	M10×65mm Allen Bolt	1	45	Notch	1
19	M5x 15 mm Dome Head Phillips Sunk Screw	3	46	Fan Blade	1
20	M8×60mm Hexagon Socket Head Cap Screw	1	47	wind cover cap	1
21	M8×70mm Hexagon Socket Head Cap Screw	2	48	Fan mounting	1
22	M8×50mm Hexagon Socket Head Cap Screw	1	49	End Cap	2
23	M10×25mm Hexagon Socket Head Cap Screw	4	50	φ 25 × φ 15 × 5 Side rail stator	8
24	M10 locknut	6	51	Cushion	4
25	M8 locknut	8	52	End Cap	4
26	φ 8 Washer	4	53	Base frame cover	1
27	Dome Head Phillips Sunk Screw	1	54	ventilating slot	1

Parts List

Key No.	Description	QTY	Key No.	Description	QTY
55	Motor cover	1	79	stickers	1
56	Front cover	1	80	stickers	1
57	Motor bottom cover	1	81	stickers	1
58	end cap	1	82	stickers	1
59	Left Console Mast Cover	1	83	stickers	4
60	Right Console Mast Cover	1	84	power outlet	1
61	Console Rear Cover	1	85	power switch	1
62	Console Upper Housing	1	86	Overcurrent protector	1
63	Display screen Upper Housing	1	87	filter	1
64	Display screen Rear Cover	1	88	Inductance	1
65	Console keyboard	1	89	Left Side rail	1
66	Console Bottom Housing	1	90	Right Side rail	1
67	PCB Board	1	91	Left Handrail	1
68	horn net	2	92	Right Handrail	1
69	fan cover	1	93	horn net	2
70	Transport Wheel	2	94	Driving Board	1
71	Wheel	2	95	Console interior	1
72	wheel inner sleeve	4	96	Speaker	1
73	Motor damping pad	1	97	Pulse sensor	1
74	Shock pad bracket	6	98	fan	1
75	Foot Pad	1	99	Bluetooth LED panel	1
76	Rubber Cushion	2	100	Elevating motor	1
77	Display screen	1	101	Motor	1
78	stickers	1	102	Running Deck	1

Key No.	Description	QTY	Key No.	Description	QTY
103	Running belt	1	107	φ 8 Spring Washer	10
104	M8x 15mm Phillips Sunk Screw	6	108	M4*8 Flat hand screws	2
105	M8×16mm Allen Bolt	10	109	M4*40 Flat hand screws	4
106	φ 8 Washer	10			



Product Guarantee

This product is guaranteed against manufacturing defects from a period of



This product is guaranteed for twelve months from the date of original purchase. Any defect that arises due to faulty materials or workmanship will either be replaced, refunded or repaired free of charge where possible during this period by the dealer from whom you purchased the unit.

The guarantee is subject to the following provisions:

- The guarantee does not cover accidental damage, misuse, cabinet parts, knobs or consumable items.
- The product must be correctly installed and operated in accordance with the instructions contained in this manual.
- It must be used solely for domestic purpose.
- The guarantee will rendered invalided if the products is re-sold or has been damaged by inexpert repair.
- Specifications are subject to change without notice.
- The manufacturer disclaims any liability for the incidental or consequential damages.
- The guarantee is in addition to, and does not diminish your statutory or legal right.
- In the event of problem with the product with in the guarantee period call **Customer Helpline: 0345 600 1714 www.argos-support.co.uk/**

Guarantor: Argos Ltd
489 – 499 Avebury Boulevard
Central Milton Keynes
MK9 2NW

