

ORIGINAL INSTRUCTION MANUAL



McGregor 1400W HIGH PRESSURE WASHER

7605862 (Model: MPW1470)

Important - Please read these instructions fully before starting assembly

These instructions contain important information that will help you get the best from your pressure washer, ensuring it is assembled correctly and safely. If you need help or have damaged or missing parts, call the Customer Helpline on **0345 605 2062**

**AFTER SALES SUPPORT
0345 605 2062**

Contents

Safety Information.....	3
Warning Symbols	3
General safety.....	4
Personal safety.....	4
Operational safety.....	6
Maintenance and storage safety.....	7
Intended use.....	7
Service.....	8
Assembly.....	9
In the Box	10
Operating the Pressure washer.....	13
Maintenance and Repair.....	17
Storage and Transportation.....	18
Technical Data.....	20
Recycling and Disposal.....	20
Plug Replacement.....	21
Getting Help.....	22
Guarantee.....	23
Declaration of Conformity.....	24



Safety Information

Important - Please read these instructions fully before operating or maintaining

Warning Symbols

The following warning symbols appear through this manual and indicate the appropriate safety measures you should take when operating and maintaining the pressure washer.



Warning



Read the instruction manual



Conforms to all relevant safety standards.



Wear ear protections.



Disconnect the mains plug immediately if the cable is damaged, has been badly twisted or is completely cut through and in the event that the device is left unattended for a short time.



WARNING: Never direct discharge stream at persons, animals, the unit or electric components.



Appliance not suitable for connection to the potable water mains.

Water that has flown through backflow preventers is considered to be non-potable.

The appliance is not intended to be connected to the potable water mains. If necessary, please use only with a water backflow preventer or inlet hose-set approved by IEC 61770.



Double insulations, Class II appliance



Waste Disposal and Environmental Protection!

Be environmentally friendly. Return the tool, accessories and packaging to a recycling centre when you have finished with them.



Electrical machines do not belong in domestic waste.

Take the equipment to a waste disposal site. The plastic and metal parts that are used can be separated out into pure grade, which allows recycling.

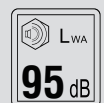

Guaranteed sound power level



Safety Information

Important - Please read these instructions fully before operating or maintaining

General Safety



IMPORTANT!

- Keep this instruction manual in a safe place for future reference.
- Read the instructions carefully. Be familiar with the controls and the proper use of the equipment.
- Never use the machine while people, especially children, or pets are nearby. Keep in mind that the operator or user is responsible for accidents or hazards occurring to other people or their property.
- This machine can be used by people with reduced physical, sensory or mental capabilities or lack of experience and knowledge if they have been given supervision or instruction concerning use of the machine in a safe way and understand the hazards involved.
- Don't use the appliance without reading the instruction sheet.
- Do not use the machine within range of persons unless they wear protective clothing.
- High pressure cleaners shall not be used by children or untrained personnel. Children should be supervised to ensure that they do not play with the machine

Personal safety



WARNING!

- Risk of fatal injury!
Use special care when cleaning tyres. Vehicle tyres/tyre valves may become damaged or burst when handled improperly. First signs of damage included discolorations on the tyre. Damaged vehicle tyres/tyre valves pose a life-threatening risk. Keep the jet at a distance of at least 30 cm!
- Never direct the jet against yourself or others in order to clean clothes or footwear.



Safety Information

Important - Please read these instructions fully before operating or maintaining

Personal Safety (continued)

- The appliance is not designed for connecting to tap water. If necessary, please use only with a water backflow preventer or inlet hose-set approved by IEC 61770.
- Risk of injection or injury, do not direct discharge stream at persons.
- Do not use the appliance when there are other people around, unless they are also wearing safety equipment.
- High-pressure jets can be dangerous if misused. The jet must not be directed at persons, animals, electrical equipment or the appliance itself.
- Know how to stop the product and bleed pressure quickly, be thoroughly familiar with the controls.
- Stay alert -watch what you are doing.
- Do not operate the product when fatigued or under the influence of alcohol or drugs.
- Keep operating area clear of all persons.
- Do not overreach or stand on unstable support. Keep good footing and balance at all times.
- Always wear appropriate personnel protection equipment (PPE) for high pressure cleaners in operation, e.g. safety boots, safety gloves, safety helmets with visors, hearing protection etc. which shall be worn while operating the equipment
- The operator or user is responsible for accidents or damages to other people or their property.

Operating Safety



WARNING!

- High-pressure hose fittings and couplings are important for the safety of the appliance.
Use only hose fitting and couplings recommended by the manufacturer.
- Inadequate extension cords can be dangerous. If an extension cord is used, it shall be suitable for outdoor use, and the connection has to be



Safety Information

Important - Please read these instructions fully before operating or maintaining

Operating Safety (continued)

kept dry and off the ground. It is recommended that this is accomplished by means of a cord reel which keeps the socket at least 60 mm above the ground.

- The electric supply connection shall be made by a qualified electrician and comply with IEC 60364-1. It is recommended that the electric supply to this machine should include either a residual current device that will interrupt the supply if the leakage current to earth exceeds 30 mA for 30 ms or a device that will prove the earth circuit.
- Disconnect from the electrical power supply before carrying out user maintenance.
- Do not use the machine if a supply cord or important parts of the machine are damaged, e.g. safety devices, high pressure hoses, trigger gun.
- If extension cable is used, the plug and socket outlet must be of a water-tight construction.
- If the supply cord is damaged, it must be replaced by the manufacturer or its service agent or a similarly qualified person in order to avoid a hazard.
- Water that has flowed through backflow preventers is considered to be non-potable.
- The PVC or polychloroprene sheathed power cord, or extension cables (H05VV-F) are acceptable for use at temperatures at or above 0 °C.
- Always switch off the mains disconnecting switch when leaving the machine unattended.
- High pressure hoses, fittings and couplings are important for the safety of the machine. Use only hoses, fittings and couplings recommended by the manufacturer.
- Never carry the appliance by the cable or the hose. Do not carry the equipment with your finger on the On/Off switch when it is connected to the mains.
- Remove the plug from the plug socket if you are not using the equipment, when transporting it or when it is left unattended, when checking the equipment, cleaning it or removing blockages, when undertaking maintenance work or changing accessories, if the power or extension cable is



Safety Information

Important - Please read these instructions fully before operating or maintaining

damaged, after contact with foreign bodies, or in the event of abnormal vibration.

- Do not use the appliance near flammable liquids or gases. In case of non-observance, there is a risk of fire or explosion.
- Ensure that the mains voltage matches the information on the label.
- Before each use, check the equipment, power cable and plug for damage, avoiding an electrical shock.
- Damaged cables, coupling and plugs or connecting leads that are not compliant with specifications are not to be used. Remove the plug from the plug socket immediately in case of damage or cutting through of the mains cable.
- Do not use the appliance when the switching action of the On/Off switch is impaired. Have damaged switches replaced at our Service Centre.
- Do not overload your appliance. Work only within the indicated range of performance. For heavy work, do not use a machine with insufficient power. Do not use your equipment for purposes other than those specified.

Maintenance and storage safety



WARNING!

- To ensure the appliance safety, use only original spare parts from the manufacturer or approved by the manufacturer.
- Retrofitting or making any unauthorized changes to the machine, as well as the use of unapproved parts will invalidate your warranty.
- Do not attempt to repair the appliance yourself. All work not indicated in these instructions is to be carried out only by service stations authorized by us.
- Store the appliance in a dry location and out of reach of children.
- Handle the appliance with care. Keep the appliance clean for safe and more efficient working. Follow the maintenance directions.



Safety Information

Important - Please read these instructions fully before operating or maintaining

Intended Use

- The appliance may be damaged by frost. There is always residual water left inside the high-pressure washer and in the pump. Do not store the machine at temperatures below freezing point in order to avoid frost damage.

This high-pressure cleaner is designed for domestic use only:

- to clean machines, vehicles, buildings, tools, facades, terraces, garden equipment etc. using a high-pressure water jet (and detergents if required).

- to use with accessories, replacement parts and detergents approved by MCGREGOR. Observe the instructions provided with these detergents.

Any use of the machine that deviates from its intended use and is not included in these instructions is considered unauthorized use and relieves the manufacturer from his or her legal liability.

Service

Have your tool repaired by an authorized service agent. This tool is manufactured in accordance with the relevant safety regulations. To avoid danger, electrical appliances must only be repaired by qualified technicians. Call our customer helpline at 0345 605 2062 for advice.

In the Box

Parts

- A High pressure washer
- B Cable storage
- C Screw x2
- D Handle
- E High pressure hose
- F Adjustable spray lance
- G Extension lance
- H Spray gun
- I Detergent bottle
- J Water inlet male connector
- K Nozzle pin
- L Instruction manual

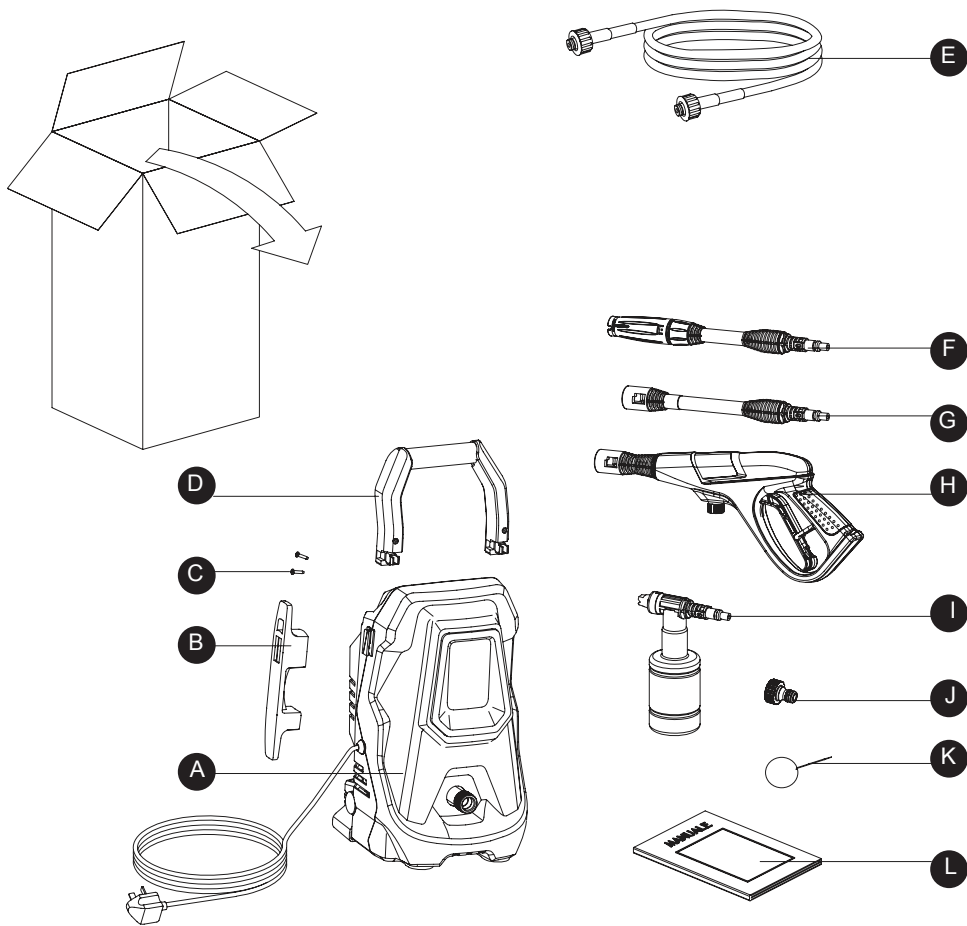

If there are any parts missing, please call the customer helpline on 0345 605 2062

Assemble

Preparing to assemble the pressure washer



IMPORTANT!

- Remove all parts of the pressure washer from the box and carefully remove all packaging. Take care not to lose any instructions which may be affixed to the parts. These provide important information which will be required while attached the pressure washer.
- Keep all packaging until the pressure washer is fully assembled and has been operated successfully.
- Always recycle the packaging in accordance with local recycling schemes.

Step 1 - Assemble the tool

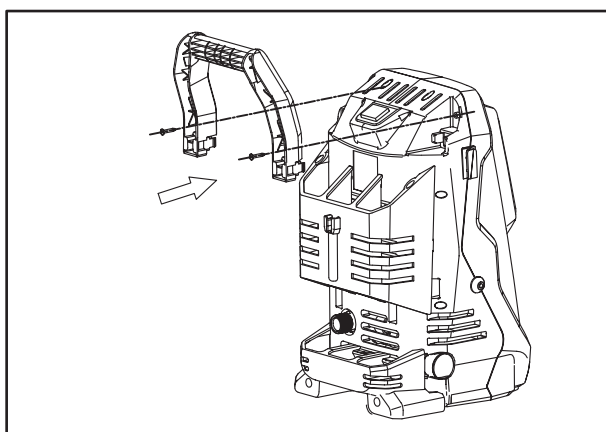

1. Assemble the handle with screw.

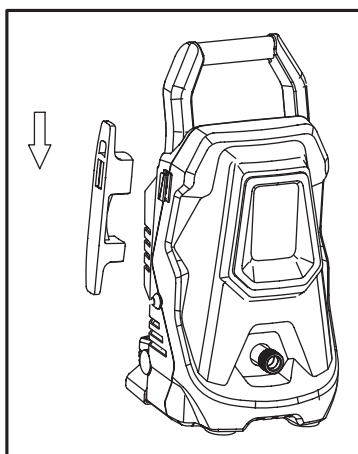

2. Fix the cable storage onto the machine

Prepare

Step 1 - Fit the high pressure hose to the washer



WARNING! Always wear safety gloves when doing any work on the pressure washer.

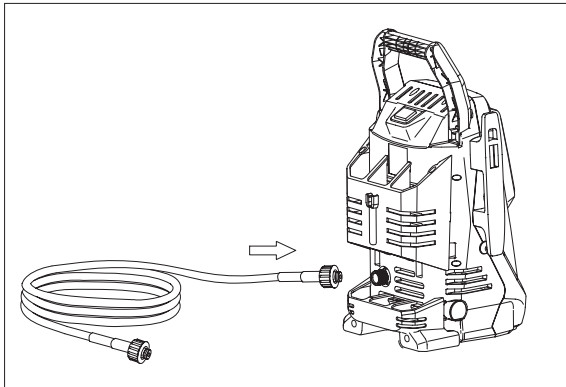

3. Connect the high pressure hose to the pressure washer. Attach high pressure hose to the machine's water outlet (hand tighten only).

Step 2 - Fit the trigger gun to the high pressure hose

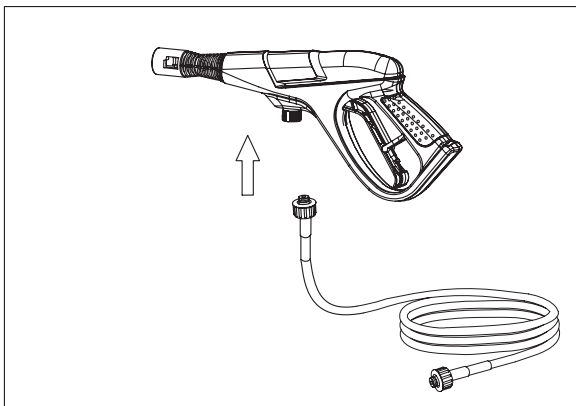

Connect the hose and trigger gun. Screw the high pressure hose firmly onto the spray gun.

Step 3 - Fit the lance to spray gun

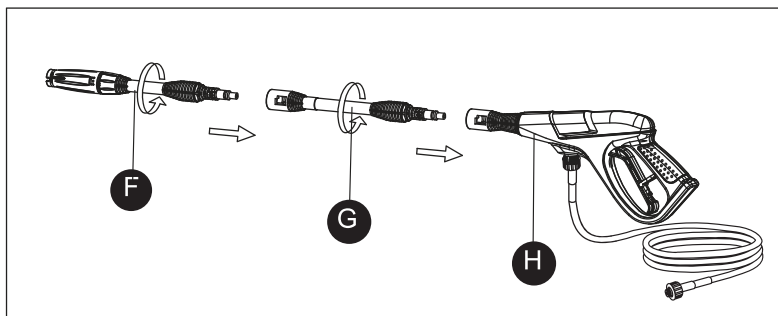

Insert the spray lance into spray gun, and twist 1/4 turn to lock in position.
NOTE! Check that it is firmly securely located in place.

Customer Helpline **0345 605 2062**

Prepare

Step 4 - Assemble inlet adapter.

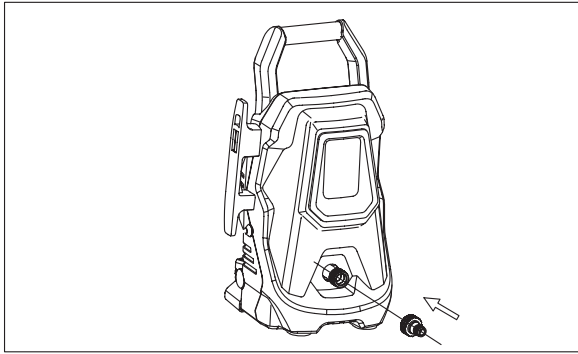

Warning: Use a water filter if using the water from a container instead of tap water.
Attach the inlet adapter to the machine's water inlet. Hand tighten only.

Step 5 - Connect garden hose and water supply.

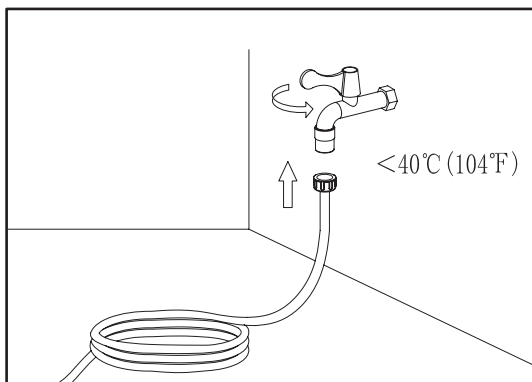

Attach garden hose to water supply and turn water on.

Step 6 - Connect garden hose and inlet adapter.

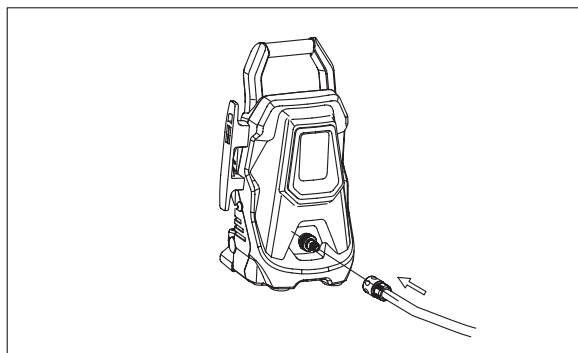

Before you attach your water hose (not included), run the water through to eliminate any air in the hose to avoid air locking. Attach the hose with a quick connect coupling (not included) to the high pressure washer.

Prepare

Step 7 - Connect socket

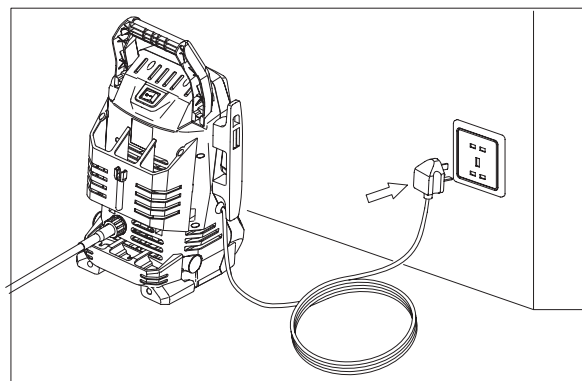
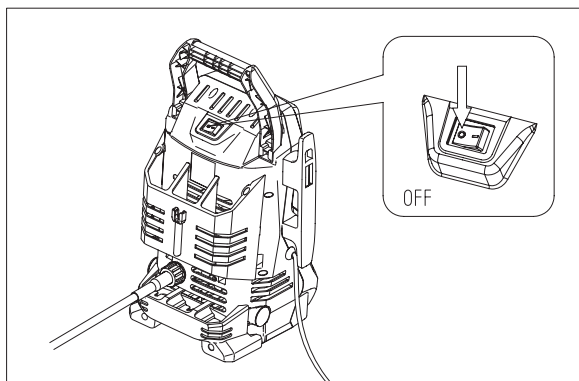

Make sure the ON/OFF switch is in the OFF position and your hands and plug are dry. Connect the plug to the mains socket.

Note! We Recommend the use of a RCD Safety protection device.

Operate

Step 1 - Starting



WARNING!

Wear suitable clothing, ears and eyes protecting when working with the equipment. Ensure that the equipment is functional before each use. Ensure that the mains voltage value matches the label on the equipment. Check the safe condition of the machine:

- Check it for visual defects.
- Check that all parts of the machine have been securely fitted.
- Check if the water connector and the high-pressure pipes are tight.

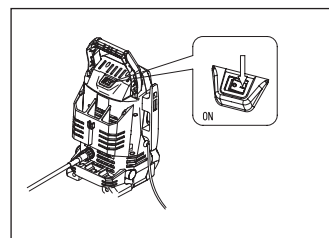
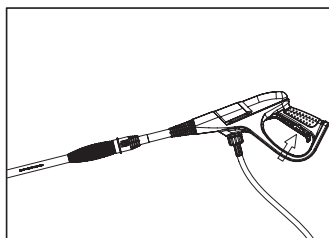
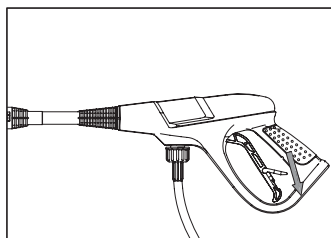

1. Place the high pressure washer on level ground. Stand in a secure and stable position.
2. Unlock the safety trigger on the spray gun, and press the trigger until there is a steady stream of water.
3. Set the On/Off switch to ON.

Operate

Step 2 - Stopping

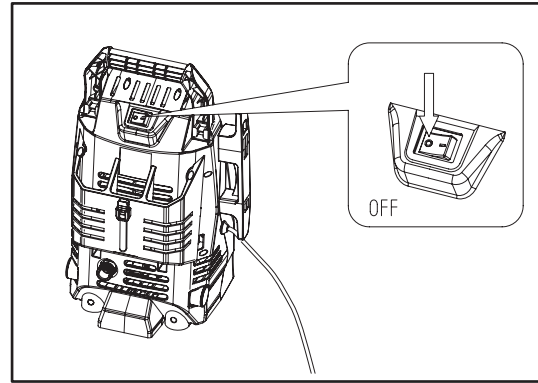
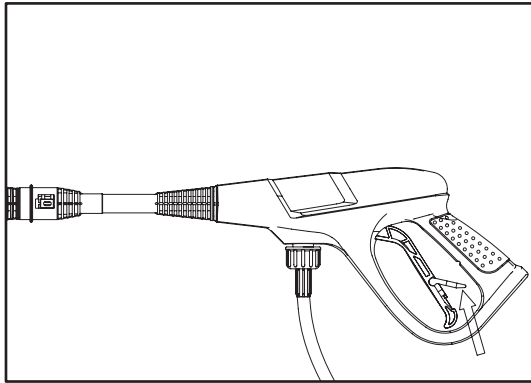

1. Release the trigger, and engage the safety lock.
2. Set the On/Off switch to OFF.
3. Close the water supply.

Step 3 – Use the high pressure lance



WARNING!

- Always turn off the machine when changing the high pressure lance.-The trigger gun is subjected to a recoil force when the water jet is discharged. Make sure that you have a firm footing and are also holding the trigger gun and spray lance with both hands.

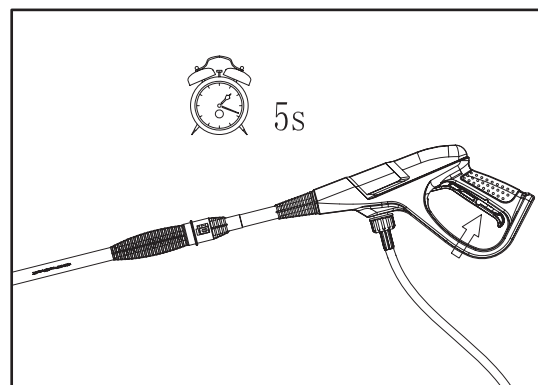
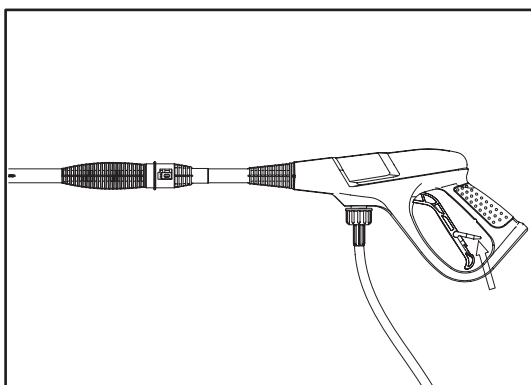

1. Hold the hand-held spray lance and the jet tube firmly with both hands. Be aware of the recoil when switching on the high-pressure jet.
2. Unlock the safety button and press the trigger on the handheld spray lance.

- It takes approximately 5 seconds to release the high pressure.
- Clogging of the spray tips causes the pump pressure to be too high and cleaning is immediately required. You can clean the spray tips by carefully inserting a using the supplied cleaning pin into the tip to remove deposits.

Operate

Step 3 – Use the high pressure lance (continued)



CAUTION!

- Jet spray adjustment is very aggressive. Do not adjust while spraying. Switch the machine off when interrupting your work for extended periods of time.
- The high-pressure pump starts running as soon as you operate the hand-held spray gun. The high-pressure pump stops running as soon as you release the trigger on the hand-held spray gun.

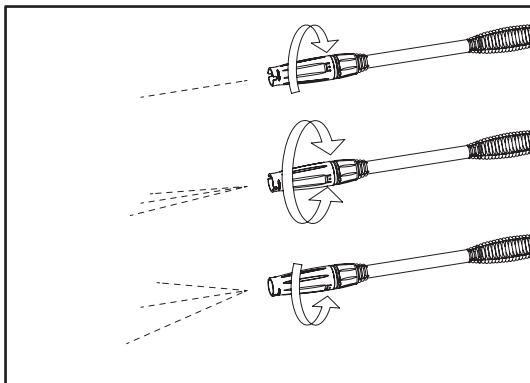

3. Use with adjustable spray lance, 180 degree rotation of the nozzle. It takes a couple of seconds for the spray to adjust to setting

The trigger gun safety lock prevents the trigger from being engaged accidentally and ensures the trigger gun cannot be locked in the ON position.

Without turning the gun, adjust the spray to desired angle by turning the nozzle with 180° marking as shown.

Operate

Step 4 – Use the detergent bottle



WARNING!

In case of contact with detergents: rinse with an abundance of clean water
Always turn off the machine when changing the detergent bottle.

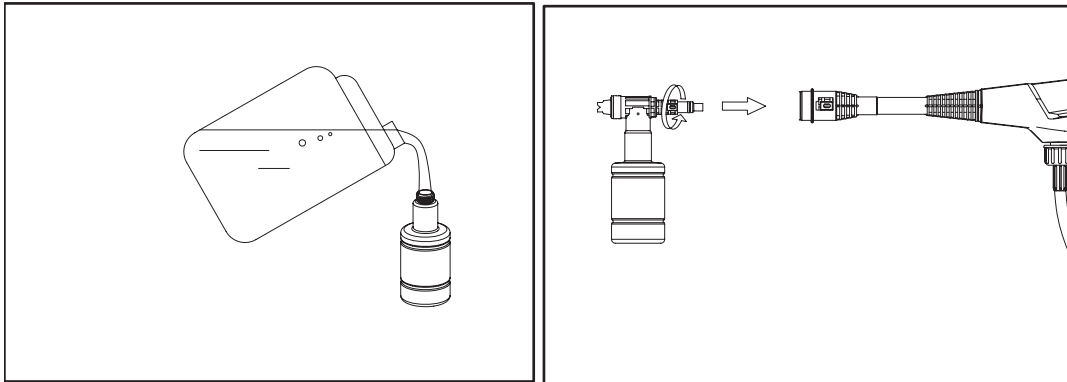

1. Unscrew the bottle cap of the detergent bottle. Fill the detergent to the detergent bottle. Screw on the bottle cap tight.
2. Fit the detergent bottle to the trigger gun.
3. Turn on the pressure washer. Pull trigger to operate unit. The liquid detergent will automatically mix with water, and be discharged through the nozzle. Apply detergent to a DRY work surface, from bottom to top.
3. Rinse with clean water under high pressure (see step 3). On a vertical surface, rinse from the bottom up, and then rinse from the top down to avoid streaking. Hold nozzle 6-8" (15-20 cm) from the work surface at a 45° angle.



NOTE:

- Allow detergent to remain on the surface for a short time before rinsing. Do not allow detergent to dry on surface
- When you have finished using the detergent injection system, fill detergent bottle with clean water. Siphon water at low pressure for one minute, so that all detergent is flushed through system. Remove detergent bottle, and rinse it until it is thoroughly cleaned.

Maintenance and Repair

Step 5 - Use the fix brush



WARNING! Always switch the product off, unplug from the power socket and let the product cool down before performing inspection, maintenance and cleaning work!

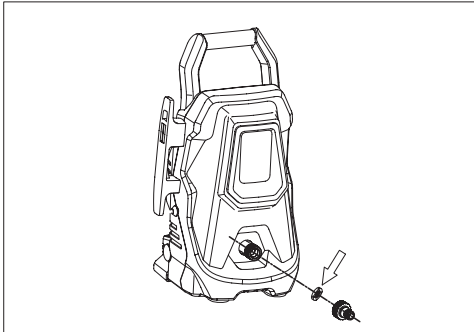

- After every use wipe the machine with a slight damp cloth. Do not clean the machine using a high-pressure water jet.
- Clean the high-pressure jet nozzle. The pressure washer is equipped with a water filter to protect the pump. If the filter is not kept clean, the water flow to the machine will be restricted and the pump may be damaged. To clean water filter, remove inlet adapter and get the filter out.
- Rinse filter until it is free of debris and blockage.
- Replace the filter and inlet adapter.

Clearing of the Lime scale

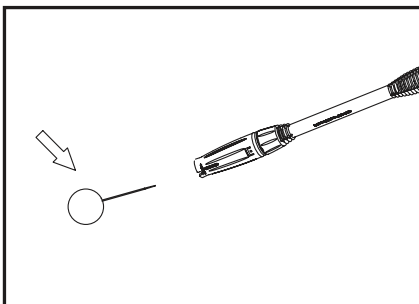

From periods of time, water lime scale may build up on your lance outlet, use the Nozzle cleaning pin to clean this away

Storing

Frost can damage your pressure washer that has not been completely emptied of water. The machine should be stored in a frost free room.

Do not kink high pressure hose.

Troubleshooting

General Troubleshooting



WARNING!

- Only perform the steps described within these instructions!

All further inspection, maintenance and repair work must be performed by an authorised service centre or a similarly qualified specialist if you cannot solve the problem yourself!

- Always turn off the machine and remove the plug before making any adjustment.

Problem	Possible cause	Solution
1. No power	<ul style="list-style-type: none"> - Check the plug socket, cable, line and plug. - Any of the parts are defective, such as On/Off switch / motor etc. (please contact service agent). 	<ul style="list-style-type: none"> - Connect to mains socket. - Check by a specialist electrician
2. The high pressure washer operates intermittently.	<ul style="list-style-type: none"> - Power cable is damaged. - Internal loose electrical connection. - On/Off switch defective (please contact service agent). 	<ul style="list-style-type: none"> - Check by a specialist electrician
3. No or only little pressure is built up.	<ul style="list-style-type: none"> - Check if there is any air in the system. - Check all inlet pipes leading to the pump for leaks or the hose is blocked or there is a kink in the pipe - Check the setting on the hand-held spray gun. 	<ul style="list-style-type: none"> - If so, please ventilate the machine! Run the machine without the high-pressure hose connected until water starts leaking without bubbles. Re-attach the high-pressure hose. - Check by a specialist electrician - Follow the Operation part again.
4. Pressure varieties	<ul style="list-style-type: none"> - Check the high pressure jet nozzle - Check the water inlet pressure. 	<ul style="list-style-type: none"> - If blocked, clean it with pin.
5. Machine is leaking.	Machine is leaking	Please contact the service agent.
6. Motor is running but no pressure is build up	You might have air locked in the hose.	Turn off machine, disconnect hose, run water through and connect again If the problem continues --then please contact the customer helpline

Technical Data

Technical Data Table

Model	MPW1470
Voltage	230-240V~ /50Hz
Input power	1400W
Working pressure	7MPa
Max pressure	10MPa
Rated flow	5l/min
Max flow	6.7l/min
Inlet T _{max}	40°C
Net weight	6kg
Measured sound pressure level	81dB (A), k=3 dB (A)
Guaranteed sound power level	95dB (A)
Vibration	1.5m/s ² , k=1.5m/s ²
P INmax	0.6MPa
Waterpro of degree	IPX5

The declared vibration value has been measured in accordance with a standard test method and may be used for comparing one tool with another. The declared vibration value may also be used in a preliminary assessment of exposure.



WARNING! The vibration emission value during actual use of the tool can differ from the declared value depending on the ways in which the tool is used. Identify safety measures to protect the operator that are based on an estimation of exposure in the actual conditions of use (taking account of all parts of the operating cycle such as the times when the tool is switched off and when it is running idle in addition to the trigger time).

The sound intensity level for the operator may exceed 85dB(A) and ear protection measures are necessary.

Recycling and Disposal

Recycling and disposal



Recycle unwanted materials instead of disposing of them as waste. All tools, hoses and packaging should be sorted, taken to the local recycling centre and disposed of in an environmentally safe way.

Recycle rather than dispose of unwanted material in landfill whenever possible. The machine must be delivered in rigid packaging to avoid damage during transportation. The packaging and the machine itself are manufactured from recyclable materials and should be disposed of accordingly.

Only dispose of electrical/electronic/battery items in separate collection schemes, which cater for the recovery and recycling of materials contained within. Your cooperation is vital to ensure the success of these schemes and for the protection of the environment.

Recycle packaging where facilities exist.

This symbol is known as the Crossed out Whee Bin Symbol. When this symbol is marked on a product or battery, it means that it should not be disposed of with your general household waste. Some chemicals contained within electrical/electronic products or batteries can be harmful to health.

Getting Help

Customer Helpline 0345 605 2062

Our dedicated UK based customer helpline is open 7 days a week to assist you with assembly, parts queries and technical support. We are open during office hours. Our experts are here to get you back enjoying your garden in no time.

Calling our service does not affect your statutory rights.

UK/Ireland 0345 605 2062

Guarantee

Dear Customer,

In the unlikely event that your device develops a fault, please contact our Customer service department on the telephone number shown below.

1. These guarantee terms cover additional guarantee rights and do not affect your statutory warranty rights. Claims must be accompanied by Proof of Purchase. This must be in the form of a Sales receipt or Bank statement and must show that the product has been purchased within 2 years prior to the claim, from the retailer that it was originally sold to.

2. Our guarantee covers problems caused by material or manufacturing defects, and will result in the repair of these defects or replacement of the device with a like for like or similar article. Please note that our devices have not been designed for use in commercial, trade or industrial applications. Consequently, the guarantee is invalidated if the equipment is used in commercial, trade or industrial applications or for other equivalent activities.

3. The following are also excluded from our guarantee :

- A. Faults due to accidents, customer misuse or unauthorized repairs
- B. Consumable Parts such as detergent bottle, patio cleaner, jet lance, fix brush and nozzle pin
- C. Failure due to lack of routine maintenance.
- D. Failure as a result of not using the equipment in accordance with the manual and safety instructions
- E. The adjustment of cables, pumps, or lances.

4. The guarantee is valid for a period of 2 years starting from the purchase date of the device. Guarantee claims should be submitted before the end of the guarantee period within two weeks of the defect being noticed. No guarantee claims will be accepted after the end of the guarantee period. The original guarantee period remains applicable to the device even if repairs are carried out or parts are replaced. In such cases, the work performed or parts fitted will not result in an extension of the guarantee period, and no new guarantee will become active for the work performed or parts fitted. This also applies when an on-site Service is used.

5. Please keep your sales receipt in a safe place. If is covered by our guarantee your device will either be repaired under the terms of guarantee or we will send you a replacement device. This device may be re-conditioned or like for like replacement .

