

# PRO FITNESS FEB2000 Folding X Bike

Assembly & User Instructions - Please keep for future reference

753/7789

**PRO FITNESS**

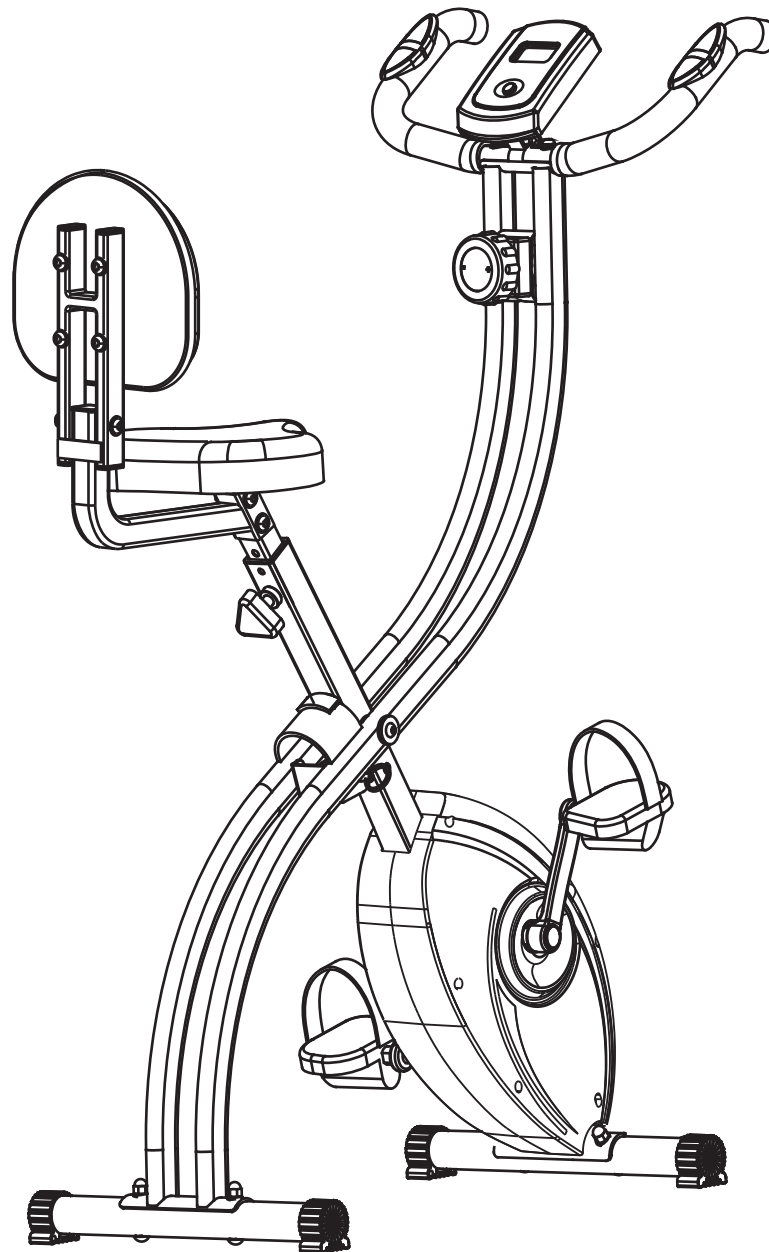

**Important – Please read these instructions fully before assembly or use**

These instructions contain important information which will help you get the best from your equipment and ensure safe and correct assembly, use and maintenance.

If you need help or have damaged or missing parts, call the **Customer Helpline: 0345 600 1714** or visit **[www.argos-support.co.uk](http://www.argos-support.co.uk)**

<b>Safety Information</b>	<b>2-3</b>
<b>Components - Parts</b>	<b>4</b>
<b>Components - Fixings</b>	<b>5</b>
<b>Assembly Instructions</b>	<b>6-8</b>
<b>Workout area</b>	<b>9</b>
<b>Exercise Information</b>	<b>10-16</b>
Before starting	10
Muscle chart	11
Warming up and cooling down	12-13
Console Operation	14
Adjustment of Resistance	15
Adjustment of Seat Height	15
Folding away your Exercise Cycle	16
<b>Care and Maintenance</b>	<b>17</b>
<b>Exploded Parts Diagram</b>	<b>18</b>
<b>Parts List</b>	<b>19-20</b>

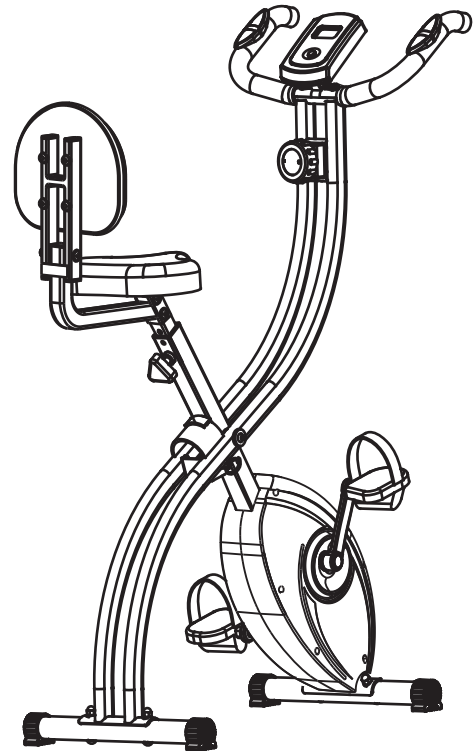



# Safety Information

PRO FITNESS

**Important – Please read fully before assembly or use**

This exercise equipment is built for optimum safety. However, certain precautions apply whenever you operate a piece of exercise equipment. Be sure to read the entire manual before you assemble, operate or use this equipment.

## Assembly

- The product must be installed on a stable and level surface. To protect the floor or carpet from damage, place a mat under the exercise bike.
- Make sure you have enough space to layout the parts before starting.
- Keep children and animals away from the work area, small parts could pose a choking hazard if swallowed.
- Dispose of all packaging carefully and responsibly.
- Check you have all the components and tools listed in the parts list, bearing in mind that, for ease of assembly, some components are pre-assembled.
- The assembly of this equipment is best carried out by 2 people.

## Using

- It is the responsibility of the owner to ensure that all users of this product are properly informed as to how to use this product safely.
- This product is intended for domestic use only. Do not use in any commercial, rental, or institutional setting.
- Use the equipment only for intended use, as described in this manual. Do not use attachments not recommended by the manufacturer.
- Keep this equipment indoors, away from moisture and dust. Do not put the equipment in a garage, outbuilding, covered patio, or near water.
- Your product is intended for use in clean dry conditions. You should avoid storage in excessively cold or damp places as this may lead to corrosion and other related problems that are outside our control.
- Keep unsupervised children away from the equipment.
- Disabled persons should not use the equipment without a qualified person or doctor in attendance.

- Always wear appropriate workout clothing when exercising. **Do not** wear loose or baggy clothing, as it may get caught in the equipment. Wear trainers to protect your feet while exercising.
- **Do not** place any sharp objects around the equipment.
- Keep hands away from all moving parts.
- If any of the adjustment devices are left projecting, they could interfere with the user's movement.
- Before using the equipment to exercise, always perform stretching exercises to properly warm up.
- Only one person at a time should use the equipment.
- If the user experiences dizziness, nausea, chest pain, or other abnormal symptoms stop the workout and seek immediate medical attention.
- Injuries to health may result from incorrect or excessive training.
- This product is suitable for a maximum user weight of: 100kg.
- This product conforms to: BS EN ISO 20957-1 and -5 Class (H) - Home Use - Class (C).
- This stationary training equipment is not suitable for high accuracy purposes.
- The braking system is adjustable.

## Battery safety

- **Warning:** Batteries are to be inserted with the correct polarity. Incorrect installation of batteries may cause battery leakage and corrosion, resulting in damage to the computer.
- **Do not** mix old and new batteries, or batteries of different types.
- **Do not** dispose of batteries in a fire.
- **Do not** dispose of batteries with normal household waste, take to a local recycling centre.
- Non-rechargeable batteries are not to be recharged.
- Rechargeable batteries are to be charged under adult supervision.
- Exhausted batteries are to be removed from the product.
- Supply terminals are not to be short-circuited.





# Safety Information

PRO FITNESS

**Important** – Please read fully before assembly or use



**Warning:** Before beginning any exercise program, consult your Doctor. This is especially important for persons over the age of 35 or persons with pre-existing health problems. You **MUST** read all instructions before using any fitness equipment. Argos and its associates assumes no responsibility for personal injury or property damage sustained by or through the use of this product. Over exercising may result in serious injury or death. If you feel faint stop exercising immediately. **Warning!** Heart rate monitoring systems may be inaccurate. For the most accurate heart rate measure, please hold both hand pulse sensors continuously during any programme.

# Components - Parts

If you have damaged or missing components, call the **Customer contact number: 0345 600 1714**

Please check you have all the parts listed below

**Note:** Some of the smaller components may be pre-fitted to larger components. Please check carefully before contacting Argos regarding any missing components.

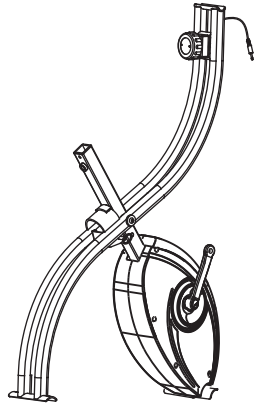

**21.** Main frame x 1

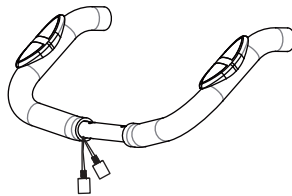

**1.** HandleBar x 1



**5.** Console x 1

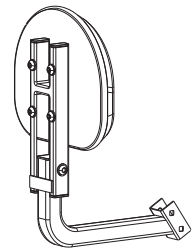

**80.** Back Rest x 1

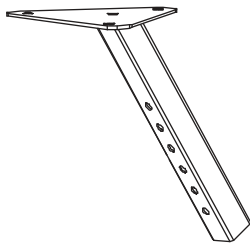

**15.** Seat post x 1

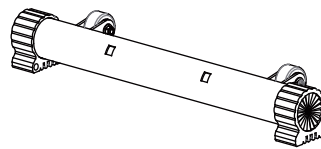

**50-1.** Front Stabilizer x 1

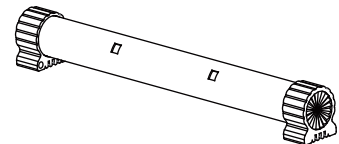

**50-2.** Rear Stabilizer x 1



**10.** Saddle x 1

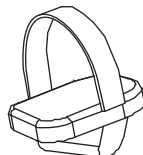

**74.** Pedal (L) x 1



**39.** Pedal (R) x 1

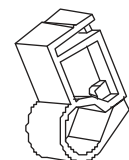







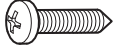

**6.** Console Holder x 1

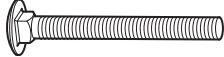
# Components - Fixings

Please check you have all the fixings listed below

**Note:** The quantities below are the correct amount to complete the assembly. In some cases more hardware may be supplied than are required. Some of the fixings are pre-fitted to the larger components. Please check carefully before contacting Argos regarding any missing fixings.

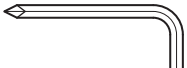
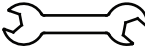
<p><b>8</b> </p> <p>M8 Spring washer x 2</p>	<p><b>11</b> </p> <p>Screw x 1</p>	<p><b>58</b> </p> <p>M8 Dome nut x 4</p>
<p><b>59</b> </p> <p>M8 Curved washer x 6</p>	<p><b>51</b> </p> <p>M8 x50mm Carriage Bolt x 4</p>	<p><b>22</b> </p> <p>Lock Knob x 1</p>
<p><b>7</b> </p> <p>M8 x 35mm Allen Bolt x 2</p>	<p><b>27</b> </p> <p>Pin x 1</p>	<p><b>77</b> </p> <p>M8 x 48mm Carriage Bolt x 2</p>
<p><b>16</b> </p> <p>M8 Curved washer x 2</p>	<p><b>17</b> </p> <p>M8 Dome nut x 2</p>	
<p></p> <p>Allen key x 1</p>	<p></p> <p>Spanner x 1</p>	

# Assembly Instructions

PRO FITNESS

Total mass of the product is 17 kg.

Total size of the equipment is (width) 41.5cm x (depth) 78.5cm x (height) 120cm.

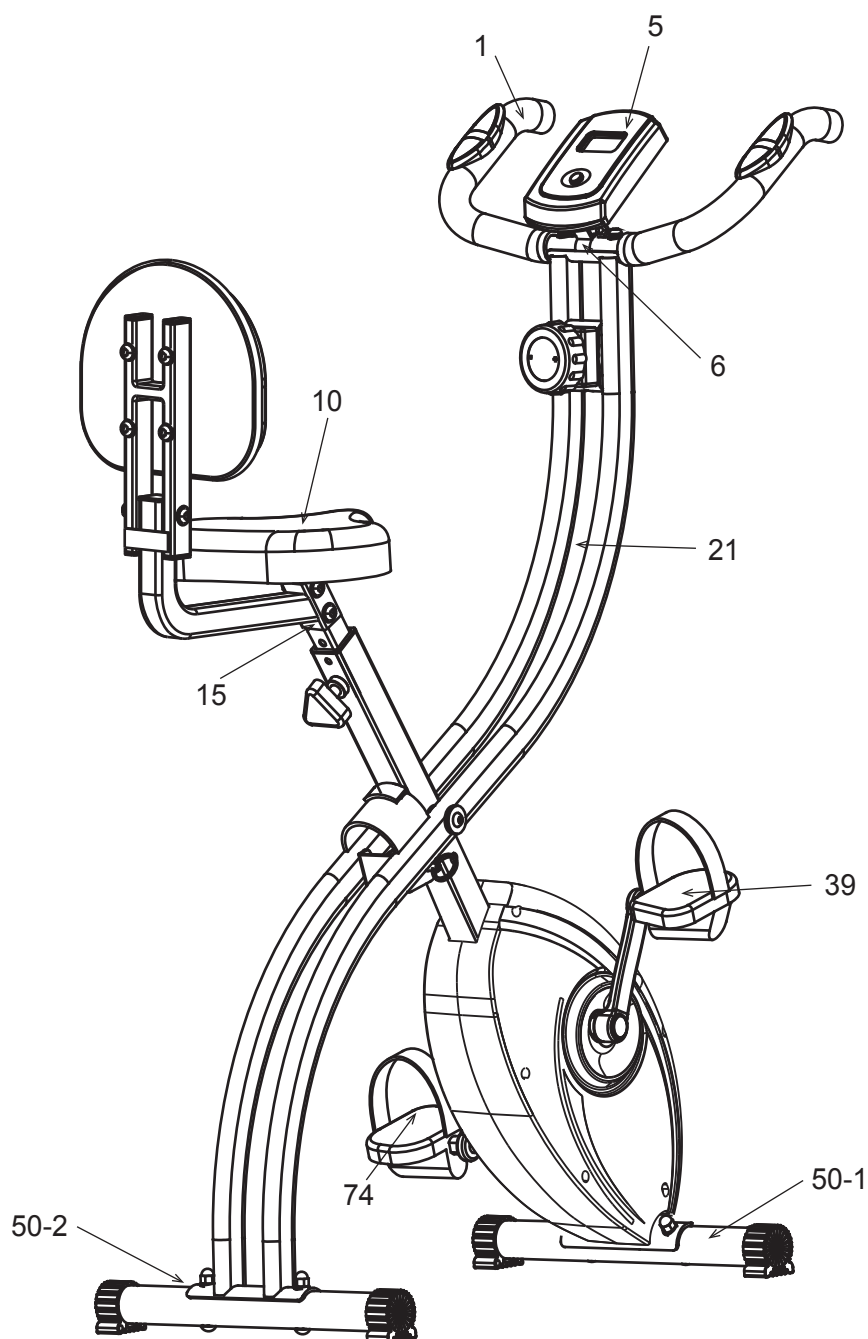

1. Handlebar

10. Saddle

39. Pedal(R)

50-2. Rear stabilizer

5. Console

15. Seat post

74. Pedal(L)

50-1. Front stabilizer

6. Console Holder

21. Main frame

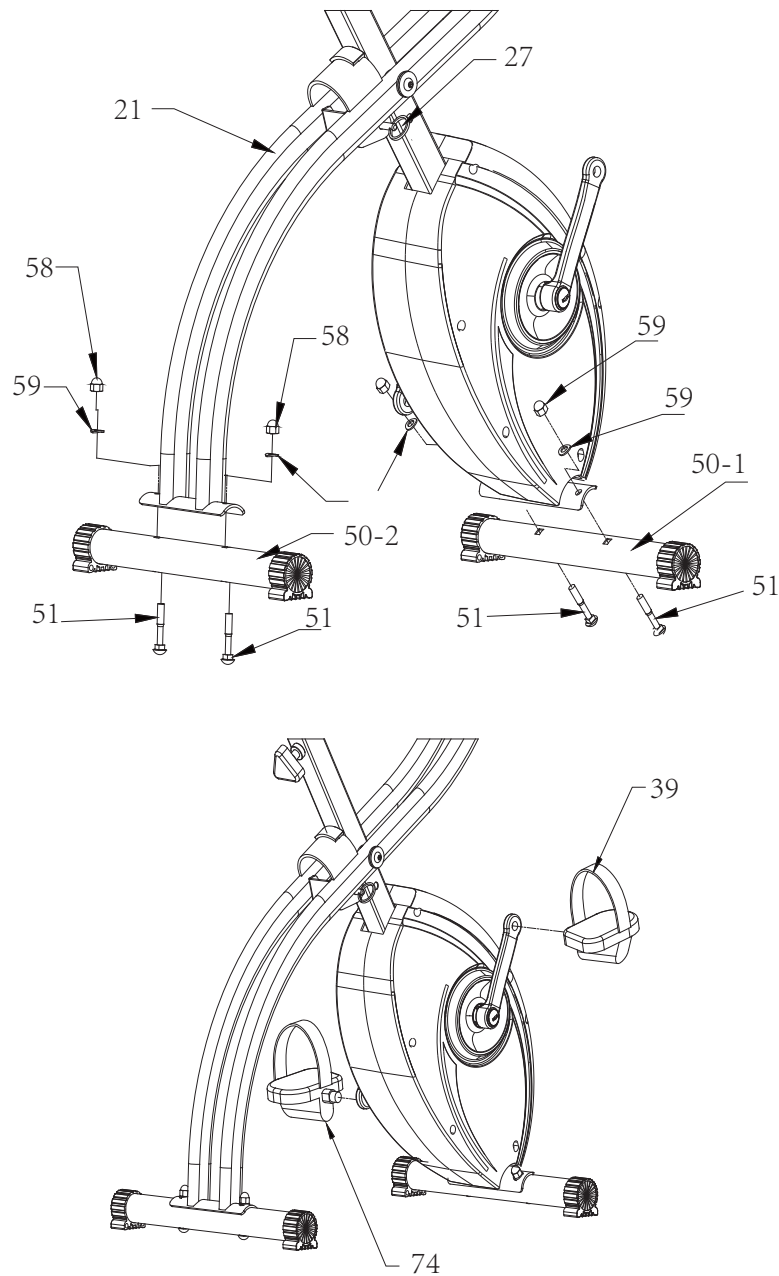

## Step 1

Unfold the Main Frame (21). Lock it into the use position with the Pin (27).

Attach the Stabilizers (50-1 & 50-2) to the Main Frame (21) using 4 x Carriage Bolt (51), 4 x Curved Washer (59) and 4 x M8 Dome Nut (58).

Note: The flat surface of the stabilizers must be placed flat horizontally on the ground.

Assemble the Left Pedal (74) and the Right Pedal (39) to the Pedal Crank. Both Pedals **MUST** be tightened securely otherwise damage may occur to the Crank.

Turn clockwise to assemble the Right Pedal (39) and counter-clockwise for the Left Pedal (74).



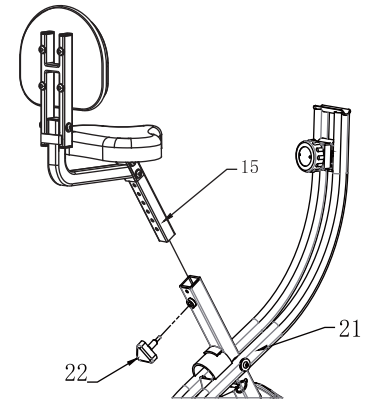
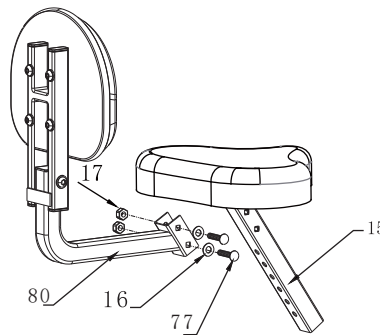
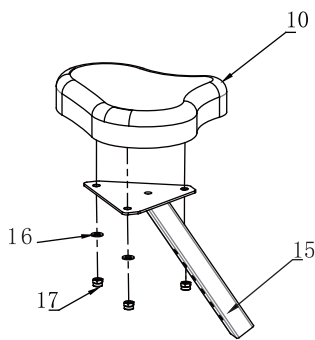

## Step 2

The 3 x M8 Nut (17) and 3 x Saddle Washer (16) are pre-assembled on the Saddle (10). Remove them before the assembly of the Saddle (10) to the Seat post (15).

Fix the Saddle (10) to the Seat post (15) by re-fitting the 3 x Saddle Washer (16) and 3 x M8 Nut (17) previously removed. Attach the Back Rest (80) to the Seat post (15) by fitting the 2 x Curved Washer (16) and 2 x M8 Dome Nut (17)

Insert the Seat Post (15) into the Main frame (21). Position the Seat Post (15) upward and downward at your required and secure with the Lock knob (22).  
Note: The seat height is correct when the knee is slightly angled with the pedal vertically down and the foot parallel to the floor.

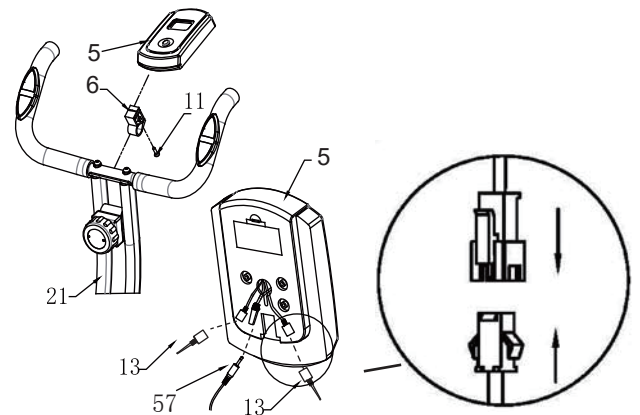
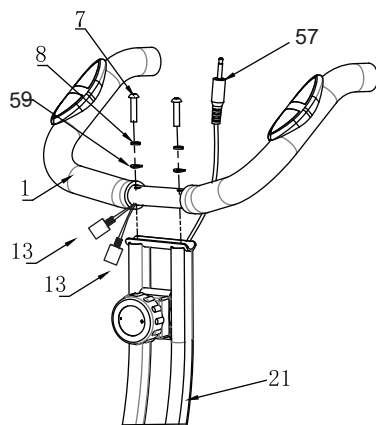

## Step 3

Connect the Handlebar (1) to the Main Frame (21) using 2 x M8 x 25mm Allen Bolt (7), 2 x M8 Spring Washer (8) and 2 x M8 Curved Washer (59).

### ATTENTION!

The Sensor Wire (57) is a single-wire and the Pulse Wire (13) is a double-wire. Please connect these wires to the wires from the back of the console (5) as shown in the diagram.

Attach the Console Holder (6) onto the Handlebar (1) and insert the Console (5) onto the Console Holder (6). Adjust the angle of the Console (5) as your desired and fix the Console Holder with Screw (11).

The free area must be at least 0.6m greater than the training area. This is a space where you can safely dismount, without obstruction, in case of an emergency. Where two pieces of equipment are positioned adjacent to each other the free area may be shared.

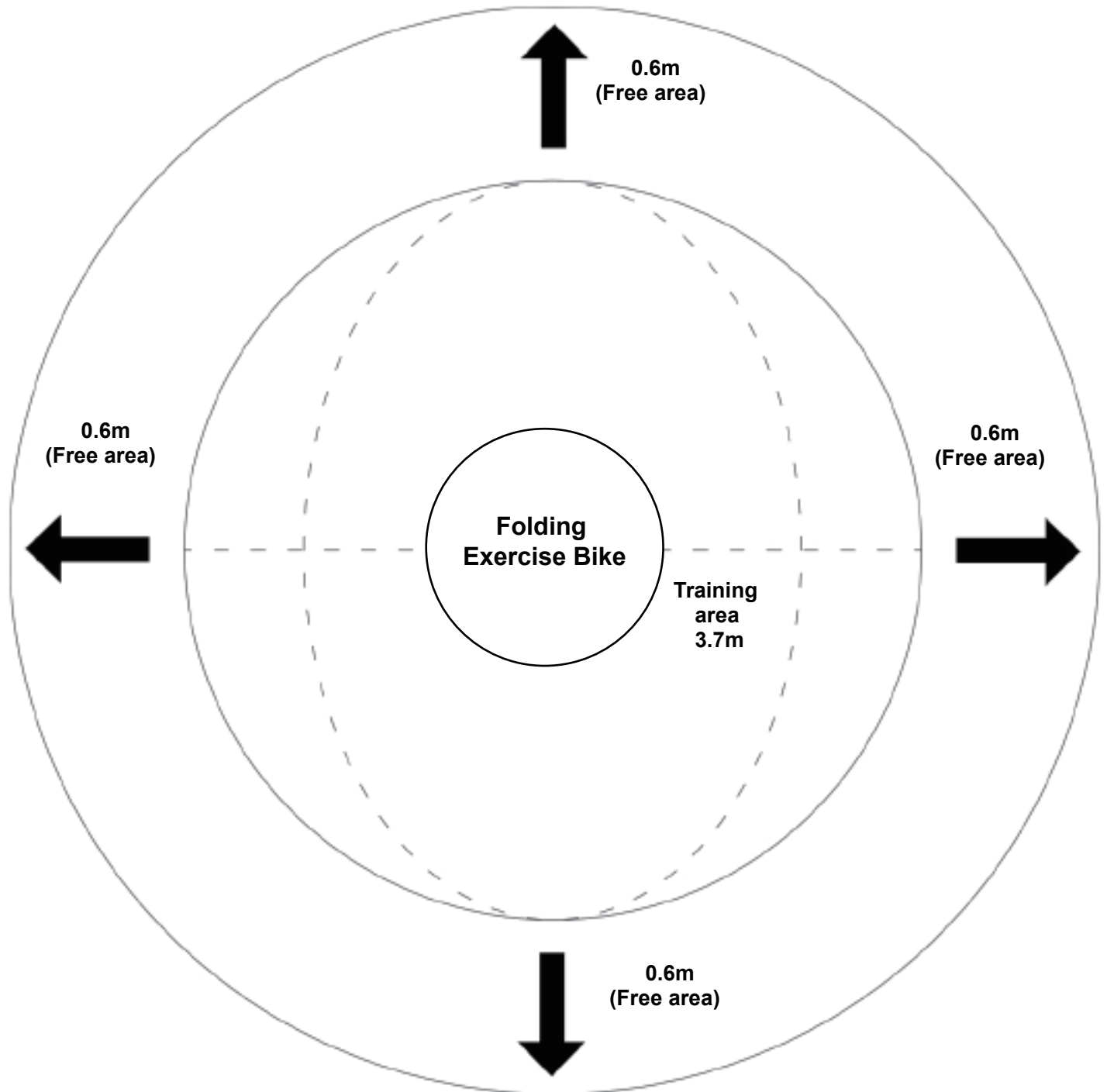

Only one person should be within the training area when the equipment is in use.

# Exercise Information

## Before starting

Tailor your exercise program according to your physical condition. If you have been inactive for several years, or are overweight, you must start slowly and increase your time on the equipment; a few minutes per workout increase is advisable.

Initially, you may be able to exercise only for a few minutes in your target zone, however, your aerobic fitness will improve over the next six to eight weeks. Don't be discouraged if it takes longer. It's important to work at your own pace.

Please remember these essentials:

- Have your doctor review your training and diet programs to advise you of a workout routine you should adopt.
- Begin your training program slowly with realistic goals.
- Monitor your pulse frequently. Establish your target heart rate based on your age and condition.
- Set up your equipment on a flat even surface with adequate training area, as prescribed in this manual.

### Exercise intensity

To maximize the benefits of exercising, it is important to exercise with the proper intensity. The intensity level can be found by using your heart rate as a guide. For effective aerobic exercise, your heart rate should be maintained at a level between 65% and 85% of your maximum heart rate as you exercise. This is known as your target zone. You can find your target zone in the table below.

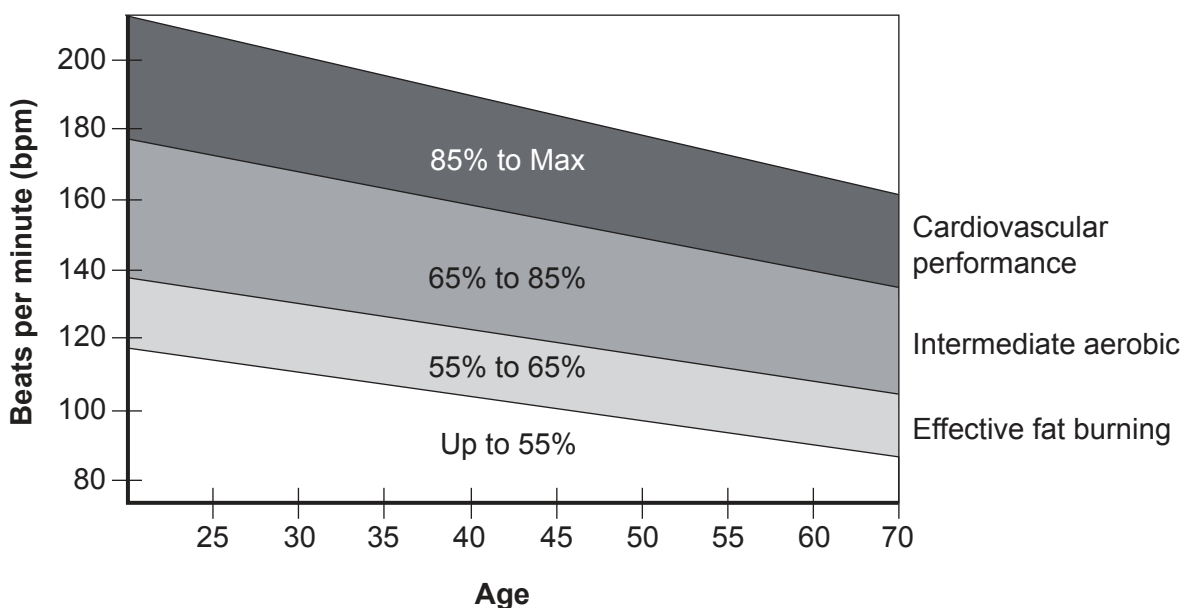

During the first few months of your exercise program, keep your heart rate near the low end of your target zone as you exercise. After a few months, your heart rate can be increased gradually until it is near the middle of your target zone as you exercise.

To measure your heart rate, stop exercising but continue moving your legs or walking around and place two fingers on your wrist. Take a six-second heartbeat count and multiply the results by 10 to find your heart rate. For example, if your six-second heartbeat count is 14, your heart rate is 140 beats per minute. (A six-second count is used because your heart rate will drop rapidly when you stop exercising.) Adjust the intensity of your exercise until your heart rate is at the required level.

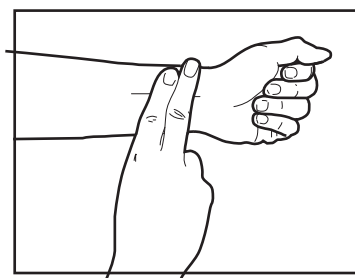

## Muscle chart

### Aerobic Exercise

Aerobic exercise improves the fitness of your lungs and heart - your body's most important muscle. Aerobic exercise fitness is promoted by any activity that uses your large muscles (arms, legs, or buttock, for example).

### Weight Training

Along with aerobic exercising which helps get rid of and keep off the excess fat that our bodies can store, weight training is an essential part of the exercise routine process. Weight training helps tone, build and strengthen muscle. If you are working above your target zone, you may want to do a lower number of reps.

### Targeted Muscle Groups

The exercise routine that is performed on the exercise bike will develop the upper and lower body muscle groups. These muscle groups are highlighted on the muscle chart below.

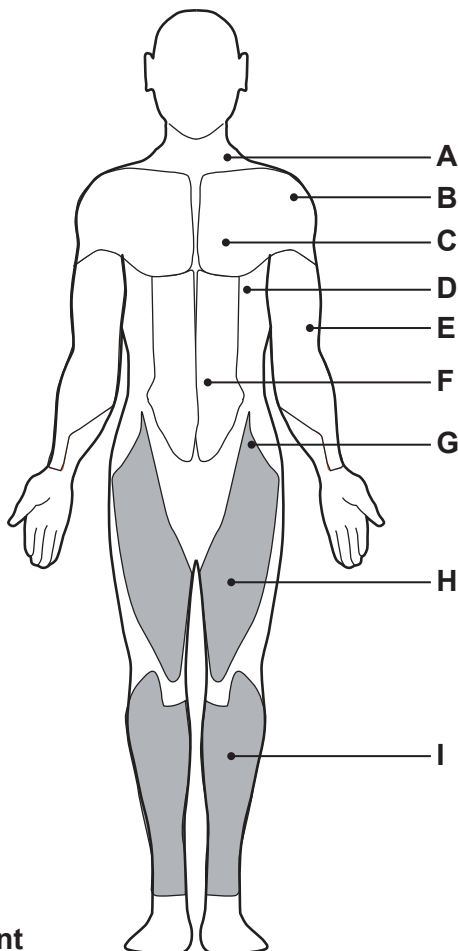

Front

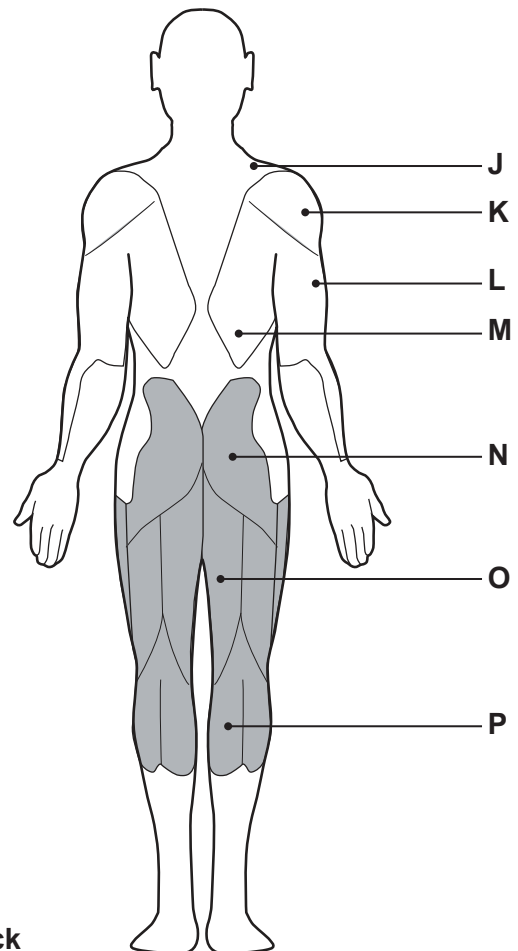

Back

- A:** Trapezius
- B:** Anterior Deltoid
- C:** Pectoralis Major
- D:** Serratus Anterior
- E:** Biceps
- F:** Abdominal
- G:** Sartorius
- H:** Quadriceps
- I:** Tibialis Anterior

- J:** Trapezius
- K:** Posterior Deltoid
- L:** Triceps
- M:** Latissimus Dorsi
- N:** Gluteals
- O:** Hamstrings
- P:** Gastrocnemius

## Warming up and Cooling down

**Each workout should include the following three parts:**

1. A warm-up, consisting of 5 to 10 minutes of light exercise. A proper warm-up increases your body temperature, heart rate, and circulation in preparation for exercise.
2. Training zone exercise, consisting of 20 to 30 minutes of exercising with your heart rate in your training zone. (**Note:** During the first few weeks of your exercise program, do not keep your heart rate in your training zone for longer than 20 minutes.)
3. A cool-down, with 5 to 10 minutes of stretching. This will increase the flexibility of your muscles and will help to reduce post-exercise muscle soreness.

### Exercise Frequency

To maintain or improve your condition, plan three workouts each week, with at least one day of rest between workouts. After a few months of regular exercise, you may complete up to five workouts each week, if desired. Remember, the key to success is make exercise a regular and enjoyable part of your everyday life.

### Suggested Stretches

For a correct warm up, see the following basic stretching exercises. Move slowly as you stretch, never bounce.

#### Toe touch stretch

Stand with your knees bent slightly and slowly bend forward from your hips. Allow your back and shoulders to relax as you reach down toward your toes as far as possible.

Hold for 15 counts, then relax.

Repeat 3 times.

**Stretches:** Hamstrings, back of knees and back.



#### Hamstring stretch

Sit with one leg extended. Bring the sole of the opposite foot toward you and rest it against the inner thigh of your extended leg. Reach toward your toes as far as possible.

Hold for 15 counts, then relax.

Repeat 3 times for each leg.

**Stretches:** Hamstrings, lower back and groin.



## Calf/achilles stretch

With one leg in front of the other, reach forward and place your hands against a wall. Keep your back leg straight and your back foot flat on the floor. Bend your front leg, lean forward and move your hips toward the wall.

Hold for 15 counts, then relax.

Repeat 3 times for each leg. To cause further stretching of the achilles tendons, bend your back leg as well.

**Stretches:** Calves, achilles tendons and ankles.

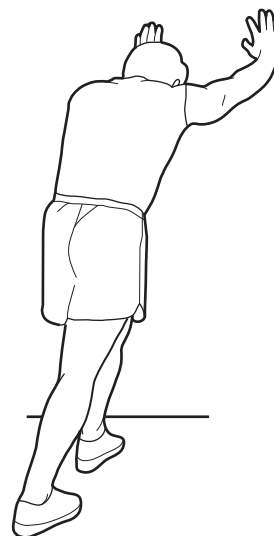

## Quadriceps stretch

With one hand against the wall for balance, reach back and grasp one foot with your other hand. Keeping your bent knee pointing directly downward towards the floor, gentle pull your heel towards your buttock until you feel a gentle stretch in the target area.

Hold for 15 counts, then relax.

Repeat 3 times for each leg.

**Stretches:** Quadriceps and hip muscles.



## Inner thigh stretch

Sit with the soles of your feet together and your knees outward. Pull your feet toward your groin area as far as possible.

Hold for 15 counts, then relax.

Repeat 3 times.

**Stretches:** Quadriceps and hip muscles.



## Console Operation

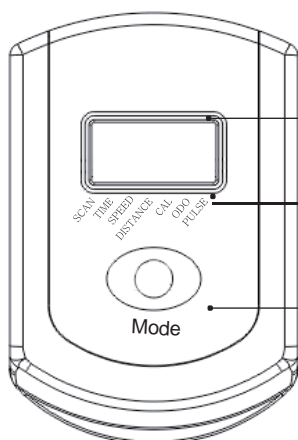

Display

Functions:

SCAN / TIME / SPEED / DISTANCE / CALORIES  
ODO / PULSE

Mode

**MODE:** Press to select the function.

**AUTO ON /OFF:** The system turns on when any key is pressed or when it receives a signal input from the speed sensor.

The system turns off automatically when the sensor has no signal input or no key is pressed for approximately 4 minutes.

**RESET:** The unit can be reset by either changing the battery or pressing the Mode key for 3 seconds.

### Functions

**SCAN:** Display the below functions in turn every 6 seconds: TIME----SPEED----DISTANCE---- CALORIES---- ODO----PULSE (repeat).

**TIME:** Workout time.

**SPEED:**Current speed.

**DISTANCE:**Workout distance.

**CALORIES:** Calories burnt.

**Pulse:** Heart Beat Rate,To get a pre-exercise pulse rate, simply hold both Hand Pulse Sensors on either side of the Handlebar Supports for 5 seconds. The Pulse Range is between 40 ~ 240 Beats per Minute.

Note: The readings displayed by the computer should not be used for therapeutic purposes as they can vary due to the sensitivity of the equipment and the available pulse signal in your palms. To get the most accurate readings, keep your hands firmly on the pulse pads for 10 to 20 seconds. **WARNING!** Heart rate monitoring systems may be inaccurate. Over exercising may result in serious injury or death. If you feel faint stop exercising immediately. For the most accurate heart rate measure, please hold both hand pulse sensors continuously during this programme

**ODO:** Accumulated distance.

cations		
<b>Function</b>	Auto Scan	Every 6 seconds
	Time	0:00-99:59 (Minute: Second)
	Speed	0.0-99.9 km/h
	Distance	0.0-999.9 km
	Calories	0-9999 Kcal
	ODO	0-9999 km
	Pulse	40-240 bpm
Battery type	2 x SIZE-AAA (not included)	
Operation temperature	0°C ~ +40°C (32°K ~ 104°K)	

## Replacing the batteries

Remove the Back Cover (A) of the Console (5) and install 2 x AAA battery (B) into the battery compartment.

Replace the Back cover (A) to the Console (5).

Note: The 2 pcs of AAA battery are not included with the equipment.

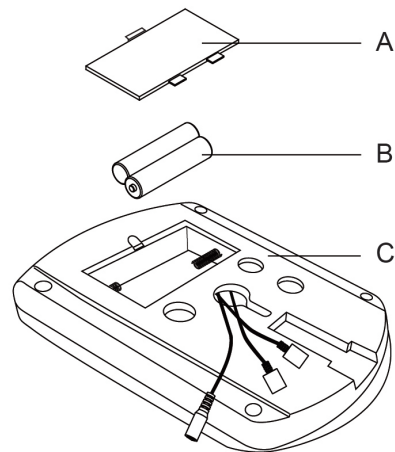

## Adjustment of Resistance

Adjustment of Resistance level by turning the 8-level tension knob either to the right (increase) or left (decrease).

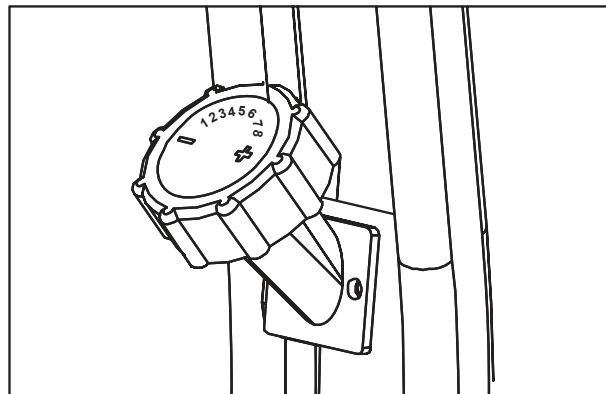

## Adjustment of Seat Height

Unlock the Lock Knob (22) and position the Seat Post (15) upwards or downwards at your required and secure with the Lock Knob (22).

Do not pull the Seat Post (15) beyond the MAX mark or below the MIN mark on the Seat Post (15).

Note: The seat height is correct when the knee is slightly angled with the pedal vertically down and the foot parallel to the floor.

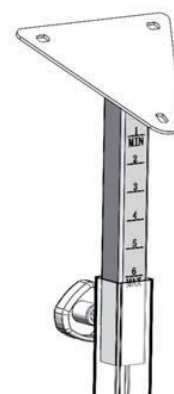
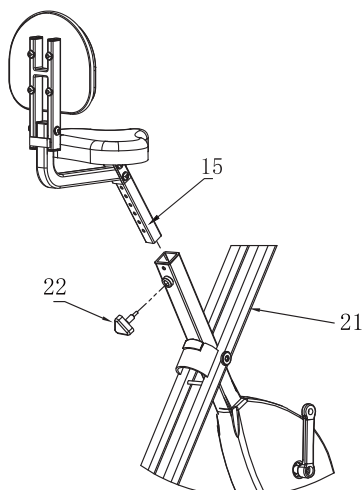



## Folding away your Exercise Cycle

Insert the Pin (27) through the holes to lock the exercise bike in folding position as shown in the below diagram.

Folded dimension of the exercise cycle is 42 x 42.5 x 138 (H) cm.

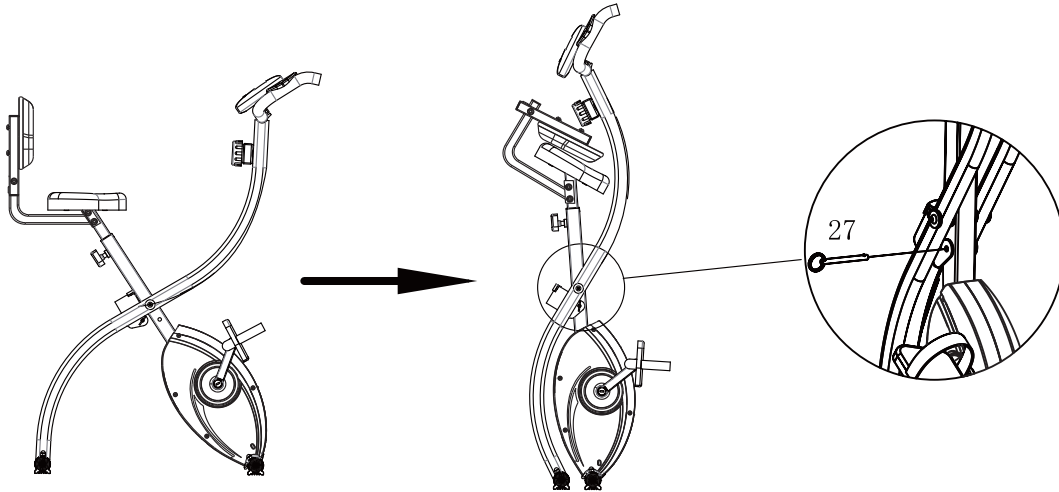

1. The safety level of the equipment can only be maintained if it is examined regularly for damage and wear e. g. ropes, pulleys and connection points.
2. Lubricate moving parts with light oil periodically to prevent premature wear. To prevent damage to the computer, keep liquids away and keep it out of direct sunlight.
3. Inspect and tighten all parts before using the equipment. Replace defective components immediately and/or keep the equipment out of use until repair. Pay special attention to components most susceptible to wear.
4. The equipment can be cleaned using a damp cloth and mild non - abrasive detergent.  
**Do not** use solvents.

5. **Do not** attempt to repair this equipment yourself. Should you have any difficulty with assembly, operation or use of your exercise product or if you think that you may have parts missing, contact the manufacturer, their approved service agent or the

**Customer Helpline:****0345 600 1714 [www.argos-support.co.uk](http://www.argos-support.co.uk)****Guarantee:****For guarantee purposes, please retain your purchase receipt.**

## Information for Users on Disposal of old Equipment and Batteries

These symbols indicate that equipment with these symbols should not be disposed of as general household waste. If you want to dispose of the product or battery, please consider the collection systems or facilities for appropriate recycling.

**Notice:** The sign Pb below the symbol for batteries indicates that this battery contains lead.

**Products****Battery**

# Exploded Parts Diagram

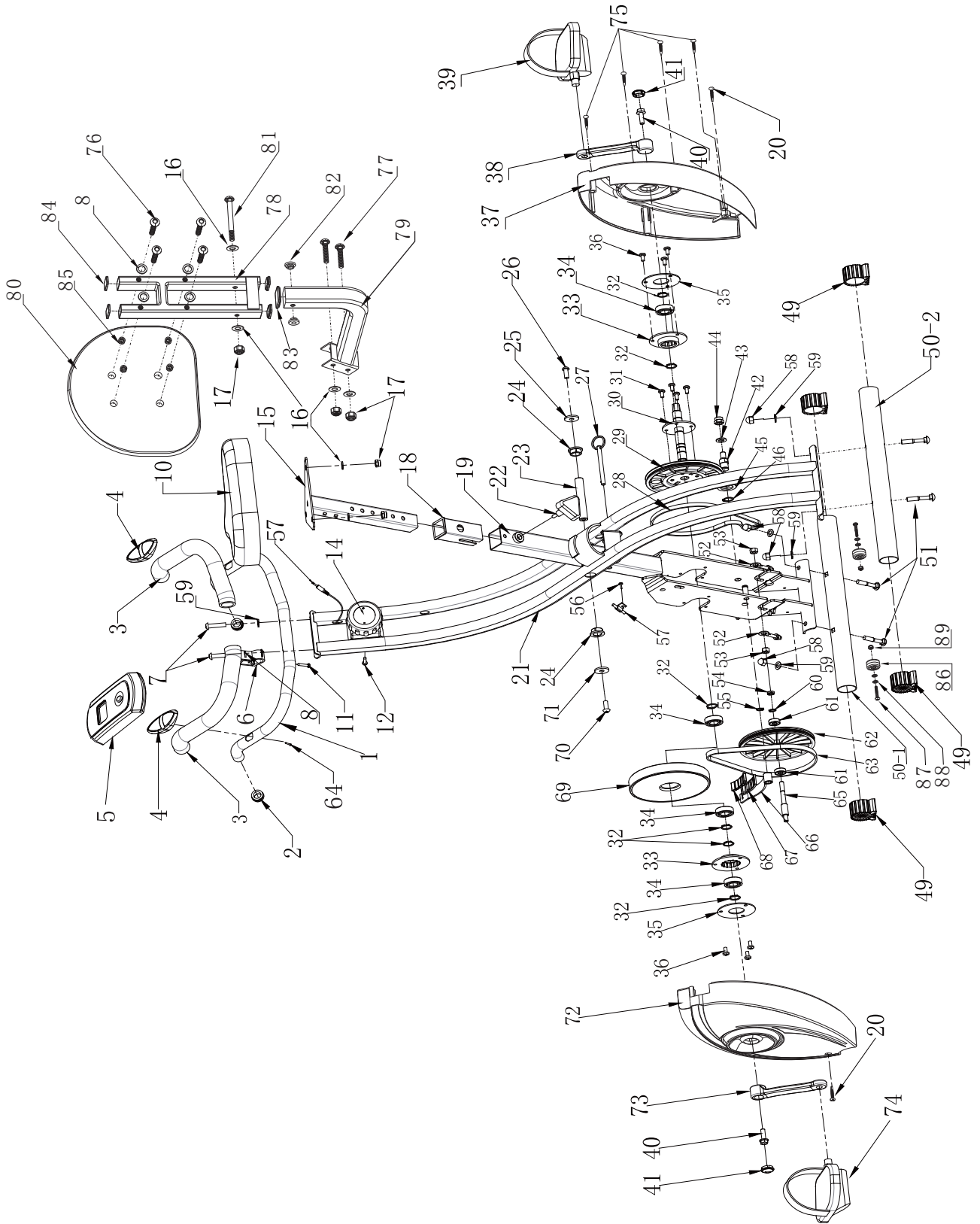

# Parts List

PRO FITNESS

Part	Description	Size/mm	Qty	Part	Description	Size/mm	Qty
1	Handlebar	Ø22XT1.2X793	1	38	Crank(R)		1
2	Handlebar cap		2	39	Pedal(R)		1
3	Foam	Ø30XØ20X342	2	40	Crank Screw	M8*25	2
4	Pulse sensor		2	41	Crank Cover		2
5	Console		1	42	Axis	Ø17*35.5	1
6	Console holder		1	43	Washer	Ø20*Ø10.2*T1.5	1
7	Allen bolt	M8*35	2	44	Nut	M10	1
8	Spring washer	Ø8.1*4.2	6	45	Axis wheel		1
10	Saddle		1	46	Shaft with elastic ring	Ø10	1
11	Screw	ST4*25	1	49	Cap		4
12	Screw	M4*25	1	50-1	Front stabilizer		1
13	Pulse wire		1	50-2	Rear stabilizer		1
14	Spout plug		1	51	Carriage Blot	M8*50	4
15	Seat post		1	52	Screw Group		2
16	Washer	Ø18*1.5	7	53	Nut	M8	2
17	Nut	M8	6	54	Nut	M8	1
18	Bushing		1	55	Shaft with elastic ring	Ø10	1
19	Driving unit frame		1	56	Sensor fixed screw	M4*8	1
20	Screw	M4x27	2	57	Sensor wire		1
21	Main frame		1	58	Dome nut	M8	4
22	Lock knob		1	59	Curved washer	Ø20*1.5	6
23	X shaft	Ø16*92	1	60	Shaft with elastic ring	Ø8	1
24	Bushing		6	51	Bearing	608	2
25	washer	Ø25*Ø8.5*T2.0	1	62	Ø 150 belt pulley		1
26	Allen Bolt	M8*15	1	63	Belt	230J	1
27	Pin		1	64	Tapping Screw	ST4*15	2
28	Belt	240J	1	65	150 Axis of belt pulley		1
29	Belt Pulley		1	66	Magnets bracket		1
30	Crank axis frame		1	67	Magnet plastic		1
31	Allen Bolt	M6*12	4	68	Magnet	18*9*5	5
32	Shaft with elastic ring	Ø17	6	69	Flywheel	Ø160	1
33	Block		2	70	Allen Bolt	M8*15	1
34	Bearing	6003	4	71	Washer	Ø25*Ø8.5*T2.0	1
35	Metal plate for reinforcing		2	72	Chain cover(L)		1
36	Allen Bolt	M6*10	6	73	Crank(L)		1
37	Chain cover(R)		1	74	Pedal(L)		1

# Parts List

PRO FITNESS

Part	Description	Size/mm	Qty
75	Screw	M4×27	4
76	Allen bolt	M8×49	4
77	Allen bolt	M8×48	2
78	H Type frame		1
79	L Type frame		1
80	Back rest		1
81	Allen bolt	M8×79	1
82	Round hole plug		2
83	Square hole plug		1
84	Square hole plug		1
85	Nut		4
86	Wheel	∅30	2
87	Allen bolt	M5×33	2
88	Washer	∅12×1	4
89	Nut	M5	2



## Product Guarantee

This product is guaranteed against manufacturing defects for a period of



This product is guaranteed for twelve months from the date of original purchase. Any defect that arises due to faulty materials or workmanship will either be replaced, refunded or repaired free of charge where possible during this period by the dealer from whom you purchased the unit.

The guarantee is subject to the following provisions:

- The guarantee does not cover accidental damage, misuse, cabinet parts, knobs or consumable items.
- The product must be correctly installed and operated in accordance with the instructions contained in this manual.
- It must be used solely for domestic purpose.
- The guarantee will be rendered invalid if the product is re-sold or has been damaged by inexpert repair.
- Specifications are subject to change without notice.
- The manufacturer disclaims any liability for the incidental or consequential damages.
- The guarantee is in addition to, and does not diminish your statutory or legal rights.
- In the event of a problem with the product with in the guarantee period call the **Customer contact number: 0345 600 1714 [www.argos-support.co.uk](http://www.argos-support.co.uk)**

Guarantor: Argos Ltd  
489 - 499 Avebury Boulevard  
Central Milton Keynes  
MK9 2NW