

Kettle BBQ with Hinge

Assembly Instructions - Please keep for future reference

7528561



Dimensions

Width - 58.0 cm

Depth - 68.0 cm

Height - 86.0 cm

Important – Please read these instructions fully before starting assembly

If you need help or have damaged or missing parts, call the **Customer Helpline: 0345 6400800**



Safety and Care Advice

Important – Read and follow instructions carefully before use.

- Failure to follow instructions could result in death, serious bodily injury and/or property loss.
- For household outdoor use only, not for commercial use.
- Some parts may have sharp edges-especially where noted in this manual.
- Wear protective gloves if necessary.
- These instructions must be kept with the consumer and retained for further use.
- Never touch metal parts which may be hot.
- Do not use or pour gasoline methylated spirits or paraffin onto burning charcoal.
- Do not use indoors.
- Do not attempt to move barbecue while in use with hot charcoal.
- Never handle charcoal or kindling wood after lighting.
- Keep small children and pets clear of this barbecue.
- For Outdoor Use Only. DO NOT use indoors. Place in well-ventilated areas.
- DO NOT use gasoline, kerosene or alcohol for lighting!
- DO NOT touch metal parts of barbecue until it has cooled to avoid burns, unless you are wearing protective gear (ex. Potholders, gloves, etc.)
- DO NOT use barbecue unless it's completely assembled and all parts are securely fastened and tightened.
- Never leave barbecue unattended during operation or cleaning.
- Never allow children to operate or play near this or any barbecue.
- DO NOT move this barbecue when in operation or hot.
- DO NOT remove the ASH-PLATE tray until coals are completely extinguished.
- WARNING! DO NOT wear loose clothing and tie back long hair around a barbecue while in use or hot.
- Keep out of reach of children & pets.
- Never take out the charcoal grid while in use.
- Always place the barbecue on level surface and far away from combustibles and children.
- DO NOT move the barbecue once the barbecue is lit.
- DO NOT use the barbecue in high wind.
- Never dismantle this appliance while in use or hot.
- DO NOT use barbecue indoors, on recreational vehicles, or on a boat.
- This barbecue is for outdoor use only and should be placed on a firm, level, fire retardant surface. The barbecue should be located in an open area with good ventilation.
- Combustible or flammable material should NEVER be used or stored within 6 feet of your barbecue.
- DO NOT use this barbecue in a fully or partially enclosed area such as garage, breezeway, carport, and porch or under a surface that can catch fire.

Assembly

- While every effort has been made in the manufacture of your barbecue to remove any sharp edge, you should handle all components with care to avoid accidental injury.
- Dispose of all packing carefully and keep out of the reach of children.
- Please read the section on barbecue safety prior to using your barbecue.

Instructions For Use

- Make sure the assembly instructions have been followed correctly.
- Set the barbecue up in a suitable position, on a level surface away from areas likely to catch fire. The base of the barbecue will get hot so ensure it stands on a suitable fire retardant surface.
- Use charcoal or kindling wood and a suitable lighting method.
- Make sure that the cooking grid is fully situated into the grid supports so that the cross bar supports lock behind the retaining edges.
- ALWAYS WEAR OVEN GLOVES WHEN HANDLING.



Safety and Care Advice

How to start your barbecue

- Make sure the assembly instructions have been followed correctly.
- Set the barbecue up in a suitable position, on a level surface away from areas likely to catch fire. The base of the barbecue will get hot so ensure it stands on a suitable surface.
- Always stand your barbecue outdoors and level ground away from trees and wooden fencing. Ensure there is at least 1 meter clearance around all sides of the barbecue, keep away from fences, over hanging branches and other combustible materials.

- Use Charcoal and a suitable lighting method:
Method 1 Charcoal & Lighting Fluid/Gel
 - a). Set up your barbecue in a safe place. Place enough charcoal in the bowl to a depth of 3.5cm.
 - b). DO NOT spill any liquid/gel onto your hands or clothes. Apply carefully the lighting fluid/gel over the charcoal.
 - c). If using lighting fluid, wait for 30 seconds to allow the liquid to soak into the charcoal.
 - d). DO NOT light the charcoal if you have spilt fluid or gel onto your clothes. Light the charcoal using a long tape or safety lighter. The charcoal will then burn for a period with flames.
 - e)When the flames die down, check the charcoal is beginning to glow red. If your coals are going out you should open all the vents and allow to cool down before trying to apply more liquid. CAUTION: Apply carefully lighting fluid/gel in small amount. Over application can be dangerous.
 - f). DO NOT squirt liquid onto burning charcoal.

- Method 2 Lighting Blocks
- a). Place three or four lighting blocks in the centre of the barbecue bowl and light with a match.
 - b). Place pieces of charcoal around each burning block. Add more charcoal as required, in a pyramid formation.
 - c). When burning is established, spread the fuel out evenly. After lighting, the fire should be ready, or when even white ash is visible by day, or an even red glow is visible by night.
- ALWAYS WEAR OVEN GLOVES WHEN HANDLING THE BARBECUE.
 - Recommend charcoal/Lighting Blocks max (**1.3** kgs) to be used.

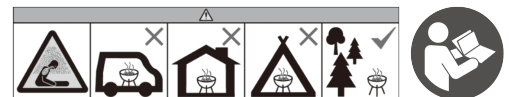

Care and Maintenance

- To make it easier to clean your barbecue after use, line the fire bowl with aluminium cooking foil, shiny side up. Remember to leave ventilation holes clear by piercing the foil where necessary. This process will lengthen the life of your barbecue.
- Charcoal is available in lump wood form (large irregular pieces) or as briquettes (uniformly sized pieces).
- It is not recommended to completely fill the fire bowl as the barbecue may become far too hot. As a guide a 3kg bag of charcoal in a 43cm (17") diameter barbecue should last for at least 2 full barbecue fires.
- If the fire flares up due to dripping fat then douse the flames lightly with a fine water spray.
- When you have finished using the barbecue, never pour cold water directly on the coals to extinguish them as this may damage your barbecue. Use old cinder, sand or a fine water spray.
- To clean your barbecue, soak the cooking grate and tools in hot soapy water as soon as possible after use. Dry thoroughly and store in a dry place. Do not leave your barbecue outside unprotected.



Safety and Care Advice

Important – Please read these instructions fully before starting assembly

- **WARNING** any braziers/barbecue should not be left unattended.
- Keep the barbecue away from homes, garages and flammable materials/ fluids or vehicles while in use.
- Barbecue is not to be used by children.
- Do not use in windy conditions.
- Use caution when using in combustible surfaces and avoid wearing flammable clothing while barbecue is in use.
- Always remember ashes can remain hot for long periods.
- Do not overload or use to burn leaves, trash or paper.
- **Use caution and heat resistance gloves when handling or moving.**
- When in use, surfaces will be hot.
- All fires must completely extinguished before retiring. Do not store hot or with ashes inside.

Variety of uses

- Patio, deck, campsite, tailgating, or in your own backyard barbecue are for outdoor use only.
- Never overload the barbecue with too many charcoals. Don't use the barbecue as an incinerator, and never burn garbage, Christmas trees, or piles of paper.
- Keep a fire extinguisher on hand. See that the extinguisher is in good working order and that all family members know how to operate it.
- Indoor use can be fatal.
- Do not use the barbecue under windy conditions, not to burn trash, leaves, cardboard in the barbecue.

Attention! This barbecue will become very hot. **DO NOT** move it during operation. **DO NOT** use indoors.

Warning! Keep children and pets away.

CAUTION! **DO NOT** use spirit or petrol for lighting or re-lighting! Use only firelighters complying to EN 1860-3.

Safety Notes

- Keep away from flammable material and fluids such as gasoline, alcohol, diesel fuel, kerosene and charcoal lighter fluid or vehicles while in use.
- Do not use flammable fluids such as gasoline, alcohol, diesel fuel, kerosene and charcoal lighter fluid to light or relight fires.
- Exercise the same precautions you use with an open fire.
- Do not allow children to use barbecue. Keep Children and pets away from barbecue.
- Do not wear flammable or loose clothing such as nylon when using barbecue.
- Do not burn trash, leaves, paper cardboard or plywood in barbecue. Avoid using soft wood such as pine or cedar that likely to top and throw sparks. Use of seasoned hardwood is suggested.
- Do not store barbecue with ashes or combustible materials inside. Do not store barbecue until the fire is completely out and all surfaces are cold.
- Use heat resistant gloves when handling barbecue and tending then fire. Use long handled, sturdy barbecue equipment when adding or moving charcoals.
- Do not move barbecue while in use.
- Always use in accordance with all applicable local and national fire codes.
- Use only on non-combustible surfaces such as concrete, brick, rock, etc.. Do not use on a wooden deck unless screens are in place and barbecue is under constant supervision. Do not leave unattended. Keep all bolts, nuts and screws tight to make sure barbecue is in safe working condition. Inspect on a routine basis to ensure your barbecue is functioning reliably.
- Stand your barbecue on a safe, level surface, away from flammable items such as wooden fences or over-hanging tree branches. **NEVER USE** your barbecue indoors or in confined areas.
- **DO NOT** use gasoline, paraffin, methylated spirit or lighter fuel to light your barbecue.
- Once lit **DO NOT** move your barbecue or leave it unattended.
- Keep children and pets a safe distance away from the barbecue.
- Keep a fire extinguisher handy.
- During use the barbecue will become hot, so only handle lids etc. with an oven gloves.
- Ensure that the barbecue has completely cooled before removing the ash.

Components

If you have damaged or missing components,
call the **Customer Helpline: 0345 6400800**

Please check you have all the components listed below.

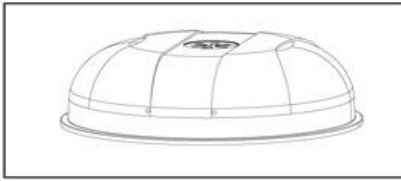

1 Grill Lid x 1

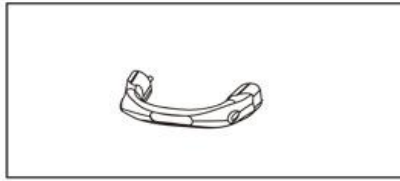

2 Handle x 2

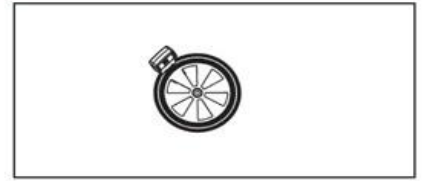

3 Lid Vent x 1

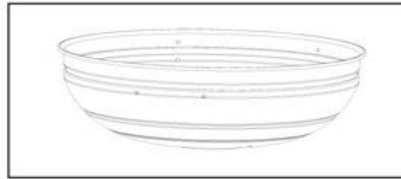

4 Grill Bowl x 1

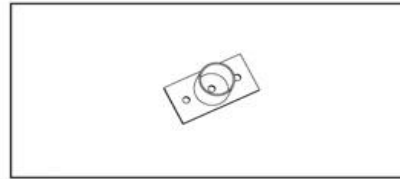

5 Leg Base x 4

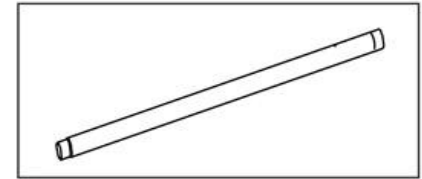

6 Fongt Leg x 2

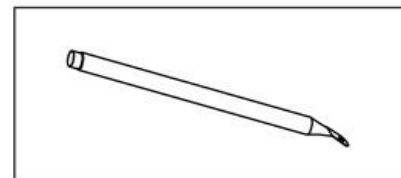

7 Wheel Leg x 2

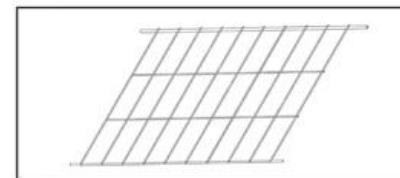

8 Bottom Grid x 1

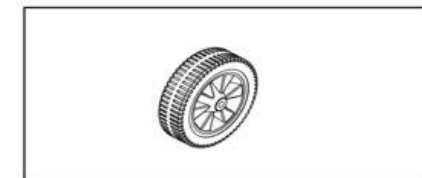

9 Wheel x 2

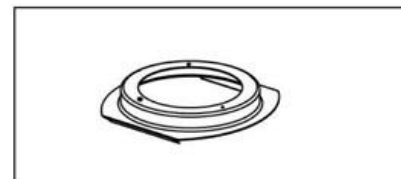

10 Ash Catcher Base x 1



11 Ash Catcher x 1

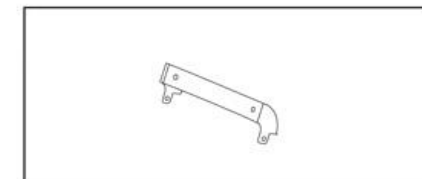

12 Lid Hinge x 1

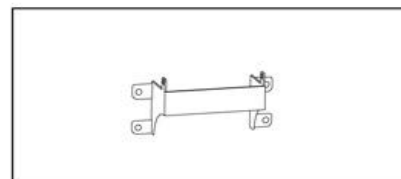

13 Bowl Hinge x 1



14 Warming Rack x 1

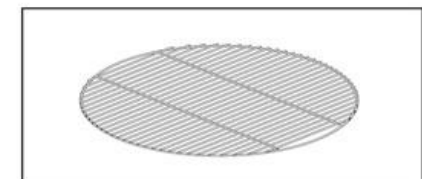

15 Cooking Grid x 1

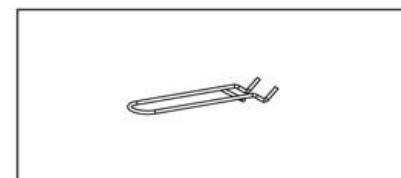

16 Cooking Grid Handle x 2

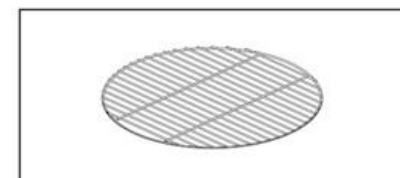

17 Charcoal Grid x 1



















18 Charcoal Window x 1

Components - Fittings

Please check you have all the fittings listed below

Note: The quantities below are the correct amount to complete the assembly. In some cases more fittings may be supplied than are required.

<p>A </p> <p>M5 x 12 Screw x 5</p>	<p>B </p> <p>M6 x 12 Screw x 14</p>	<p>C </p> <p>M6 x 20 Screw x 4</p>
<p>D </p> <p>M8 Lock Nut x 2</p>	<p>E </p> <p>M5 Wing Nut x 1 Will be Pre-Installed to P</p>	<p>F </p> <p>M6 Cap Nut x 2</p>
<p>G </p> <p>M6 Wing Nut x 4</p>	<p>H </p> <p>Ø13 x φ 6 Washer x 2</p>	<p>I </p> <p>Ø18 x φ 8 Plastic Washer x 2</p>
<p>J </p> <p>Ø19 x φ 6 Washer x 4</p>	<p>K </p> <p>M6 Lock Washer x 14</p>	<p>L </p> <p>M5 Nut x 3</p>
<p>M </p> <p>Ø16 x φ 6 Washer x 18</p>	<p>N </p> <p>M6 Nut x 14</p>	<p>O </p> <p>M5 Lock Washer x 3 1 ps will be Pre-Installed to P</p>
<p>P </p> <p>M5 x 10 Screw x 1</p>		

Tools required

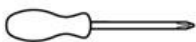

Phillips screwdriver
(medium & large)



Adjustable wrench

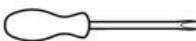

Flatblade screwdriver
(medium)



Pliers

Ruler - Use this ruler to help correctly identify the screws



Assembly Instruction

Step 1

Place Grill Lid **1** on its side and attach one Handle **2** using two M6 Wing Nut **G** Lock Washer **K** and $\varnothing 16$ Washer **M**. Tighten securely with Pilers. Attach one Lid Hinge **12** to Grill Lid **1** using two M6 x 12 Screw **B**, $\varnothing 16$ Washer **M**, M6 Lock Washer **K**, M6 Nut **N**, as shown. Attach Lid Vent **3** to Grill Lid **1** using one M5 x 10 Screw **P**, M5 Lock Washer **O** and M5 Wing Nut **E**. Tighten securely

Do not turn four M6 x 12 Screw **B tight at this time. Leaving hardware loose for now will help make the following steps easier. The Lid Vent **3** must not be overtight in order to allow move freely**

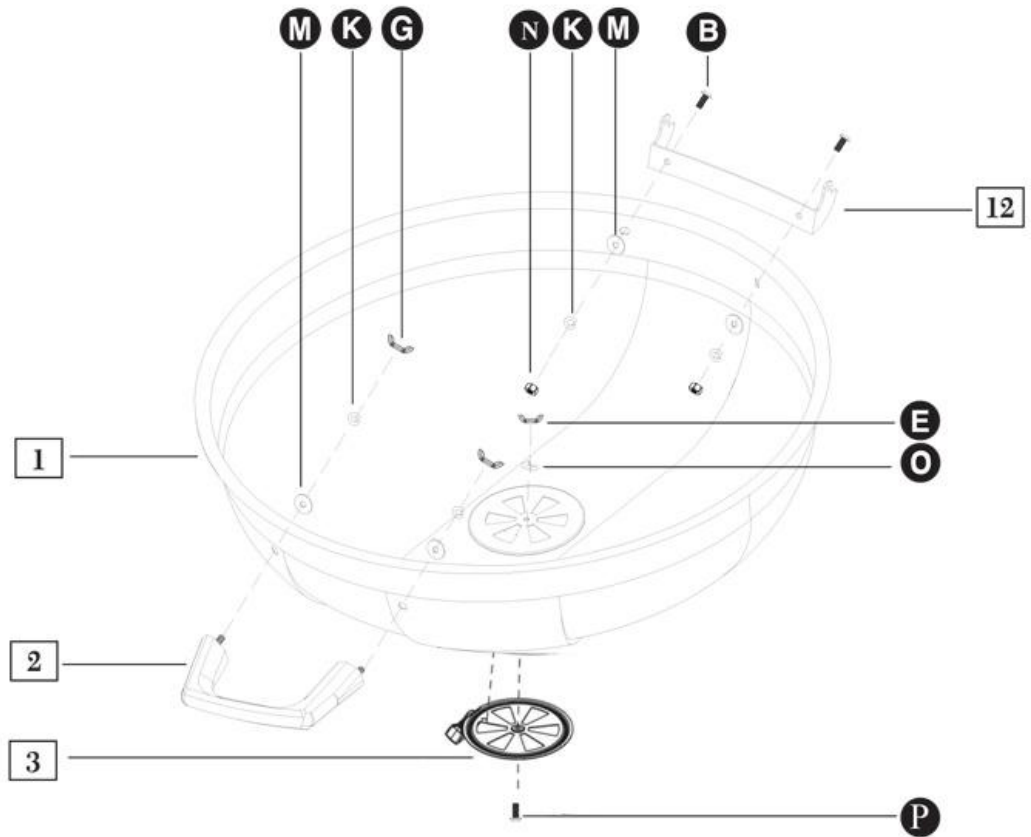

Step 2

Place Grill Bowl **4** on its side and attach four Leg Base **5** using eight M6 x 12 Screw **B**, $\varnothing 16$ Washer **M** and M6 Nut **N**, as shown. Tighten securely with Phillips head screwdriver.

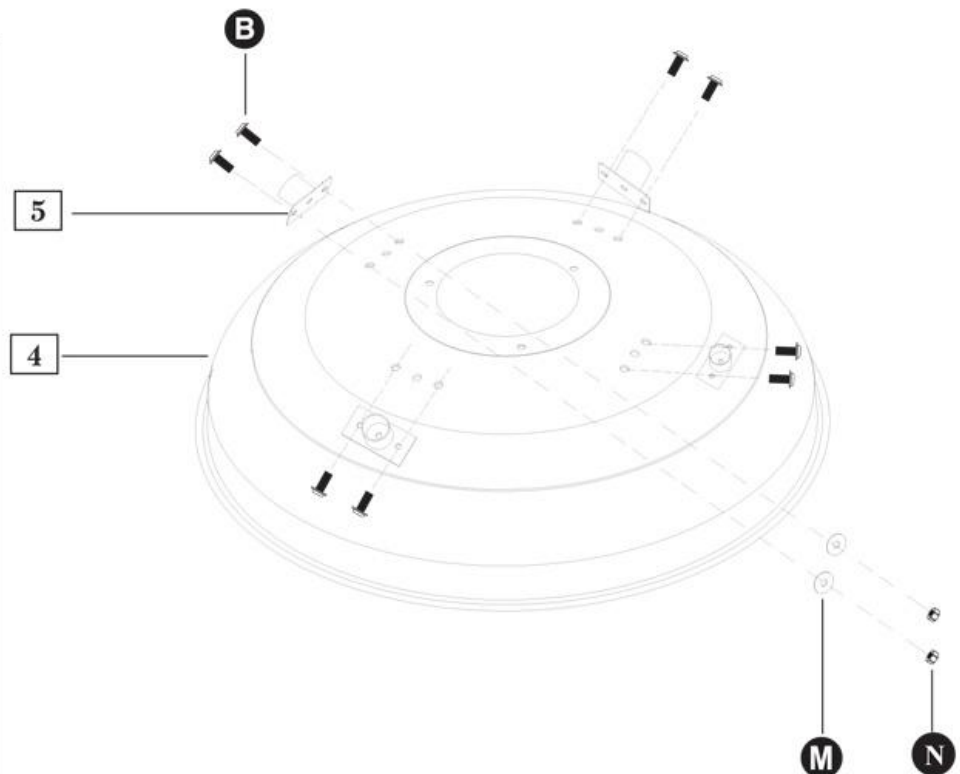

Assembly Instruction

Step 3

Place Grill Bowl [4] on its side and attach one Handle [2] using two M6 Wing Nut [G], Lock Washer [K] and Ø16 Washer [M]. Tighten securely with Pliers. Attach one Bowl Hinge [13] to Grill Bowl [4] using four M6 x 12 Screw [B], Ø16 Washer [M], M6 Lock Washer [K] and M6 Nut [N], as shown.

Do not turn four M6 x 12 Screw [B] tight at this time. Leaving hardware loose for now will help make the following steps easier.

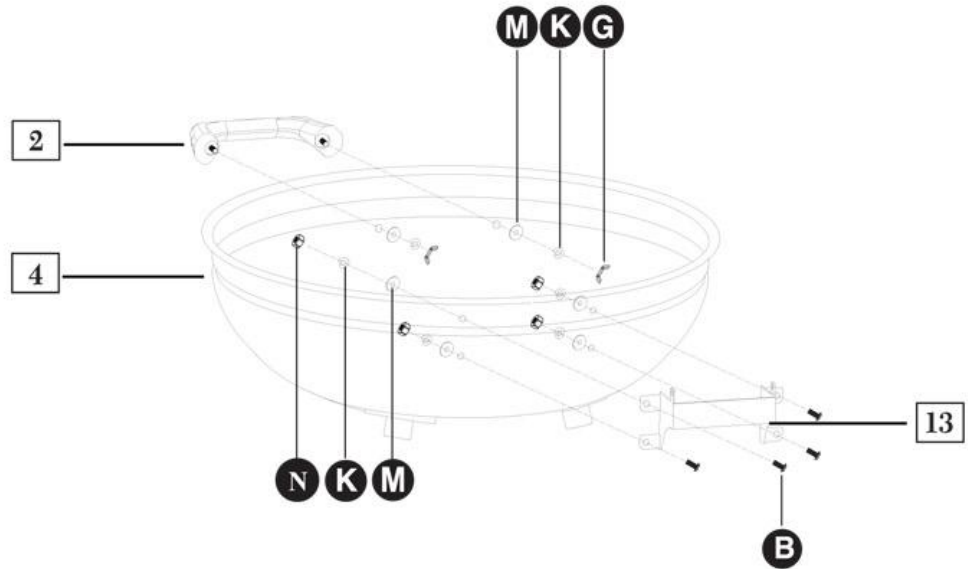

Step 4

Place Grill Bowl [4] on its side and attach two Front Leg [6], and two Wheel Leg [7] into Leg Base [5] as shown, using four M6 x 20 Screw [C], M6 Lock Washer [K] and Ø19 Washer [J] as shown. And then insert Bottom Grid [8] into two Front Leg [6], two Wheel Leg [7] as shown; and attach two Plastic Washer [I] with two Wheel [9] using two Lock Nut [D] as shown; and then using M6 Cap Nut [F] and M6 x 12 Washer [H] as shown.

Tighten securely all Screws/Nuts with Phillips head screwdriver and adjustable Wrench.

**Wheels Lock Nuts must be tightened
But do not overtight in order to allow wheels move freely.**

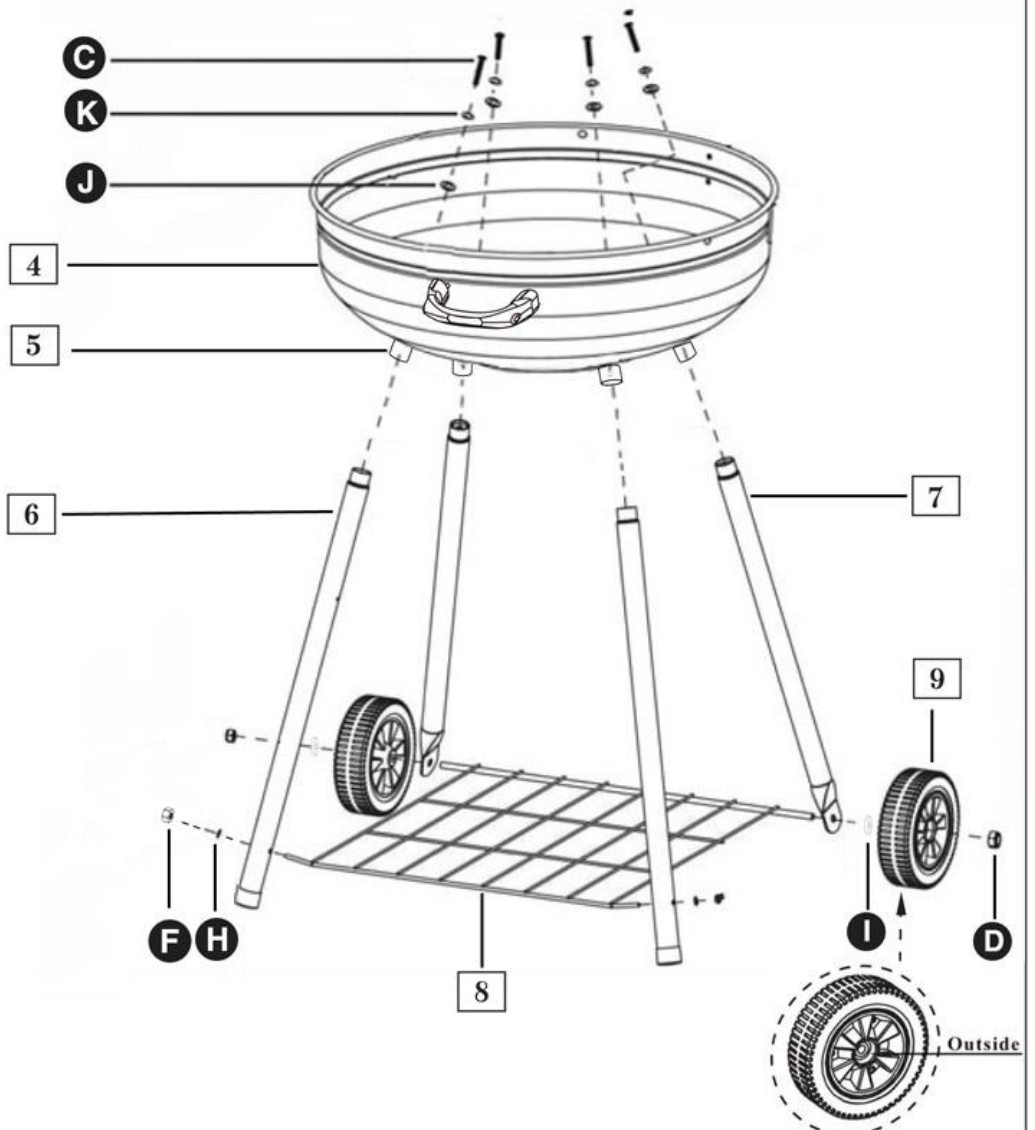

Assembly Instruction

Step 5

Place Grill Bowl **4** on its side and attach Ash Catcher Base **10** using three M5 x 12 Screw **A** and M5 Nut **L** as shown. Tighten securely with Phillips head screwdriver.

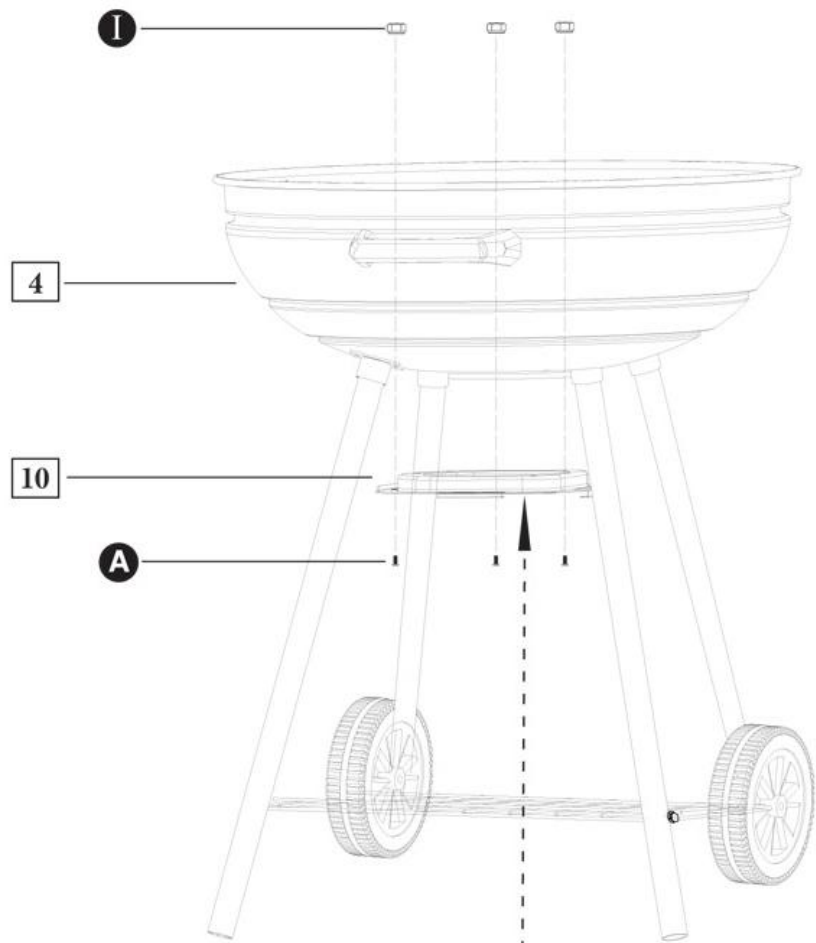

To ensure
this hole face rearward

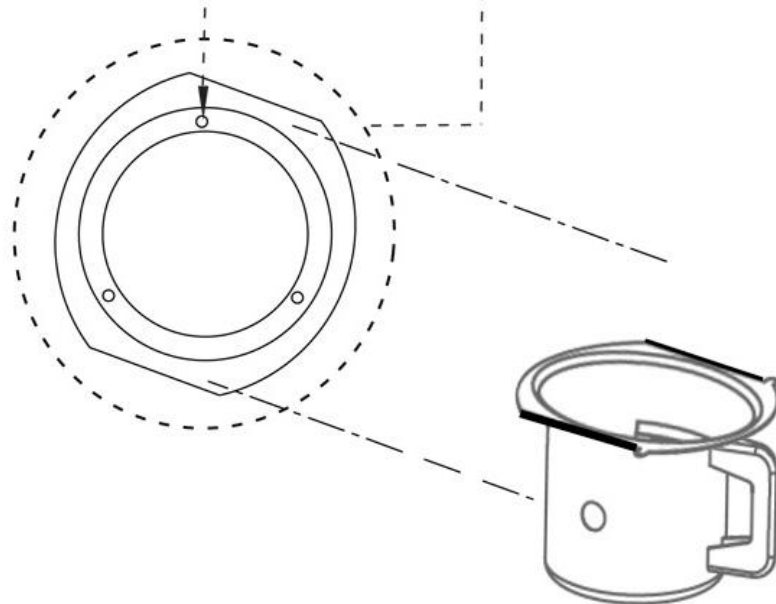

Assembly Instruction

Step 6

Insert two M5 x 12 Screw **A** into hole of Lid Hinge **12** and Bowl Hinge **13** as shown, and then using two M5 Lock Washer **O** and M5 Nut **L**. Tighten securely with Phillips head screwdriver.

M5 Nut must be tighten, But do not overtight in order to allow Grill Lid move freely.

Tigten all loose of the loose screws in Step 1 and 3

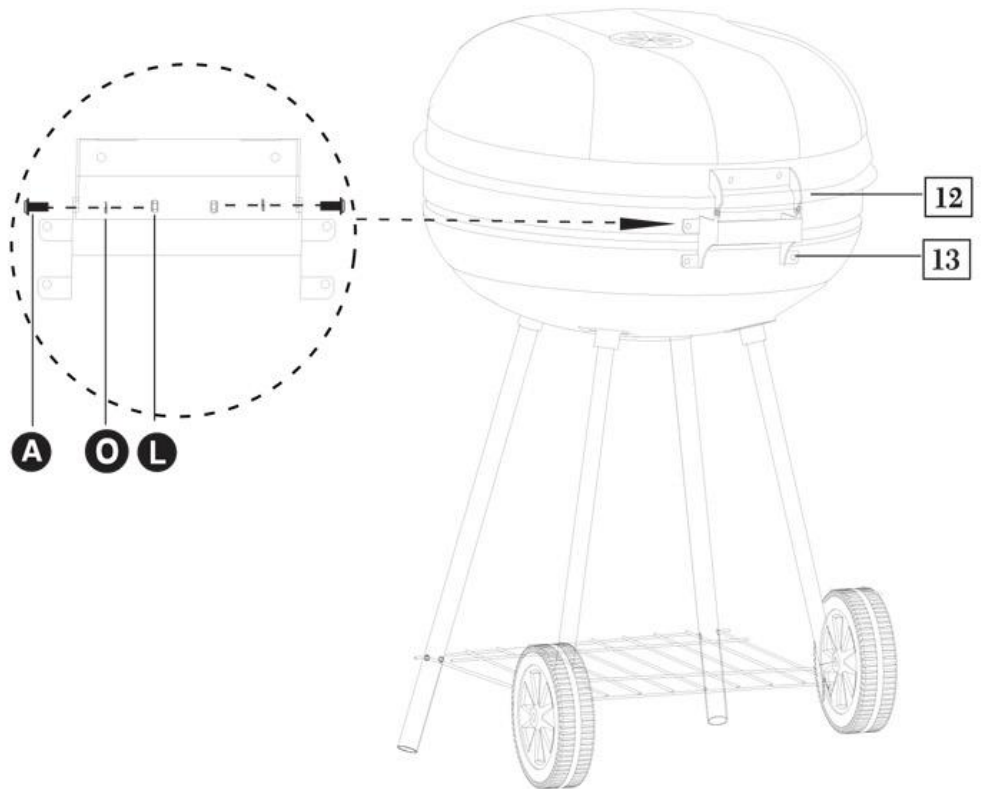

Step 7

Insert Warming Rack **14** into Grill Lid **1** and Grill Bowl **4** as shown. Insert assembled Ash Catcher **11** into slot of Ash Catcher Base **10** as shown.

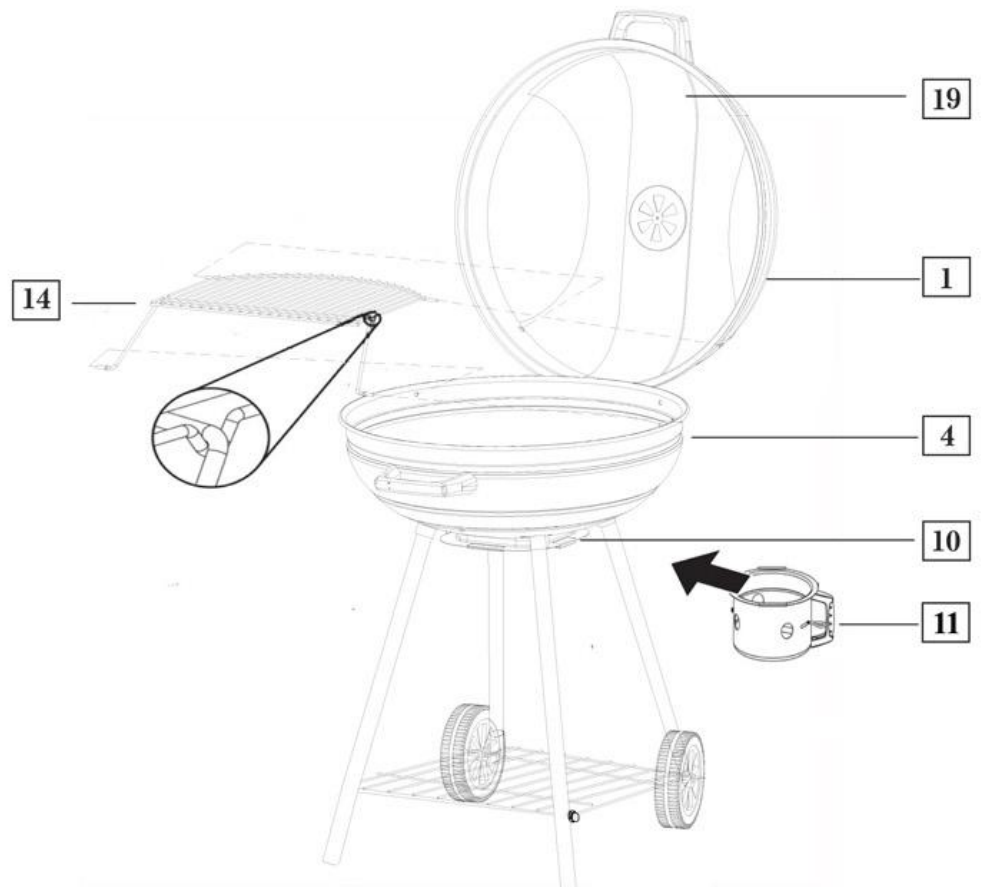

Assembly Instruction

Step 8

Insert Charcoal Window **18** ,
Charcoal Grid **17** and Cooking
Grid **15** into the Grill Bowl **4**
as shown. Using two Cooking
Grill Handle **16** to handle
Cooking Grill **15**

**ALWAYS WEAR OVEN
GLOVES
WHEN HANDLING THE
COOKING
GRID AND BARBECUE.**

Fully tighten all screws / Nuts;
but do not over tighten.

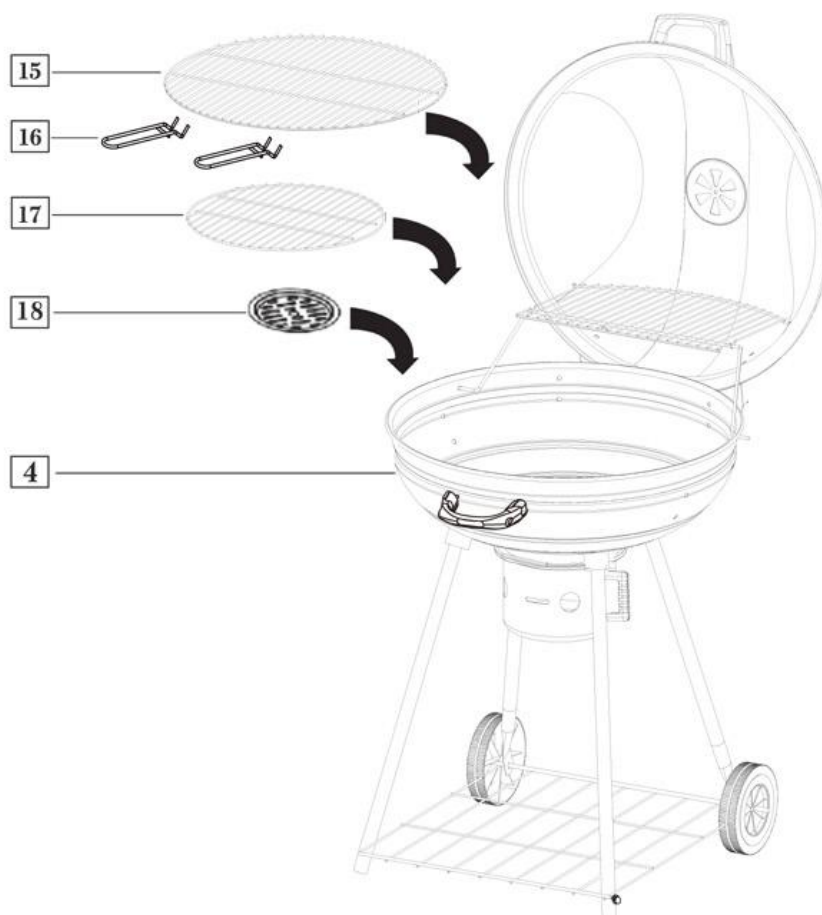

Assembly Instruction

Fully tighten all screws / Nuts;
but do not over tighten.

Assembly is complete.



If you need help or have damaged or missing parts, call the **Customer Helpline: 0345 6400800**