

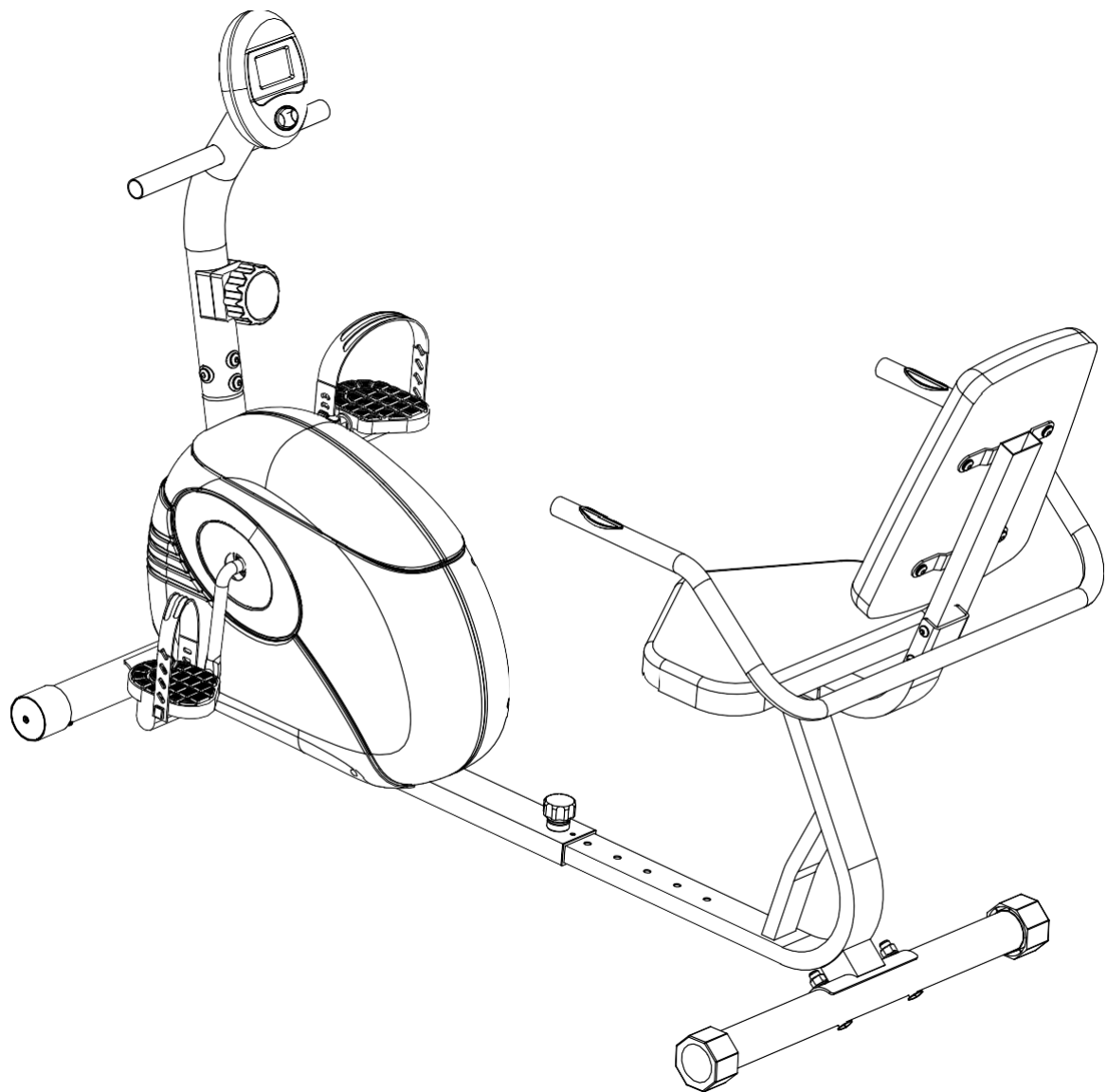

MARCY®

ME-709 RECUMBENT BIKE USER MANUAL

EN



Distributed By:
Pure-Tec Limited
www.puretecfitness.com

CONTENTS

| | |
|---|-------|
| Important Safety Information Weight Limit Capacities | 3 |
| Hardware Parts List | 4 |
| Pre Assembly Check List | 5 |
| Assembly Instructions | 6 - 9 |
| Computer Instructions | 10-11 |
| Exercise Instructions | 12-13 |
| Exploded Diagram | 14-15 |
| Parts List | 16-17 |
| Additional Information | 18 |
| Warranty Information | 19 |

IMPORTANT SAFETY INFORMATION









READ ALL INSTRUCTIONS BEFORE USING

THIS OWNER'S MANUAL CONTAINS ASSEMBLY, OPERATION, MAINTENANCE AND SAFETY INFORMATION. IN THE INTEREST OF SAFETY, PLEASE MAKE CERTAIN THAT YOU READ AND UNDERSTAND ALL THE INFORMATION BELOW.

1. This Bike is intended for class H (H=Domestic) use only. It is not designed for commercial use.
2. This machine has been tested to EN 957.
3. Read the OWNER'S OPERATION MANUAL and all accompanying literature and follow it carefully before using your Bike.
4. Keep children and pets away from the Bike at all times. Do not leave children unattended in the same room with the Bike. The Bike is not a toy and therefore parents and guardians should be aware of the natural tendency for children to play, leading to situations and behaviour for which the Bike is not intended.
5. If children are allowed to use the Bike their physical/mental development and above all, temperament should be taken into account. Constant supervision is therefore needed.
6. Position the Bike on a clear levelled surface which is clear of all obstacles as not to restrict movement whilst exercising. DO NOT use the Bike near water or outdoors.
7. Exercise equipment has moving parts. In the interest of safety, keep others, especially children, at a safe distance while exercising.
8. Never hold your breath while exercising. Breathing should remain at a normal rate in conjunction with the level of exercise being performed.
9. Rest adequately between workouts. Muscle tone develops during these rest periods. Beginners should work out twice a week and increase gradually to 4 to 5 times per week.
10. Remove all jewellery, including rings, chains and pins before commencing exercise.
11. Always wear suitable clothing and footwear during exercise. Do not wear loose fitting clothing that could become entangled with the moving parts of your exercise machine.

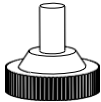
IMPORTANT!!! THE MAXIMUM RECOMMENDED WEIGHT CAPACITY FOR YOUR BIKE IS 110KGS.

HARDWARE PACKING LIST

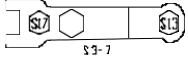
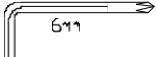
| No. | Description | Identifier | Q'ty |
|-----|----------------------------------|--|------|
| 8 | Allen screw M8*16 |  | 12 |
| 9 | Curved washer $\Phi 8 * \Phi 20$ |  | 8 |
| 13 | Carriage bolt M8*16 |  | 4 |
| 19 | Domed nut M8 |  | 4 |
| 20 | Leveling pad |  | 1 |
| 27 | Flat washer $\Phi 8 * \Phi 17$ |  | 12 |
| 31 | Screw M8*70 |  | 4 |
| 33 | Nylon nut M8 |  | 4 |
| | Box wrench |  | 1 |
| | Allen key L6 |  | 1 |

PRE-ASSEMBLY CHECK LIST

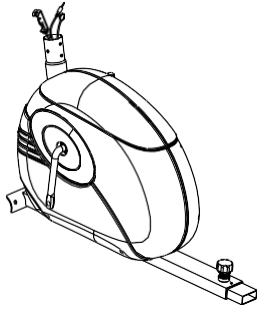

NO.1

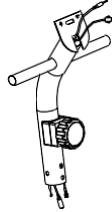

NO.4

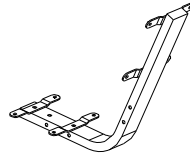

NO.25

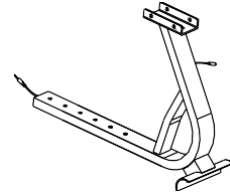

NO.26

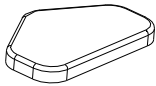

NO.32

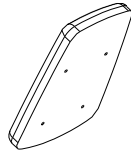

NO.28

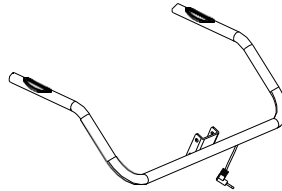

NO.22



NO.2

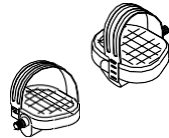

NO.17L/17R

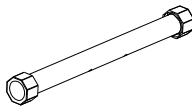

NO.30

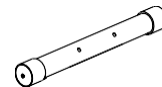

NO.14

| PART NO. | DESCRIPTION | Q'TY |
|----------|---|------|
| 1 | Main frame | 1 |
| 2 | Computer | 1 |
| 25 | Seat support tube | 1 |
| 26 | Sliding frame | 1 |
| 14 | Front Stabilizer w/Transportation Wheel | 1 |
| 30 | Rear Stabilizer w/Leveling End Cap | 1 |
| 4 | Front post | 1 |
| 17 | Pedal | 2 |
| 28 | Back Cushion | 1 |
| 32 | Seat Cushion | 1 |
| 22 | Handlebar | 1 |

ASSEMBLY INSTRUCTION

STEP 1

Attach the front stabilizer (14) to the main frame (1), securing with two allen screws (13), two curved washers (9) and two domed nuts (19).

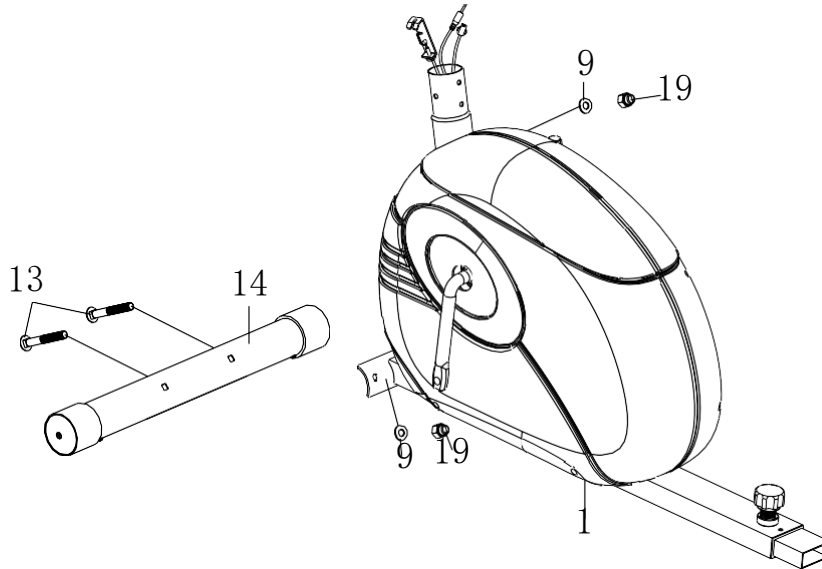

STEP 2

Connect middle extension hand pulse wire (63) with rear extension hand pulse wire (64). Attach support tube (26) to main frame (1), and tighten with quick release knob (24).

Thread leveling pad (20) into the main frame (1) from bottom.

Attach rear stabilizer (30) to the support tube (26) and tighten with 2 sets of carriage bolts (13), curved washers (9) and domed nuts (19).

Tip: Avoid pinching the Extension Wires

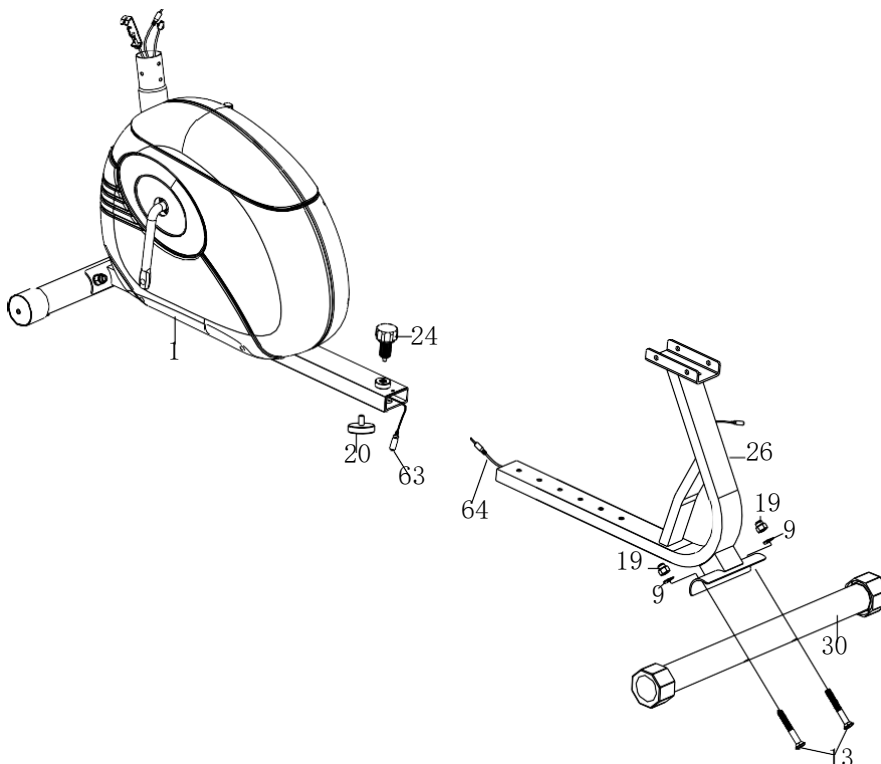

STEP 3

Connect the upper extension sensor wire (10) to the lower sensor wire (12).

Connect the front extension hand pulse wire (60) to the middle extension hand pulse wire (63).

Connect the tension control cable (7) to the extension tension cable (11).

Attach front post (4) to the main frame (1). Secure using four curved washers (9) and four allen screws (8).

Tip: Avoid pinching the Extension Wires and hand pulse wires

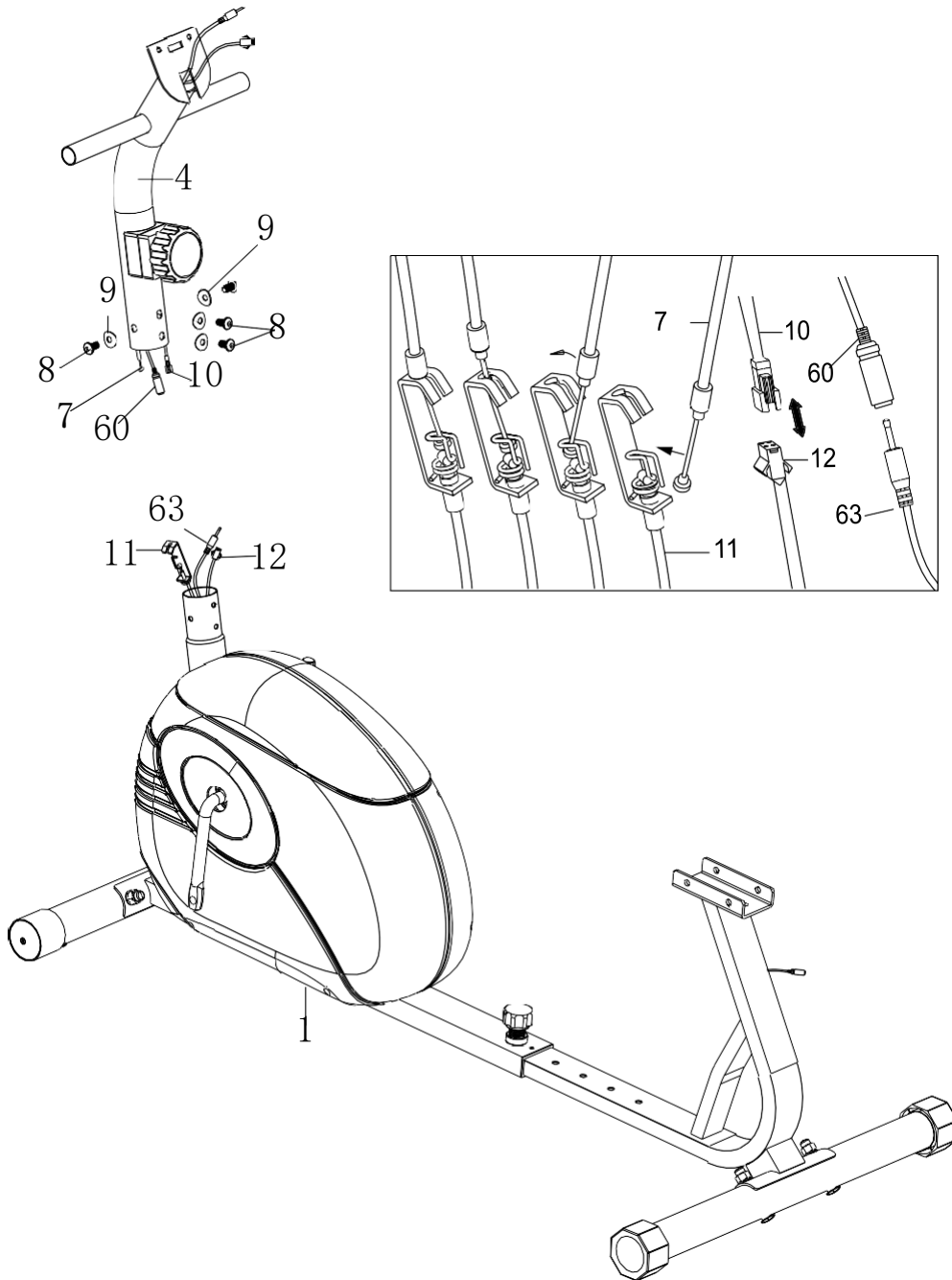

STEP 4

Attach seat support tube (25) to the sliding frame (26). Secure using two bolts (31), two flat washers (27) and two flange nuts (33)

Attach back cushion (28) to the seat support tube (25). Secure using four allen screws (8), and four flat washers (27).

Attach seat cushion (32) to the seat support tube (25). Secure using four allen screws (8), and four flat washers (27).

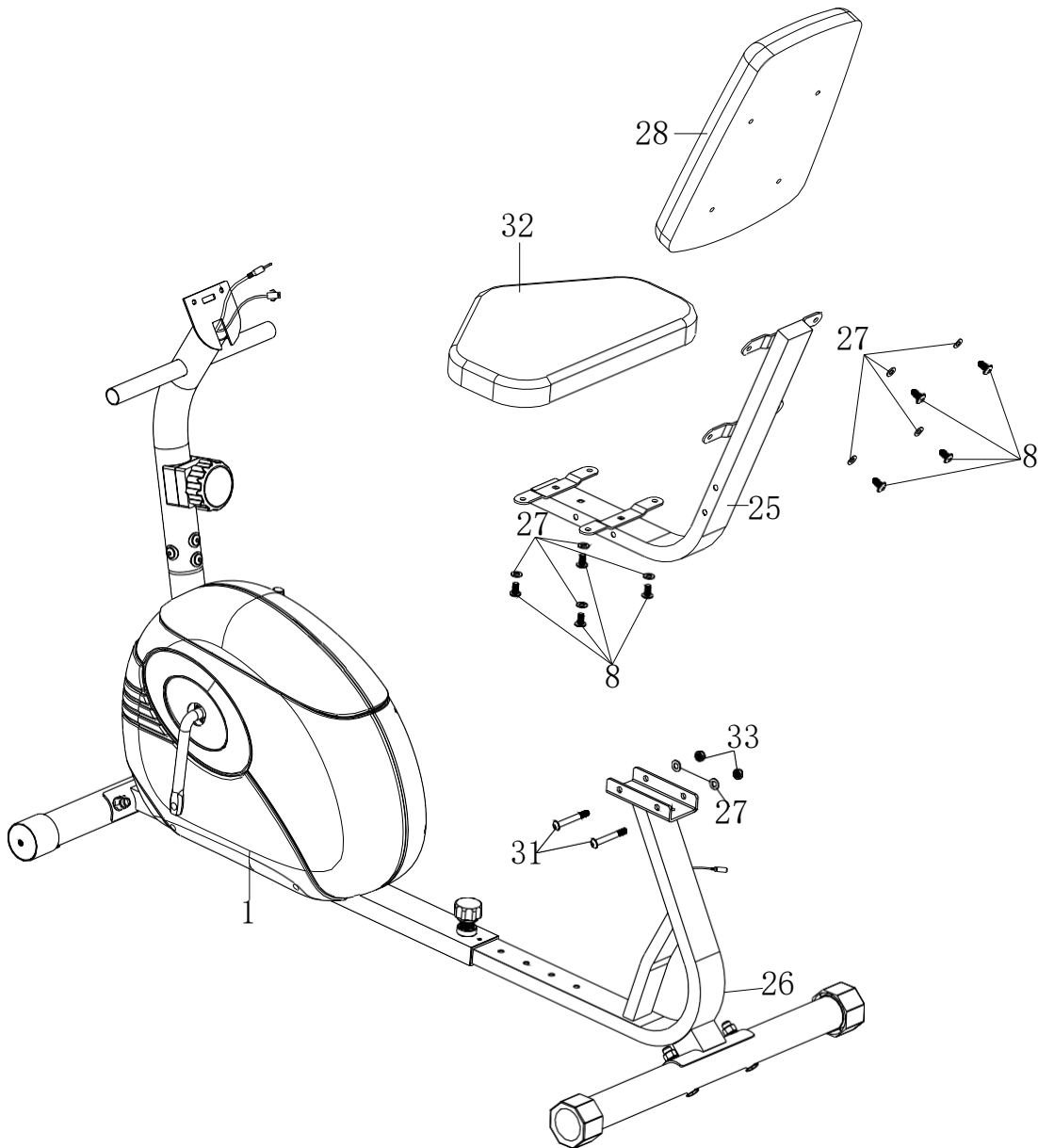

STEP 5

Attach rear handlebar (22) to the seat support tube (25). Secure using two bolts (31), two flat washers (27) and two nylon nuts (33).

Connect rear extension hand pulse wire (64) to the hand pulse wire (65).

Tip: Avoid pinching the pulse Wires

Connect the front extension hand pulse wire (60) to the pulse wire from the computer (02).

Connect the upper extension sensor wire (10) to the wire from the computer (02).

Tip: Avoid pinching the Extension Wires and pulse wires

Attach the computer (02) to the top bracket of front post (04). Secure using two screws (03) which are pre-assembled on the back of computer.

Thread the left pedal (17L) counterclockwise into the crank (21).

Thread the right pedal (17R) clockwise into the crank (21) on the other side.

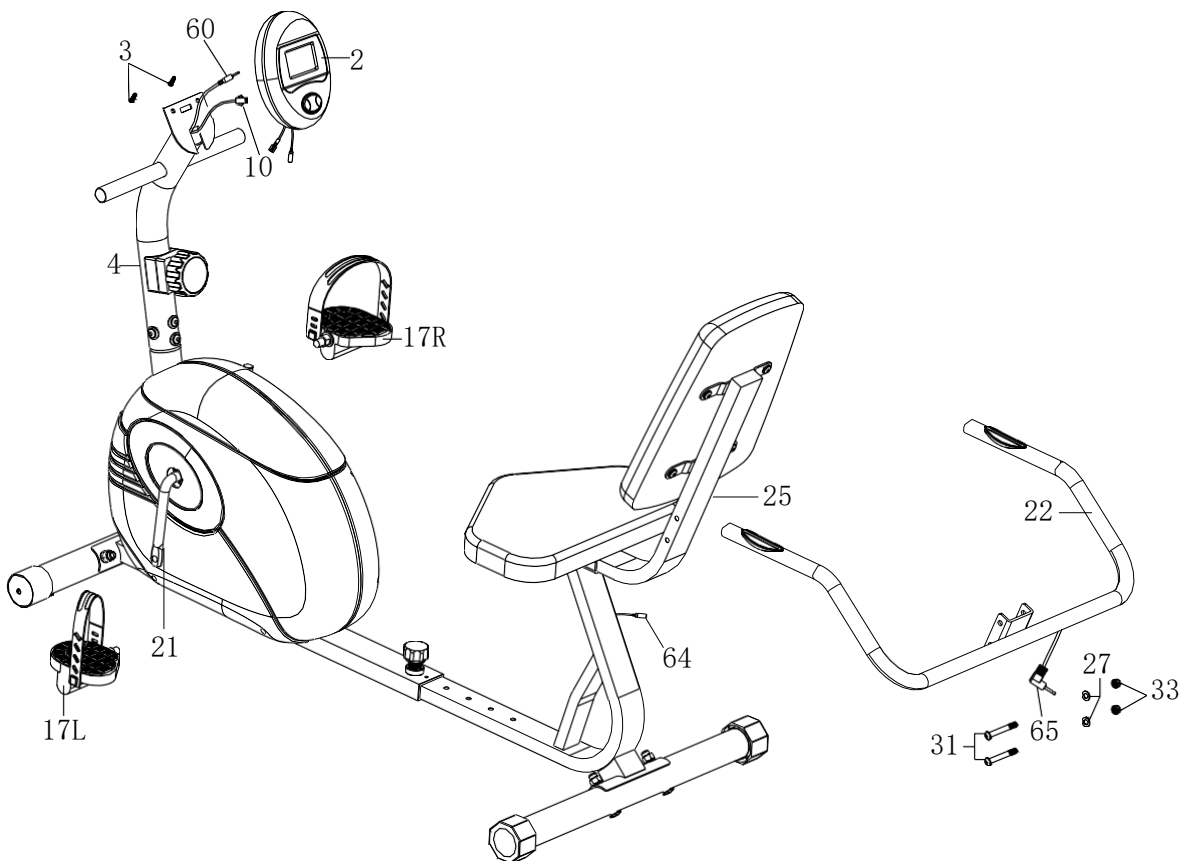

**CHECK ALL BOLTS AND NUTS ARE TIGHTENED
BEFORE USING THE MACHINE**

COMPUTER INSTRUCTIONS

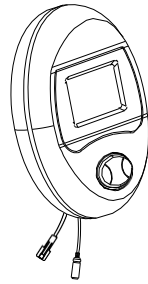

FUNCTIONAL BUTTONS:

MODE- Push down for selecting functions.

SET - To set the values of time、 distance and calories when not in scan mode.

RESET - Push down for resetting time、 distance and calories.

FUNCTION AND OPERATIONS:

- 1.SCAN:** Press “MODE” button until “SCAN” appears, monitor will rotate through all the 6 functions: Time、 speed、 distance 、 calories、 ODO and pulse. Each display will be hold 4 seconds.
- 2.TIME:** (1) Count the total time from exercise start to end.
(2) Press “MODE” button until “TIME” appears, press “SET” button to set exercise time. When the “set” is zero, the computer will alarm 15 seconds.
- 3.SPEED:** Display current speed.
- 4.DIST** (1) Count the distance from exercise start to end.
(2) Press “MODE” button until “DIST” appears. Press “SET” button to set exercise distance. When the “set” is zero, the computer will alarm 15 seconds.
- 5.CALORIES:** (1) Count the total calories from exercise start to end.
(2) Press “MODE” button unit “CAL” appears. Press “SET” button to set exercise calories. When the “set” is zero, the computer will alarm 15 seconds.
- 6. ODO:** Monitor will display the total accumulated distance.
- 7. PULSE RATE:** Press MODE button until “PULSE” appears. Before measuring your pulse rate, please place your palms of your hands on Both of your contact pads and the monitor will show your current heart beat rate in beats per minute(BPM) on the LCD after 6~7 seconds.
Remark: During the process of pulse measurement, because of the contact jamming, the measurement value may be higher than the virtual pulse rate during the first 2~3 seconds, then will return to normal level. The measurement value can not be regarded as the basis of medical treatment.
- 8.ALARM:** The computer will “Beep” when press “MODE”、 “SET” and “RESET” buttons.
- 9.AUTO ON/OFF & AUTO START/STOP**
Without any signal for 8 minutes, the power will turn off automatically. As long as the wheel is in motion or press any button, the monitor is in action.

SPECIFICATIONS:

| | | |
|-----------------------|-----------------------------|--|
| FUNCTION | Auto Scan | Every 4 seconds |
| | Running Time | 00:00 – 99:59 |
| | Current speed | The maximum signal can be picked up is 99.9 KM/H |
| | Trip Distance | 0.00~99.99 KM |
| | Calories | 0~999.9 Kcal |
| | ODO | 0.1~999.9KM |
| | Pulse Rate | 40~206BPM |
| Battery type | 2 pcs of size – AA or UM- 3 | |
| Operating temperature | 0°C~+40°C | |
| Storage temperature | - 10°C~+60°C | |

EXERCISE INSTRUCTIONS

Using your **RECUMBENT BIKE** will provide you with several benefits, it will improve your physical fitness, tone muscle and in conjunction with a calorie controlled diet help you lose weight.

1. The Warm Up Phase

This stage helps get the blood flowing around the body and the muscles working properly. It will also reduce the risk of cramp and muscle injury. It is advisable to do a few stretching exercises as shown below. Each stretch should be held for approximately 30 seconds, do not force or jerk your muscles into a stretch - if it hurts, STOP.

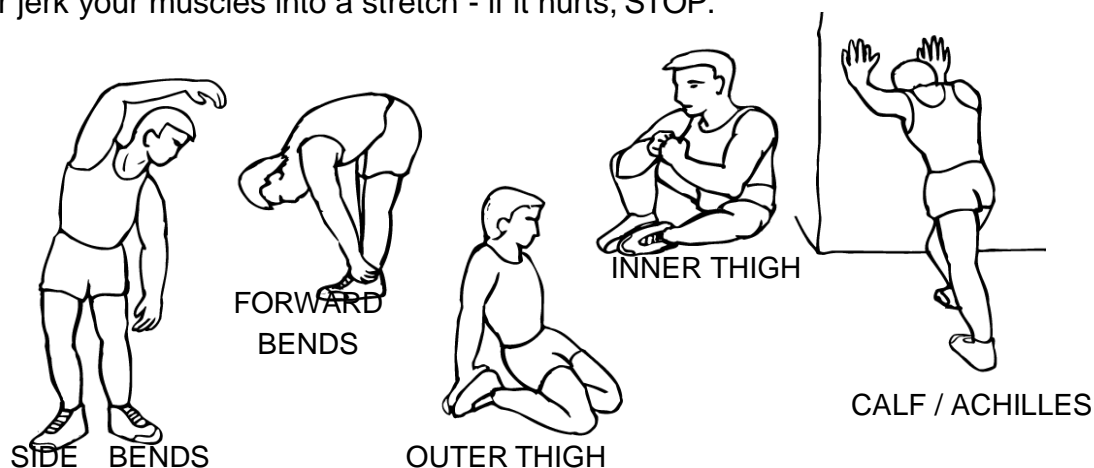

2. The Exercise Phase

This is the stage where you put the effort in. After regular use, the muscles in your legs will become more flexible. Work to your but it is very important to maintain a steady tempo throughout. The rate of work should be sufficient to raise your heart beat into the target zone shown on the graph below.

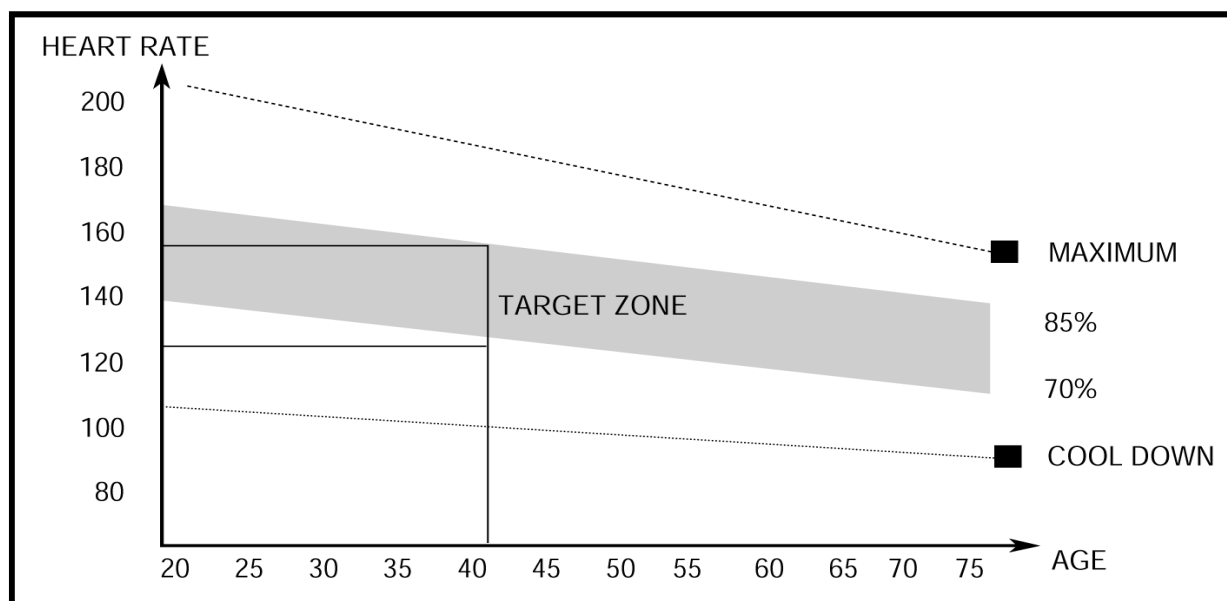

This stage should last for a minimum of 12 minutes though most people start at about 15-20 minutes

3. The Cool Down Phase

This stage is to let your Cardio-vascular System and muscles wind down. This is a repeat of the warm up exercise e.g. reduce your tempo, continue for approximately 5 minutes. The stretching exercises should now be repeated, again remembering not to force or jerk your muscles into the stretch.

As you get fitter you may need to train longer and harder. It is advisable to train at least three times a week, and if possible space your workouts evenly throughout the week.

MUSCLE TONING

To tone muscle while on your **RECUMBENT BIKE** you will need to have the resistance set quite high. This will put more strain on our leg muscles and may mean you cannot train for as long as you would like. If you are also trying to improve your fitness you need to alter your training program. You should train as normal during the warm up and cool down phases, but towards the end of the exercise phase you should increase resistance making your legs work harder. You will have to reduce your speed to keep your heart rate in the target zone.

WEIGHT LOSS

The important factor here is the amount of effort you put in. The harder and longer you work the more calories you will burn. Effectively this is the same as if you were training to improve your fitness, the difference is the goal.

EXPLODED DIAGRAM

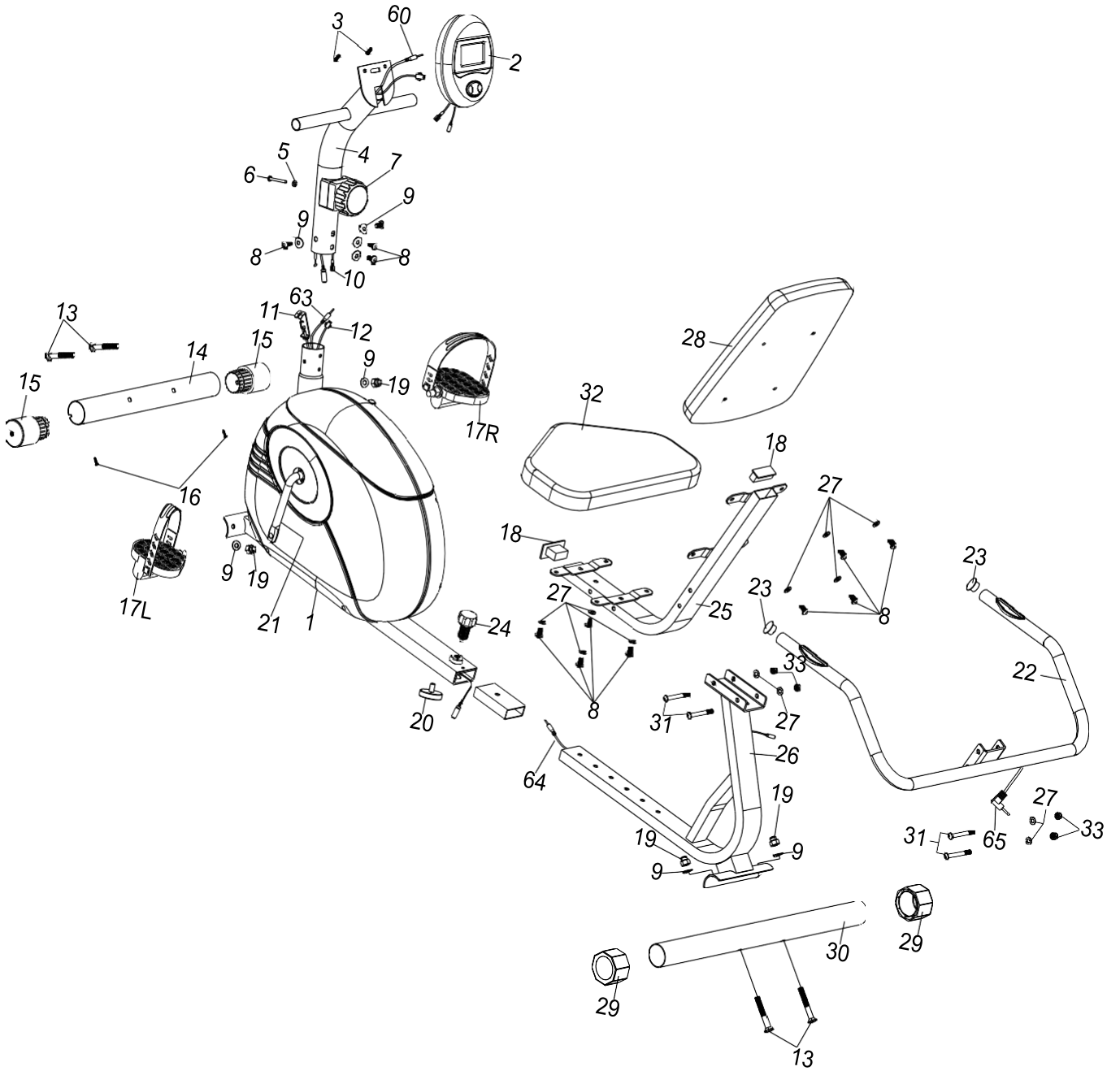

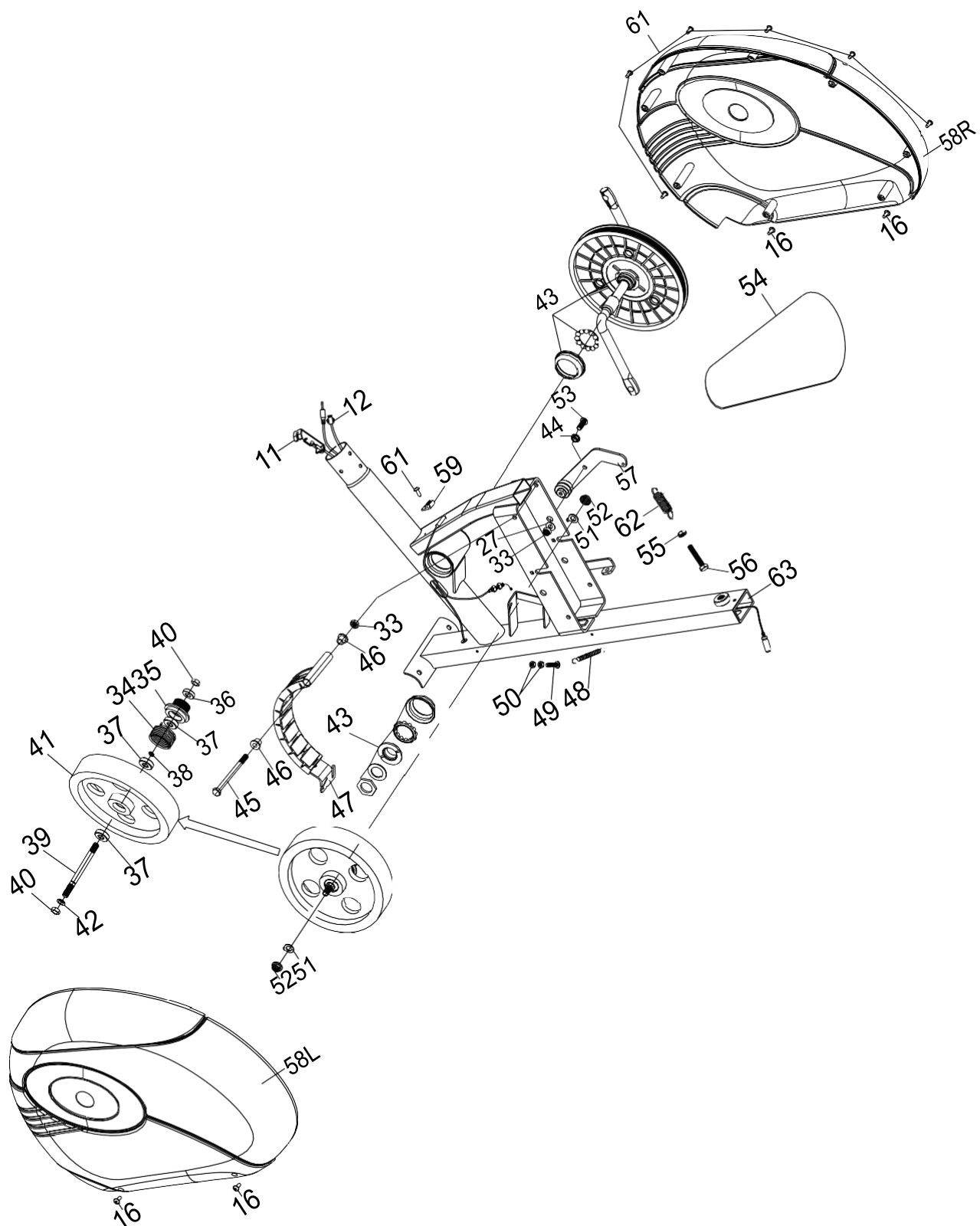

PART LIST

| Key No. | Description | Qty |
|---------|----------------------------------|-----|
| 1 | Main frame | 1 |
| 2 | Computer | 1 |
| 3 | Philips Screw M5*10 | 2 |
| 4 | Front Post | 1 |
| 5 | Washer $\Phi 5 * \Phi 12.7$ | 1 |
| 6 | Philips screw M5*40 | 1 |
| 7 | Tension control knob w/cable | 1 |
| 8 | Allen bolt M8*16 | 12 |
| 9 | Curved washer $\Phi 8 * \Phi 20$ | 8 |
| 10 | Upper computer sensor wire | 1 |
| 11 | Lower tension cable | 1 |
| 12 | Lower computer sensor wire | 1 |
| 13 | Carriage bolt M8*65 | 4 |
| 14 | Front stabilizer | 1 |
| 15 | End cap for front stabilizer | 2 |
| 16 | Philips screw ST5*16 | 6 |
| 17 | Pedal L/R | 1/1 |
| 18 | Square end cap | 2 |
| 19 | Domed nut M8 | 4 |
| 20 | Leveling pad | 1 |
| 21 | Crank | 1 |
| 22 | Handlebar | 1 |
| 23 | Handlebar end cap | 2 |
| 24 | Quick release knob | 1 |
| 25 | Seat support | 1 |
| 26 | Sliding frame | 1 |
| 27 | Washer $\Phi 8 * \Phi 17$ | 13 |
| 28 | Back cushion | 1 |
| 29 | End cap for rear stabilizer | 2 |
| 30 | Rear stabilizer | 1 |
| 31 | Hex bolt M8*70 | 4 |
| 32 | Seat cushion | 1 |
| 33 | Nylon nut M8 | 6 |
| 34 | Spring cultch | 1 |
| 35 | Little belt pulley | 1 |
| 36 | Bearing | 1 |
| 37 | Bearing | 3 |
| 38 | Copper washer | 1 |
| 39 | Axle for flywheel | 1 |
| 40 | Nut M10*1.25 | 2 |
| 41 | Flywheel | 1 |
| 42 | Bowl shaped spacer | 1 |

PART LIST

| Key No. | Description | Qty |
|---------|------------------------------|-----|
| 43 | BB parts | 1 |
| 44 | Spacer | 1 |
| 45 | Allen bolt M8*105 | 1 |
| 46 | Spacer for magnetic assembly | 2 |
| 47 | Magnetic assembly | 1 |
| 48 | Spring for magnetic assembly | 1 |
| 49 | Hex head screw M6*25 | 1 |
| 50 | Nut M6 | 2 |
| 51 | Washer | 2 |
| 52 | Flange nut | 2 |
| 53 | Allen screw M8*20 | 1 |
| 54 | Belt | 1 |
| 55 | Nut M8 | 1 |
| 56 | Hex head screw M8*45 | 1 |
| 57 | Idler assembly | 1 |
| 58 | Chain cover L/r | 1/1 |
| 59 | Sensor bracket | 1 |
| 60 | Front extension pulse wire | 1 |
| 61 | Self tapping screw ST5*15 | 7 |
| 62 | Spring for idler | 1 |
| 63 | Middle extension pulse wire | 1 |
| 64 | Rear extension pulse wire | 1 |
| 65 | Hand pulse wire | 1 |

ADDITIONAL INFORMATION



Packaging Disposal

Government guidelines ask that we reduce the amount of waste material disposed of in land fill sites. We therefore ask that you dispose of all packaging waste responsibly at public recycling centres.

End of Life Disposal



We at Pure-Tec Limited hope you have many years of enjoyable use from your Bike. However, a time will come when your Bike will come to the end of its useful life. Under '**European WEEE Legislation**' you are responsible for the appropriate disposal of your Bike to a recognised public collection facility.

CARE AND MAINTENANCE

1. Inspect and tighten all parts before using the Bike.
2. The Bike can be cleaned using a damp cloth and mild non-abrasive detergent. DO NOT use solvents.
3. Examine the Bike regularly for signs of damage or wear.
4. **Failure to examine the Bike regularly may affect the safety level of the equipment.**
5. Replace any defective components immediately and/or keep the Bike out of use until repair.

LIMITED WARRANTY

Pure-Tec warrants this product to be free from defects in workmanship and material, under normal use and service conditions. Please refer to www.puretecfitness.com for warranty terms. This warranty extends only to the original purchaser and is valid for home use only. Pure-Tec's obligation under this Warranty is limited to replacing damaged or faulty parts at Pure-Tec's option.

All returns must be pre-authorized by Pure-Tec. This warranty does not extend to any product or damage to a product caused by or attributable to freight damage, abuse, misuse, improper or abnormal usage, purchasers own repairs or for products used for commercial or rental purposes. No other warranty beyond that specifically set forth above is authorized by Pure-Tec.

Pure-Tec is not responsible or liable for indirect, special or consequential damages arising out of or in connection with the use or performance of the product or other damages with respect to any economic loss, loss of property, loss of revenues or profits, loss of enjoyments or use, costs of removal, installation or other consequential damages or whatsoever natures.

The warranty extended hereunder is in lieu of any and all other warranties and any implied warranties of merchantability or fitness for a particular purpose is limited in its scope and duration to the terms set forth herein.

Your statutory rights are not affected.

ORDERING REPLACEMENT PARTS

Replacement parts can be ordered by contacting our Customer Solutions Department, Monday to Friday, 8am – 5pm GMT :

Pure-Tec Limited
www.puretecfitness.com

Tel: +44 (0) 1482 212098
Email: service@puretecfitness.com

Monday - Friday 0800 - 1700GMT

When ordering replacement parts, please give the following information,

1. Model
2. Description of Parts
3. Part Number
4. Date of Purchase