

# cookworks

## Twin Professional Fryer

Model No. XJ-14301



## Care & Instruction Manual

For household and indoor use only


Please read these instructions before use and retain for future reference



## Electrical safety

- You should only plug the appliance into a 220V-240V AC, 50Hz supply. Connecting it to other power sources may damage the appliance and will invalidate the guarantee.
- Switch off and unplug when not in use and before cleaning the appliance.
- Keep the appliance and its cord out of reach of children less than 8 years.
- This appliance shall not be used by children from year 0 to 8 years. This appliance can be used by children aged from 8 years if they are continuously supervised. The appliance can be used by people with reduced physical, sensory or mental capabilities or lack of experience and knowledge if they have been given supervision or instruction concerning use of the appliance in a safe way and understand the hazards involved. Cleaning and user maintenance shall not be made by children.
- Keep control housing, cable, and plug dry and away from areas where it is likely to get splashed. Never immerse in water.
- Do not pull on the cable to disconnect from the mains supply.
- Do not operate the appliance if damaged or after it malfunctions. In the event the supply cord is damaged, in order to avoid a hazard it must only be replaced by a qualified service engineer, with a suitably approved part.
- This appliance must be positioned so that the plug is accessible and the plug socket is within easy reach of the power cord.
- This appliance must be plugged in to an earthed socket outlet.

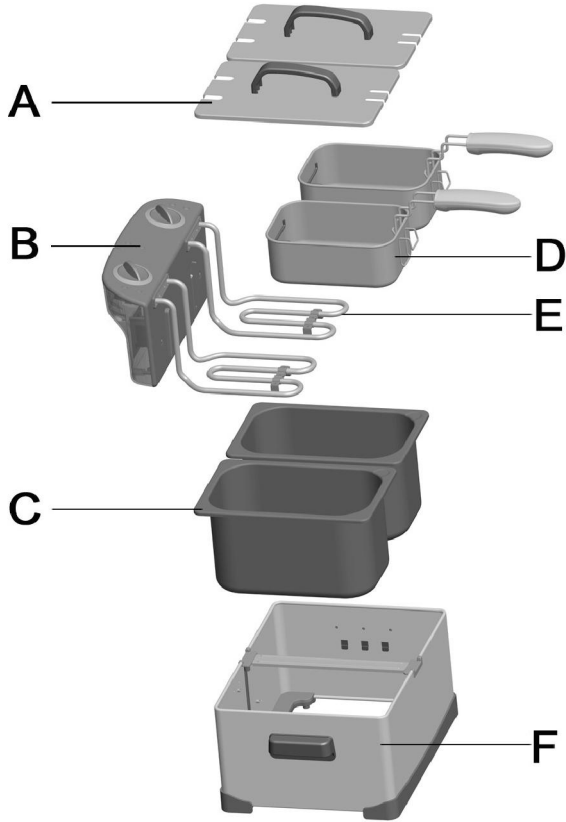
## Warning!

- This appliance is intended exclusively for use in domestic households. It is not suitable for commercial use.
- Do not operate this appliance with the storage lids fitted.
- Cooking appliances should be positioned in a stable situation with handles positioned to avoid spillage of hot liquids.
- Never leave the fryer unattended during use or move the fryer when the oil is hot.
-  The surfaces of the fryer are liable to become hot during and immediately after use; wear oven gloves when handling the appliance and use long handled utensils when checking the food. Note the fryer and heating elements are subject to residual heat after use.
- Do not use the fryer on, near or under surfaces that are heat sensitive or those that may be damaged by steam.
- Do not fill the oil tanks above maximum level marked or below the minimum level. Check the oil level before each use.
- Do not over fill the frying baskets. Take care not to fill beyond  $\frac{2}{3}$  full for most foods and a maximum of 600g of chips.
- Do not fit the lids when the fryer is in operation
- Do not reach over the appliance while it is in operation.
- Only use with the parts provided and to heat cooking oil. This appliance can cause personal injury if misused.
- Do not operate the fryer using a timer or separate remote control.
- Do not mix different types of oil and never use solid fats.
- Do not cover and allow the fryer to cool completely before storing.
- In the unlikely event that a fat fire occurs, close the lid. Unplug the fryer and smother the flames with a damp cloth.

## Food safety

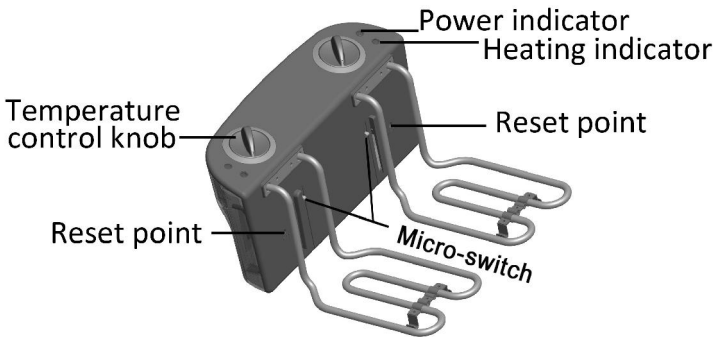
- Thoroughly defrost frozen meat, poultry, fish and seafood in the refrigerator before cooking unless cooking from frozen advice is provided by the food packaging.
- Keep raw meat and poultry separate from cooked foods.
- Always wash hands after handling raw meat and poultry, before handling any ready to eat foods.
- Wipe and disinfect surfaces that have been in contact with raw meat and poultry.
- Use separate utensils for handling raw meat/poultry and cooked food or wash them thoroughly between use.
- To check whether meat, particularly poultry, is cooked, pierce the flesh with a skewer or fork; the juices should run clear. Ensure the product is piping hot throughout.
- Fish is cooked when it appears opaque and can be flaked easily.

# Parts

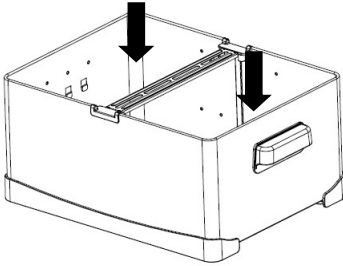
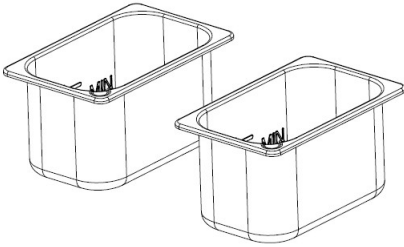


- A. Storage lids
- B. Control housing
- C. Oil tanks

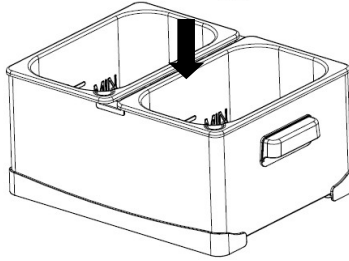
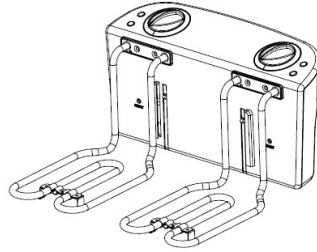
- D. Frying baskets
- E. Heating elements
- F. Outer casing



## Assembly

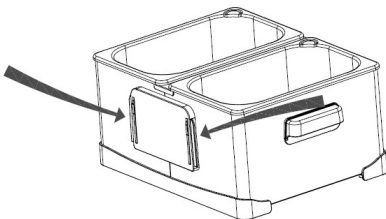
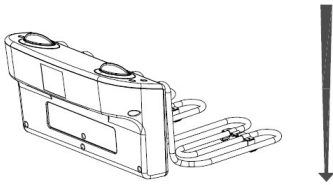


**Fig. 1**

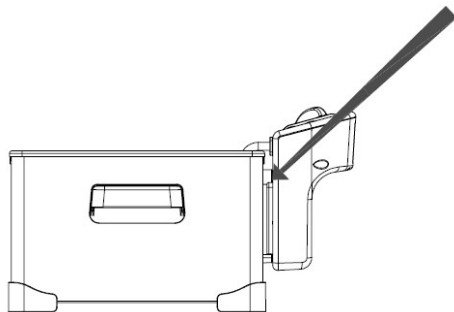


**Fig. 2**

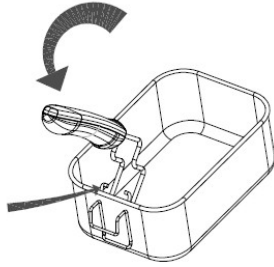
1. Place the fryer on a stable, flat, heat resistant surface, away from flammable materials and surfaces that may be damaged by steam. Check that the plug will reach a socket and that it can be accessed without reaching over the fryer.
2. Fit the oil tanks into the outer casing (fig. 1).
3. Fit the heating elements into the oil tanks ensuring that the control panel is correctly engaged into the brackets (figs.2 & 3). If the control panel is not correct fitted, the micro switches will prevent the fryer from working (fig. 4).



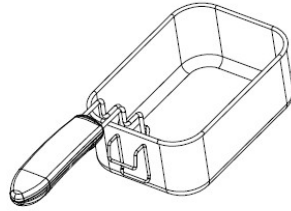
**Fig. 3**



**Fig. 4**

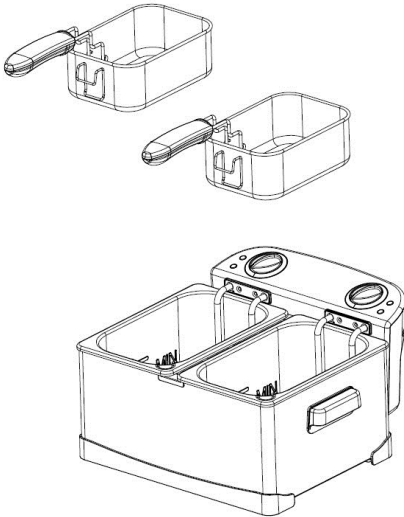


**Fig. 5**

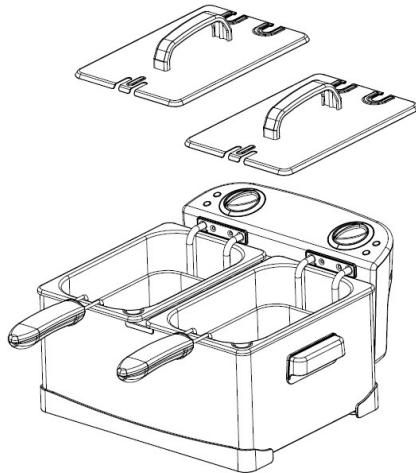


**Fig. 6**

4. Lift the handle of the frying basket backward (figs. 5 & 6) until it clicks in to position with the wire handle sitting either side of the wire bracket.
5. Fit the baskets into the oil tanks (fig.7).
6. **For storage** fit the lids, the smaller pair of grooves should be towards the front (fig. 8) and when correctly fitted the lid will be flush with the edge of the oil tank.



**Fig. 7**



**Fig. 8**

## **Before first use**

1. Clean all detachable parts in accordance with the cleaning section of these instructions.
2. Become familiar with -
  - The parts of the fryer – See page 5
  - How to fit and fold the frying basket handle – See figs. 5 & 6
  - The drainage position for the frying baskets - See fig. 9
  - How to remove and refit the lids – See fig. 8
  - How to fit and remove the oil tanks – fig. 1.
  - How to fit the control housing to the outer casing – figs 2 - 4.

## **To use**

1. Clean thoroughly before use.
2. Place the assembled fryer on a stable, flat, heat resistant surface, away from flammable materials and surfaces that may be damaged by steam. Check that the plug will reach a socket and that it can be accessed without reaching over the fryer.
3. Fill the tanks with cooking oil to the required level marked inside the oil tank. Do not fill past the maximum (2.5 litre) or below the minimum (2 litre) level.
4. Do not fit the lids.
5. Check that the temperature controls are both at the 'OFF' position. Fully unwind the cable, plug in and switch on, the power indicator will illuminate. For your safety do not allow the cable to dangle over the edge of units.
6. Rotate each temperature control knob, set them to the required cooking temperature and the heating indicators will now illuminate. Each heating element works independently.
7. Allow the oil to preheat (8-12 minutes approx.). When the oil has reached the required cooking temperature the heating indicator will extinguish.
8. Place the food to be cooked into the frying baskets taking care not to fill beyond  $\frac{2}{3}$  full for most foods and a maximum of 600g of chips.
9. Place the baskets slowly into the fryers.

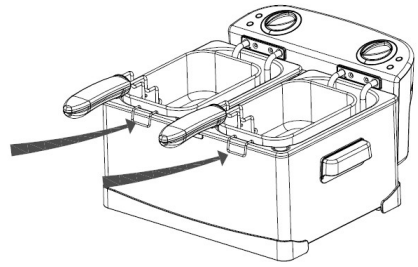


10. When frying is complete, lift each frying basket and hook the baskets onto the end of the oil tanks to permit the oil to drain back into the oil tanks for a short while.

11. If the food requires further cooking, place the basket and food back into the oil.

12. When cooking has been completed, move the temperature control knob back to the 'OFF' position, the power light will extinguish and switch the fryer off at the mains. The lids may now be fitted

13. Allow the oil to cool fully (at least 3 hours) before emptying and cleaning the fryer.



**Fig. 9**

## **Tips for successful frying**

- Choose oil that can withstand high temperatures. Do not use solid fats.
- Do not mix different types of oils.
- Change the oil regularly (8-12 uses) or when it discolours. Some cooking oils (e.g. sunflower oils) need to be changed more frequently.
- Dry food thoroughly before frying and remove any ice from frozen foods to prevent oil overflowing and to extend the life of the oil.
- Rinse raw starchy foods (e.g. potatoes) with water and pat dry to help prevent them from sticking together.
- Do not over fill the frying basket and separate food where possible. Take care not to fill the basket beyond  $\frac{2}{3}$  full for most foods and a maximum of 600g of fresh chips per basket.
- After frying do not leave the food draining in the frying basket for too long as the steam will soften any coatings.
- Raw foods usually require frying at a lower temperature than cooked or partially cooked foods.
- Smaller quantities of food will cook faster than larger quantities.
- The cooking time will vary according to the shape, thickness and composition of the food.
- Smaller pieces will cook quicker than larger pieces. For best results, ensure pieces of food are similar in size.
- Arrange the food with spaces between the pieces to allow even frying.
- Cook foods with a lighter flavour before those with stronger flavours to help prevent flavour taint.

## **Frying chart**

- All the times stated in the table are a guide only - always check that the centre of the food is piping hot.
- The times will vary according to personal choice, the type of oil used size or thickness of food being cooked (e.g. one large piece will take longer to cook than several smaller pieces of an equivalent weight).
- Always check food packaging for suitability for frying and use any recommended cooking times and temperatures stated on the packaging.

## Frying chart (continued)

Food	Quantity	Frying temp. (°C)	Time (min)
<b>Fresh foods</b>			
French fries / Chips*	600g *	160*	7 – 11
Potato croquettes	4 - 5 pieces	170	3 – 4
Mushrooms (button)	Single layer	170	4 – 5
Aubergine slices	350g	190	3 – 4
Breaded fish fillets (e.g. plaice, sole)	3 pieces / 215g	160	5 – 7
Camembert wedges (breaded)	3 – 4 pieces	190	2 – 3
Prawns (raw)	8 – 10 pieces	180	3 - 4
Chicken nuggets	8-10 pieces	180	3 – 4
<b>Frozen food</b>			
Chips	450g	175	4 - 8
Potato croquettes	6 - 8 pieces	190	5 - 6
Mushrooms (breaded whole)	10 pieces	190	4 – 5
Fried onion rings	6 – 8 pieces	190	3 – 4
Breaded scampi	16 pieces / 250g	180	4 – 5
Fish fillets (e.g. cod, haddock)	3 fillets	190	8 - 10
Fish fingers	8 pieces	190	4 – 5
Chicken nuggets	8 – 10 pieces	190	3 – 5

- If cooking thicker chips or larger quantities of fresh chips, partially cook the chips in small batches ahead of the required time. Cook chips at 150 °C until soft to the feel and light golden colour and then remove the chips from the fryer (place on a plate lined with kitchen towel) and allow to cool. When the chips are required, heat the oil to 190°C and fry until crisp and a mid golden colour. Each batch will take about a minute until crisp and allows batches of chips to be ready to eat in a short time.

## Cleaning

1. Switch off and unplug the fryer and allow it and the oil to cool completely.
2. Remove the frying basket.
3. Carefully lift out the oil tanks and pour the **cold** cooking oil into a storage container. It is not recommended that the oil is stored in the fryer between uses.
4. Wash the outer casing, frying baskets, lids, and oil tanks in hot water with a little washing up liquid. Rinse and dry thoroughly. Do not use detergent or abrasives as these may scratch the surface. Not suitable for the dishwasher.
5. Wipe the control housing and elements with a soft damp cloth soaked in soapy water. Rinse and dry surfaces with a soft dry cloth. Do not use detergent or abrasives as these may scratch the surface. **Never immerse the control housing in water.**
6. After cleaning reassemble the fryer and fit the lids for storage.

## Technical specification

Rated voltage	220-240V AC 50Hz
Power consumption	2400W
Class rating	I (Earthed)
BS 1362 fuse	13A
Capacity	2 x 2.5 litre



## Plug / Wiring advice

The wires in this mains lead are coloured in accordance with the following UK electrical code:

BLUE = NEUTRAL

BROWN = LIVE

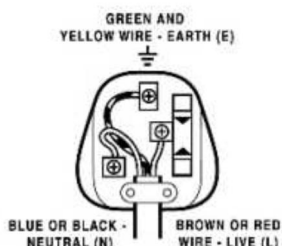
GREEN + YELLOW = EARTH

### Non-rewireable plug

This appliance may be fitted with a “non-rewireable” plug. If you need to change the fuse in a “non-rewireable” plug, the fuse cover must be refitted. If the fuse cover is lost or damaged, the appliance must not be used.

### Rewireable plug

The colours of the wires in the mains lead of this appliance may not correspond with the coloured markings identifying the terminals in a rewireable plug. **Rewireable plugs should only be replaced by a suitably competent person. If in doubt, consult a qualified electrician.**



The BLUE wire must be connected to the terminal marked with the letter N

The BROWN wire must be connected to the terminal marked with the letter L

The GREEN & YELLOW wire must be connecting to the terminal marked with the letter E or the earth symbol (⏏).

## Recycling electrical products



This marking indicates that this product should not be disposed with other household wastes throughout the EU. To prevent possible harm to the environment or human health from uncontrolled waste disposal, recycle it responsibly to promote the sustainable reuse of material resources. To return your used device, please use the return and collection systems or contact the retailer where the product was purchased. They can take this product for environmental safe recycling.

If you encounter any problems with this product please call our customer care team on 0345 640 30 30

Produced in China for Argos Limited, 489 – 499 Avebury Boulevard Central Milton Keynes MK9 2NW. UK.



## PRODUCT GUARANTEE

This product is guaranteed against manufacturing defects for a period of



Year

This product is guaranteed for twelve months from the date of original purchase.

Any defect that arises due to faulty materials or workmanship will either be replaced, refunded or repaired free of charge where possible during this period by the dealer from whom you purchased the unit.

The guarantee is subject to the following provisions:

- The guarantee does not cover accidental damage, misuse, cabinet parts, knobs or consumable items.
- The product must be correctly installed and operated in accordance with the instructions contained in this manual. A replacement copy of this instruction manual can be obtained from [www.argos-support.co.uk](http://www.argos-support.co.uk)
- It must be used solely for domestic purpose.
- The guarantee will be rendered invalid if the product is re-sold or has been damaged by inexpert repair.
- Specifications are subject to change without notice.
- The manufacturer disclaims any liability for the incidental or consequential damages.
- The guarantee is in addition to, and does not diminish your statutory or legal rights.

Guarantor: Argos Ltd  
489 - 499 Avebury Boulevard  
Central Milton Keynes  
MK9 2NW  
[www.argos-support.co.uk](http://www.argos-support.co.uk)