

iWalk™

The Family Treadmill

iWalk™

The Family Treadmill

Thank you for purchasing iWalk™ The Family Treadmill from JML. To get the best results from this treadmill, please read these instructions in full and keep them safe for future reference.

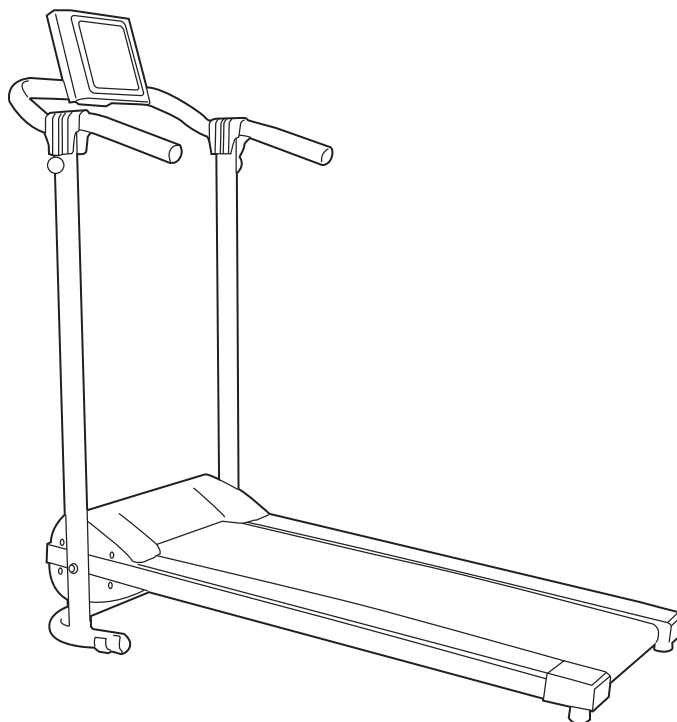

Contents

Safety Warnings & Advice _____	2	Manual Program _____	10
Your iWalk _____	4	Pre-set Program _____	10
Before use _____	5	After use _____	11
Assemble your iWalk _____	6	Cleaning & Care _____	12
Using your iWalk _____	7	Guarantee _____	13
Operating instructions _____	7	Technical Information _____	14
Your Control Panel _____	7	Technical specifications _____	14
Warm-up & Preparation _____	9		



Safety Warnings & Advice

Be sure to read the entire manual, warning labels and emergency stop procedure before assembly and operation of the iWalk.

Provide attention to the following safety precautions:

To ensure that iWalk is used safely and properly, all users must read this manual.

Before starting any exercise program, consult your physician.

If you experience dizziness, nausea, chest pain or other abnormal symptoms while using this treadmill, stop exercising immediately and consult your doctor.

Persons weighing over 110 kg should not use iWalk.

Only one person at a time should use iWalk.

Highly recommend stretching before and after use.

Ensure you are hydrated before, during and after use.

Always keep children and pets away. This product is not a toy.

Inspect the iWalk before exercising to ensure that all nuts and bolts are fully tightened.

Ensure that nothing interferes with the running area during exercise.

Keep hands and feet away from all moving parts.

Do not insert any object into any openings.

Only switch on and use the iWalk on an uncluttered, flat surface.

DO NOT use on thick carpets or rugs. This could prevent air circulation to cool the motor/engine.

ONLY assemble and use in a room with sufficient space.

For household use only.

Wear correct exercise clothing. DO NOT wear loose clothing while using the iWalk. Keep long hair tied back.

Safety Warnings & Advice

DO NOT start at a high speed. Start at a low, comfortable speed to begin your workout.

DO NOT stand on the running belt when beginning the exercise. Ensure you are standing on the side frames, which are on both sides of the running belt.

Use caution when getting on or off the iWalk.

DO NOT use the iWalk if you have a pacemaker or other cardiac device.

If pregnant, please consult your doctor before using the iWalk.

DO NOT use when ANY parts of this product are damaged.

Replace damaged parts immediately with replacement parts from JML and only use when repaired by a qualified technician.

Turn off the switch and unplug the power cord when the iWalk is not in use.

Keep power cord away from heated surfaces.

Store in a clean and dry place.

ONLY service from a qualified technician.

Run as close as possible to the centre of the belt for safety in the direction of the control panel.

DO NOT attempt to run backwards.

DO NOT step or jump off the running belt while the iWalk is moving. Slow down and turn off first to ensure a safe dismount.

When unfolding to use, carefully open and rotate the back of the running belt towards the ground as it is heavy.

Ensure the the iWalk is unplugged when lubricating the belt.

Only use the iWalk for its intended use as described in this manual.

The clip of the Magnetic Safety Key must be attached to the magnetic part of the control panel, otherwise the iWalk

Your iWalk™ The Family Treadmill

won't start. Attach the other end to the user at waist level before use. Failure to do so is very dangerous. For safety reasons, if the iWalk belt is moving and the Magnetic Safety Key is removed from the Control Panel, the iWalk belt will stop immediately.

Plug your audio jack into your phone and the iWalk prior to turning on the iWalk.

Plugging the audio jack into the iWalk while on, there will be an audible 'fuzz' noise that may be high pitched. To avoid this, plug your audio jack into your phone and the iWalk prior to turning on the iWalk.

Please store safely away from children to prevent a falling / toppling hazard.

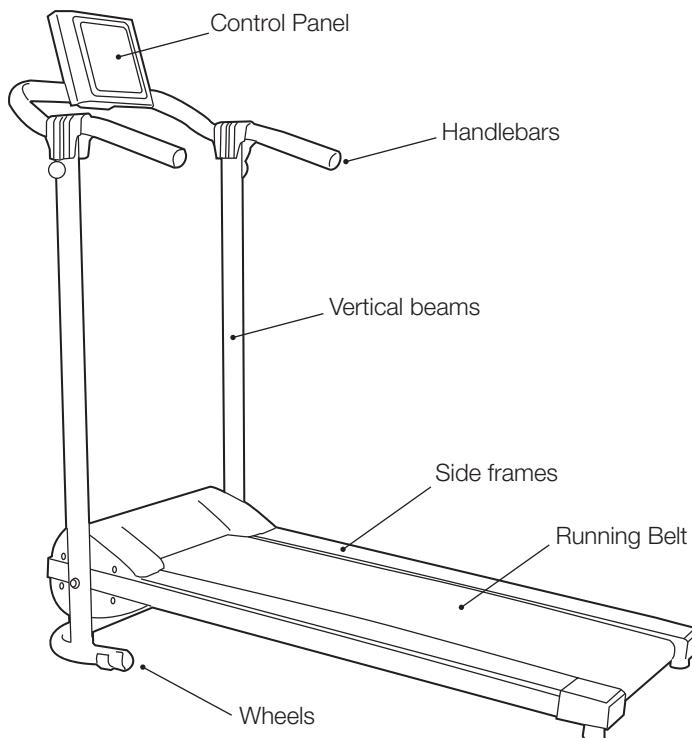

Your iWalk™ The Family Treadmill

Before Use

As the iWalk is extremely heavy, carefully unpack from its packaging to avoid damaging the unit or injuring yourself. Ensure the area is clear and has a flat surface.

Your iWalk is nearly ready-to-go out of the box. There are only a few things to assemble before you use. Ensure that you are in a clear area and remove all packaging before using.

A - Folding pin - 1x

B - Vertical beams locking bolt - 1x

C - M8 Screws with washers – 4x

D - Plastic covers – 2x

E - Control panel locking pin – 1x

F - Magnetic safety key - 1x

G - 3.5mm Audio cable - 1x

H - Allen key - 1x

I - Oil lubricant bottle - 1x

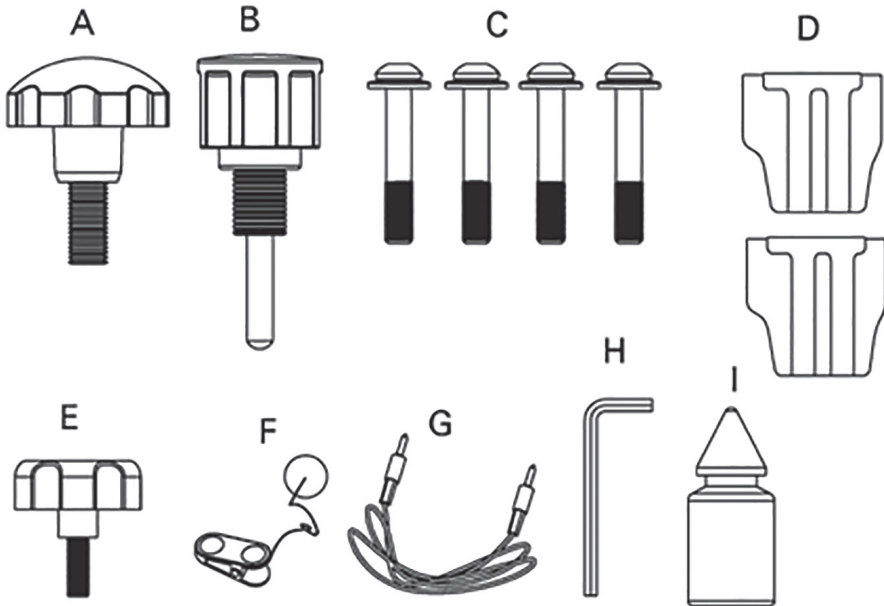

Your iWalk™ The Family Treadmill

Assemble Your iWalk™ The Family Treadmill

1. Lift the beams up vertically, inserting the Vertical beams locking bolt (B), turning clockwise to tighten.
2. Place the Folding Pin (A) in the left Vertical beam. This pin will be used to secure when folding to store.
3. Place the Handlebars over the 2 Vertical beams and tighten in the M8 screws with washers x4 (C) (x2 on either side) using the Allen Key provided. Then place the Plastic Covers (D) over this.
4. Secure the Control Panel in place to the front of the Handlebars using the Control Panel Locking Pin (E).
5. Place the Magnetic Safety Key (F) to the Control Panel.
6. If you want to use the inbuilt speakers, connect one end of the 500mm long 3.5mm male-to-male audio cable (G) to the Control Panel and the other end into your media player.

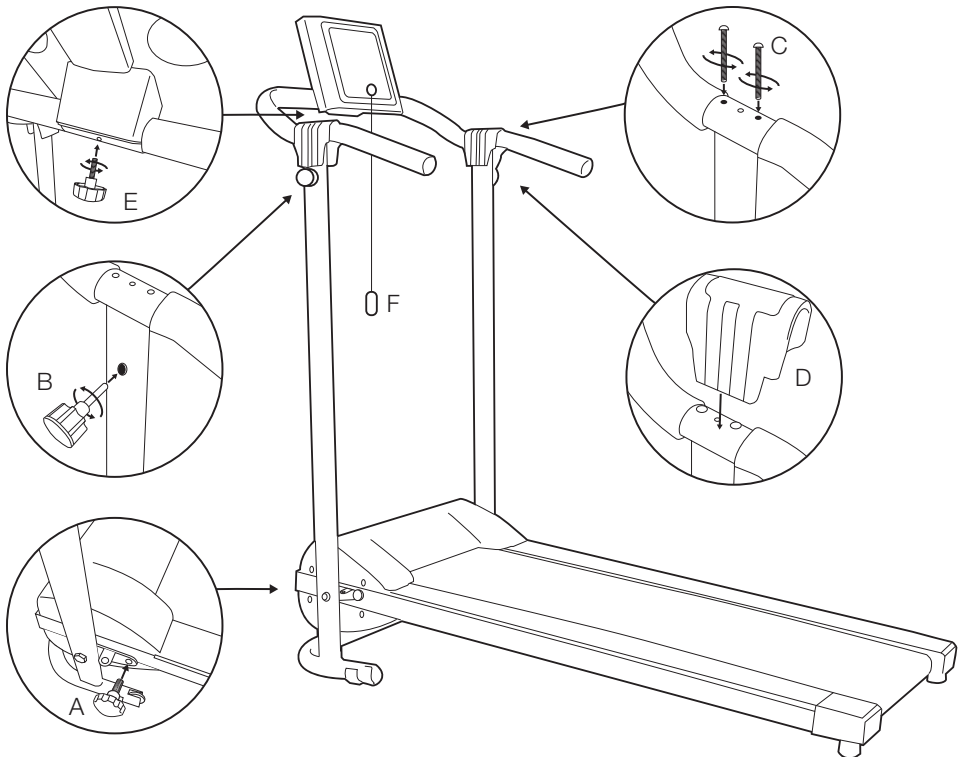

Using your iWalk™ The Family Treadmill

Operating Instructions

IMPORTANT: Ensure the unit is placed on a flat, stable surface before using. If the equipment is not functioning properly, do not use and contact the distributor.

1. Connect the plug to the power outlet.
2. Switch on the button at the base of the iWalk. This will illuminate to indicate that

the unit has power and the control panel will light up.

3. The clip of the Magnetic Safety Key must be attached to the user at waist level and magnetically attached to the control panel before use. Failure to do so is very dangerous.
4. Your iWalk is now ready to use.

Your Control Panel



Using your iWalk™ The Family Treadmill

The dashboard of your Control Panel is designed with a selection of features to enhance your workout.



On/Off: To turn the treadmill on or off.



Mode: (While stationary) To select programme and timer. (while running) Displays speed, time, distance and calories.



Speed +/-: To adjust speed up or down. The speed range is 1kmph – 10kmph.



Explorer: Shows how much time has elapsed, distance covered, and calories burnt.



LED Speed Indicator: Press to view current speed. LED light illuminates.



LED Time Indicator: Press to view current time. LED light illuminates.



LED Distance Indicator: Press to view current distance. LED light illuminates.



LED Calorie Indicator: Press to view current calories burnt. LED light illuminates.



Audio: Input your personal audio device to take advantage of the inbuilt speakers with the 3.5mm 500mm long double-ended audio cable.

Warm-up & Preparation

To help prevent injury, have a good posture while using the iWalk.

For best results, wear footwear with high impact absorption and anti-slip features.

To help avoid injury, ensure you warm-up and cool down to prepare your body for your workout and reduce muscle pains after.

Using your iWalk™ The Family Treadmill

Manual Program

1. Turn on the treadmill.
2. Get on the treadmill and “===” should be displayed on the control panel, indicating “standby mode.”
3. Press the on/off button and the iWalk will begin working after 3 seconds.
4. To change the speed, press +/- . The speed will increase or decrease in small increments by 0.1.

Pre-set Program

1. Ensure the display is “===” which indicates the iWalk is in “standby mode”.
2. Press the mode button.
3. Press the speed +/- button to view the pre-established programs. Select a program (P1 to P6).
4. Once you have selected the program, you can choose a time setting by pressing the "Mode" button. To set a different time setting, press + or – until your desired time is displayed.
5. Press the On/Off button to operate the program according to your chosen mode and time setting.
6. Each program is divided into 20 sections of time equally in which you will notice different speeds.
7. Set up your iWalk to a pre-set program (see diagram on the next page).
8. An audible alert lasting 3 seconds will indicate the speed change.
9. You can view the speed, time, distance and calories burned on the screen by pressing MODE until the LED light comes on the desired option. If you choose the EXPLORER option the display will change between speed, time, distance and calories burned, changing every 5 seconds.
10. To stop your iWalk, remove the magnetic safety key. This will slowly bring your iWalk to a stop and the display will indicate with a flash that you have come to a halt.
11. Turn off the iWalk with the ON/OFF button.

Using your iWalk™ The Family Treadmill

P1 and P2 beginners programs:

Characteristics: Low speed variations. Best to start at this level.

Objective: Improve fitness and burn fat and calories at a low level.

P3 and P4 intermediate programs:

Characteristics: Medium speed variations. If your fitness levels have been approved, use one of these programs.

Objective: Improve fitness and burn fat and calories at a medium level.

P5 and P6 advanced programs:

Characteristics: High speed variations. If you have a high fitness level, these programs are for you.

Objective: Improve fitness and burn fat and calories at a high level.

Program	SPEED (km/h) Segment																			
P1	2	3	3	4	5	3	4	5	5	3	4	5	4	4	4	2	3	3	5	3
P2	2	4	4	5	6	4	6	6	6	4	5	6	4	4	4	2	2	5	4	2
P3	2	4	4	6	6	4	7	7	7	4	7	7	4	4	4	2	4	5	3	2
P4	3	5	5	6	7	7	5	7	7	8	8	5	9	4	5	6	6	4	4	3
P5	2	4	4	5	6	7	7	5	6	7	8	8	5	4	4	6	5	5	4	2
P6	2	4	3	4	5	4	8	7	5	7	8	3	6	4	4	2	5	4	3	2

Using your iWalk™ The Family Treadmill

After Use

Storing and folding your iWalk away safely:

1. Remove the Vertical beams locking bolt by turning anti-clockwise (see figure 1).
2. Lift the running belt to an upright position (see figure 2).
3. Pull out the folding pin and place it into the hole, securing the running belt upright to the Vertical beams (see figure 3).
4. Now you can move your iWalk. Hold the handlebars with both hands and lean the iWalk until the wheels touch the ground so you can move the iWalk.

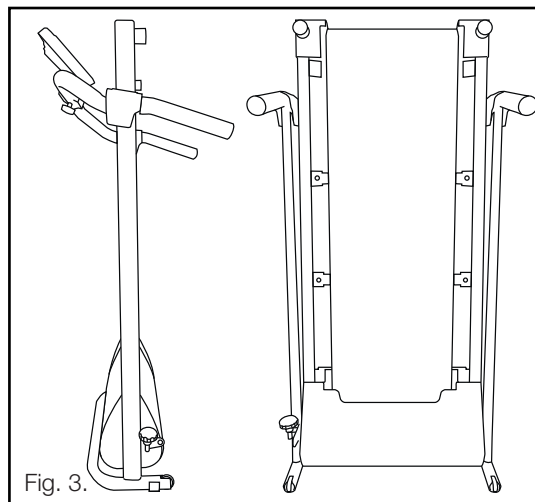
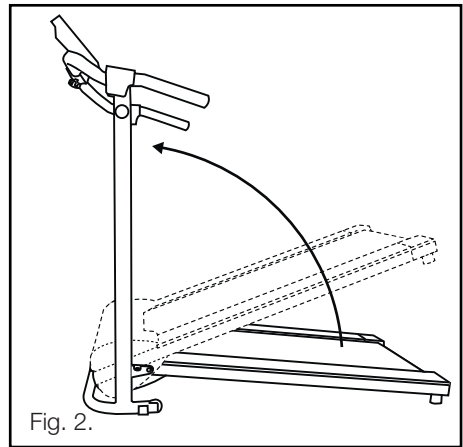
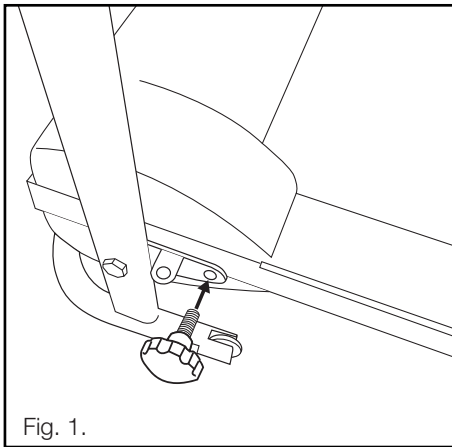

Cleaning & Care

Ensure your footwear is clean of any substances that can cause damage to the running belt.

Always use appropriate athletic footwear when using.

Clean with a damp cloth.

For best results sweeping or vacuuming under and around the iWalk, fold the treadmill up before doing so. This will get rid of dust that would be underneath when in use.

DO NOT use solvents when cleaning.

To remove stubborn stains, use a cotton cloth with mild cleaning detergent. Then use a dry cloth to ensure the iWalk is thoroughly dry.

DO NOT use any cleaning detergents on the control panel. Only use a dry cloth.

DO NOT unplug your iWalk while it is in use. Turn off by pressing the On/Off button on the Control Panel first and unplug once the running belt has come to a halt.

Cleaning and lubricating the running belt

The iWalk is lubricated beforehand but may

need topping up and cleaning underneath the running belt to maintain the performance and safety.

Ensure the product is off and unplugged before cleaning and maintenance.

To clean or lubricate the inside of the belt, you must loosen the belt as shown in Fig. 1.

Once loose, place your hand underneath the belt to either clean with a cloth or lubricate if necessary. Ensure the belt is fully tightened as shown in Fig. 2.

The belt may become loose or misaligned in transit. Please ensure it is fully tightened before use and regularly check the belt to ensure it is still tight.

Lubricant Warning & Advice: Silicone Oil (Polydimethylsiloxane) - Keep out of reach of children. Avoid prolonged contact with skin. Do not ingest. Avoid contact with eyes. Wash hands after use. Place approx 5-10ml on both sides, also reaching towards the centre to ensure a full spread. Wipe away any excess oil. Repeat if necessary. It is possible to lubricate without loosening the belts. If so, DO NOT stretch the belt too much as it may result in deforming or a rip. Turn the iWalk on for 3-4 minutes at 3kmph to allow the lubricant to spread.

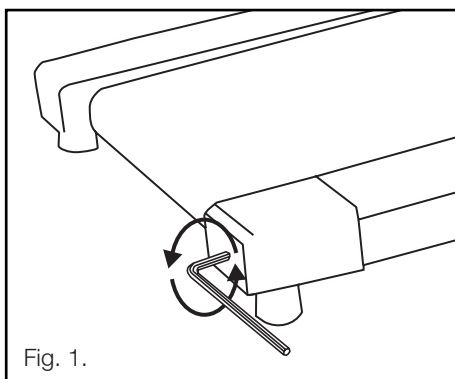

Fig. 1.

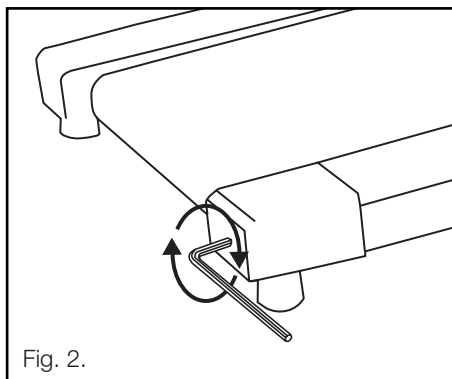

Fig. 2.

Guarantee

This product is unconditionally guaranteed for one year against all defects of workmanship and materials. This guarantee does not affect your statutory rights. If you have any problems or queries about this product please contact JML customer services.

Technical Information

How often the running belt needs to be lubricated depends on how often the iWalk is used per week

<3 hours per week	Every 6 months
3-6 hours per week	Every 3 months
>6 hours per week	Every month

Technical Specifications

Running area (WxL)	33.5cm x 101cm
iWalk net weight	22kg
Maximum user weight	110kg
Maximum speed	10km/h
Power consumption	500W
Power supply	220-240V~50Hz AC

Fuse & mains plug replacement (UK & Ireland only)

This appliance is fitted with a BS 1363 13-amp plug. If you have to replace the fuse, only use those that are ASTA or BSI approved to BS 1362 and have a rated current of 13 amps.

To change the fuse

1. Use a flat-head screwdriver to prise the cover off the fuse compartment.
2. Carefully remove the existing fuse.
3. Clip the new 13 amp fuse into place.
4. Clip the cover back firmly into place.

If the power cord is damaged in any way please contact JML Customer Services.

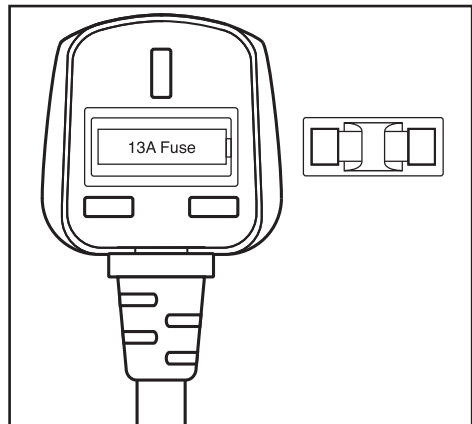

Disposal and the environment



This product is covered by the waste electrical and electronic equipment (WEEE) regulations. It should not be discarded with normal household waste, but taken to your local collection centre for recycling. For further information, please contact your local authority or approved disposal agency.



Distributed by JML

JML, Unit 1 Eastside, Port of Tyne, South Shields, NE33 5SP
Customer Services: UK: 0800 781 7831 (Freephone) • ROI: 041-978 0003 (Local rate)
Email: info@JMLgroup.co.uk • Web: www.JMLdirect.com

©JohnMillsLtd/HL/12.18/S001003/A • Made in China

