



USER MANUAL

IMPORTANT INFORMATION

Estimated Assembly Time: 45min (Approx.)

- Assembly requires 2 people.
- Please read through all instructions before starting assembly.



NOTE

- Please check you have the right number of parts before assembly.
- If you are missing any component, please contact +44 (0)1789 207419.
- Please retain your receipt as proof of purchase to validate your warranty.

CAUTION

- Do not tighten screws before all screws are in the right place.
- Do not use this product unless all bolts, screws and knobs are firmly secured.
- Check that all bolts, screws and knobs are securely tightened at least every 3 months.

WARNING

- If parts are missing, broken, damaged or worn stop using the product until all repairs are made using manufacturer authorised parts.
- Failure to follow these warnings could result in serious injury

DANGER

- **CHILDREN MUST BE SUPERVISED.**
- **The maximum load weight (rider together with the belongings) of this product is 120KG. This bicycle is not suitable for the fitting of a luggage rack or child seat. This bicycle is not suitable for use with a trailer.**

FCSI Limited | Timothy's Bridge Road | CV37 9NQ | United Kingdom

1. SAFETY

1.1 USE

Safety while riding your bicycle is of fundamental importance. Make sure you follow these simple rules:

- know the traffic rules (they vary in different countries).
- follow the prevailing flow of traffic and avoid cycling two-by-two.
- do not ride your bike on pavements and give priority to pedestrians.
- watch out for moving vehicles and for sudden opening of car doors.
- do not conduct cycling competitions on roads open to the traffic.
- do not carry passengers if your bikes are not equipped for it and make sure that this is allowed in your country. - always check the brakes are in working conditions and the general state of your bike.

WARNING: rain will reduce the effectiveness off the brakes; please allow longer distances to come to a halt.

- when changing direction, please make sure you indicate it with your arm.
- always keep your hands on the handlebar (except when signalling the change of direction).

1.2 AT NIGHT

For your safety, please take some extra precautions when using your bike at night:

- equip your bike with a complete and appropriate set of reflectors which are correctly installed. A light, which complies with the road rules of your country is also required.
- always ride as close as possible to the edge rather than the middle of the road.

1.3 OFF ROAD

Please observe the following precautions when using your bike off road:

- ride at reduced speed, avoid risks and wear an approved safety helmet.
- be extremely careful downhill. While braking the wheels lose adherence and an excessive use of brakes can lead to loss of control.
- be sure that the bike is in good working order before setting off.
- replace immediately any damaged component.

WARNING: jumps, acrobatics and any anomalous use can compromise the structure of the bike. Please consider this when approaching obstacles. Our products are designed to withstand heavy usage, but exceeding mechanical and physical limits becomes a danger for you and for others.

1.4 SUITABLE USE

Every bike has been designed and built for its specialised use.

Our bikes have been tested to support a maximum weight of 45kgs, which includes bike, rider and baggage. The maximal weight of baggage allowed is indicated on the carrier itself.

TYPE OF BIKE	TYPE OF JOURNEY	DISTANCE COVERED
GIRLS HERITAGE BIKE	Asphalted road, mountain off road, trail path.	Sporting, short and medium distance.

2. PREPARATION

- 2.1 Before using your new bike FOR THE FIRST TIME, please adjust the bike to your specific needs according to the following guidelines. Make sure the bike is correctly adjusted to your height and get to know its components and the reaction time.



1 FRAME - 2 TOP TUBE - 3 INCLINED TUBE - 4 SEAT TUBE - 5 REAR HORIZONTAL TUBE - 6 REAR INCLINED TUBES - 7 STEM - 8 FORK - 9 WHEEL - 10 TYRE - 11 TRACK - 12 VALVE - 13 RIM - 14 SPOKES - 15 HUB - 16 QUICK BLOCKING - 17 BB SET - 18 CRANK - 19 CHAIN - 20 PEDAL - 21 REAR DERAILLEUR - 22 FRONT DERAILLEUR - 23 SHIFTING LEVER - 24 FREE WHEEL - 25 HEAD SET - 26 STEM - 27 HANDLEBAR - 28 SEAT POST - 29 SADDLE - 30 BLOCKING - 31 BRAKE SHOES - 33 REFLECTOR - 34 BELL

Note - Above image stated is for demonstration purpose to know specific parts, actual cycle may differ from the above fig.

2.3 SEAT ADJUSTMENT

Please refer to fig. 2/3 for correct positioning of the seat. When pedalling, your big toe must lay on the centre of pedal axel and your knee should be slightly bent when the pedal lays on the lowest position.

Sit on the saddle and put the heel on the pedal, positioning it on the lowest position. In this position the leg should be completely straight (fig. 3). Check if you are able to touch the ground with the tip of your toes while seated, if not, lower again the saddle. Once the height of the saddle is correctly set, make sure that the blocking mechanism of the seat tube (13 Nm) and saddle (20/24 Nm) is correctly locked (fig. 4).

fig. 2

fig. 3

fig. 4

fig. 28

WARNING: A tag on the saddle tube indicates the maximum height. Make sure the tag is never visible. Insert the seat tube for at least 75 mm.

2.4 HANDLEBAR ADJUSTMENT

To rise or lower the stem (fig. 5), loosen the expander screw laying on the stem. Once the stem is loose, rise or lower to the preferred height. Keeping the stem in position, fix the expander screw tightly (20 Nm). To adjust the maneuverability of the handlebar, move screw B (fig. 6).

fig. 5

WARNING: Never set the height of the handlebar over the tag on the tube (fig. 7).

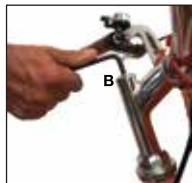
fig. 6

2.5 CHECK which brake lever, right or left, works the front brake and familiarize yourself with its use: inexperienced use of front brake may lead to loss of control.

2.6 CHECK that the pedals are correctly set. (see next chapter)

2.7 CHECK that the light is working correctly.

fig. 7

fig. 27

3. CONTROLS AND ADJUSTMENTS

BEFORE USING your bike, perform some checks as described below. If you have any doubts about the condition of your bike, contact your dealer for assistance.

3.1 CHECK THAT THE WHEELS ARE STRAIGHT.

Make each wheel spin and then observe the rim between the brake shoes: should the rim be out of centre (from left to right) or wobble from high to low, contact your dealer for advice.

3.2 CHECK THE TYRES.

Check that the tyre pressure is as marked on the side of the tyre. When pumping air into the tyre, take into consideration the rider's weight and possible loading, bear in mind that generally, a higher pressure gives the best performance on the road, whereas a lower pressure is better for off road. Replace worn-out or damaged track or sides of tyres.

WARNING: Check the fastening or the position of the tyres particularly after long downhill. Using your bike with the recommended air pressure in the tyres assures safety and endurance.

3.3 CHECK THE BRAKES

Check the brakes while at rest by pulling the levers with strength towards the handlebar. The brake lever must not touch the handlebar as this means the brakes are loose. For hydraulic disk brakes it should not be possible to pump with the brake lever. Should it happen, please contact your dealer. Always check the state of wear of the shoes.

WARNING: failure of braking system can lead to loss of control and injury.

3.4 CHECK THE FASTENING OF BOTH WHEELS.

The wheels of the bike have been fixed to the threaded axle of the hub with nuts.

fig. 26



WARNING: the bikes wheels must be firmly fixed to the frame and the fork.

3.5 CHECK HANDLEBAR AND STEM.

Carefully check the handlebar and stem in order to find out possible strain, cracks, deformities or dents and replace the damaged with nuts part before using the bicycle.

3.6 MAKE SURE THE KICKSTAND IS FOLDED BACK BEFORE STARTING TO PEDAL.

3.7 CALIPER BRAKE ASSEMBLY

Before the front wheel can be installed, the front brake must be loosened. This allows the front tyre to pass between the brake pads during assembly. When loosening the pinch bolt "C" the caliper is liable to spring open. Please take care.

Please take care.

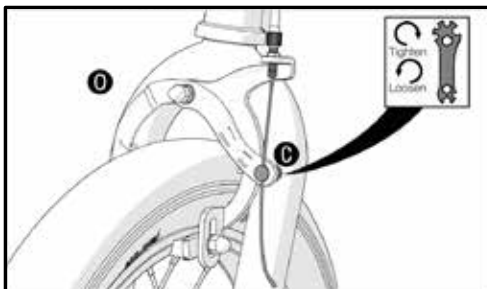

Disconnect the front caliper brake. Using the tool provided loosen the pinch bolt "C", as pictured. You only need to loosen the pinch bolt "C" to release the brake. It is not necessary to remove it completely.

Insert and secure the wheel. Loosen the wheel nuts (S) and position them at the ends of the axle (T). Slide the wheel retention washers (R) outwards so they are in contact with the wheel nuts. Insert the axle (T) of the front wheel into the slots at the bottom of the front fork – see diagram. Ensure the tabs of the wheel retention washers (R) are correctly positioned into their locating holes in the fork drop-outs. Tighten the wheel nuts (S) very tightly (22-25Nm) using the supplied multi-tool.

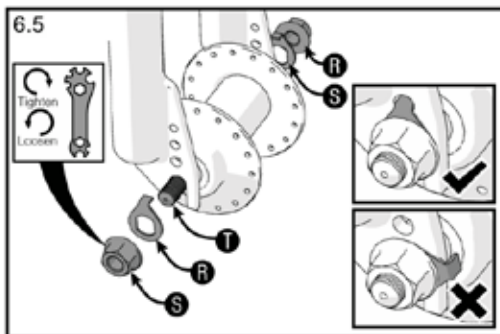

3.8 CENTRALISE WHEEL

Ensure the wheel is fully inserted and centralized in the forks before tightening wheel nuts. Some tyres have a "Direction of Rotation" arrow on their side. When the front wheel is assembled, the arrow should be pointing in the direction the wheel will rotate.

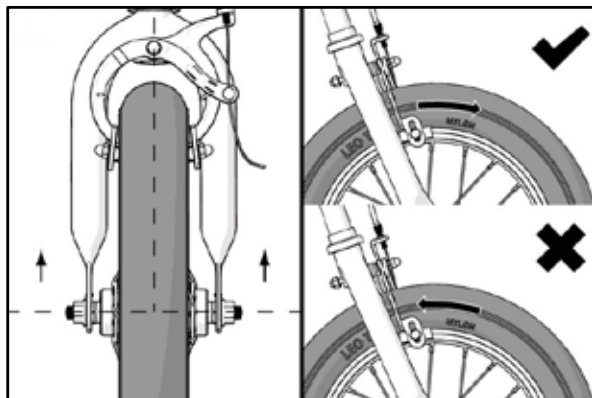

Reconnect the front calliper brake. See section 8.6 Adjusting Calliper brakes.

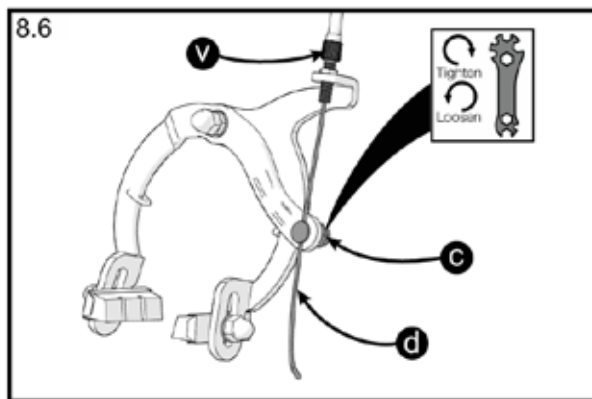

3.9 ADJUSTING CALIPER BRAKES

Adjusting Caliper brakes position Check that the calipers are aligned centrally. The brake blocks should be lined up with the rim equally on both sides of the caliper. To centralize the brakes, loosen the pivot point (c), reposition the caliper and re-secure it in place. When set up correctly there should be a 3-4mm space between each brake block and the rim. If the space needs adjusting, see 8.6 Adjusting Caliper Brakes.

Adjusting Caliper brake. The brakes must be adjusted so that the brake blocks are close to the rim when no pressure is applied to the lever. Loosen off the cable pinch bolt (c) using the tools provided, until the brake cabled is free to move. Pull the cabled through the pinch bolt so that the brake blocks are approximately 3-4mm from the wheel rim. Retighten the cable pinch bolt (c) whilst holding the brake cabled in position.

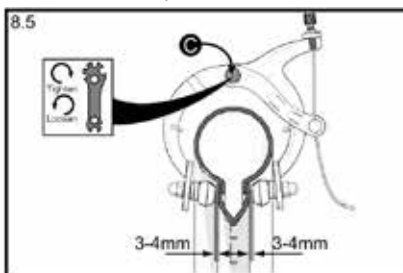

Adjusting Caliper brake pads. Check that the pads make full contact with the rim and do not touch the tyre. Ensure all parts are tightened correctly. Loosen brake pad nut (h) using the appropriate tool until the brake pad (g) is able to move. Align brake pad (g) with the wheel rim. Retighten the brake pad nut firmly. (8-10 Nm)

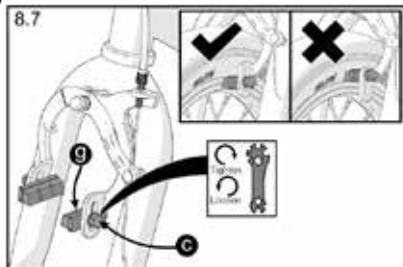

3.10 INSPECT BRAKES

All brakes should be checked before and after every ride. Inspecting brake blocks and rims. Inspect the grooves on the braking face of the brake block (g), releasing the brakes as shown in section 6 may be required. If the block has been worn smooth, then replace it with an appropriate block. It is also important to check the rim for wear, if the rim wear indicators has been worn

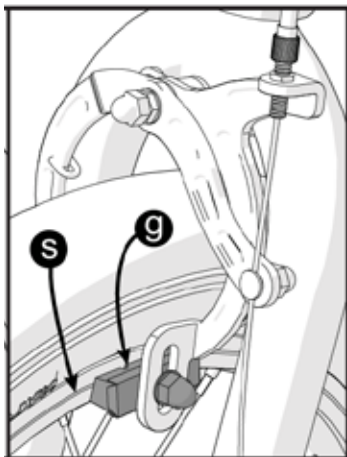

WARNING!

When replacing worn brake blocks and wheel rims it is essential to use parts that are fully compatible. If you are in any doubt about their suitability, we suggest you consult a qualified bicycle mechanic.

3.11 CHAIN AND FREEWHEEL

Chain and freewheel are components subject to most wear, but with regular cleaning, lubrication and using gear combinations (where the chain runs aligned), you can extend their duration. The usual limit of wear of the chain is from 1500 to 3000 km of riding. Failing to replace the chain would result in damages to the transmission parts (gears and chain ring). You can control the chain by lifting the biggest chain ring with your fingers, if the chain can be lifted up considerably, it means that it is too loose and it must be replaced. For a precise check of the chain and freewheel, refer to your dealer, as special tools and a perfect closure are needed.

WARNING: imperfectly closed or worn can easily break with serious consequences.

3.12 FRAME AND FORK

Check the frame and fork carefully in order to find out possible strain, clefts, other deformations or dents, because they can all be signal of structural fatigue. When cleaning the bike do not use solvents or corrosive chemicals, you could damage the painting. Remove any dirt using water, a soft detergent or a soft cloth dampened with a gentle cleaning product. Do not use high pressure jets to clean your bike as water can enter into bearings, causing corrosion.

The suspension forks must be lubricated regularly in order to guarantee their functioning and endurance. Spring or elastomer forks don't require any particular maintenance, but for hydraulic or air forks the manufacturer's manual needs to be followed carefully.

WARNING: Any kind of modification made to frame or fork will void the guarantee and could make riding dangerous.

3.13 HEAD SET

The fork and handlebar are integrated together by caps and bearings to allow smooth rotating motions: this is called head set. Vibrations from the road surface can loosen the head set and if not adjusted will cause damages to the bearings.

If you want to check if the head set is loose, activate the front brake and push the bike back and forward. Should there be an excessive movement together with a shock, the head set needs to be re-adjusted.

WARNING: Please refer to your dealer for adjustments to the head set, as special tools and knowledge are required.

3.14 WHEELS

Wheels are the intermediary between you and the road, so it is important to keep their maintenance in mind for your safety and for performance of your bike. You can prevent problems with regular checks. Before using your bike make sure the nuts of hub axle are correctly closed.

To remove the wheel (fig.15) ;

Loosen the fixing nut of the opposite parts. Now the wheel should be free to be removed from the chain stay. To re-fit the wheel, lay its axle between the chain stay. Then screw with your fingers the fixing nut on the opposite side till closing. Ensure that is correctly blocked by raising your bike and hitting hard on the wheel.

Observe that the wheel must not fall out, loosen or move to the side.

Check that the wheels are aligned and centred as described in chapter 3 point 1. Make sure there are no loose or broken spokes. Also check that the hub bearings are not loose by raising the front of your bike and trying to move the rim laterally to the right and to the left.

Spin the wheel to check if there are any unusual sounds affecting the hub. Check for signs of wear and tear of the rims of your bike, and on the braking surface which will appear like a continuous track around the rim. If the track cannot be seen, the braking surface is worn and it is necessary to replace the rim. If after these checks, you still have some doubts about the integrity of wheels or you have other concerns, ask your dealer for advice.



fig. 26

WARNING: make sure the braking surface of the rims are clean. Dirt and grease can affect the braking efficacy. Wash with water and soap and rinse or use a soft cloth dampened with a gentle cleaning product.



fig. 24



fig. 26

3.15 PEDALS (installation instructions)

The R marked pedal should be screwed clockwise on the right side crank, while the L marked pedal is to be screwed anticlockwise to the left crank. Tightly fix the pedals with a suitable key. Initially screw with your hand then complete the final rotations using the key. (clamping couple 35/40 Nm). If you want to check that the pedal bearings are in efficient condition, turn and move the pedals from the right to the left and up and down with your hands. If you see that the pedal bearings are too loose or rigid, refer to your dealer for assistance. Pedals with automatic blocking system need special shoes with studs for the hooking. To fix the foot to the pedal, put the front part of stud in the front part of the pedal and push down. To remove, turn the heel laterally. Make sure all fixing screws are tight, if a plate is loose it is quite impossible to get down from your bike. Follow manual instructions for adjustments.

WARNING: Check the correct clamping of pedals. Carefully follow the instructions in order to avoid damages to the pedal or crank threading and check the wear and tear of studs.



fig. 25

3.16 AFTER USING YOUR BIKE

The bike must be cleaned to work correctly. When not in use, protect the bike from elements such as rain, snow and sun. Atmospheric agents can corrode mechanic parts, sun can discolour the painting or damage the plastic and rubber parts. Before storing your bike for a long period, clean and lubricate it and clean the frame with a suitable protective polish. Hang up your bike with half-inflated tyres. Do not store your bike close to any electric engines as ozone gas can damage painting.

4. MAINTENANCE AND LUBRICATION

- 4.1** Correct and steady maintenance will increase the duration and reliability of your bike. After 200/400 Km or within 2 months from purchase, it is important to do the first check. This is because changes to the adjustments of some parts of your bike may occur (as a natural process) and the first inspection will improve the future functioning and endurance of your bike. With this in mind, please do not forget to organize the first check with your dealer.

It is also important to conduct your own maintenance at frequent intervals, which will depend on the prevailing weather, the kind of use, ground conditions and other factors. The program below is based on the normal use of bike. For more demanding usage, maintenance should be performed more frequently. If any parts appear damaged or abnormal, check them immediately and proceed with the correct maintenance below or refer to your dealer.

WARNING:

High temperatures harm your bike's composite materials. Prolonged exposure, like direct sunlight or confined storage, degrades these materials. Look for discoloration, cracks, or texture changes. Avoid heat sources, inspect regularly, and act promptly for safety and performance.

COMPONENT	MAINTENANCE	PRODUCT	FREQUENCY
FRAME	Control and cleaning	Water + protective polishing detergent for frames	1 month 6 months
FORK	Control, lubrication and cleaning	See supplier manual	15 days
WHEELS	Control and cleaning	Cloth with gentle cleaning products for paintings	1 month
HUBS	Hubs lubrication	Grease for bearings	1 year
TYRES	Control		1 month
BRAKES & LEVERS	Control and lubrication of articulations	Spray oil	3 months
CABLES & CASINGS	Control and lubrication	Synthetic grease for chains	6 months
CHAIN & FREEWHEEL	Control, cleaning and lubrication	Synthetic grease for chains	1 month
BB SET	Disassembly and lubrication	Grease for bearings	1 year
REAR DERAILLEUR	Control, cleaning, adjustment and lubrication	Synthetic grease for chains	1 month
SHIFTING LEVERS	For the maintenance of these parts refer to your dealer.		1 year
HEAD SET	Control	Grease for bearings	1 year
PEDALS	Control and lubrication	Grease for bearings	3 months
SEAT POST	Control and lubrication	Grease with low viscosity	1 year
LIGHTING SET AND REFLECTORS	Control and cleaning	Damp cloth	Every journey
BOLTS AND NUTS	Check the clampings		1 month

Please use **BIODEGRADABLE** maintenance products where possible such as grease, oil, degreasing agent, lubricant, etc. Please keep the environment in mind.

4.2 FIXING OF THE PRINCIPAL SCREWS AND NUTS

During usage, because of vibrations, some screws can be loosen. We suggest periodic checking of screws to ensure they are fastened tightly. Replace immediately any damaged or lost part. We list the suggested fastening pairs, expressed in Newton-meters (Nm); we remind you that in order to carry out this operation correctly, you need a dynamometrical key, which breaks off when the fastening pair is reached

Nut/ing front hub	20-27 Nm
Nut/wing back hub	27-33 Nm
Saddle clamp nut	20-24 Nm
Brake fixing bolt	7-10 Nm
Brake shoe fixing bolt	5-8 Nm
Seat post tube bolt	10-14 Nm
Handlebar expander bolt	18-20 Nm
Rear derailleur bolt	8-15 Nm
Front derailleur bolt	5-7 Nm
Stem bolt ahead set	10-14 Nm
Caliper bolt	6-8 Nm
Crank screw	34-44 Nm
Handlebar brake lever screw	6-8 Nm
Automatic pedal studs screw	5-8 Nm
Clamp stem M6	12-14 Nm
Clamp stem M8	4-18 Nm
Pedals	34-40 Nm

5. WARRANTY

5.1 Pre-requisite for the guarantee is correct use of the bicycle, a control check within the first 500 Km or within four months from the date of purchase and a general maintenance performed once in a year by a dealer.

The product is guaranteed without any material or production defects for 24 months from the actual delivery date to the buyer.

The guarantee consists of the free replacement and/or repair of parts recognised by the dealer as having manufacturing defects. The buyer has no right to ask for the cancellation of the contract, compensation or for reduction on the price.

The guarantee does not include costs of manpower, transport or costs as consequence of defects. Requests under guarantee must be presented to the seller and a receipt must be presented. The guarantee applies only to the buyer and is not transferable. With the exclusion of cases defined by the law, the manufacturer is exempt from every responsibility and obligation for any accident to people or properties that has occurred during the use of the vehicle.

5.2 LIMITATIONS

The guarantee is not valid for damages caused by: accidents, negligence, tampering, lack of maintenance, improper use of the vehicle, corrosion, use of no original spare parts, wear and tear due to the use of vehicle, acrobatic activities, change or reparation of the frame and/or of the components and the running of the vehicle.

(We remind you that because of technical progress, the producer reserves the right to modify components, details or accessories. Images, descriptions and dates are not to be considered binding.)

Thank you for your purchase. Please retain your receipt to validate warranty.



USER MANUAL INDEX

1. SAFETY	PAGE 02
2. PREPARATION	PAGE 04
3. CONTROLS AND ADJUSTMENTS	PAGE 06
4. MAINTENANCE AND LUBRICATION	PAGE 15
5. WARRANTY	PAGE 18

Manufactured under licence by:

FCSI Limited | Timothy's Bridge Road | CV37 9NQ | United Kingdom