

Clothes Rail

Assembly Instructions - please keep for future reference

806/9407

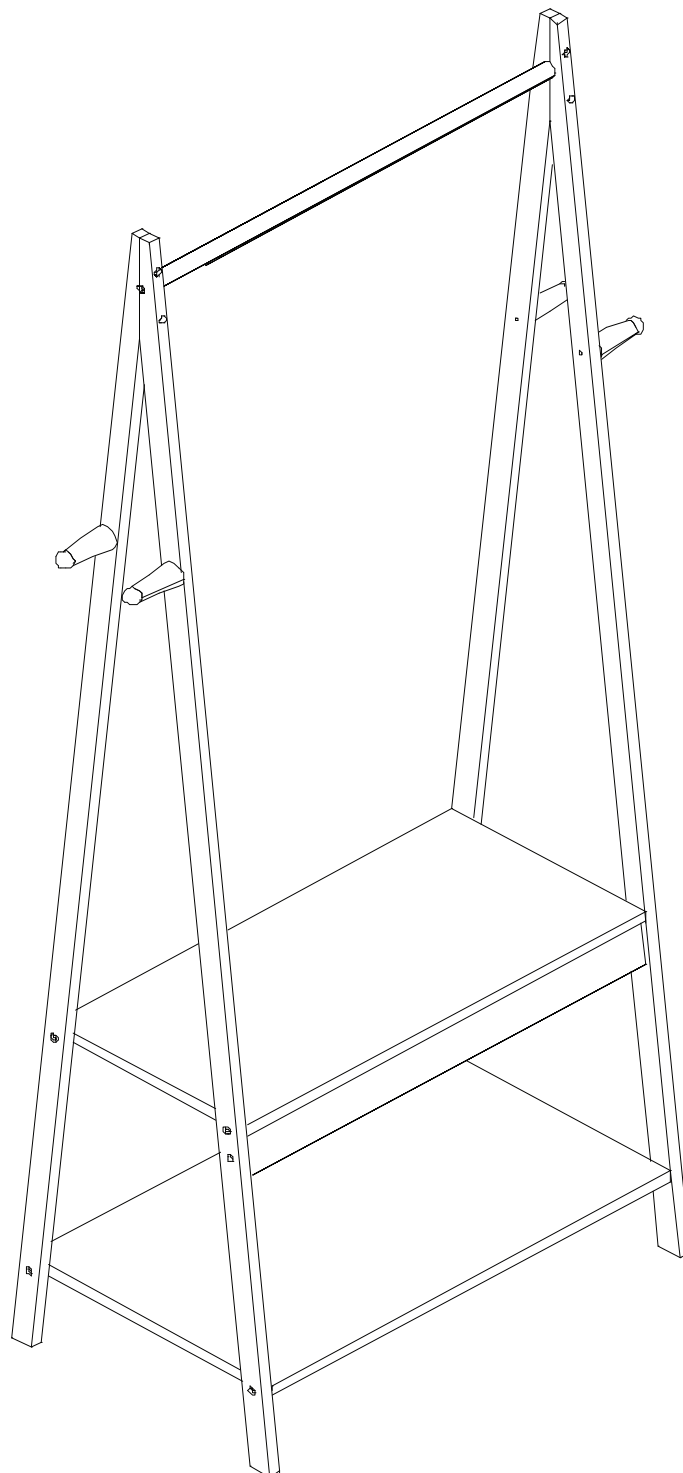

Dimensions

Width - 63.5cm

Depth - 40cm

Height - 164cm

Important – Please read these instructions fully before starting assembly

If you need help or have damaged or missing parts, call the Customer Helpline: 0345 640 0800



Safety and Care Advice

Important – Please read these instructions fully before starting assembly

- Check you have all the components and tools listed on page 2
- Remove all fittings from the plastic bags and separate them into their groups.
- Keep children and animals away from the work area, small parts could choke if swallowed.
- Make sure you have enough space to layout the parts before starting.

- During assembly do not stand or put weight on the product, this could cause damage.
- Assemble the item as close to its final position (in the same room) as possible.
- Assemble on a soft level surface to avoid damaging the unit or your floor.
- Parts of the assembly will be easier with 2 people.



- We do not recommend the use of power drill/drivers for inserting screws, as this could damage the using. Only use hand screwdrivers

Care and maintenance

- Only clean using a damp cloth and mild detergent, do no use bleach or abrasive cleaners.
- From time to time check that there are no loose screws on this unit.
- This product should not be discarded with household waste. Take to your local authority waste disposal centre.

Handy Hints

- Assemble all parts and bolts loosely during assembly, only once the product is complete should you fully tighten the bolts
- Regularly check and ensure that all bolts and fittings are tightend properly.

Components - Panels

Please check you have all the panels listed below

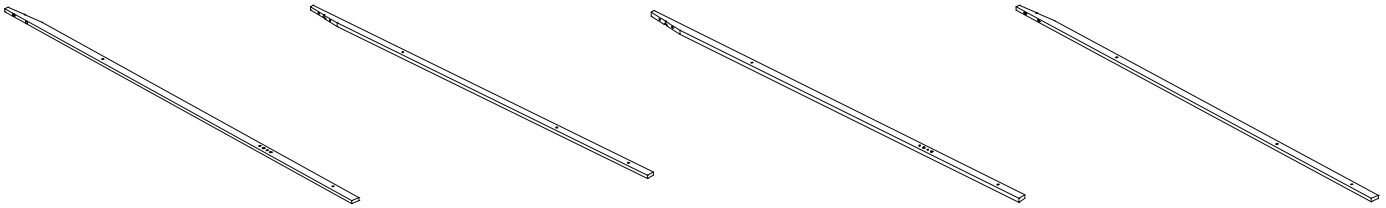

1 Front Left Bar x 1
166cm x 3.5cm x 1.8cm

2 Rear Left Bar x 1
166cm x 3.5cm x 1.8cm

3 Front Right Bar x 1
166cm x 3.5cm x 1.8cm

4 Rear Right Bar x 1
166cm x 3.5cm x 1.8cm

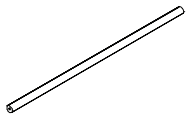

5 Top Rail x 1
60.3cm x 2.4cm

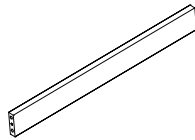

6 Front Bar x 1
60.3cm x 6.1cm x 1.2cm

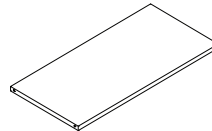

7 Top Shelf x 1
60.5cm x 28cm x 1.2cm

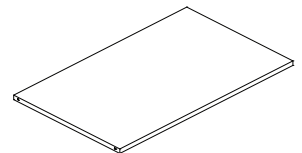







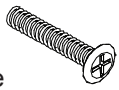

8 Bottom Shelf x 1
60.5cm x 37cm x 1.2cm

Components - Fittings

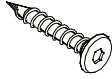
If you have damaged or missing components, call the Customer Helpline: 0345 640 0800

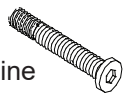
Please check you have all the fittings listed below

Note: The quantities below are the correct amount to complete the assembly. In some cases more fittings may be supplied than are required.

<p>A</p>  <p>45mm Machine Screw x 4</p>	<p>B</p>  <p>Female Threaded Boss x 4</p>	<p>C</p>  <p>40mm Hex Head Screw x 6</p>	<p>D</p>  <p>30mm Dowel x 4</p>
<p>E</p>  <p>40mm Machine Screw x 10</p>	<p>F</p>  <p>Barrel Nut x10</p>	<p>G</p>  <p>Allen Key x 1</p>	<p>H</p>  <p>Hooks x 4</p>

Tools required

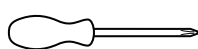

Phillips screwdriver
(medium & large)

Ruler – Use this ruler to help correctly identify the screws

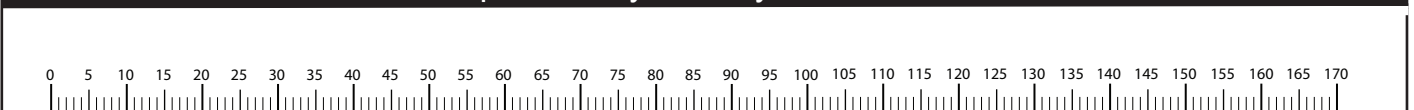

Assembly Instructions

Step 1

1. Connect Uprights Bars **1** and **2** as shown using 2 x Screws **A** and 2 x Female Threaded boss **B** as shown

2. Connect Uprights Bars **3** and **4** as shown using 2 x Screws **A** and 2 x Female Threaded boss **B** as shown

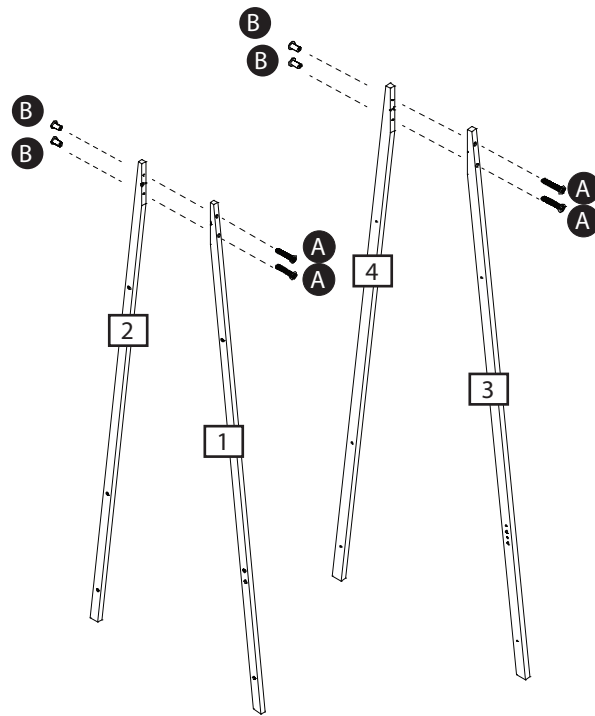

Step 2

1. Into Front Bar **6** insert 4 x Dowels **D**

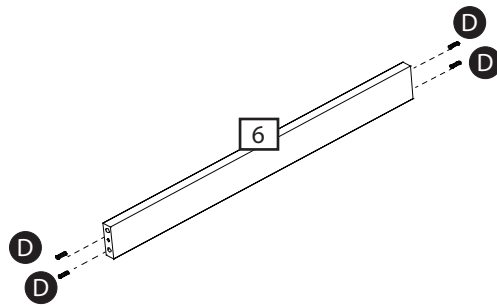

Step 3

1. Into Panels **6** **7** and **8** insert 5 x Barrel Nuts **F**

2. Connect Bars **1** and **2** to Panels **6** **7** and **8** with 4 x Screw **E** using Allen Key **G** provided

3. Connect Top Rail **5** using 1 x Screw **C**

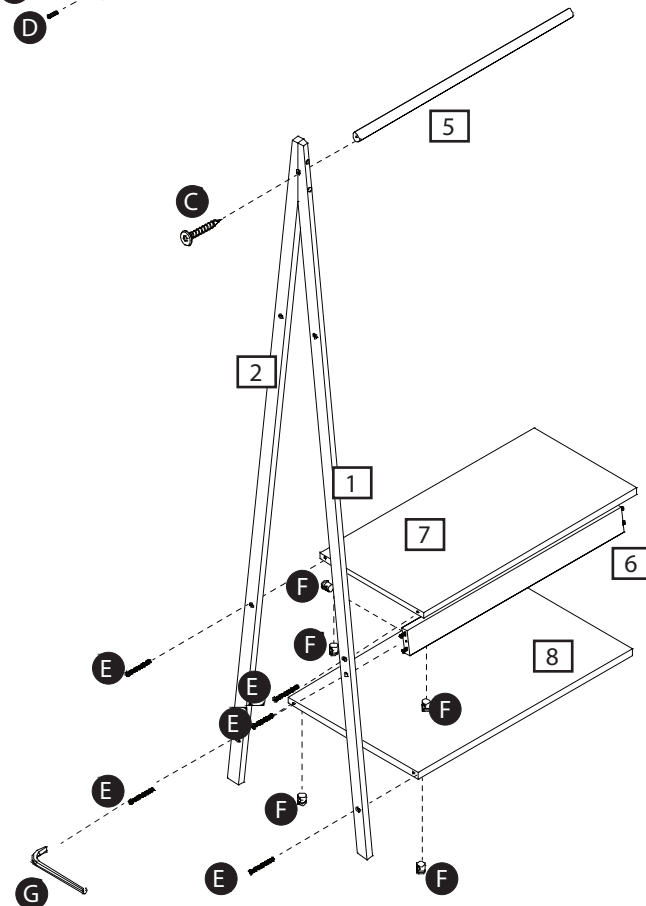

Assembly Instructions

Step 4

1. Into Panels **6** **7** and **8** insert 5 x Barrel Nuts **F**

2. Locate bars **3** and **4** onto Panels **6** **7** and **8**

3. Connect Bars **3** and **4** to Panels **6** **7** and **8** with 4 x Screw **E** using Allen Key **G** provided

4. Connect Top Rail **5** using 1 x Screw **C**

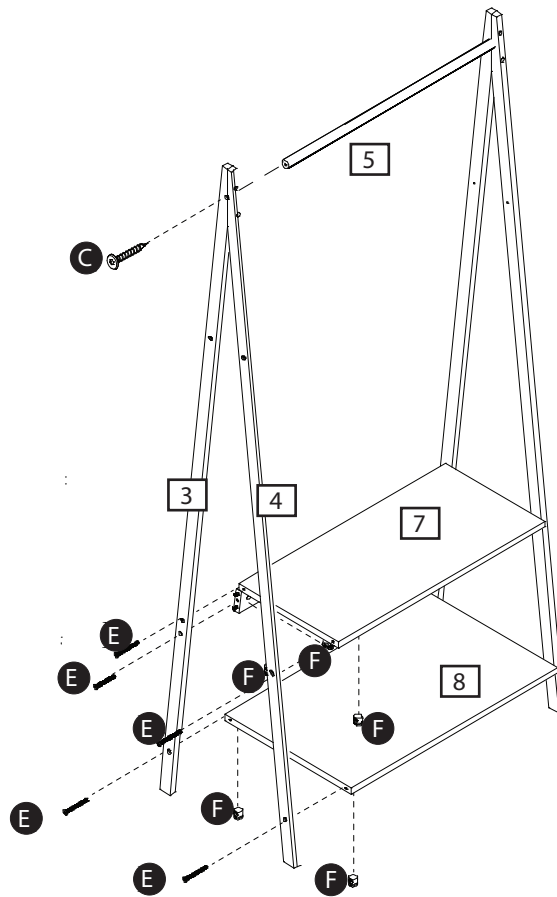

Step 5

1. Connect 4 x hooks **H** to Uprights bars using 4 x Screw **C** as shown.

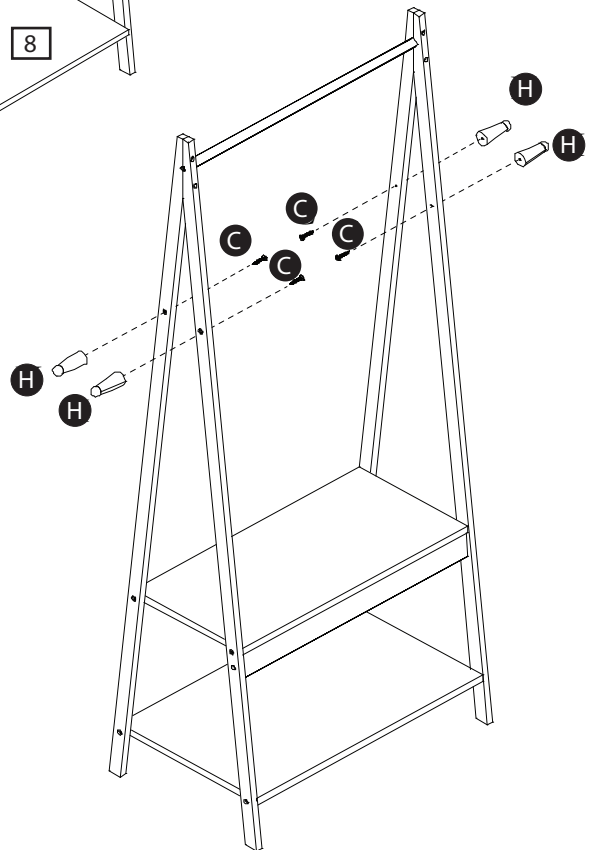

Assembly Complete

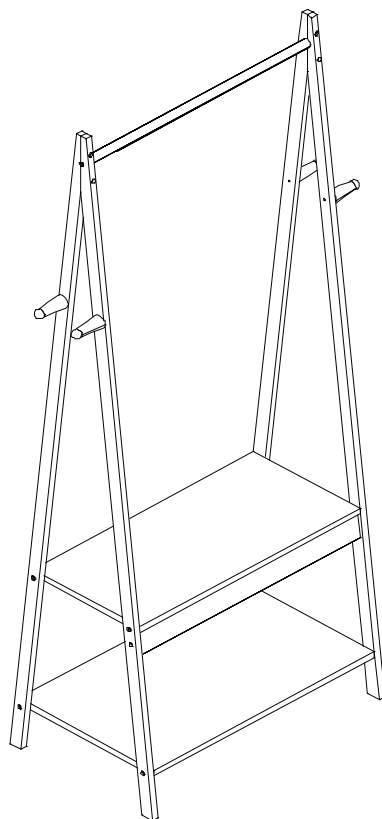

If you need help or have damaged or missing parts, call the **Customer Helpline: 0345 640 0800**
Argos LTD. 489-499 Avebury boulevard, Central Milton Keynes, MK9 2NW