

cookworks

Instruction Manual - Please keep for future reference

Cookworks Food Slicer

Model No.:S892

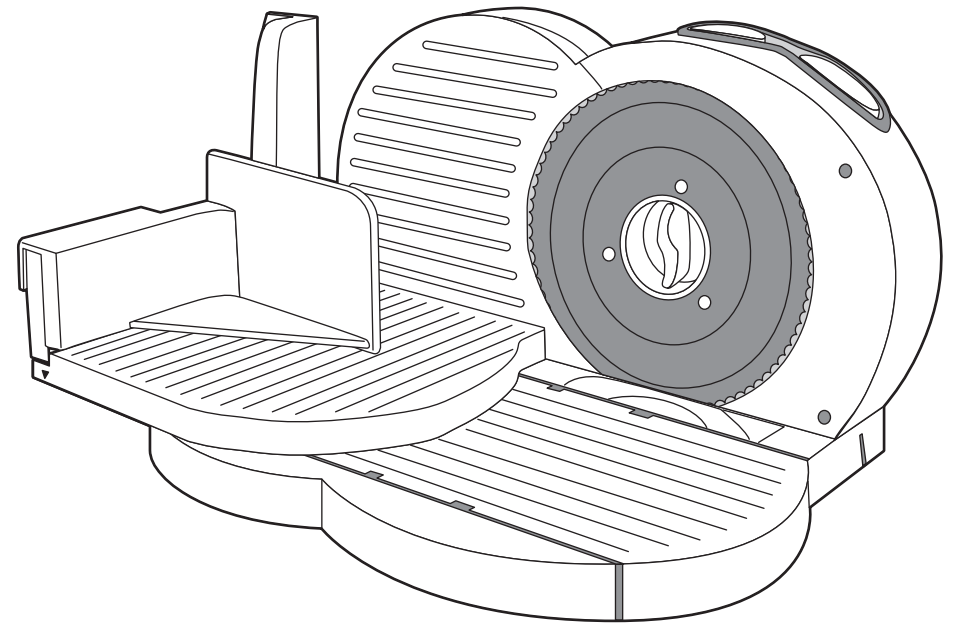

IMPORTANT SAFETY INSTRUCTIONS

Read all instructions before use and keep for future reference.



WARNING - To reduce the risk of fire or electric shock, do not expose this appliance to rain or moisture or submerge into water.



CAUTION - Use of controls or adjustments or performance of procedures other than those specified herein may result in a hazard.

PRECAUTIONS

To Maintain Optimum Performance

Do not use the unit in places which are extremely hot, cold, dusty or humid.

For safety

- Take care not to drop the unit or subject it to strong shocks.

Children

- Children do not understand the dangers associated with operating electrical appliances. Never allow children to use this appliance.

Mains Lead

- If this unit has a mains lead or is connected with a mains adaptor do not allow the lead to become strained or damaged as it creates a hazard.

Ventilation Warning

- Do not allow water or liquids to splash onto the main body as it contains live parts.
- Do not cover the body with a cloth and allow the unit to be well ventilated.



Electrical Requirements

Check that the voltage on the rating plate of your product corresponds with your house electricity supply which must be A.C. (Alternating Current).

If the socket outlets in your home are not suitable for the plug supplied with this product, check with a qualified electrician for replacement.

Warning

- This appliance is not intended for use by persons (including children) with reduced physical, sensory or mental capabilities, or lack of experience and knowledge, unless they have been given supervision or instruction concerning use of the appliance by a person responsible for their safety.
- Children should be supervised to ensure that they do not play with the appliance.

IMPORTANT SAFETY INSTRUCTIONS

- Switch off the appliance before changing accessories or approaching parts which move in use.
- This appliance must be used with the sliding feed table and the piece holder in position unless this is not possible due to the size or shape of the food.
- Do not operate any appliance with damaged cord or plug, or if appliance malfunctions or is damaged in any manner.
- If the supply cord is damaged, it must be replaced by the manufacturer, its service agent or similarly qualified persons in order to avoid a hazard.
- This appliance can be used by children aged from 8 years and above and persons with reduced physical, sensory or mental capabilities or lack of experience and knowledge if they have been given supervision or instruction concerning use of the appliance in a safe way and understand the hazards involved. Children shall not play with the appliance. Cleaning and user maintenance shall not be made by children without supervision.
- Always disconnect the appliance from the supply if it is left unattended and before assembling, disassembling or cleaning.
- This appliance shall not be used by children. Keep the appliance and its cord out of reach of children.

OPERATION

PLEASE REMEMBER:

- Do not operate the product if under the influence of alcohol or drugs. Read warning labels on prescriptions to determine if your judgment/reflexes might be impaired.
- Do not wear loose clothing or jewelry as they can be caught in moving parts.
- Wear restrictive hair covering to contain long hair.

WORK AREA

TO AVOID RISK OF PERSONAL INJURY, EQUIPMENT DAMAGE OR FIRE AND SHOCK:

- Do not use in wet or damp environments.
- Children should not be allowed into the work area.
- The work area should well-lit clean, and free from obstructions.

Read all instructions before use and keep for future reference.



SLICER FUNCTION

This unit contains a very sharp slicing Blade. Extreme caution should be used at all times when operating this appliance.

Keep your fingers, hands, hair and other body parts away from the Blade.

Always use the "Protective Guide" and "Food Tray".

Only use this slicer to cut soft food any other use will result in a hazard..

Do not run continuously for longer than 3 minutes. Turn it off and let it cool down at least 5 minutes; otherwise the motor may become damaged.

Know Your Machine6

Assembly.....7

Operation.....9

Specifications13

Ⓐ 1 x Food Slicer

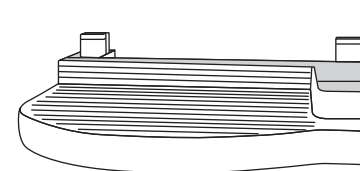
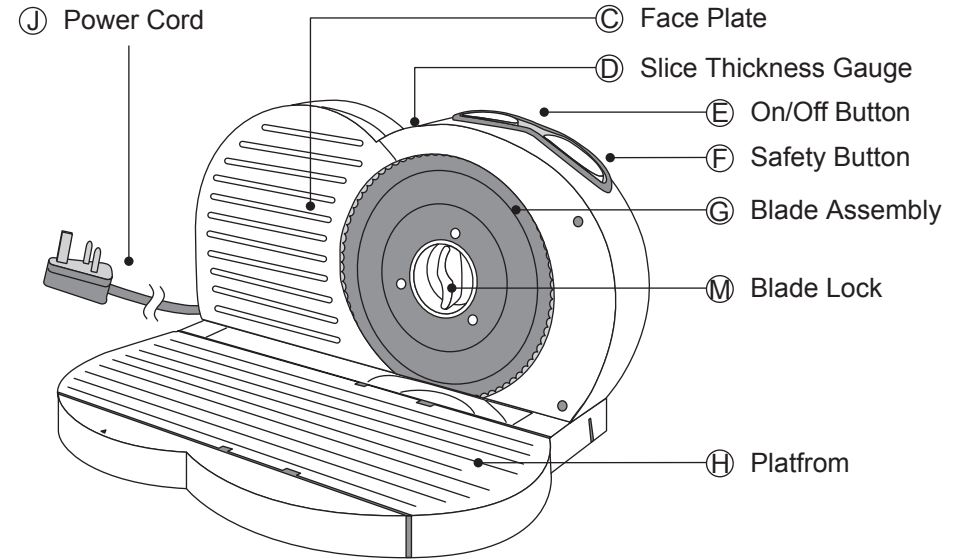
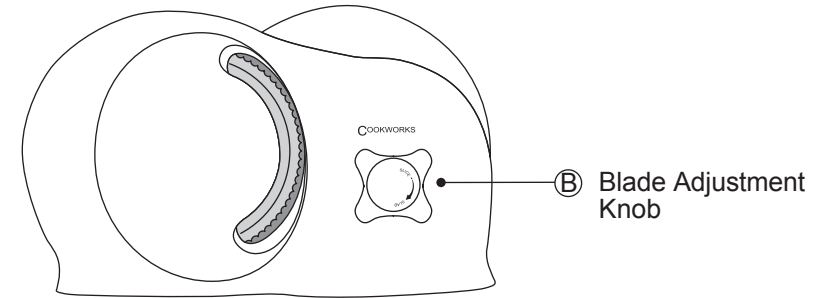

Ⓚ 1 x Food Tray

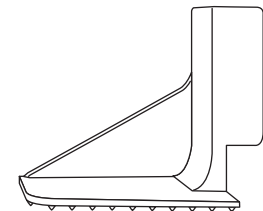

Ⓛ 1 x Protective Guide

ASSEMBLY

⚠ Before Operating

- Unplug appliance when not in use and before cleaning.
- Do not use appliance for uses other than those recommended.
- To protect against electrical shock, do not immerse cord, plug, motor, motor stand, motor base, main body or platform in water or any other liquid. Only use the Food Slicer on a dry, water-free work surface. Always stand on a dry, insulated surface while using.
- Avoid contact with moving parts! Never feed food by hand. Always use the Protective Guide.
- Do not use the Food Slicer outdoors.
- The Blade is sharp. Be extremely careful when cleaning blade and when the blade is spinning during operation.
- Never use Steel Wool or scouring powder on any part of the Food Slicer.
- **DO NOT MODIFY YOUR PLUG IN ANY WAY. IF YOU HAVE ANY DOUBT. CALL A QUALIFIED ELECTRICIAN**

Food Hygiene

CAUTION: To reduce risk of health hazards; Before assembling the Food Slicer, thoroughly wipe off all parts with a clean cloth using warm soapy water and a mild anti-bacterial detergent. In addition, the following parts should be cleaned in hot soapy water: Protective Guide (L), Blade Assembly (C) and Food Tray (K).

After assembling the unit, test the Food Slicer by running several slices of day-old bread through the Food Slicer to insure that all parts are working properly. Clean the Food Slicer after every use. **Failure to follow all cleaning instructions and warnings may result in serious illness due to food poisoning.**

Assembly

- Your Food Slicer will require assembly prior to use. It is important that you read the entire manual to become familiar with the unit BEFORE you set up the Food Slicer.
- The Food Slicer must be cleaned, as described above, before the first use and after all subsequent uses.

ASSEMBLY

⚠ NOTES:

- **Please read the important safety instructions before use.**

1. Unfold the Platform (H) from the Food Slicer (A).
See fig. 1.

2. Slot the Food Tray (K) into the Platform (H).
See fig. 2.

3. Slide the Protective Guide (L) onto the Food Tray (K).
See fig. 3.

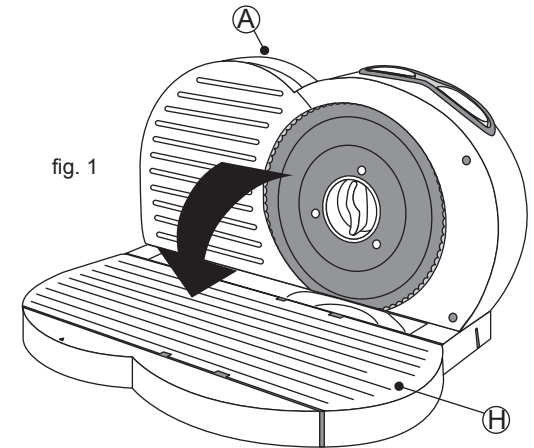

fig. 1

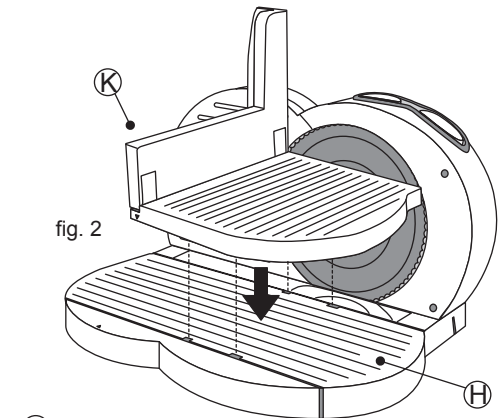

fig. 2

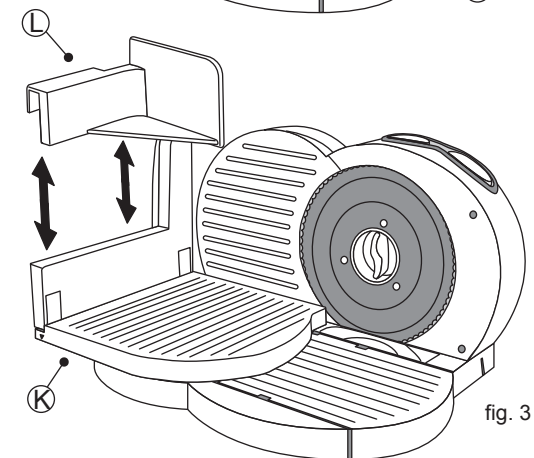

fig. 3

OPERATION

NOTE: Make sure your local voltage is 220-240V 50/60Hz.

1. Insert the Power Cord (J) into the mains socket.
2. Set the Blade Adjustment Knob (B) for the thickness of the slice that you desire. Turn the Blade Adjustment Knob (B) clockwise for thicker slices and counterclockwise for thinner slices.

See fig. 4.

3. Slide the Food Tray (K) away from the Blade (G). Place the food to be sliced on the Food Tray (K), positioned between the Face Plate (C) and Protective Guide (L).

See fig. 5.

CAUTION: Keep fingers away from the Blade Assembly (G) at all times.

4. In order to turn on the Food Slicer slide the ON/OFF Button (E), from 0 to 3. 0 is "off" 3 is "Maximum". Then push the Safety Button (F).

See fig. 6.

5. Set the On/Off Button (E) to 1,2,3 which relates to Slow, Medium, Max Blade Speed. Adjust depending on your requirements.

See fig. 6.

NOTE: You need to continually push down the Safety Button (F) to keep the Blade spinning.

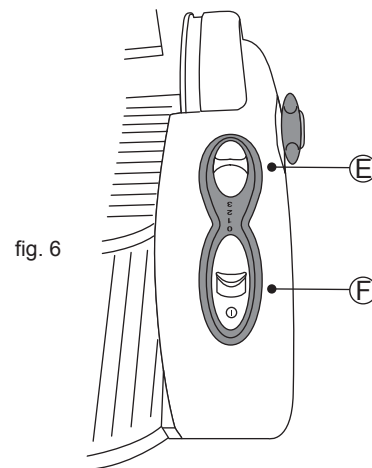
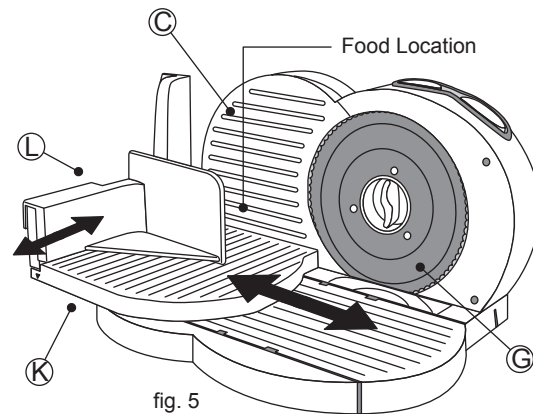
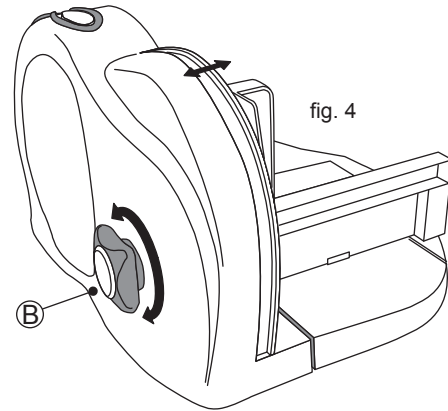

OPERATION

5. Use your other hand to hold the Protective Guide (L) with your thumb protected behind thumb guard. Apply gentle pressure onto the Protective Guide to keep the food pressed against the Face Plate (C). Then to cut the food slide the Food Tray (K) back and forth steadily across the Blade Assembly (G).

See fig. 7.

NOTE: The Blade only cuts during the forward motion.

CAUTION: Keep fingers and hands behind the Protective Guide (L) and clear of the spinning Blade Assembly (G).

6. Place a Food Tray to the outside of the unit to catch the food as it is being sliced.

See fig. 8.

7. To turn off the Food Slicer, take fingers off of the Safety Button (F) and slide On/Off Button (E) to zero.

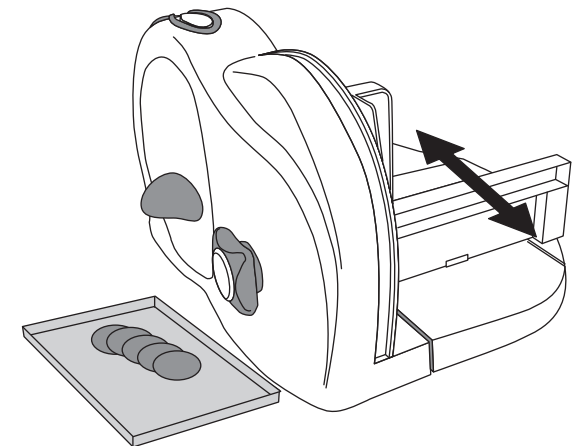
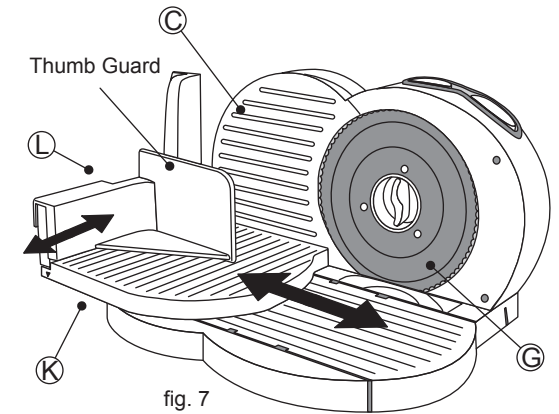

OPERATION

CLEANING

Removing and Replacing the Blade

CAUTION: Take care when removing or replacing the blade as the edge may be very sharp.

1. Make certain that the Food Slicer is OFF and UNPLUGGED. Turn the Blade Lock (M) clockwise to unlock it. Pull out the Blade Assembly (G). See fig. 9.

CAUTION: Before first use and after every use, clean the Blade and Assembly.

2. To reinsert the Blade Assembly (G), line up the tabs on the Blade Assembly (G) with the slots in the Small Gear. Once the Blade Assembly is seated with the Small Gear, turn the Blade Lock (M) anticlockwise to lock it in position. See fig. 10.

NOTE: Only use this appliance to cut soft foods, Do not use to cut frozen foods, bones or other solid food types.

For Best Results

- Chill meats thoroughly before slicing.
- Slice meats thinly.
- Meats should be boneless.
- Fish and thin steaks will slice better if partially frozen.
- When slicing warm roasts, make certain to remove all string before slicing.

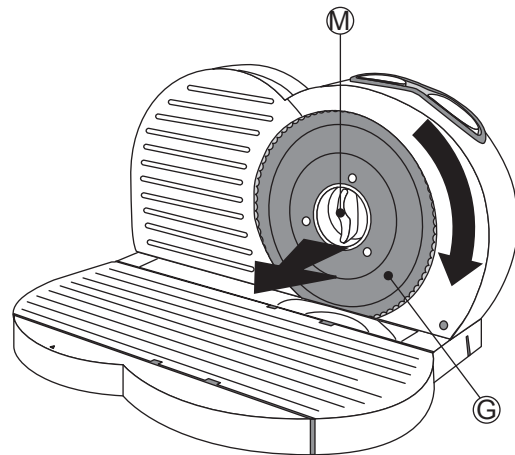

fig. 9

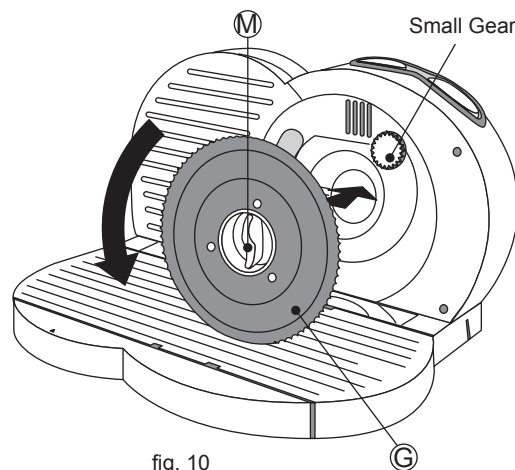

fig. 10

OPERATION

After Operation-Maintenance

1. Never use Steel Wool or scouring powder on any part of the Food Slicer.
2. Ensure the unit is hygienically clean. Before assembling the Food Slicer, and with the unit unplugged, thoroughly wipe off all parts with a clean cloth using warm soapy water and a mild anti-bacterial detergent. In addition, the following parts should be removed and cleaned in hot soapy water: Protective Guide (L), Blade Assembly (G), and Food Tray (K). Clean the Food Slicer after every use. See fig. 11.

NOTE: Failure to follow all cleaning instructions could allow harmful bacteria to grow and contaminate food, creating a serious health risk.

STORAGE:

- Remove the Protective Guide (L) and Food Tray (K), Fold up the Platform (H) against the Main Body. Wrap up the Cord (J) and store it under the Food Slicer. The Food Slicer should be stored in a location that is out of reach of children in a clean dry environment. See fig. 12.

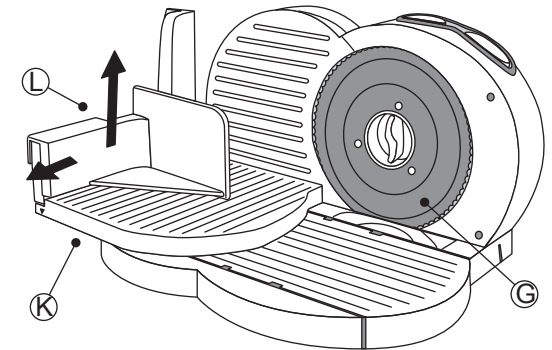

fig. 11

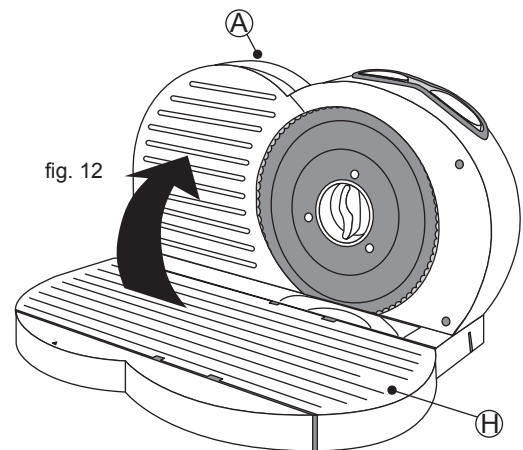

fig. 12

SPECIFICATIONS

Technical Data

Model no.	S892
Power Supply	220-240V~ 50/60Hz 150W
Blade	Stainless Steel
Blade RPM	95
Blade Diameter	6-1/2"
Slice Thickness	Adjustable 0-15mm
Weight	4kg

Connecting to Power

Check that the voltage marked on the product corresponds with your supply voltage. This product is fitted with a 13A plug complying with BS1363. If this plug is unsuitable or needs to be replaced, please note the following :

Plug Replacement

If you need to replace the fitted plug.



WARNING :

Never connect live or neutral wires to the earth terminal of the plug. Only fit an approved 13 Amp BS1363/A plug and the correct rated fuse. If in doubt, consult a qualified electrician.

IMPORTANT

The wires in this mains lead are coloured as follows:
Blue-Neutral
Brown-Live

As the colours of the wires in the mains lead of this apparatus may not correspond with the coloured markings identifying the terminals in your plug, proceed as follows:

The wire which is coloured blue must be connected to the terminal, which is marked with N or coloured blue. The wire which is coloured brown must be connected to the terminal which is marked L or coloured brown. Always ensure that the plug cord grip is fastened correctly. If a 13A (BS1363) fused plug is used it must be fitted with a 3A fuse conforming to BS1362 and be ASTA approved. If in doubt contact a qualified electrician.

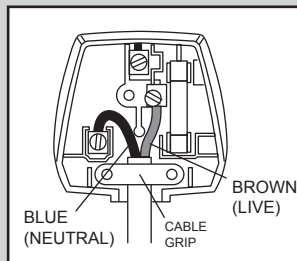

This marking indicates that this product should not be disposed with other household wastes throughout the EU. To prevent possible harm to the environment or human health from uncontrolled waste disposal, recycle it responsibly to promote the sustainable reuse of material resources. To return your used device, please use the return and collection systems or contact the retailer where the product was purchased. They can take this product for environmental safe recycling.



PRODUCT GUARANTEE

This product is guaranteed against manufacturing defects for a period of



This product is guaranteed for twelve months from the date of original purchase. Any defect that arises due to faulty materials or workmanship will either be replaced, refunded or repaired free of charge where possible during this period by the dealer from whom you purchased the unit.

The guarantee is subject to the following provisions:

- The guarantee does not cover accidental damage, misuse, cabinet parts, knobs or consumable items.
- The product must be correctly installed and operated in accordance with the instructions contained in this manual.
- It must be used solely for domestic purpose.
- The guarantee will be rendered invalid if the product is re-sold or has been damaged by inexpert repair.
- Specifications are subject to change without notice.
- The manufacturer disclaims any liability for the incidental or consequential damages.
- The guarantee is in addition to, and does not diminish your statutory or legal rights.

Guarantor: Argos Ltd
489 - 499 Avebury Boulevard
Central Milton Keynes
MK9 2NW