

**Overlap Cladding**

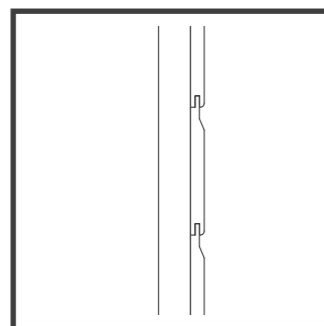

**Shiplap Cladding**

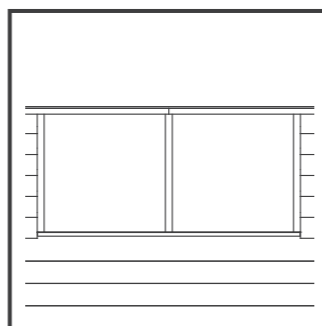

**Fixed Windows**

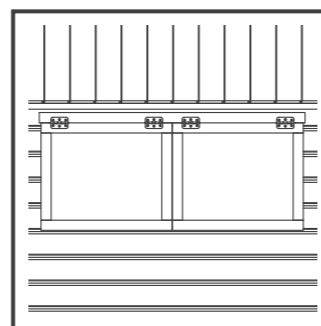

**Opening Windows**

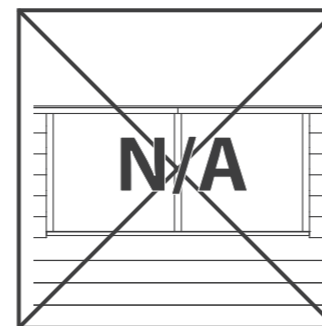

**No Windows**

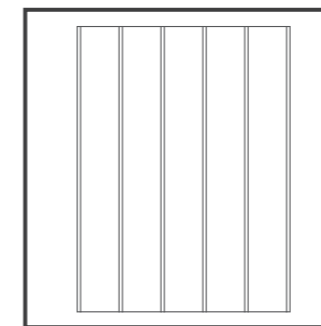

**Solid Sheet Floor**

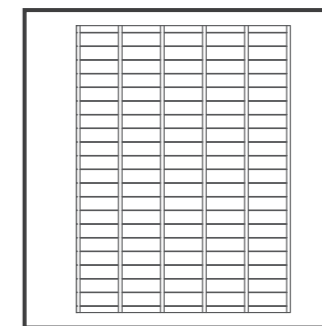

**T&G Floor**

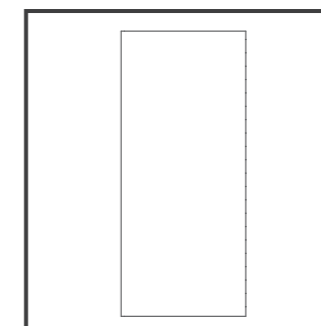

**Solid Sheet Roof**

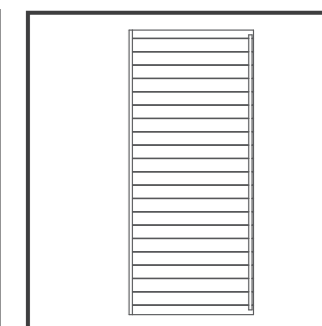

**T&G Roof**

**01OVLPP0705SDFW-V1** Pages 2 -6

**7x5 Overlap pent single door fixed window**

**01OVLPP0806SDFW-V1** Pages 7 -11

**8x6 Overlap pent single door fixed window**

**01OVLPP1006SDFW-V1** Pages 12 -16

**10x6 Overlap pent single door fixed window**

**BEFORE YOU START PLEASE READ INSTRUCTIONS CAREFULLY**

- Check the pack and make sure you have all the parts listed.
- When you are ready to start, make sure you have the right tools at hand (**not supplied**) including a Phillips screwdriver, Stanley knife, wood saw, step ladder and drill with 2mm bit.
- Ensure there is plenty of space and a clean dry area for assembly.

**TIMBER**

As with all natural materials, timber can be affected during various weather conditions. For the duration of heavy or extended periods of rain, swelling of the wood panels may occur. Warping of the wood may also occur during excessive dry spells due to an interior moisture loss. Unfortunately, these processes cannot be avoided but can be helped. It is suggested that the outdoor building is sprayed with water during extended periods of warm sunshine and sheltered as much as possible during rain or snow.

Our buildings are pre treated with a water based treatment\*\*; this only helps to protect the product during transit and for upto 3 months against mould. To validate your guarantee and ensure longevity of the product, it is ESSENTIAL the building is treated with a wood preserver within the first three months of assembly and thereafter in accordance with the manufactures recommendations. Care must be taken to ensure the product is placed on a suitable base.

**BUILDING A BASE**

When thinking about where the building and base is going to be constructed: Ensure that there will be access to all sides for maintenance work and annual treatment.

Ensure the base is level and is built on firm ground, to prevent distortion. Refer to diagrams for the base dimensions, The base should be slightly smaller than the external measurement of the building, i.e. The cladding should overlap the base, creating a run off for water. It is also recommended that the floor be at least 25mm above the surrounding ground level to avoid flooding.

**TYPES OF BASE**

- Concrete 75mm laid on top of 75mm hard-core.
- Slabs laid on 50mm of sharp sand.

**Whilst all products manufactured are made to the highest standards of Safety and in the case of childrens products independently tested to EN71 level, we cannot accept responsibility for your safety whilst erecting or using this product.**



x2

All building's should be erected by two adults



2mm Drill bit

For ease of assembly, it is advisable to pilot drill all screw holes and ensure all screw heads are countersunk.



Winter = High Moisture = Expansion  
Summer = Low Moisture = Contraction



**CAUTION**

Every effort has been made during the manufacturing process to eliminate the prospect of splinters on rough surfaces of the timber. You are strongly advised to wear gloves when working with or handling rough sawn timber.

**For Assistance Please Contact Customer Care on**

**01636 880514**

**\*\*Protim Fentex E5\*\***

**Biocidal Product Regulation (EU 528/2012)** Article 58 Information  
Protim Fentex E2 preserved wood is a "treated article" which incorporates biocidal products. Wood correctly preserved with Protim Fentex E2 is protected against mould in storage.  
Contains: IPBC (3-iodo-2-propynyl-N-butyl carbamate) and propiconazole.

Wear gloves when handling freshly treated wood.  
Avoid breathing dust when cutting treated or untreated wood.  
Dispose of off-cuts responsibly – do not burn.

### Overall Dimensions:

Length = 1553mm  
Width = 2134mm  
Height = 2022mm

### Base Dimensions:

Length = 2066mm  
Width = 1456mm

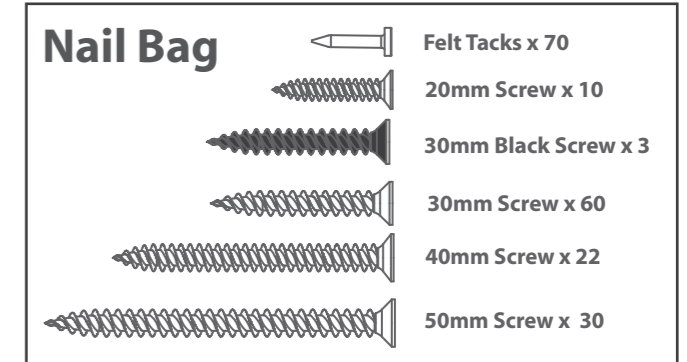
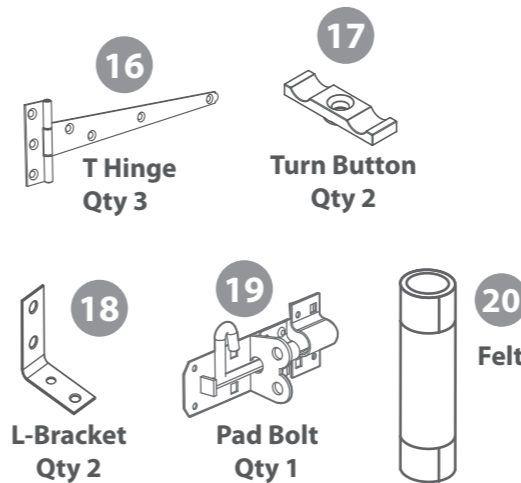
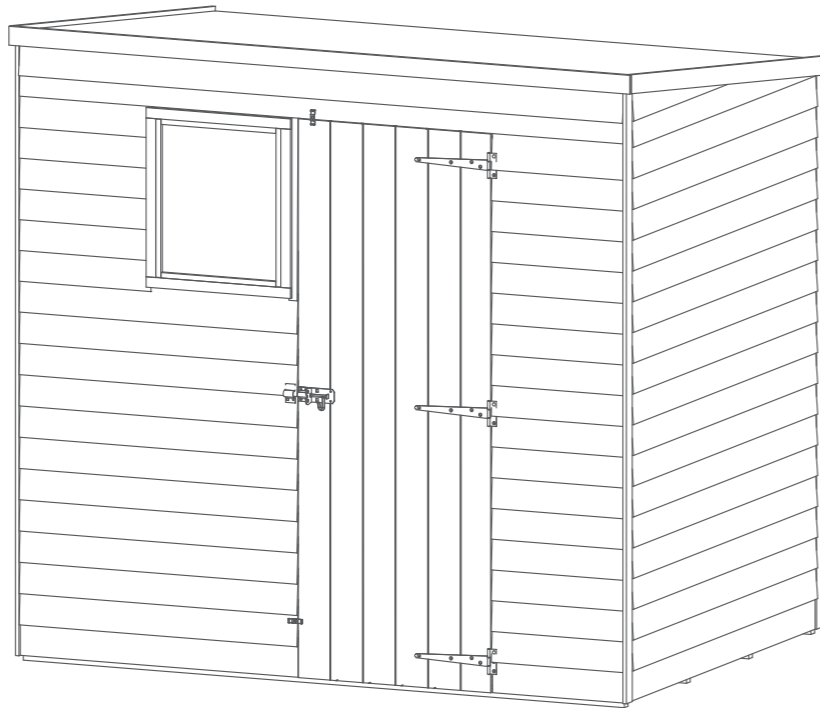

### Pre Assembly

Remove transportation blocks from the bottom of each panel before beginning assembly. Each Panel should have two

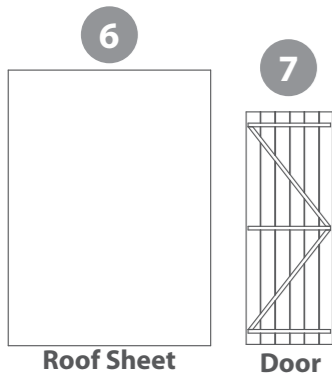
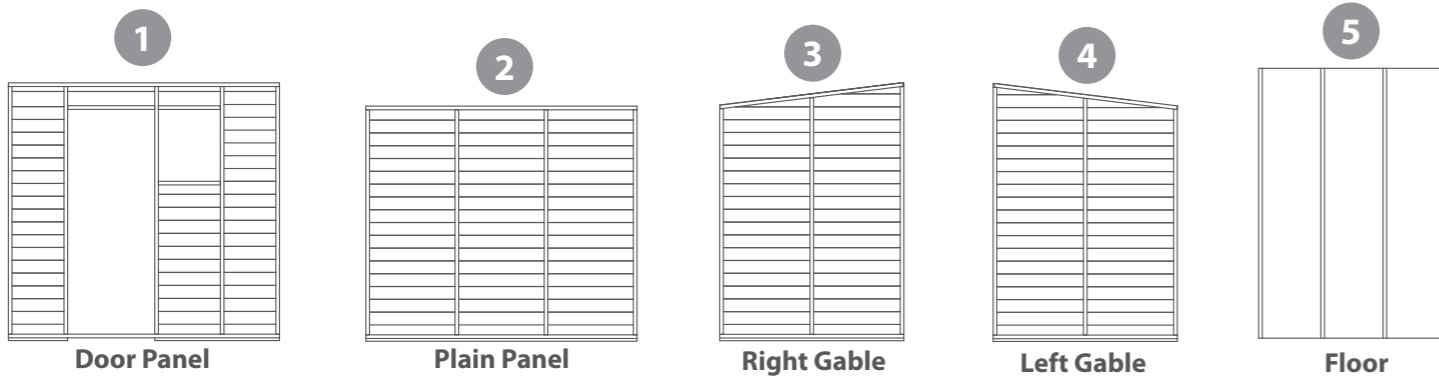
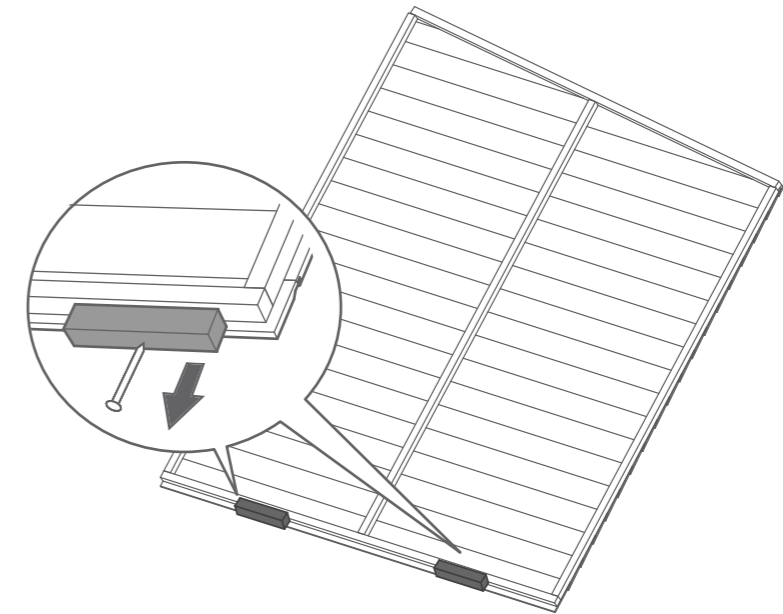

- 8 Ridge Bar - 2020mm Qty 1
- 9 Eaves Frame - 2110mm Qty 1
- 10 Door Block- 140mm Qty 1
- 11 Front Fascia- 2134mm Qty 1
- 12 Side Fascia- 1553mm Qty 2
- 13 Front Cover Trims- 1975mm Qty 2
- 14 Back Cover Trims- 1800mm Qty 2
- 15 Door Strip - 1720mm Qty 2

Fix the T Hinges onto the door and door frame as shown. Ensure that the screws go through the cladding and into the framing behind.

21x30mm screws

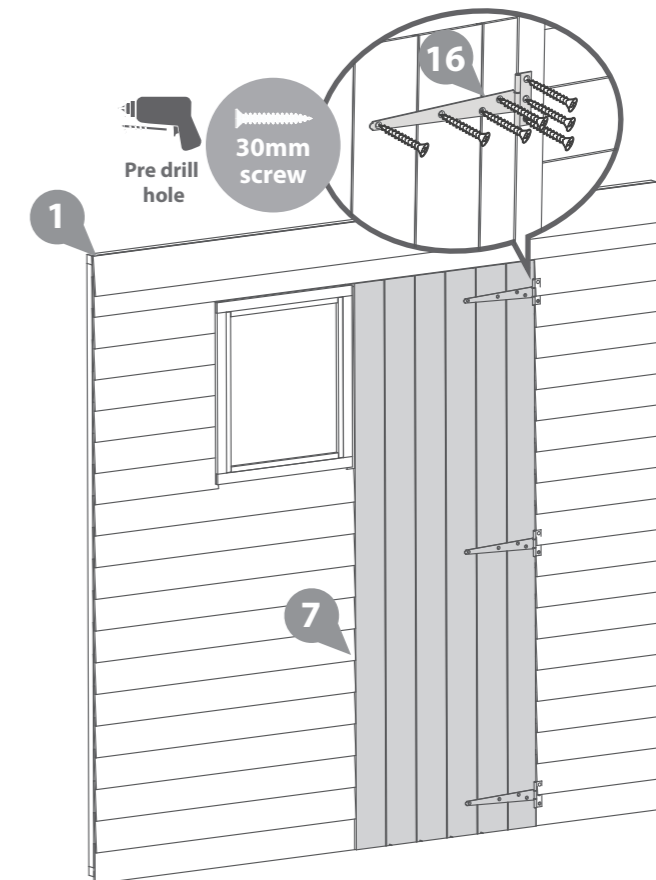

## Step 1

Place the floor on a firm and level base, ensure the base has suitable drainage free from areas where standing water can collect. See the front page for base requirements.

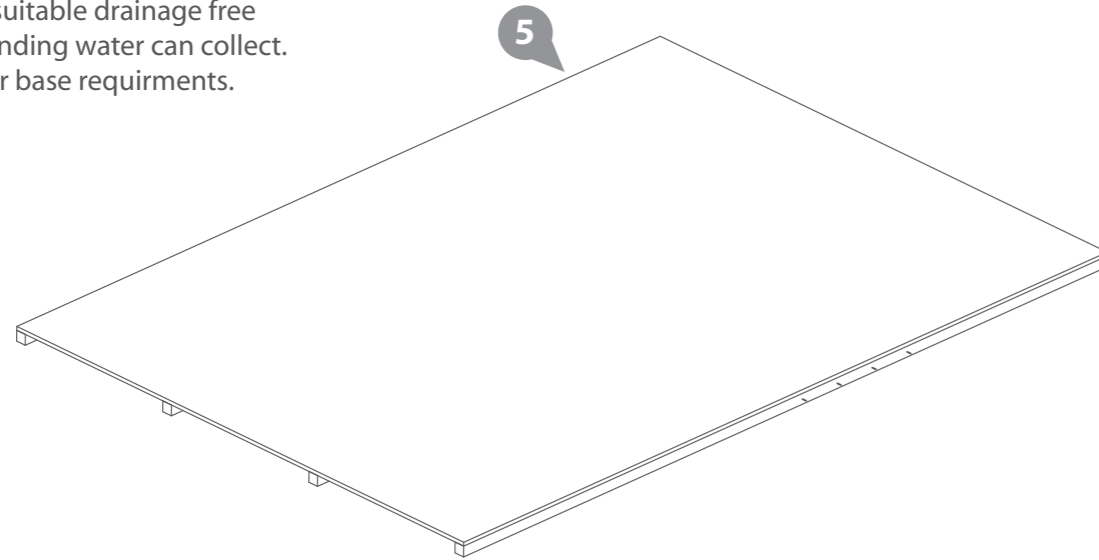

## Step 2

Fix the corners with 50mm screws as shown in diagram.

Do not secure the building to the floor until the roof is fitted.

Position the panels so there is equal spacing between the floor and cladding on all 4 sides

3x50mm Screws



50mm screw

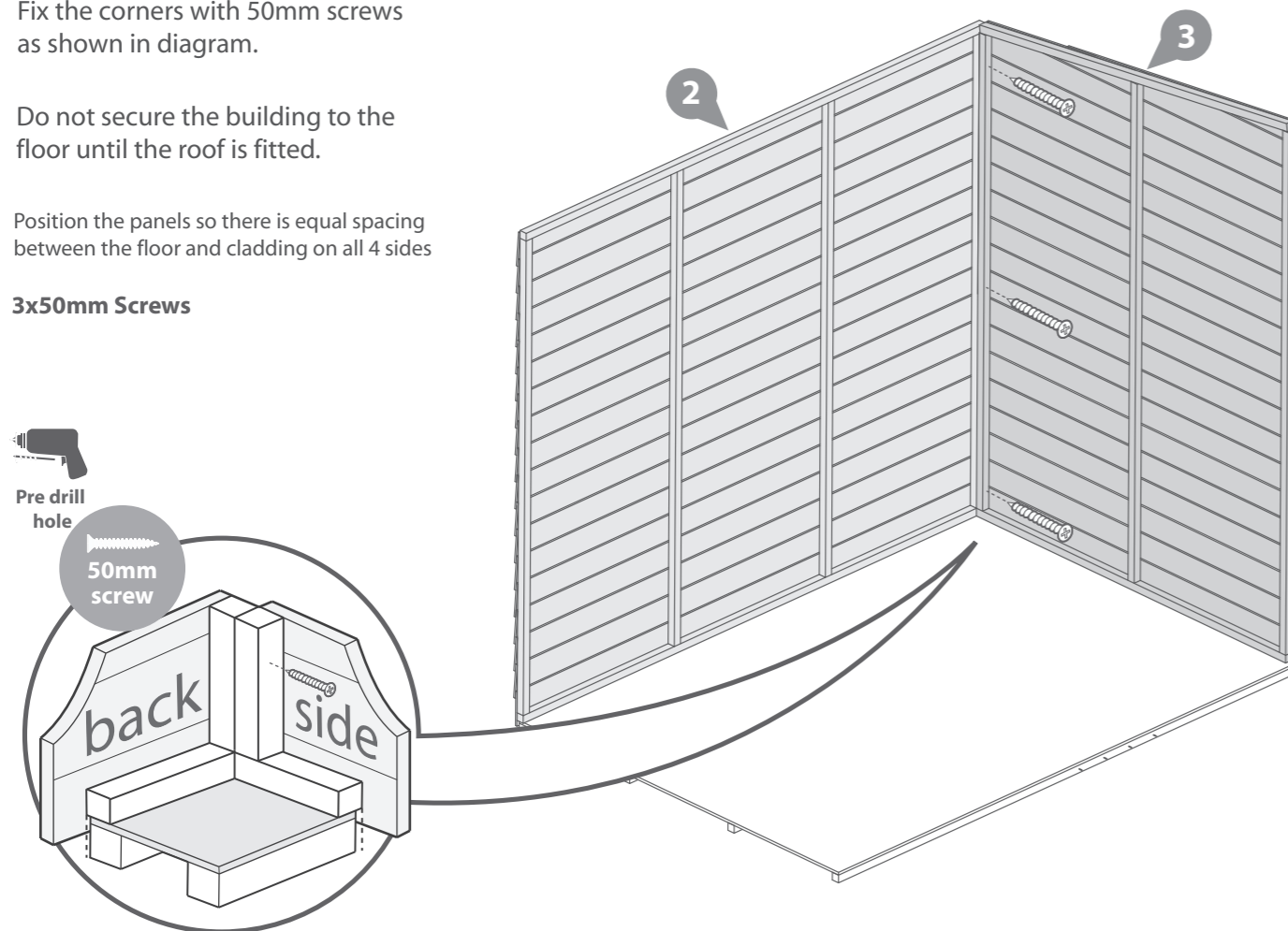

## Step 3

Fix the corners with 50mm screws as shown in diagram.

9x50mm Screws



Pre drill hole

50mm screw

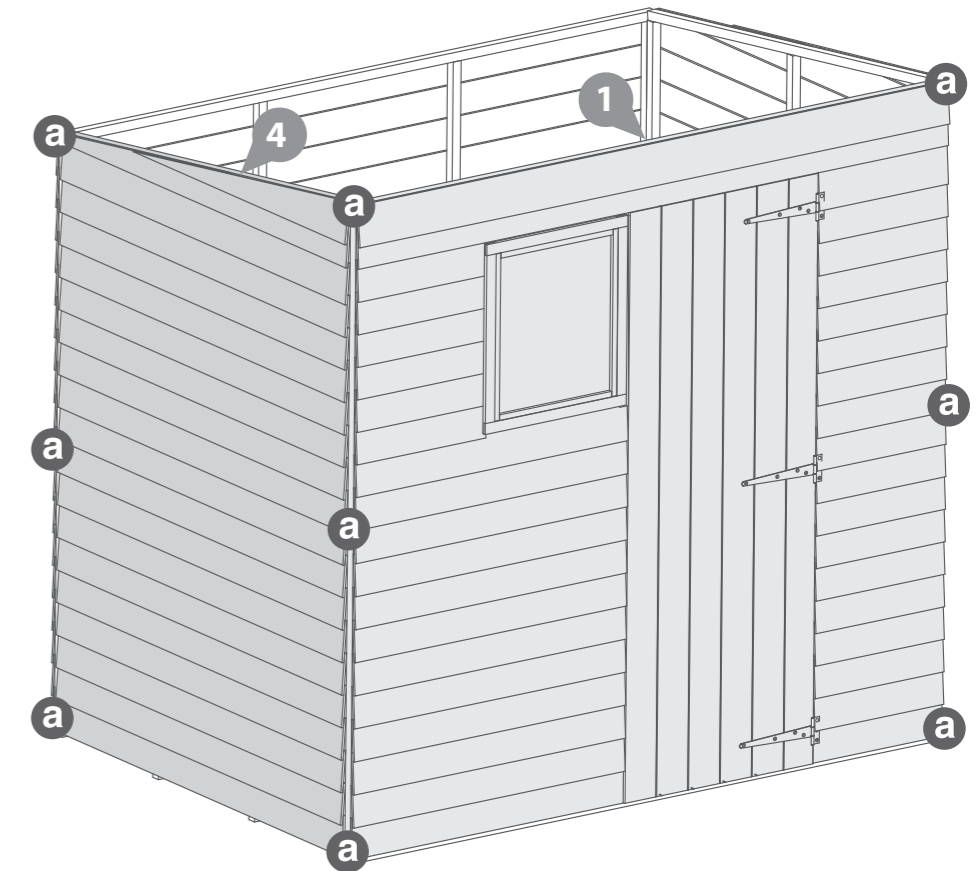
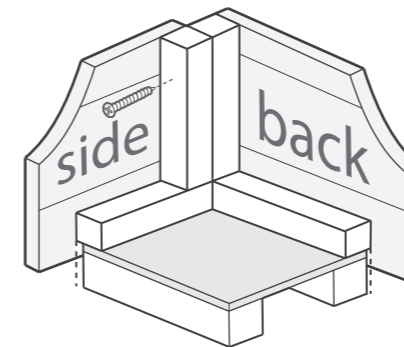

## Step 4

Place the ridge bar in between the two gables. Ensure the top corner of the ridge bar sit flush with the top of the gable. Fix the ridge bar to the gable using one L bracket for each end.

Fix with 4x20mm screws each

8x20mm Screws



Pre drill hole

20mm screw

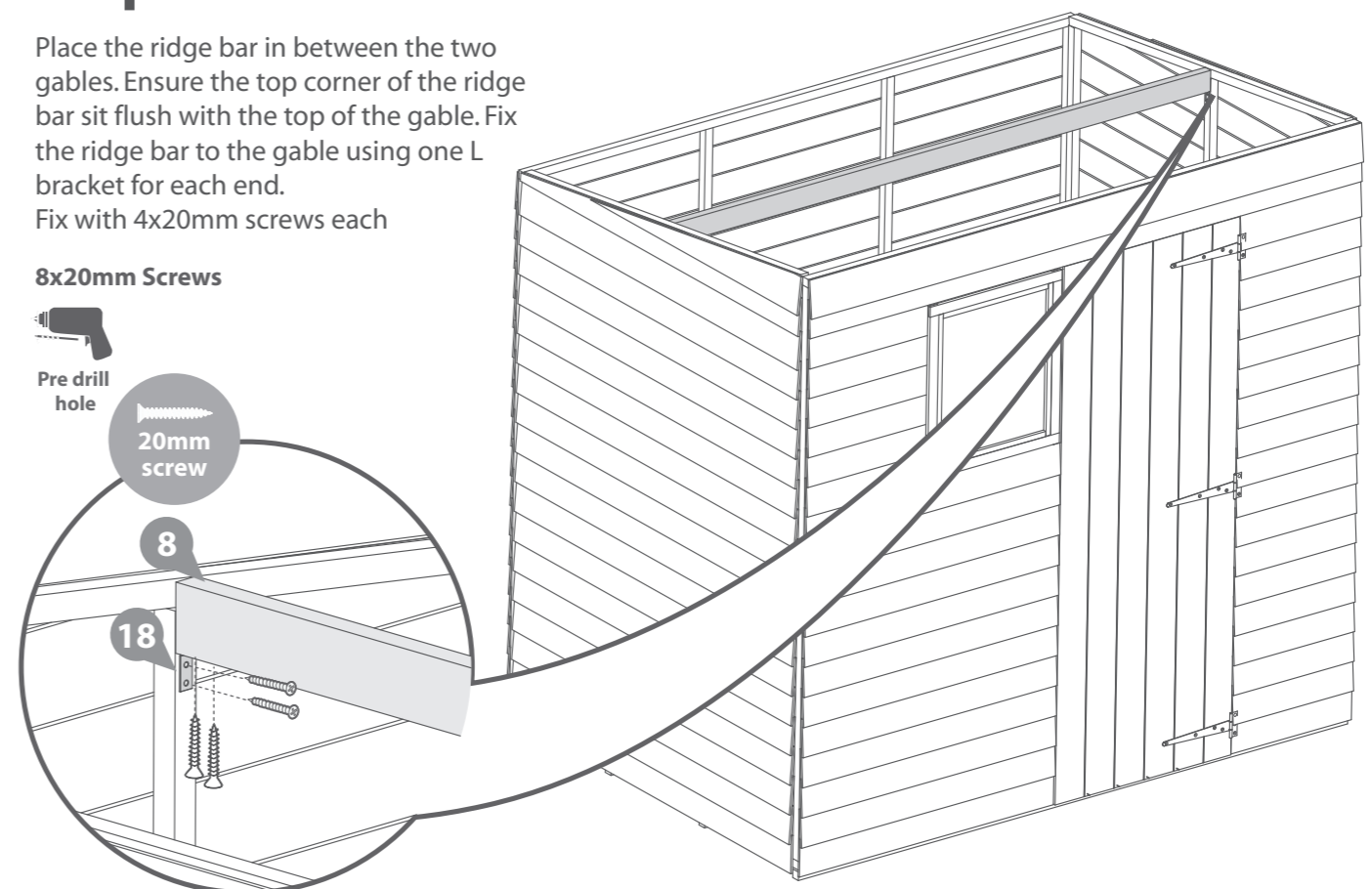

### Step 5

**a** Fix the eaves frame to the roof sheet using 4x30mm screws for each sheet.  
**4x30mm Screws**

**b** Place the roof sheet onto the building and fix in place with 40mm screws.  
**10x40mm Screws**

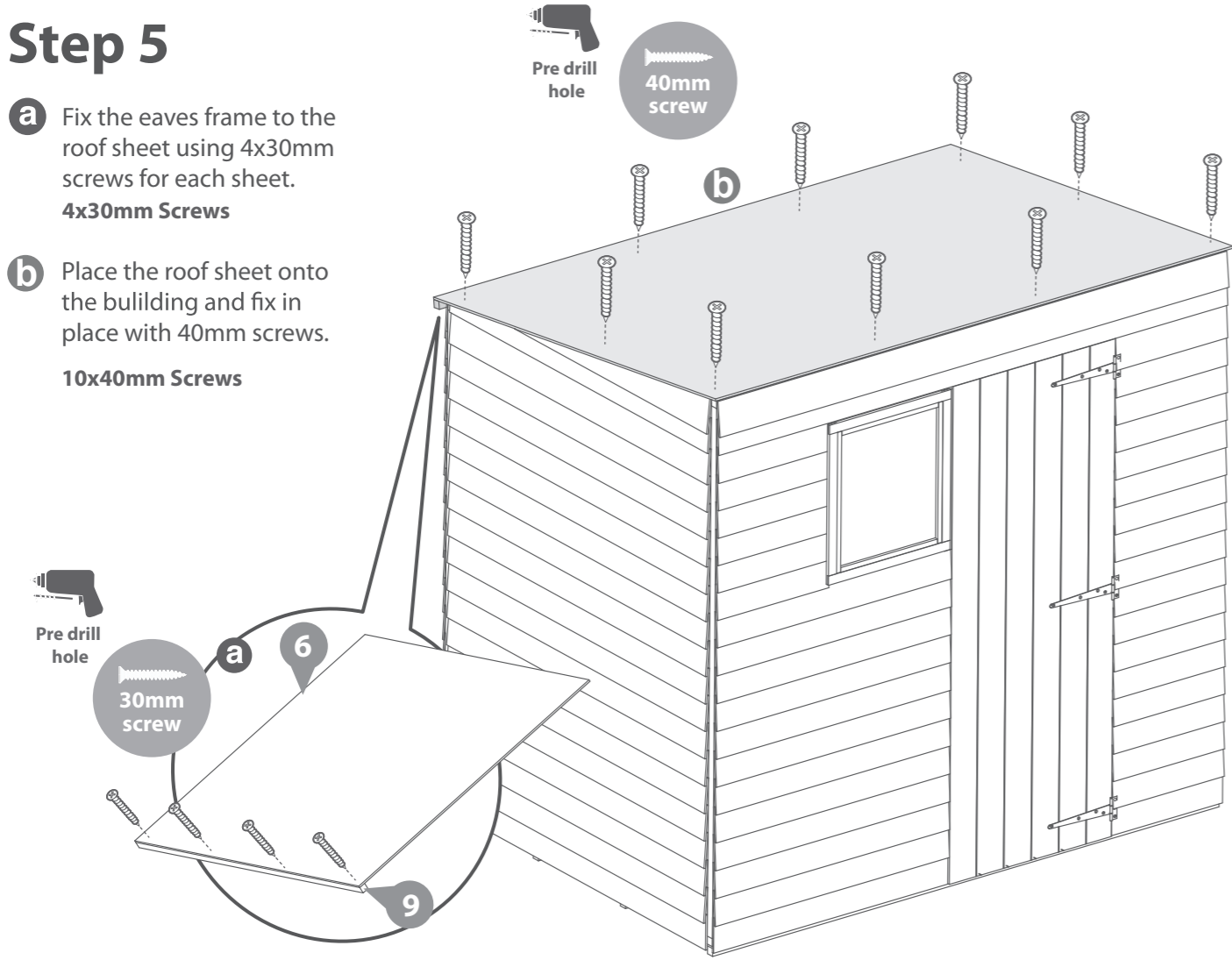

### Step 7

Cut the felt into 2x 2210mm long sheets and lay onto roof as shown in diagram ensuring there is overhang around the sides.

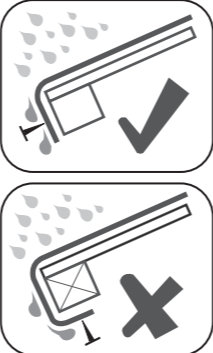

70x felt tacks

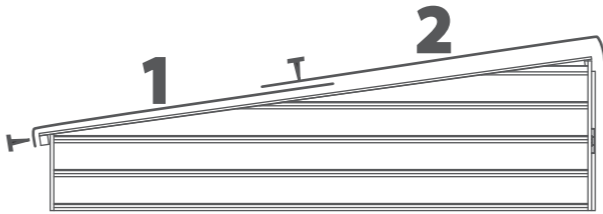
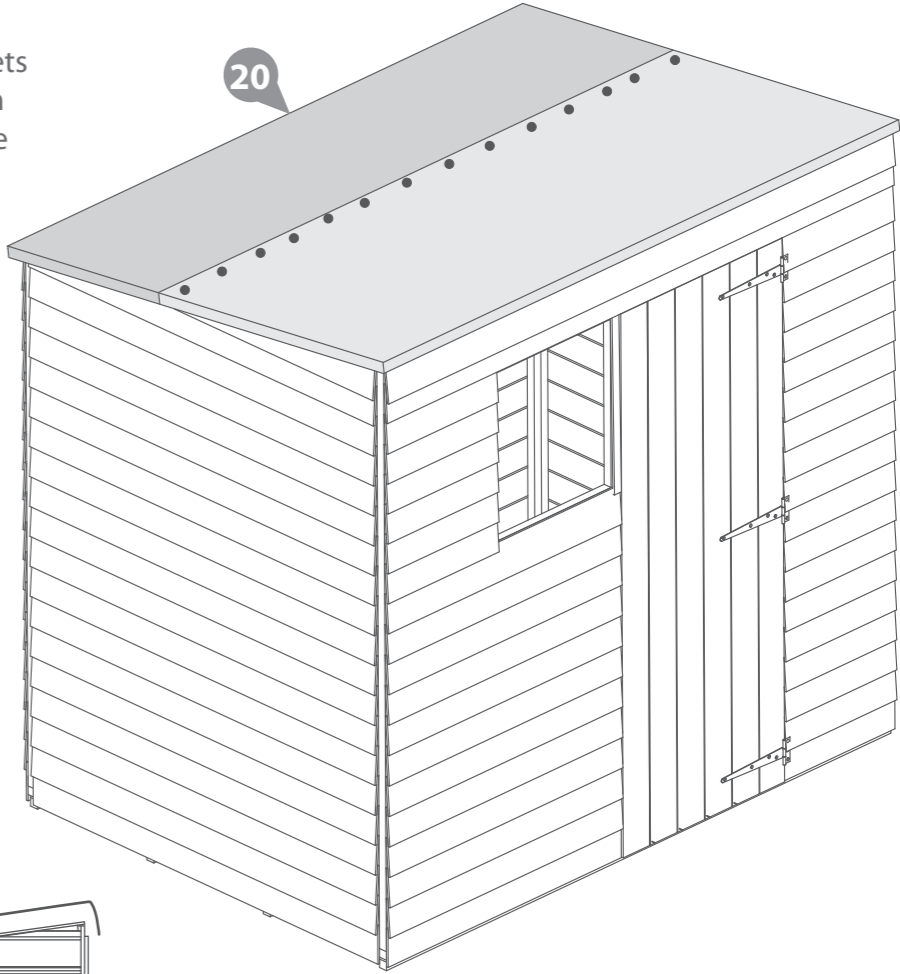

### Step 6

Once the roof is fixed attach the building to the floor with 50 mm screws.

**16x 50mm Screws**

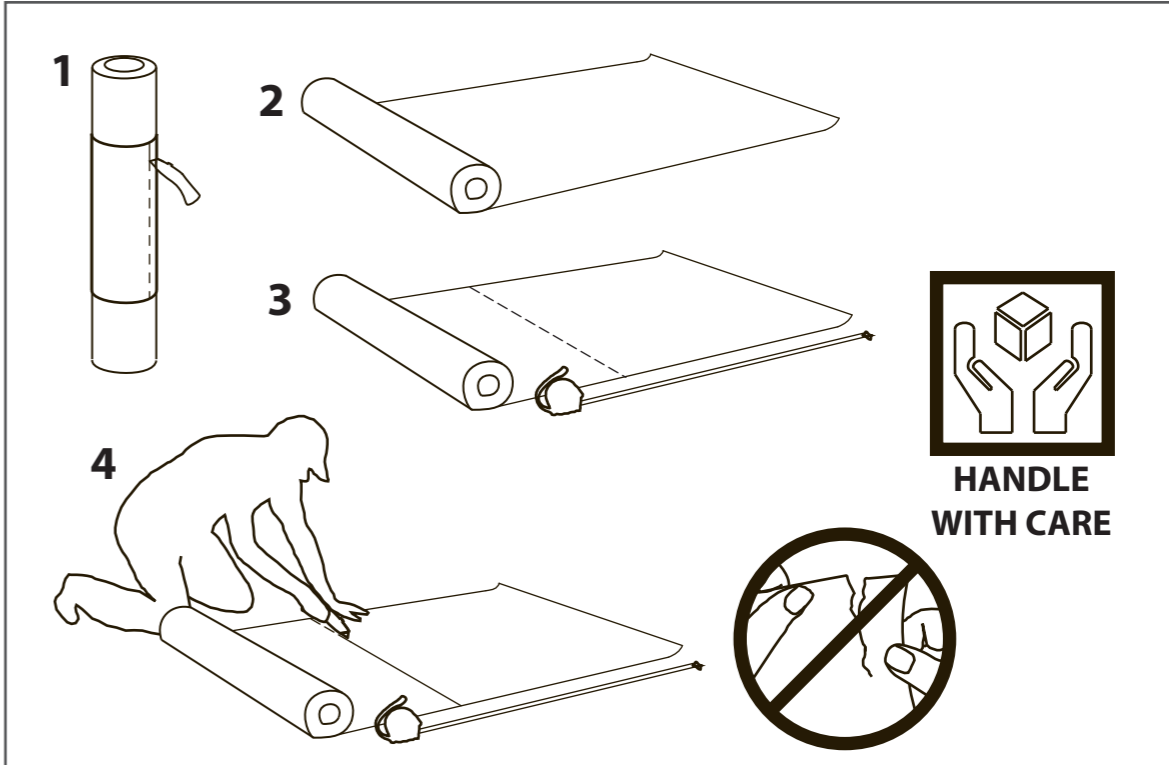
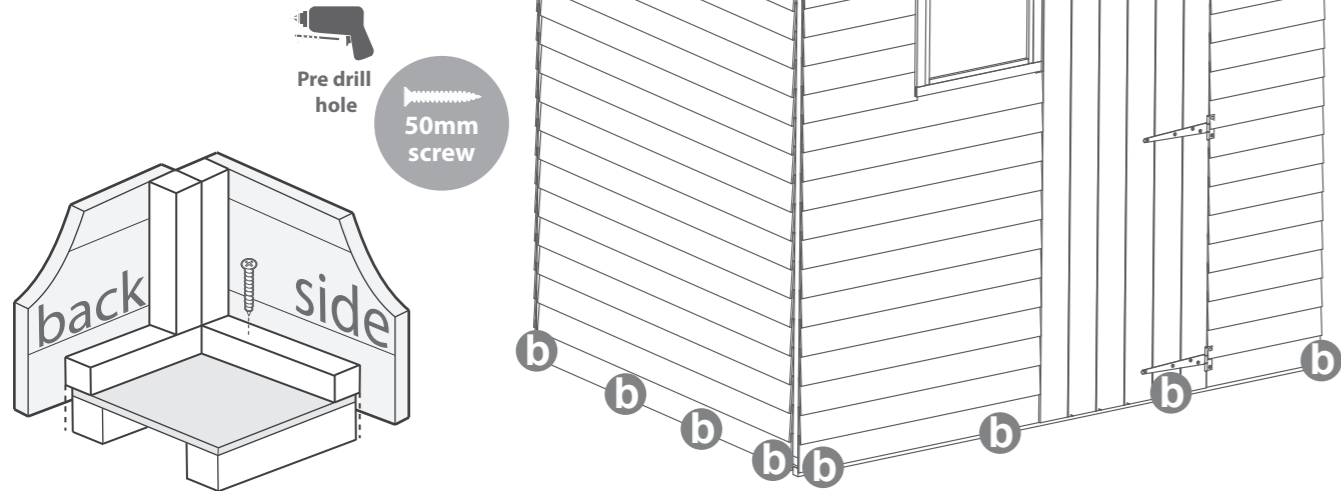

## Step 8

Fit the Cover Trims to the left and right of the building as shown in the illustration using 30mm screws. Trim the length of the cover trims to the required size before fitting if necessary. Pre drill to avoid splitting.

**12x30mm Screws**

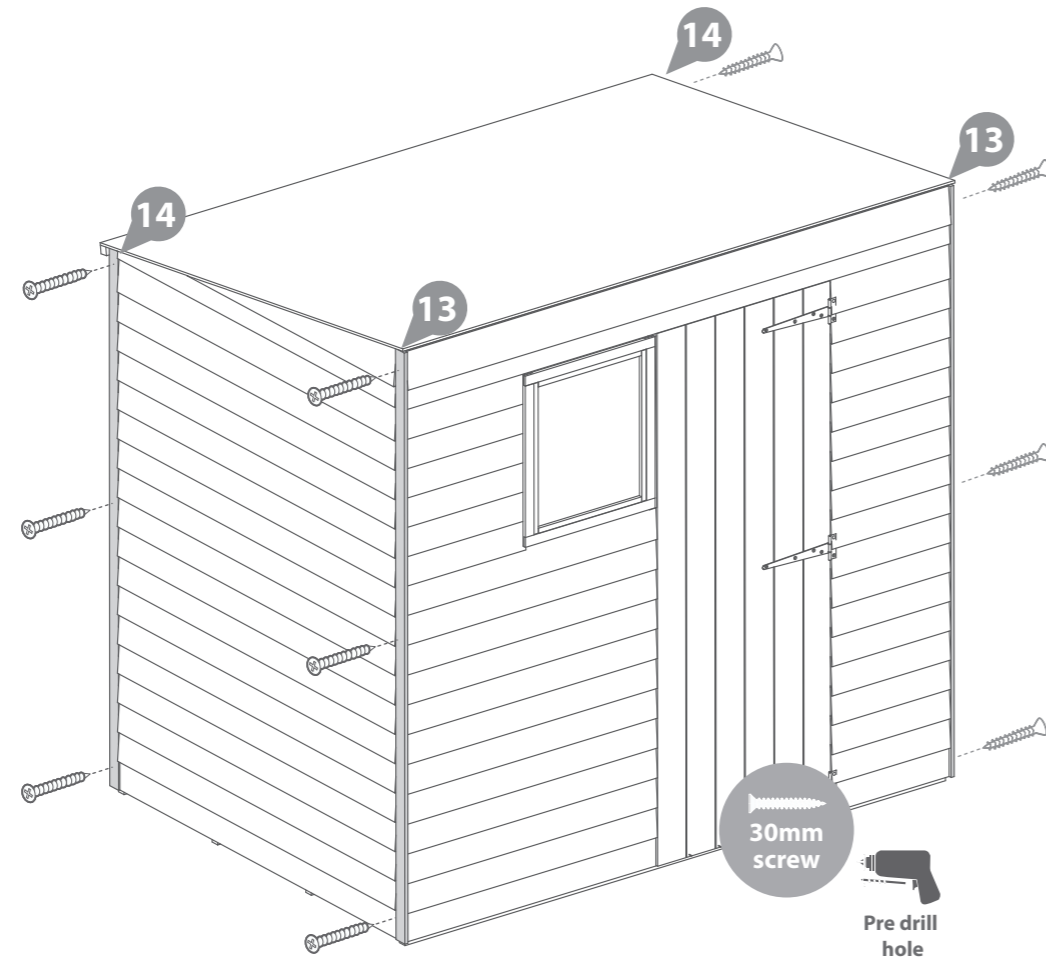
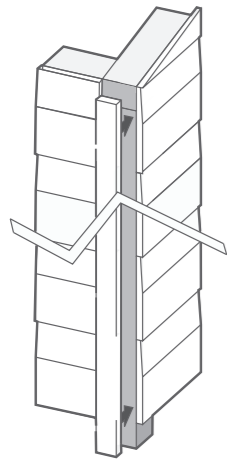

## Step 9

Attach the fascias to the roof leaving a slight overhang at the top.

Fit the fascias to the roof over the felt and secure in place with 40mm screws as shown. Pre drill to avoid splitting.

**10x40mm Screws**

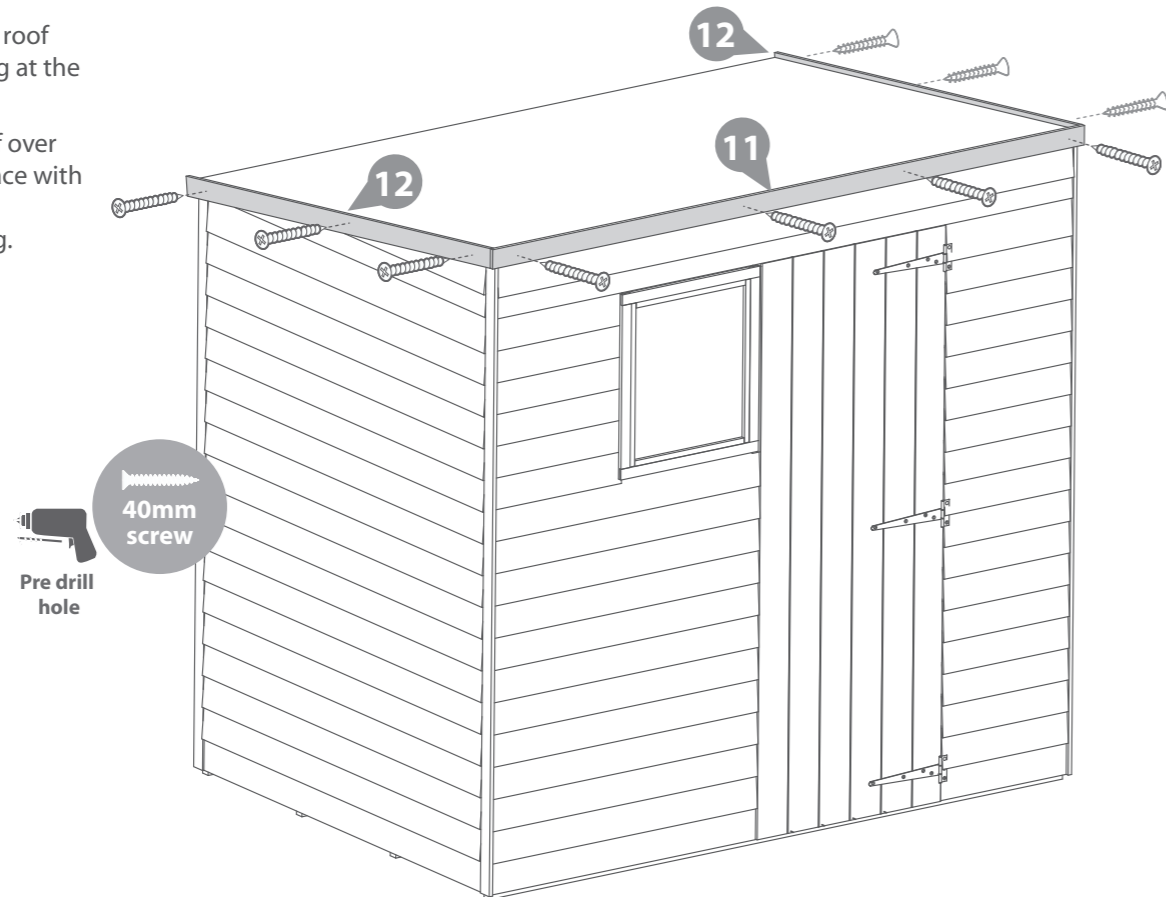

## Step 10

Use 4x30mm screws to fix each beading strip onto the door panel. Ensure that the screw is parallel with the strip when fixing the strip to the door panel as shown in the close up view.

Line up the door block as shown in the illustration. Then fix with 2x30mm screws by screwing through the outside of the door into the block.

**10x30mm Screws**

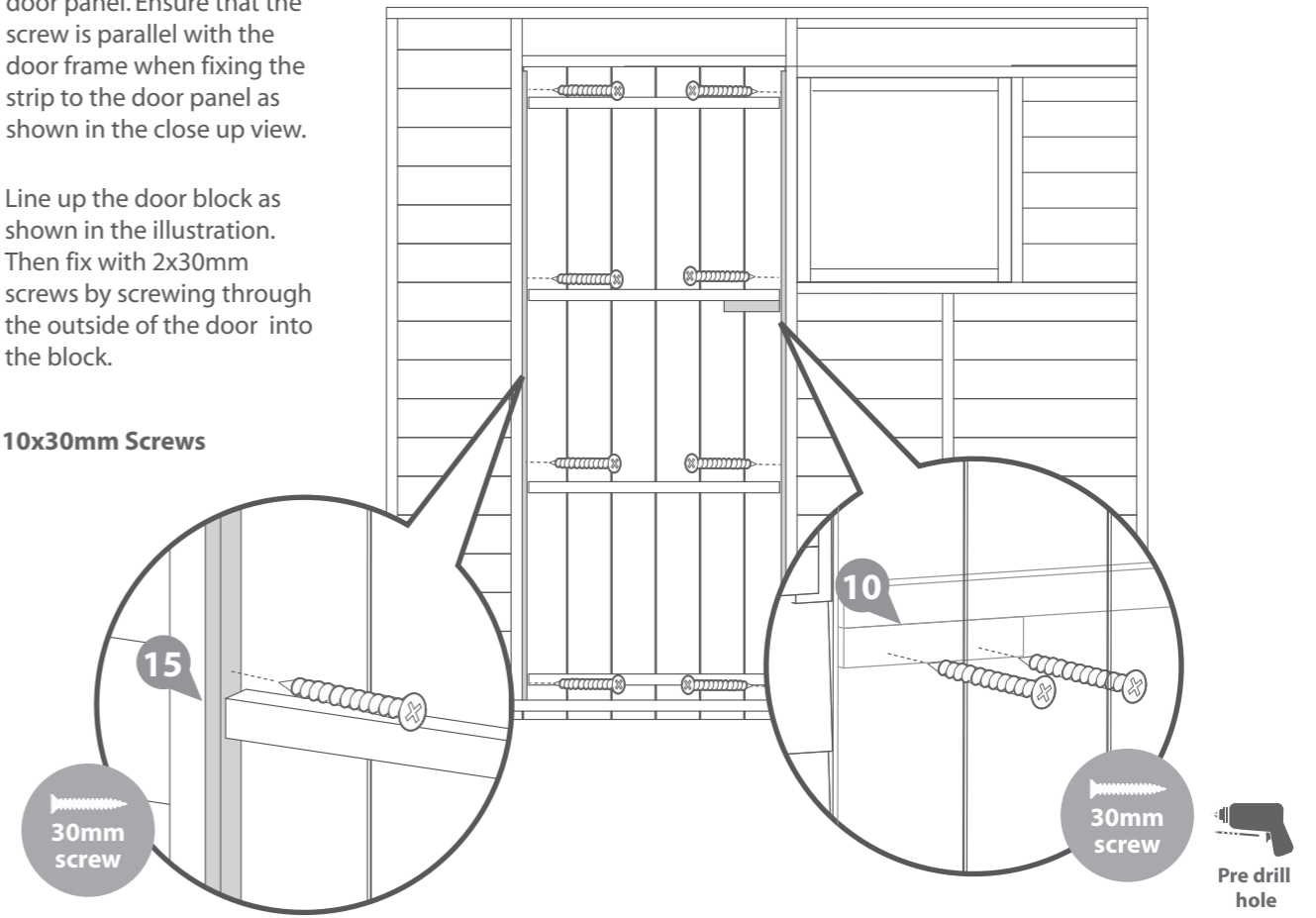

## Step 12

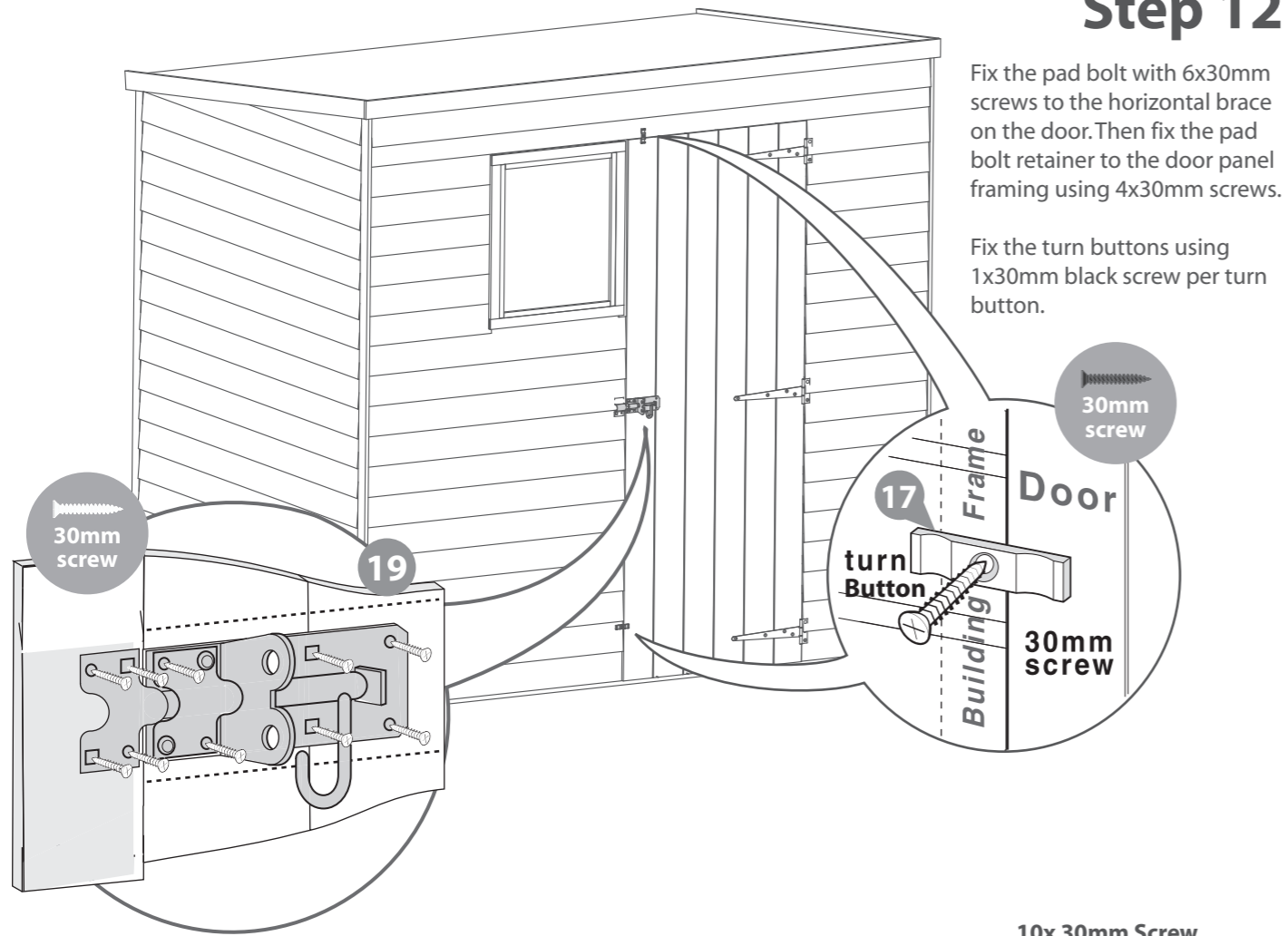

Fix the pad bolt with 6x30mm screws to the horizontal brace on the door. Then fix the pad bolt retainer to the door panel framing using 4x30mm screws.

Fix the turn buttons using 1x30mm black screw per turn button.

10x 30mm Screw  
2x 30mm Black Screw



It is **ESSENTIAL** that you apply wood treatment immediately after the building has been assembled.

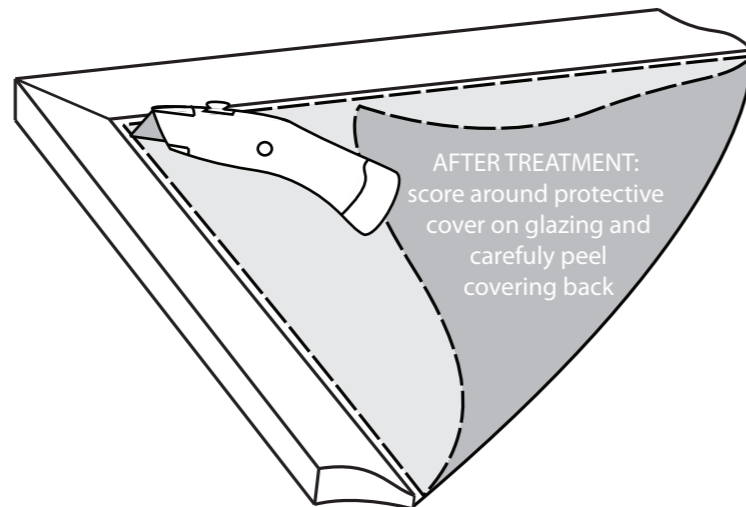

AFTER TREATMENT:  
score around protective cover on glazing and carefully peel covering back

### Overall Dimensions:

Length = 1871mm  
Width = 2408mm  
Height = 2057mm

### Base Dimensions:

Length = 1753mm  
Width = 2350mm

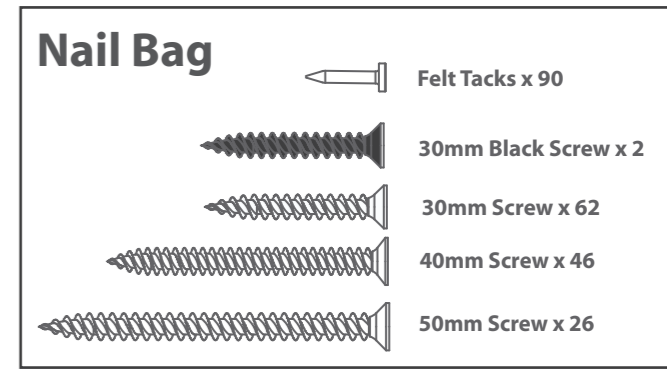
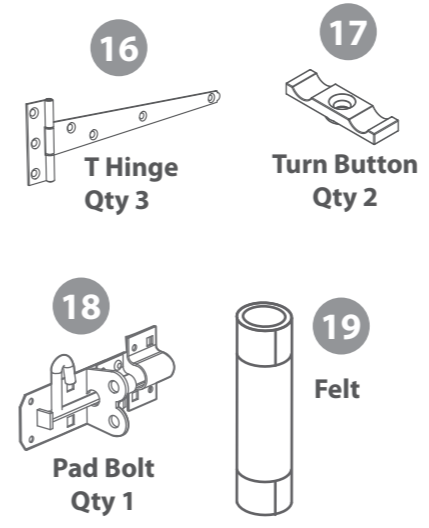
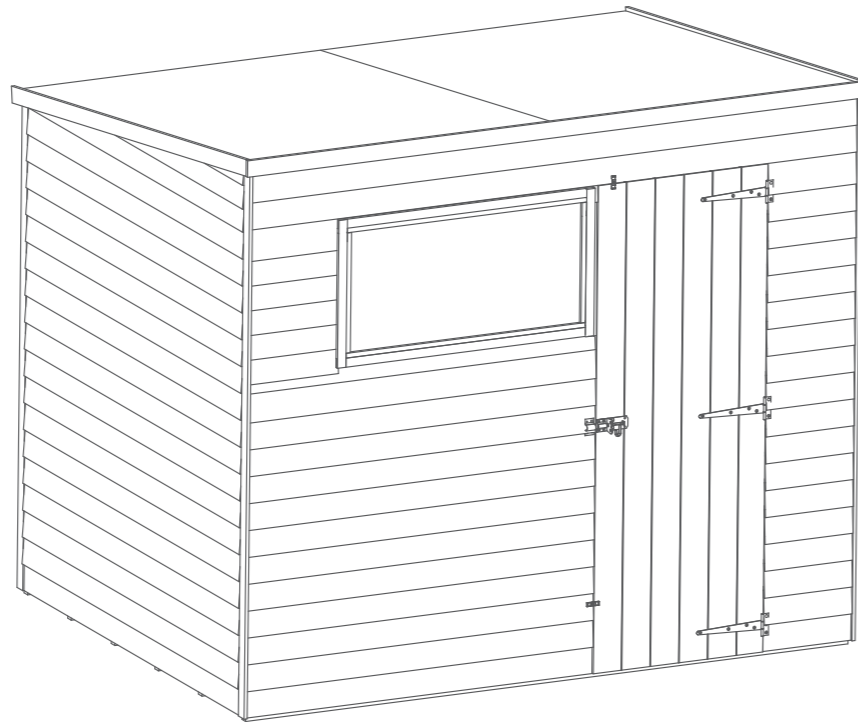

## Building content

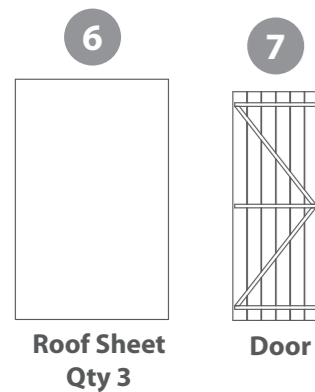
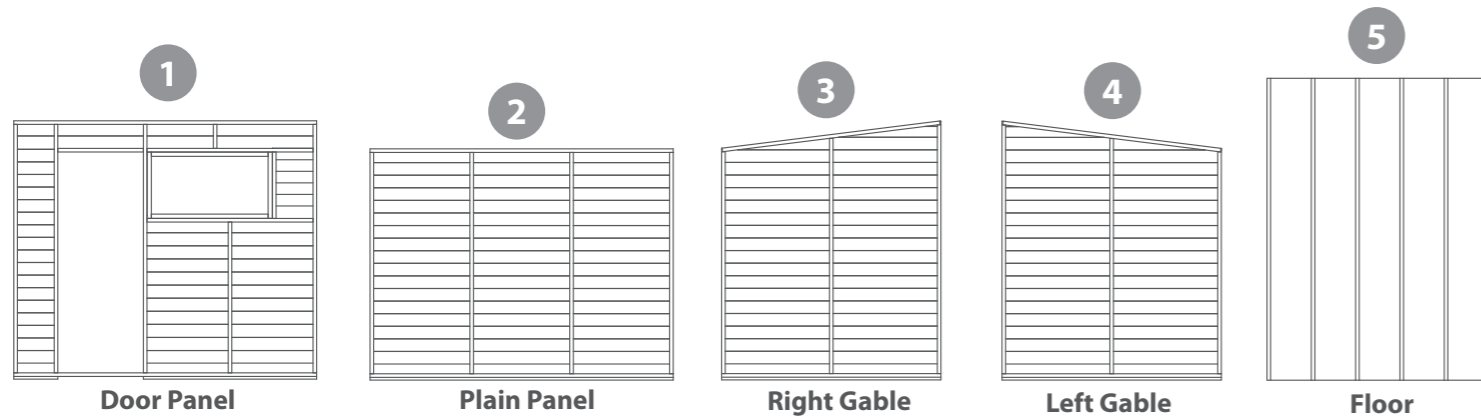

- 8 Roof Frame - 1715mm Qty 2
- 9 Eaves Frame - 795mm Qty 3
- 10 Door Block- 140mm Qty 1
- 11 Front Fascia- 2414mm Qty 1
- 12 Side Fascia- 1873mm Qty 2
- 13 Front Cover Trims- 2020mm Qty 2
- 14 Back Cover Trims- 1800mm Qty 2
- 15 Door Strip - 1720mm Qty 2

## Pre Assembly

Remove transportation blocks from the bottom of each panel before beginning assembly. Each Panel should have two

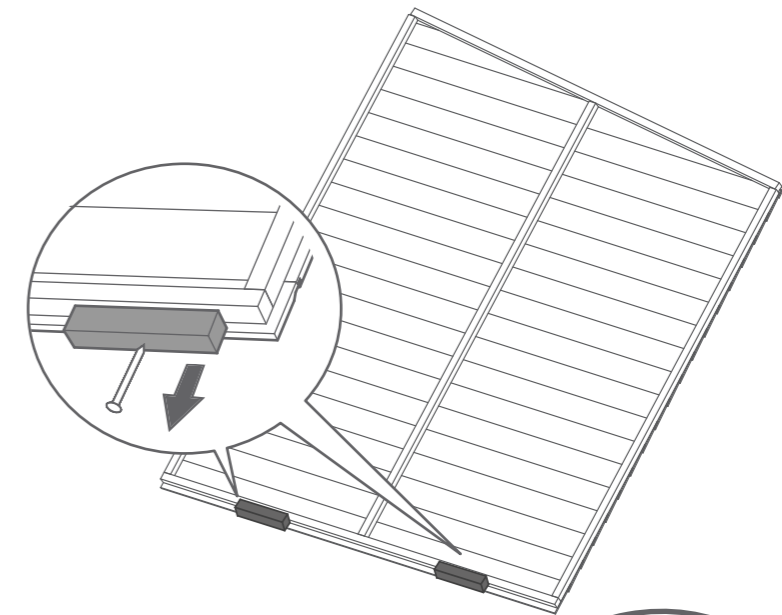

Fix the T Hinges onto the door and door frame as shown. Ensure that the screws go through the cladding and into the framing behind.

21x30mm screws

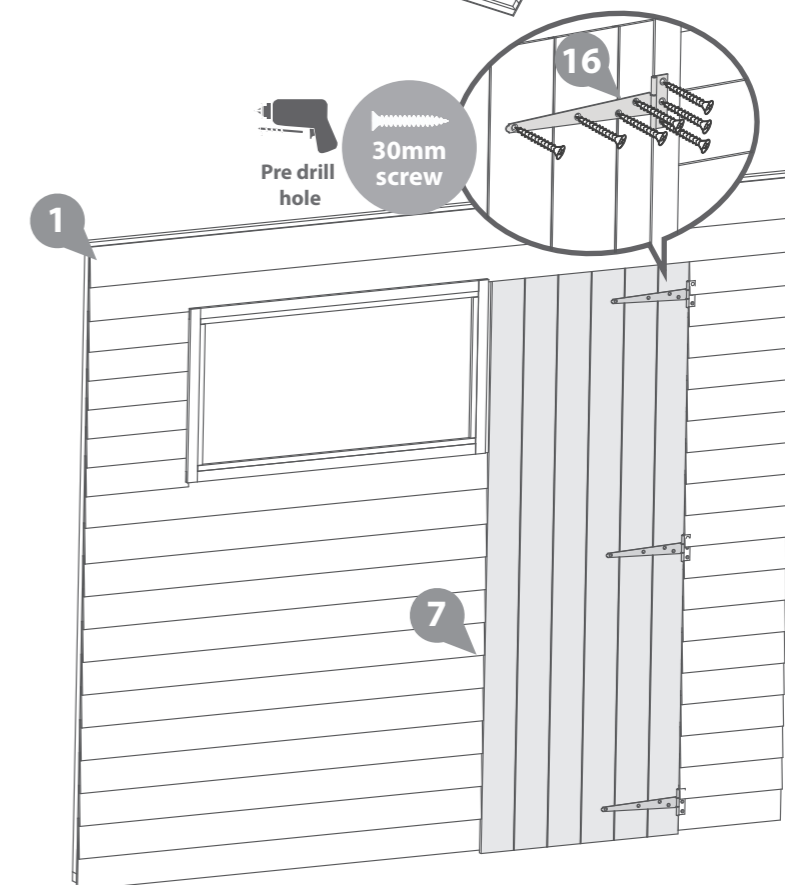

## Step 1

Place the floor on a firm and level base, ensure the base has suitable drainage free from areas where standing water can collect. See the front page for base requirements.

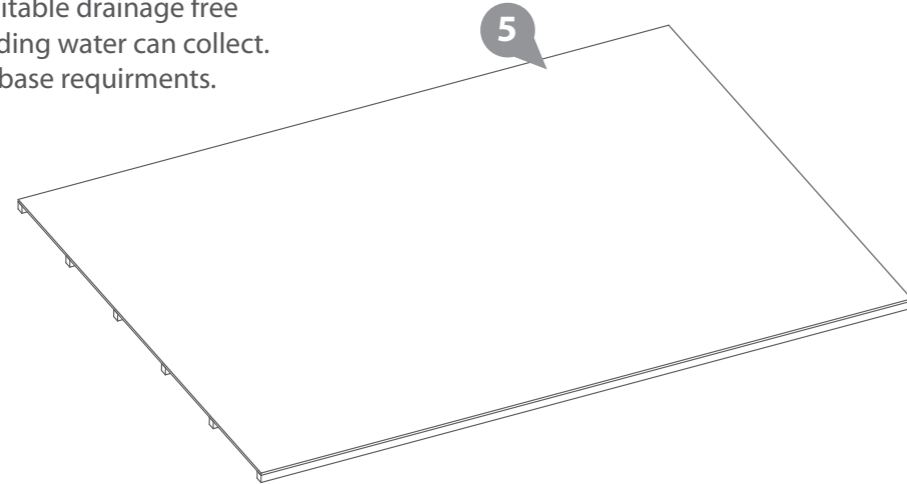

## Step 2

Fix the corners with 50mm screws as shown in diagram.

Do not secure the building to the floor until the roof is fitted.

Position the panels so there is equal spacing between the floor and cladding on all 4 sides

3x50mm Screws

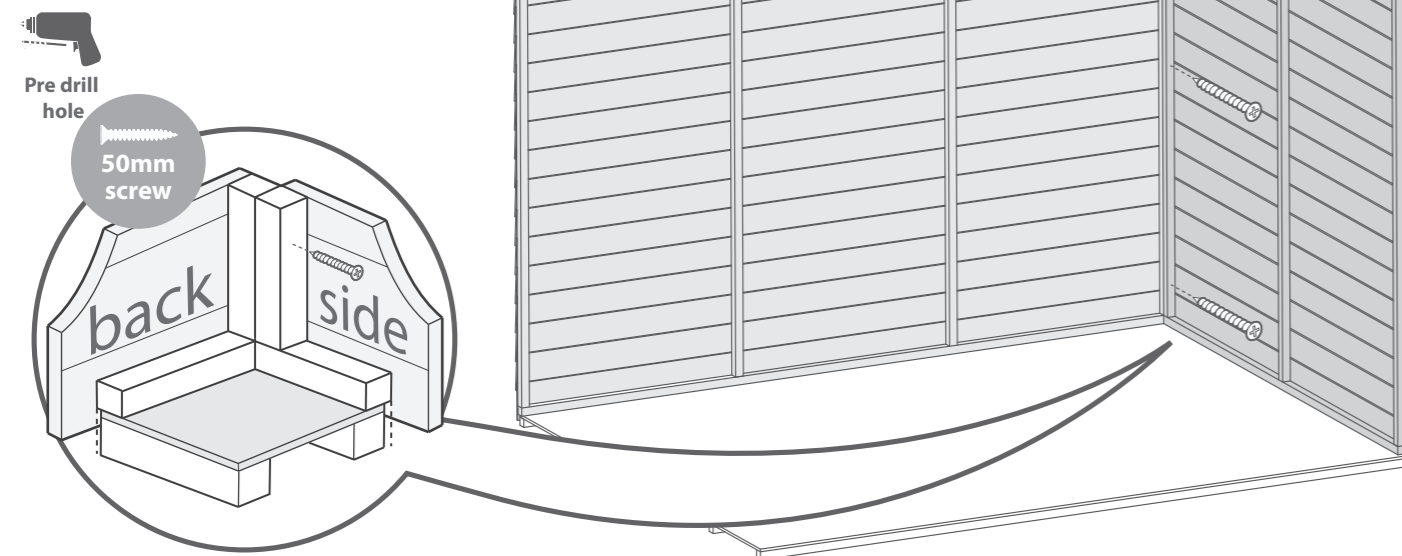

## Step 3

Fix the corners with 50mm screws as shown in diagram.

9x50mm Screws

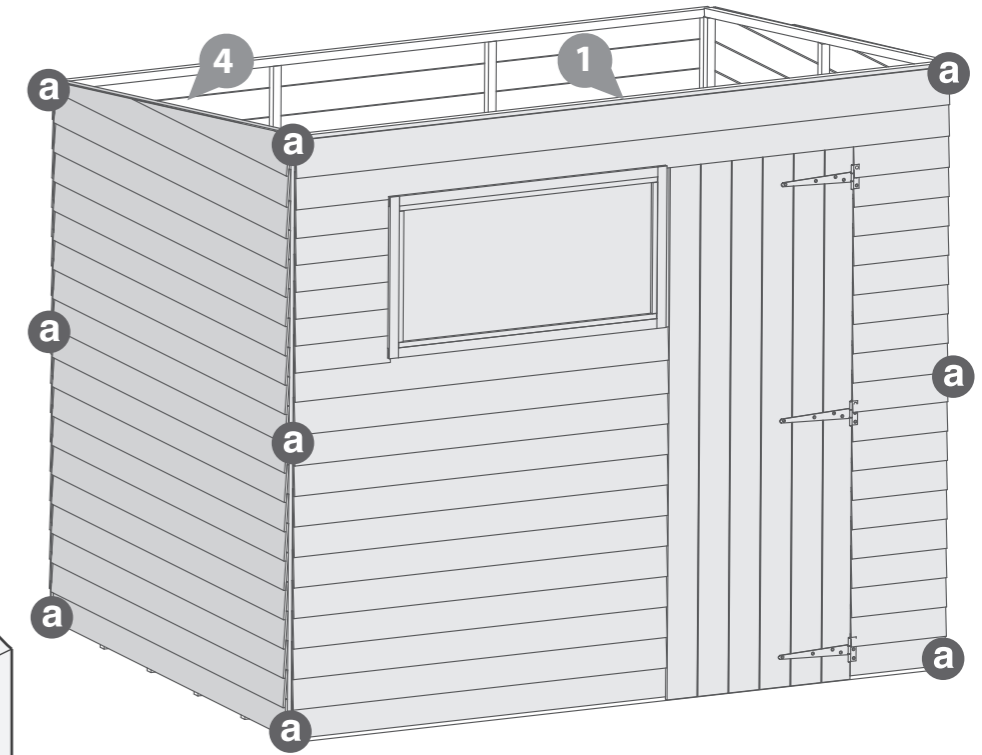
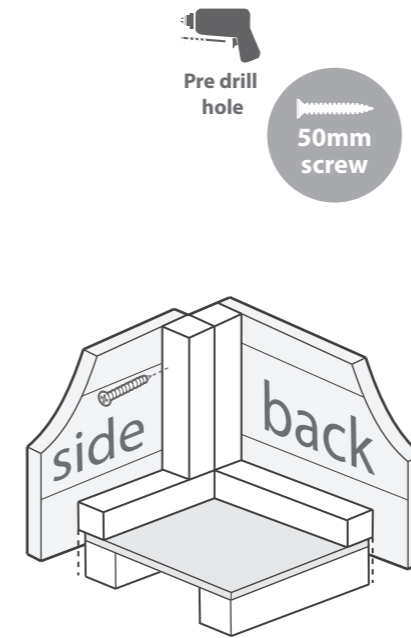

## Step 4

Position the two roof frame's between the front and back of the building centralised between the two gables. Fix in place using a 50mm screws screwing through the outside of the building into the roof frame.

4x50mm Screws

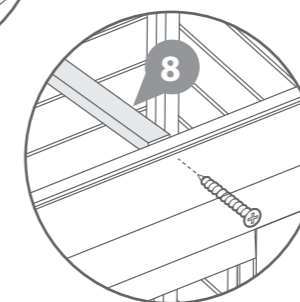
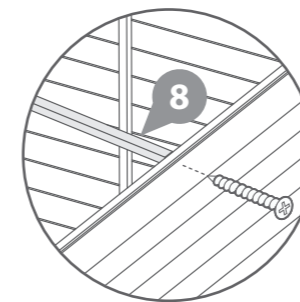

ENSURE SUPPORT BARS ARE MANUALLY SUPPORTED UNTIL FIXED AT BOTH ENDS

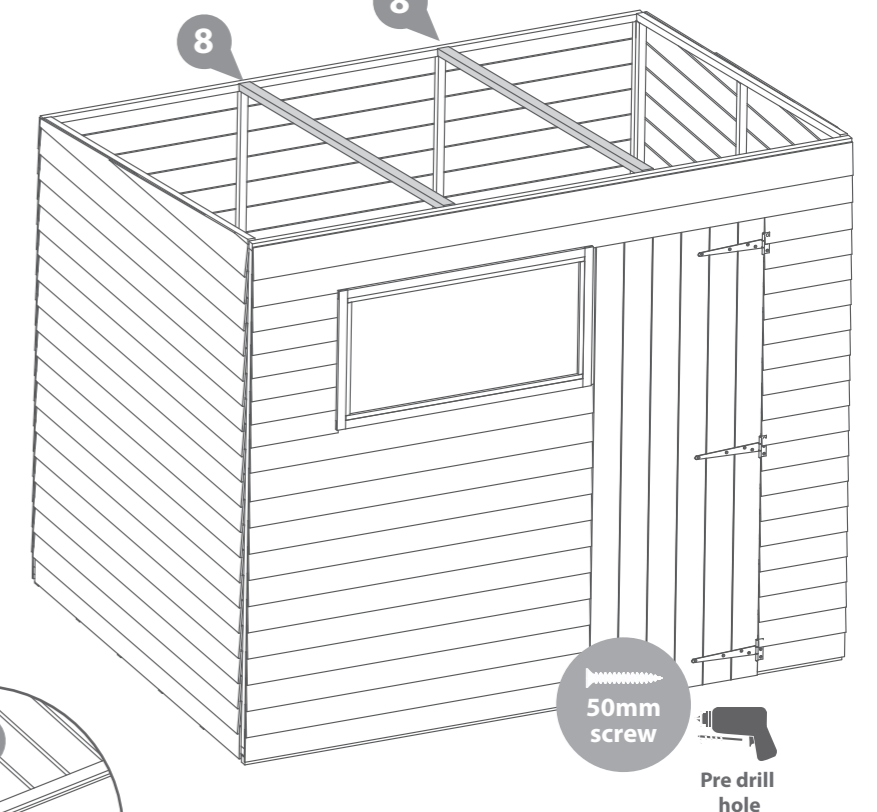



### Step 5

**a** Fix the eaves frame to the roof sheet using 4x30mm screws for each sheet.  
**8x30mm Screws**

**b** Place the two roof sheets onto the building, centralise them over the roof frames and make sure they finish flush with the front of the building. Fix in place with 40mm screws.

**36x40mm Screws**

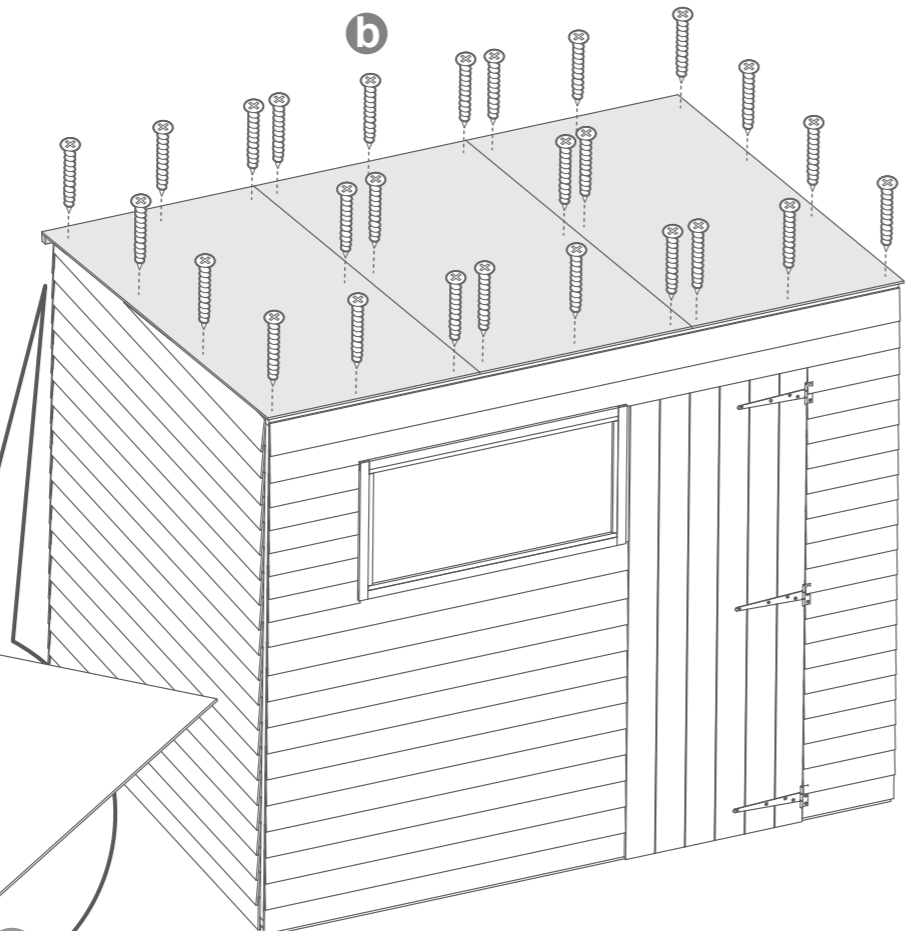
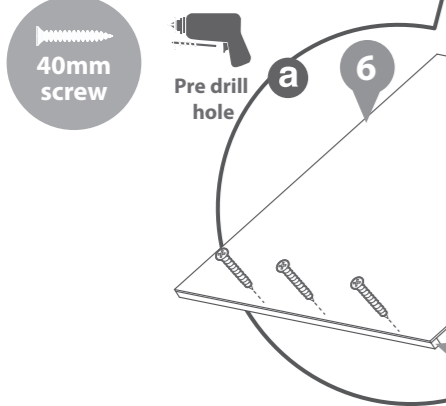

### Step 6

**b** Once the roof is fixed attach the building to the floor with 50 mm screws.

**18x 50mm Screws**

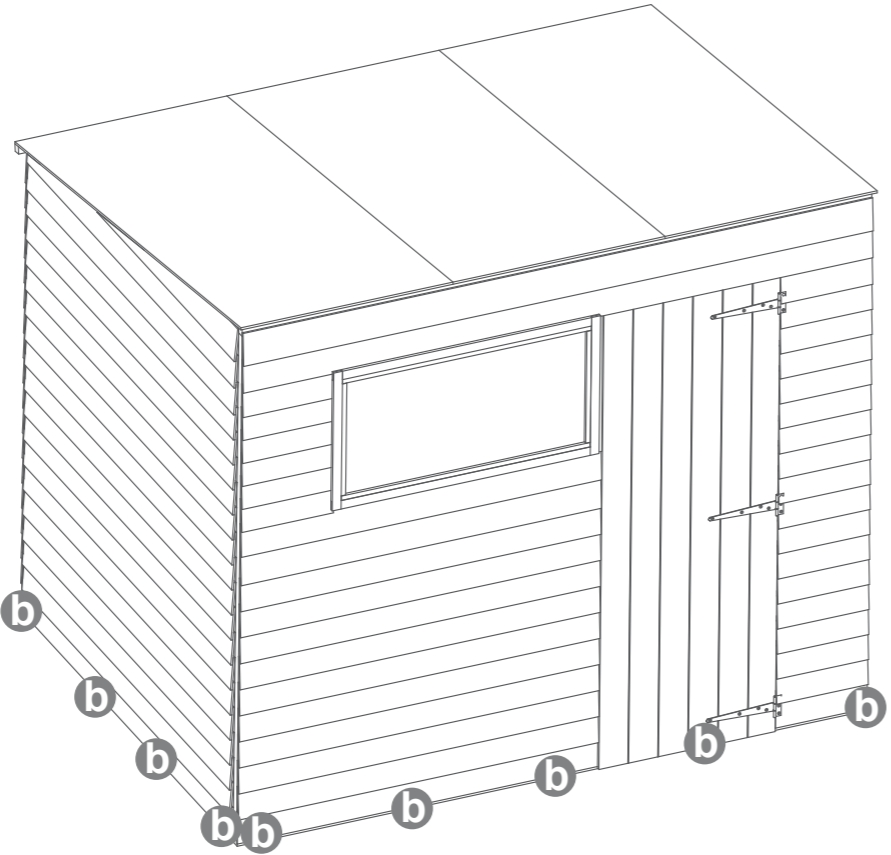
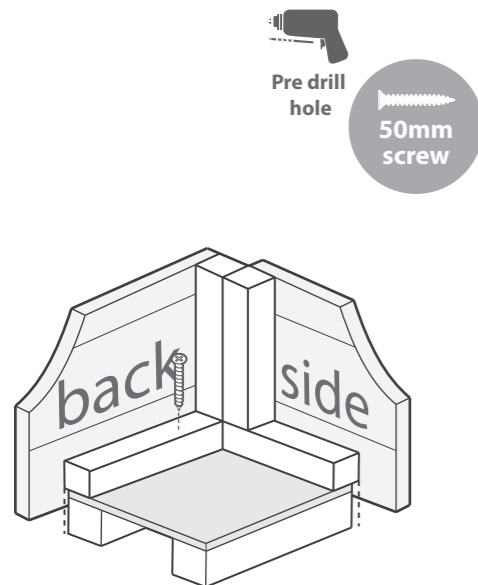

### Step 7

Cut the felt into 2x 2484mm long sheets and lay onto roof as shown in diagram ensuring there is overhang around the sides.

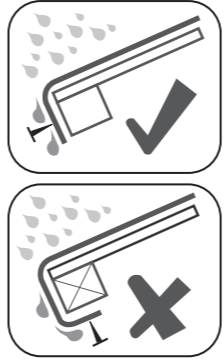

**90x felt tacks**

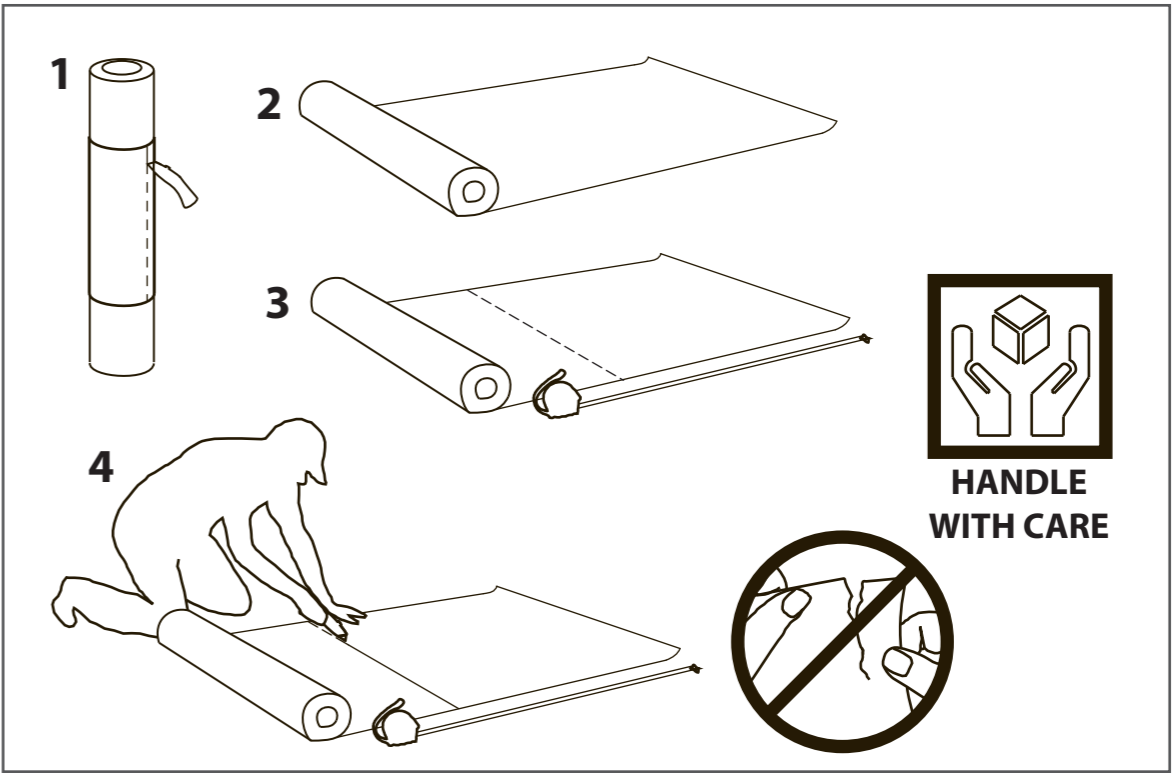
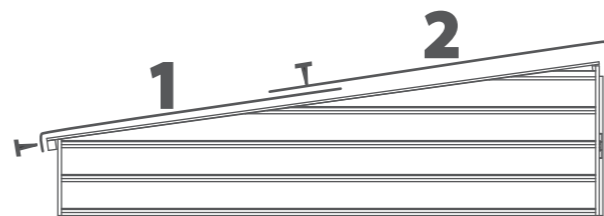
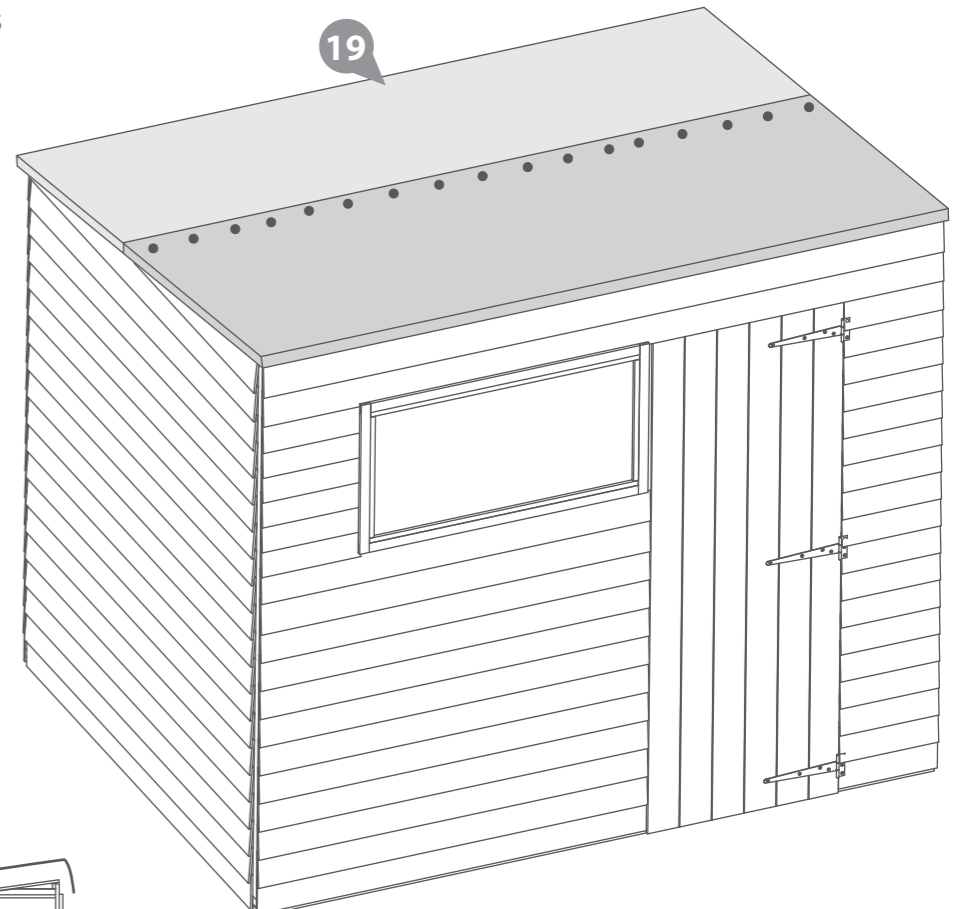

## Step 8

Fit the Cover Trims to the left and right of the building as shown in the illustration using 30mm screws. Trim the length of the cover trims to the required size before fitting if necessary.

Pre drill to avoid splitting.

**12x30mm Screws**

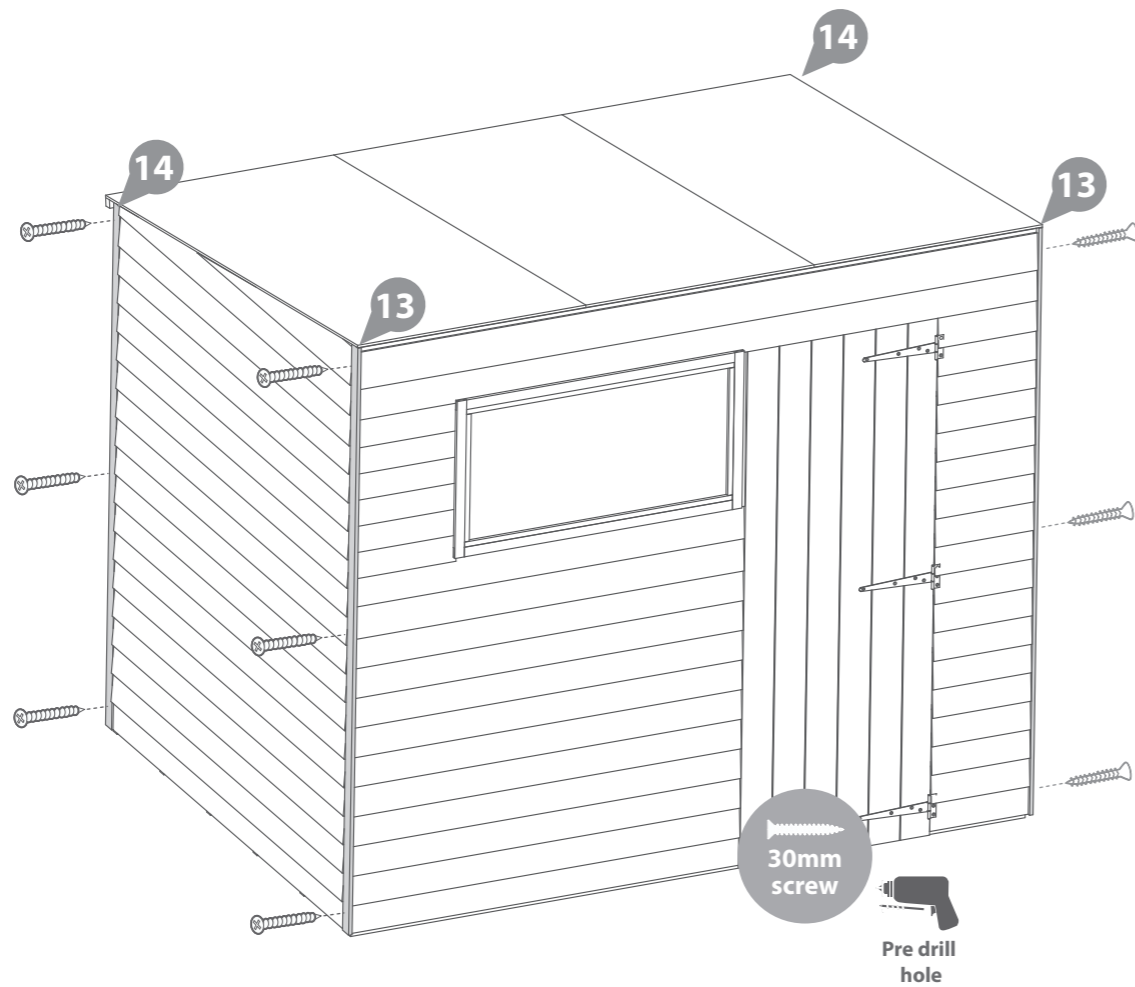
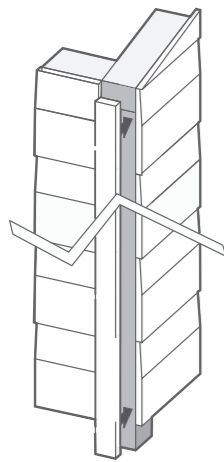

## Step 9

Attach the fascias to the roof leaving a slight overhang at the top.

Fit the fascias to the roof over the felt and secure in place with 40mm screws as shown. Pre drill to avoid splitting.

**10x40mm Screws**

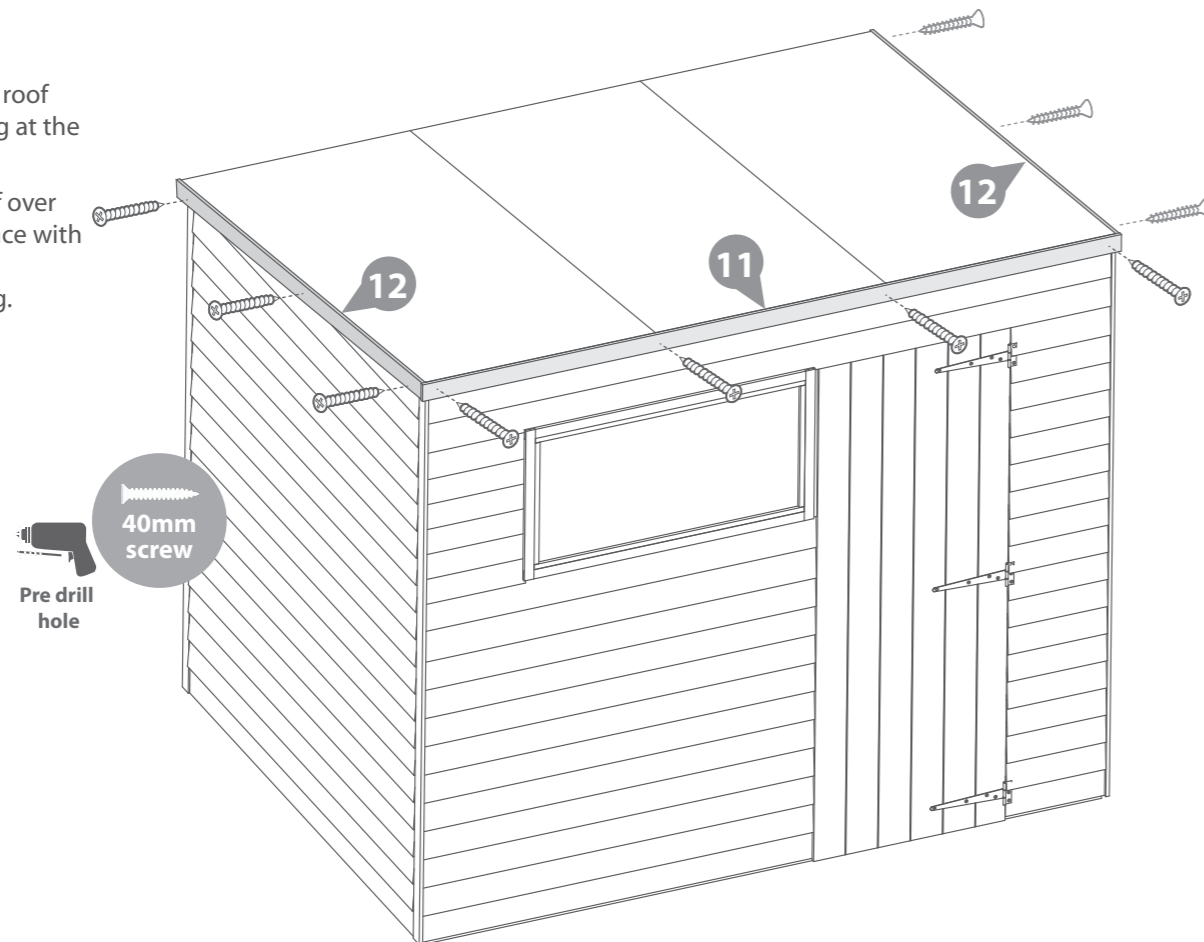

## Step 10

Use 4x30mm screws to fix each beading strip onto the door panel. Ensure that the screw is parallel with the door frame when fixing the strip to the door panel as shown in the close up view.

Line up the door block as shown in the illustration. Then fix with 2x30mm screws by screwing through the outside of the door into the block.

**10x30mm Screws**

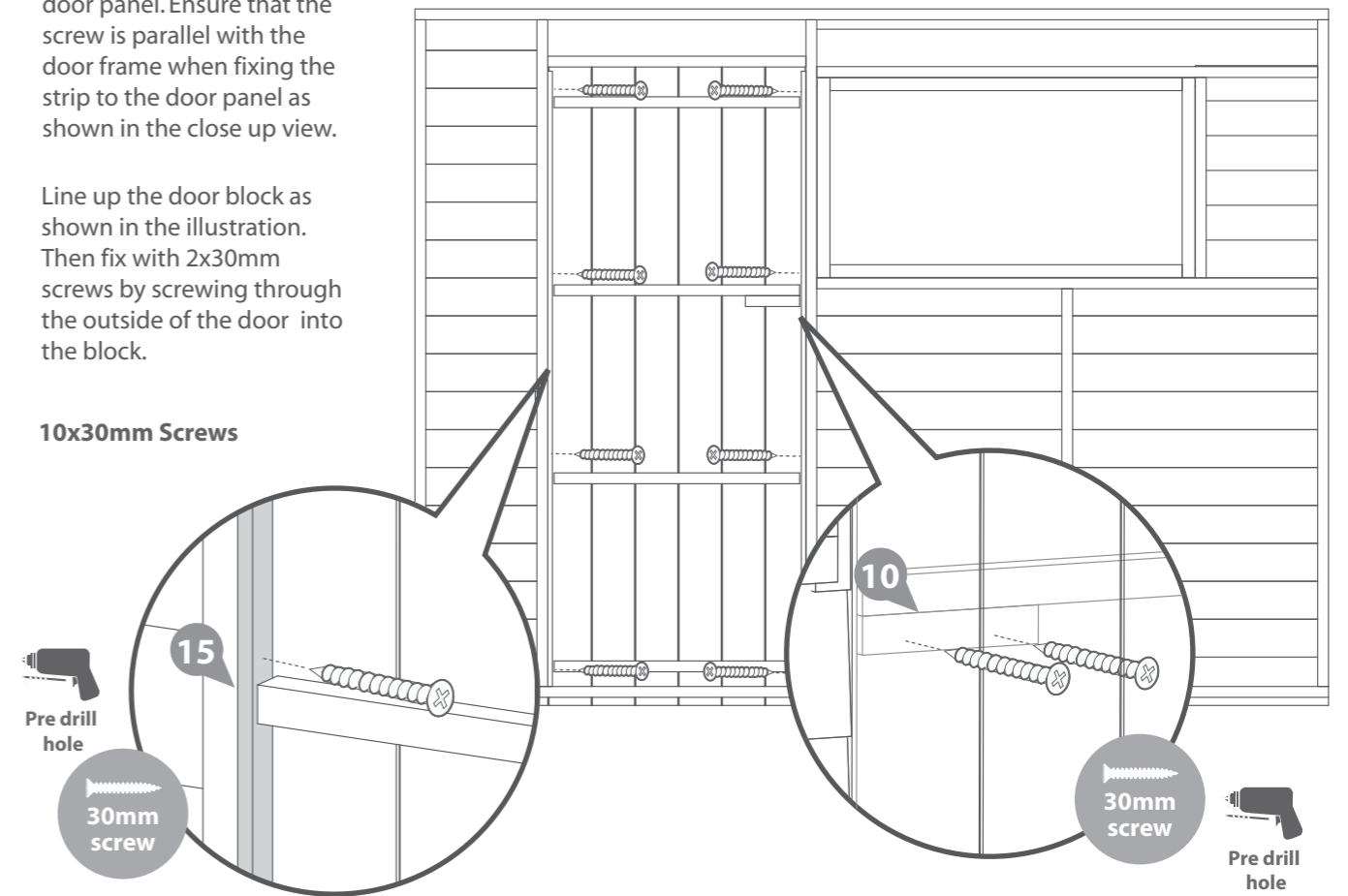

## Step 11

Fix the pad bolt with 6x30mm screws to the horizontal brace on the door. Then fix the pad bolt retainer to the door panel framing using 4x30mm screws.

Fix the turn buttons using 1x30mm black screw per turn button.

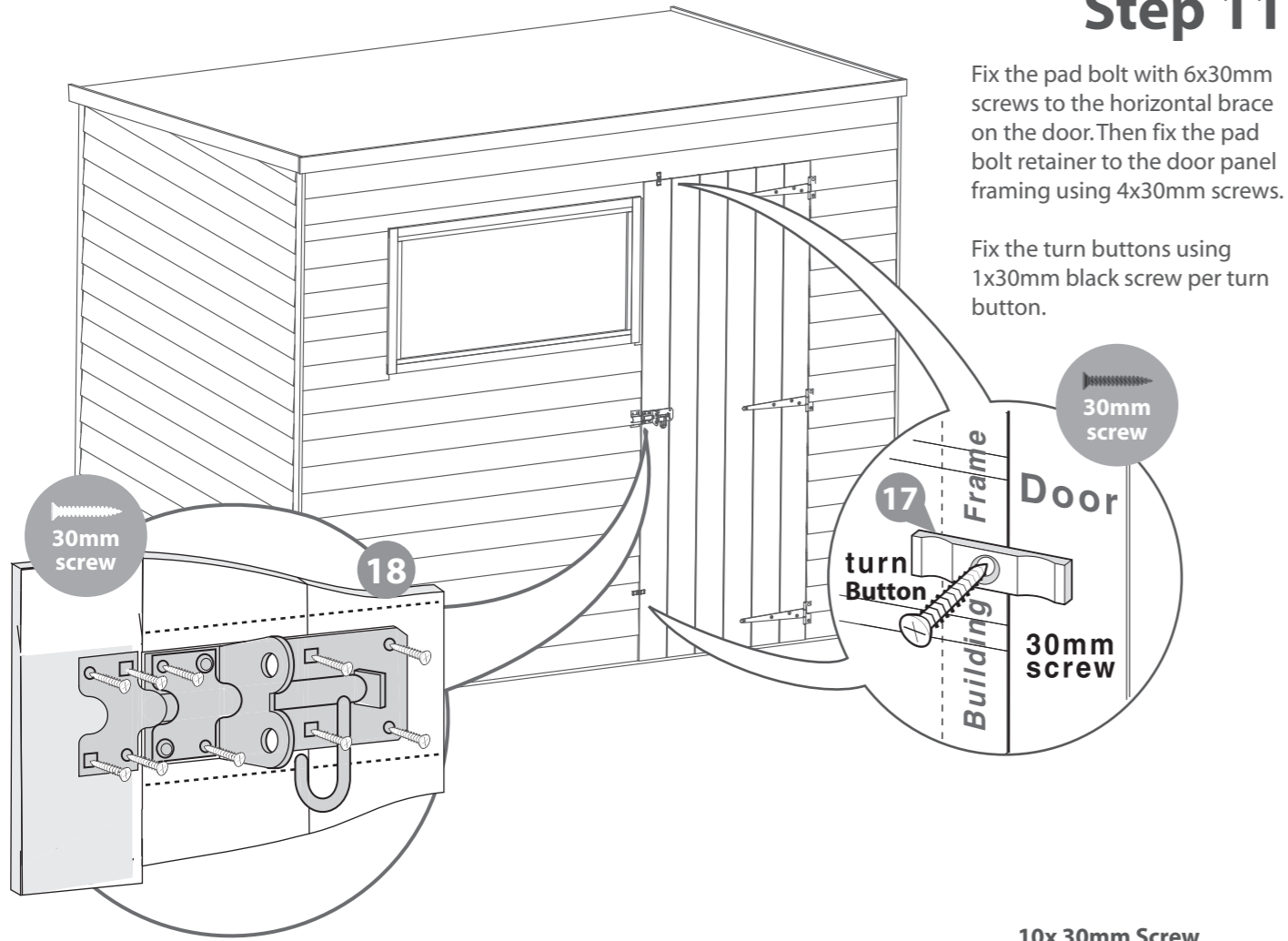

10x 30mm Screw  
2x 30mm Black Screw

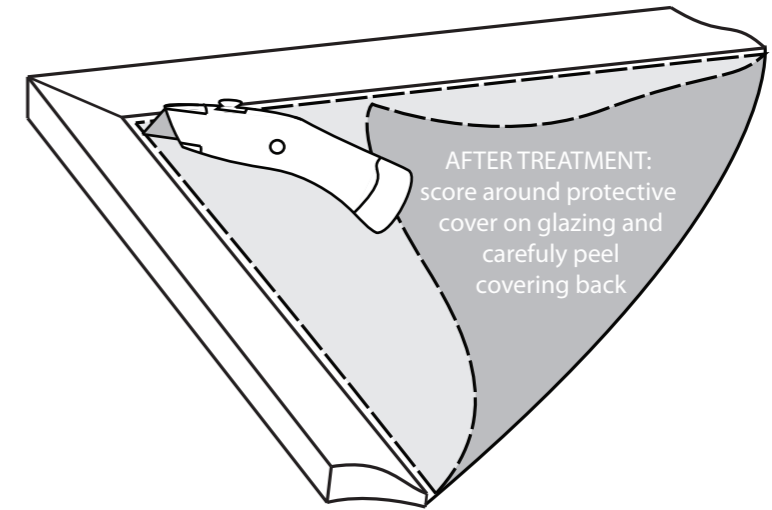

It is **ESSENTIAL** that you apply wood treatment immediately after the building has been assembled.

### Overall Dimensions:

Length = 1871mm  
Width = 3028mm  
Height = 2060mm

### Base Dimensions:

Length = 1757mm  
Width = 2974mm

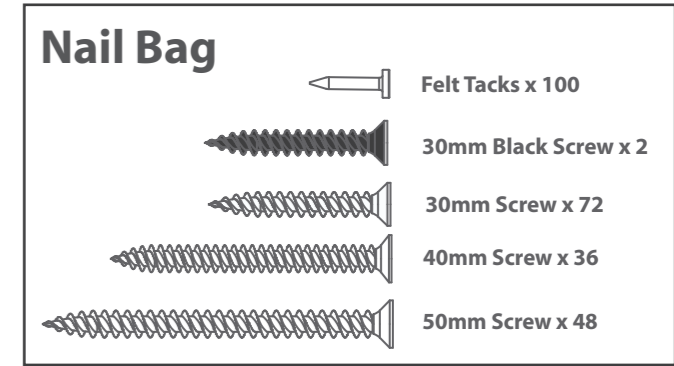
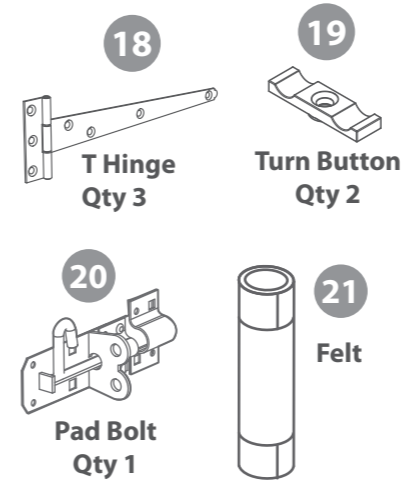
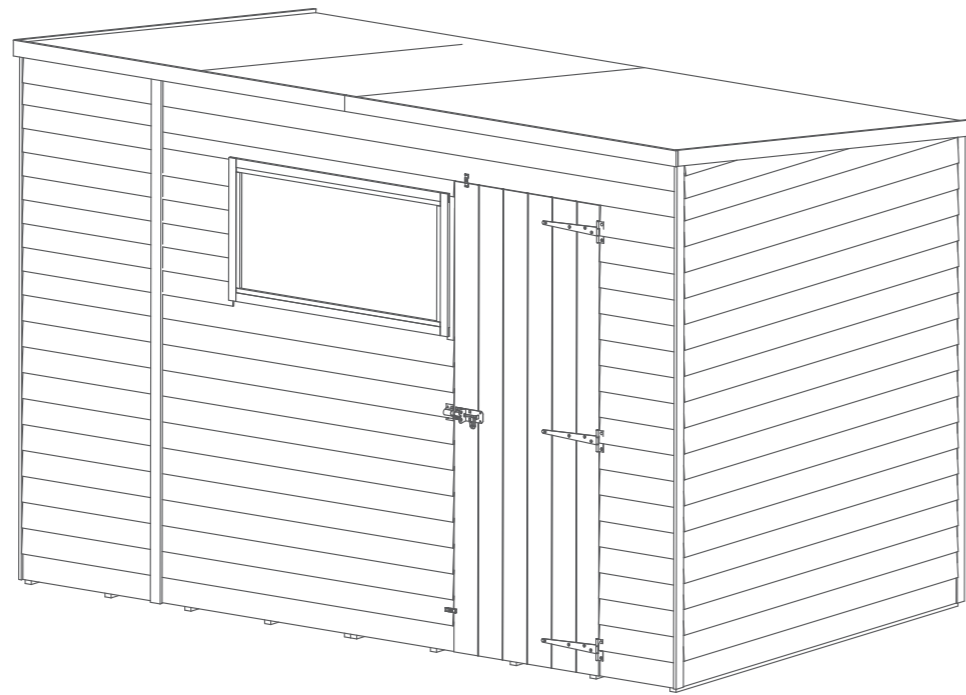

## Building Content

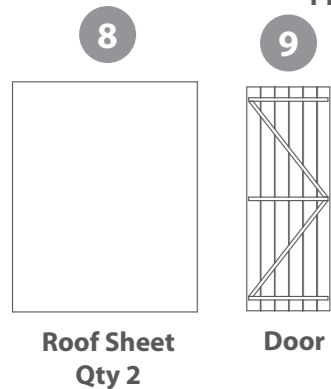
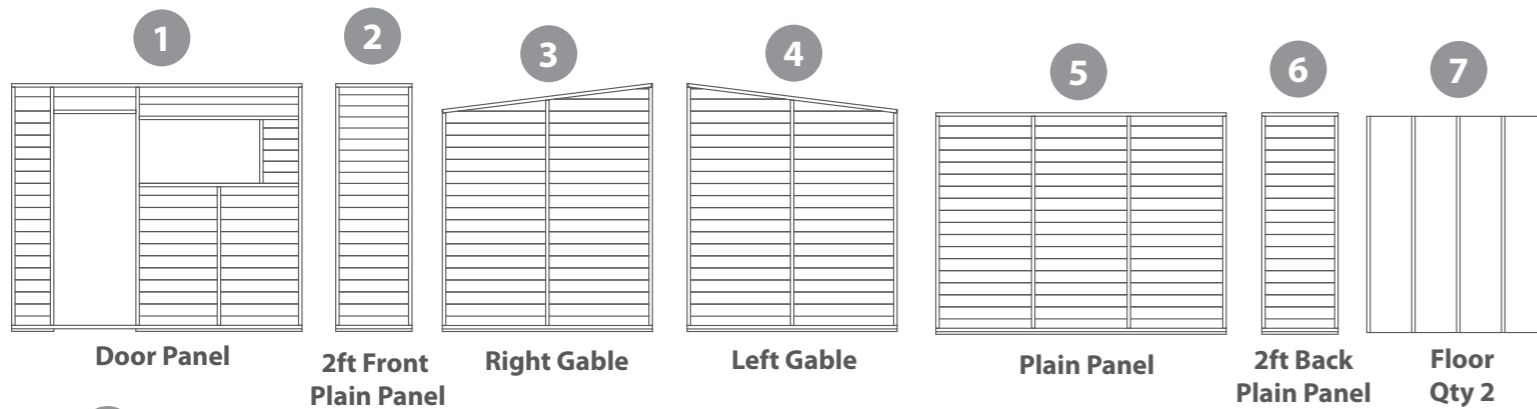

- 10 Ridge Bar - 1714mm Qty 3
- 11 Eaves Frame - 1502mm Qty 2
- 12 Door Block- 140mm Qty 1
- 13 Side Fascia- 1873mm Qty 2
- 14 Front Fascia- 1514mm Qty 2
- 15 Front Cover Trims- 2020mm Qty 3
- 16 Back Cover Trims- 1800mm Qty 3
- 17 Door Strip - 1720mm Qty 2

### Pre Assembly

Remove transportation blocks from the bottom of each panel before beginning assembly. Each Panel should have two

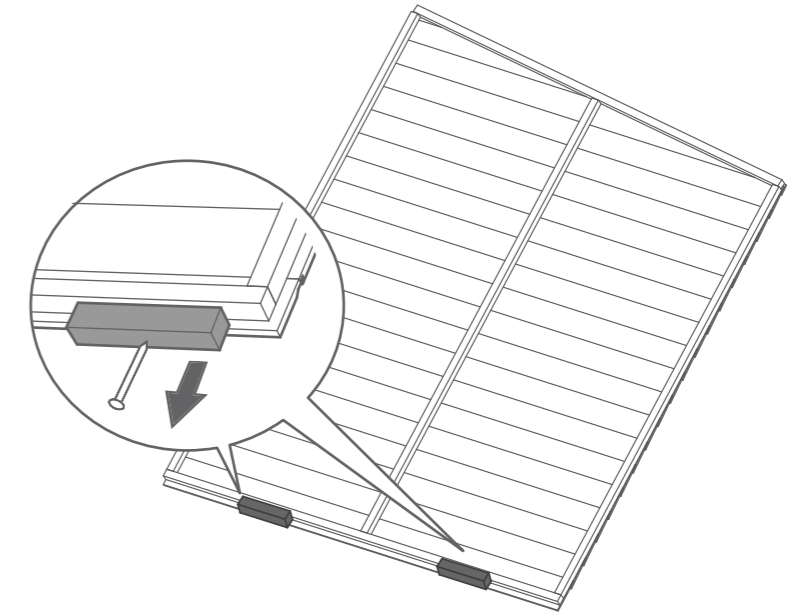

Fix the T Hinges onto the door and door frame as shown. Ensure that the screws go through the cladding and into the framing behind.

21x30mm screws

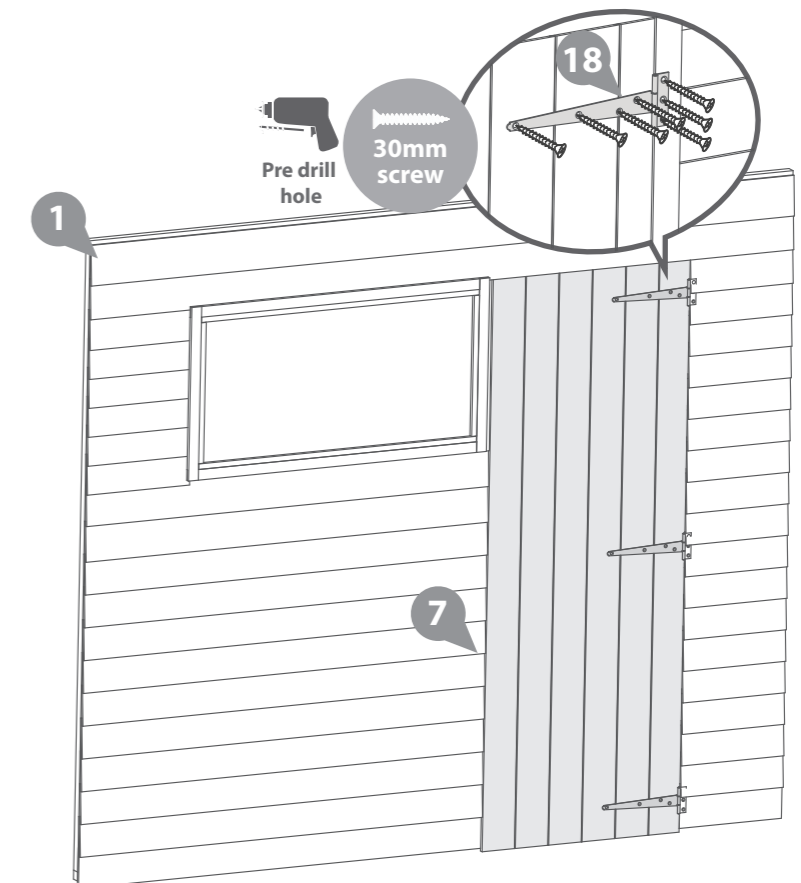

## Step 1

Place floor on firm and level base, ensure base has suitable drainage free from areas where water can collect. (See front page on base requirements).

Attach the floors using 12 x 30mm screws

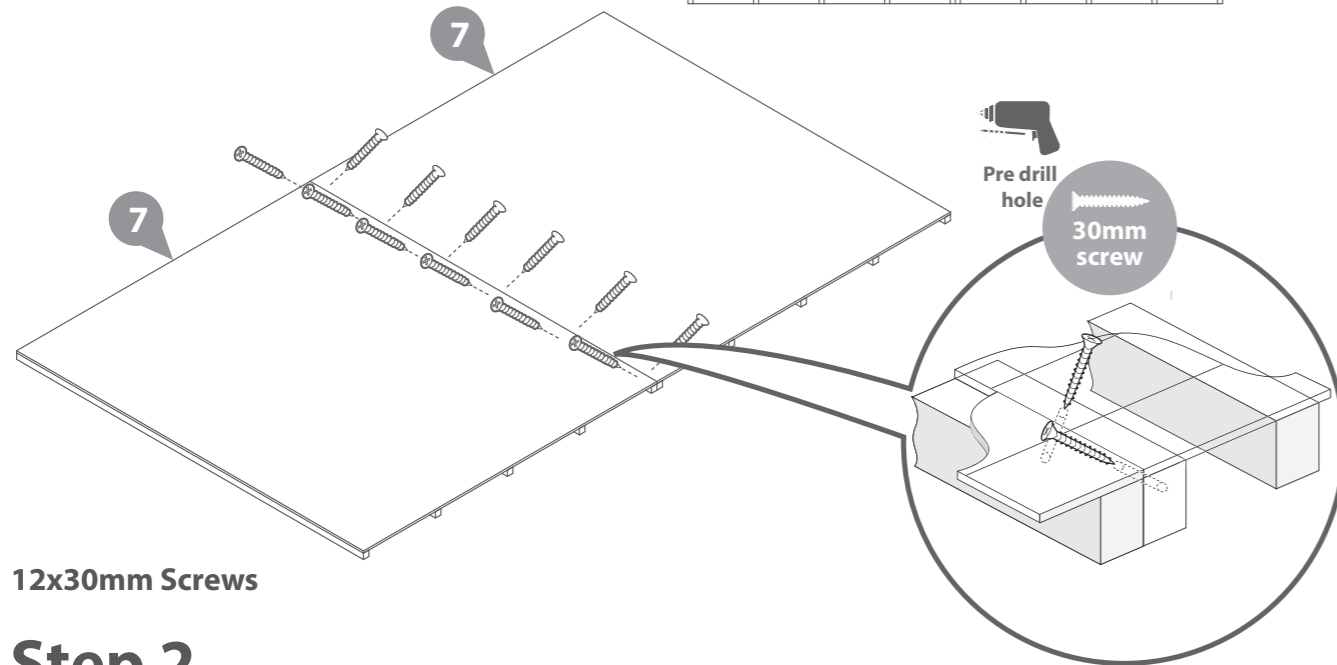

12x30mm Screws

## Step 2

Fix the corners with 50mm screws as shown in diagram.

Do not secure the building to the floor until the roof is fitted.

Position the panels so there is equal spacing between the floor and cladding on all 4 sides

7x50mm Screws

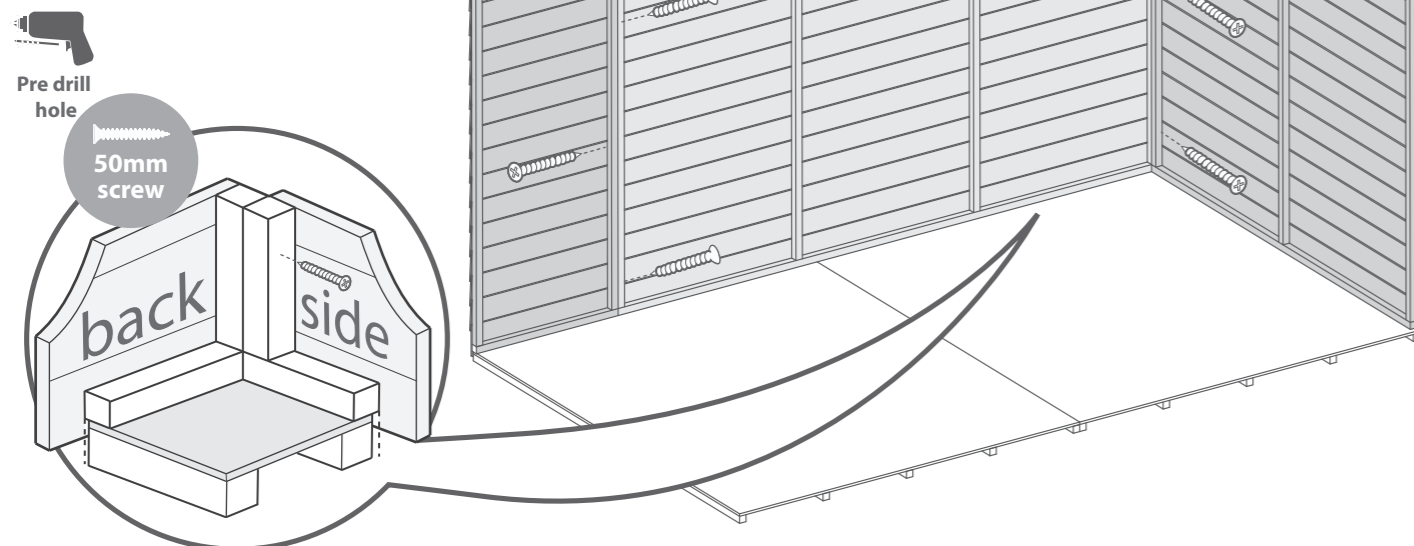

## Step 3

Fix the corners with 50mm screws as shown in diagram.

13x50mm Screws

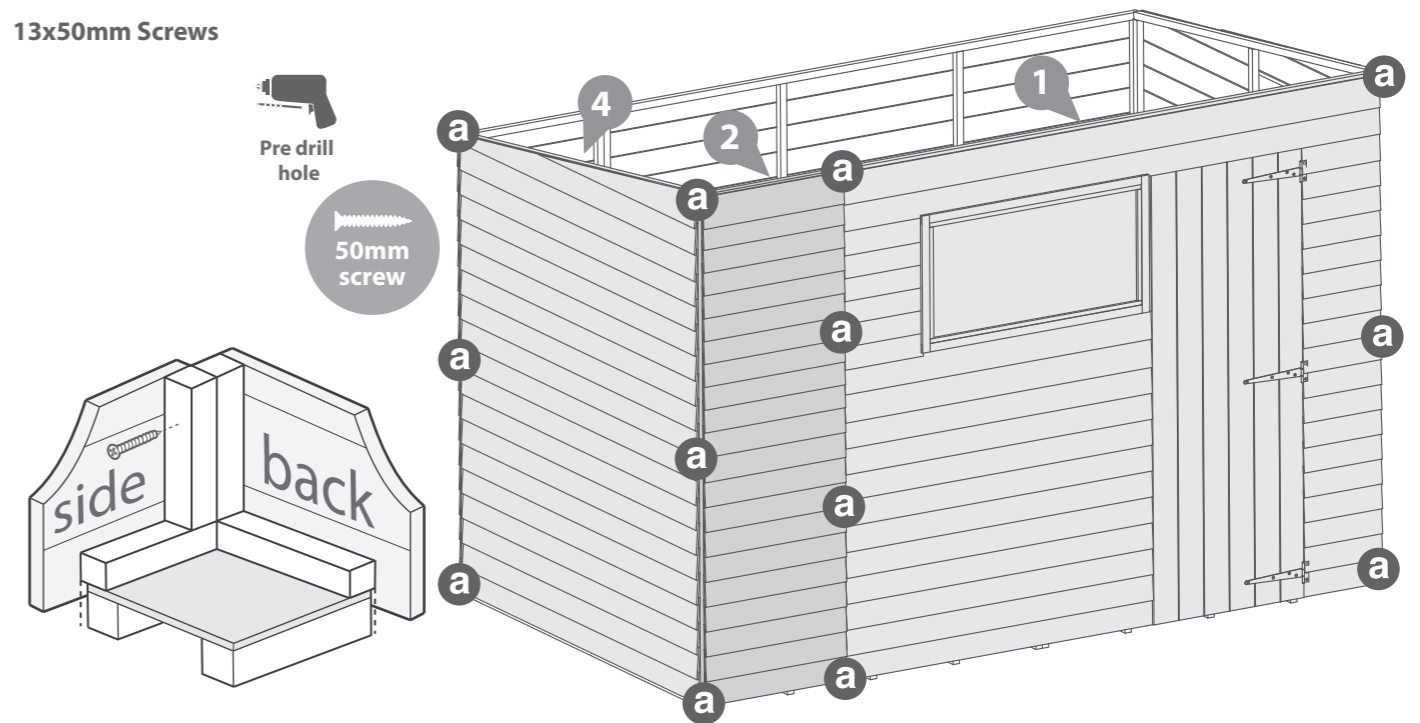

## Step 4

Position a ridge bar between the front and back of the building centralised between the two gables. Fix in place using a 50mm screws screwing through the outside of the building into the ridge bar.

Fix another two ridge bars centralised between the ridge bar you have just fitted and the closest gable.

6x50mm Screws

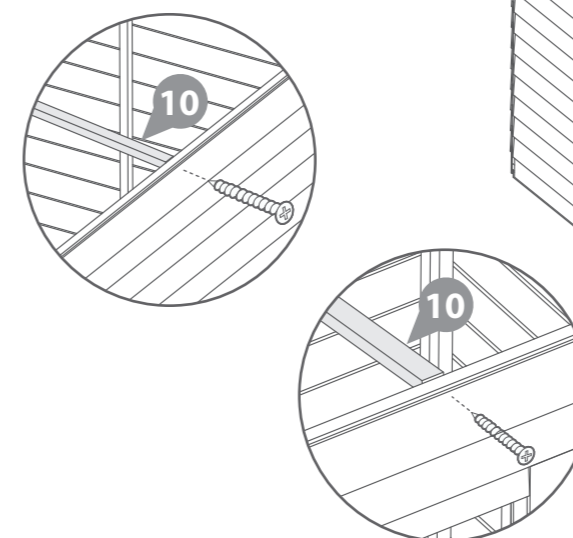

ENSURE SUPPORT BARS ARE MANUALLY SUPPORTED UNTIL FIXED AT BOTH ENDS

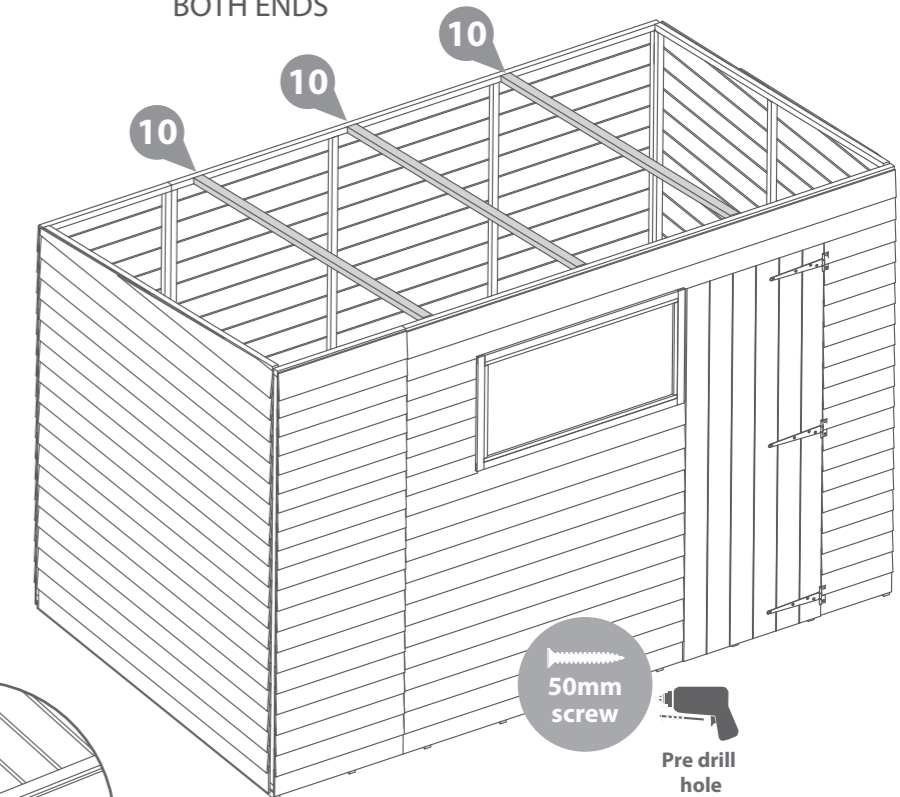

### Step 5

**a** Fix the eaves frame to the roof sheet using 4x30mm screws for each sheet.  
**8x30mm Screws**

**b** Place the two roof sheets onto the building, centralise them over the roof frames and make sure they finish flush with the front of the building. Fix in place with 40mm screws.

**22x40mm Screws**



30mm screw



40mm screw

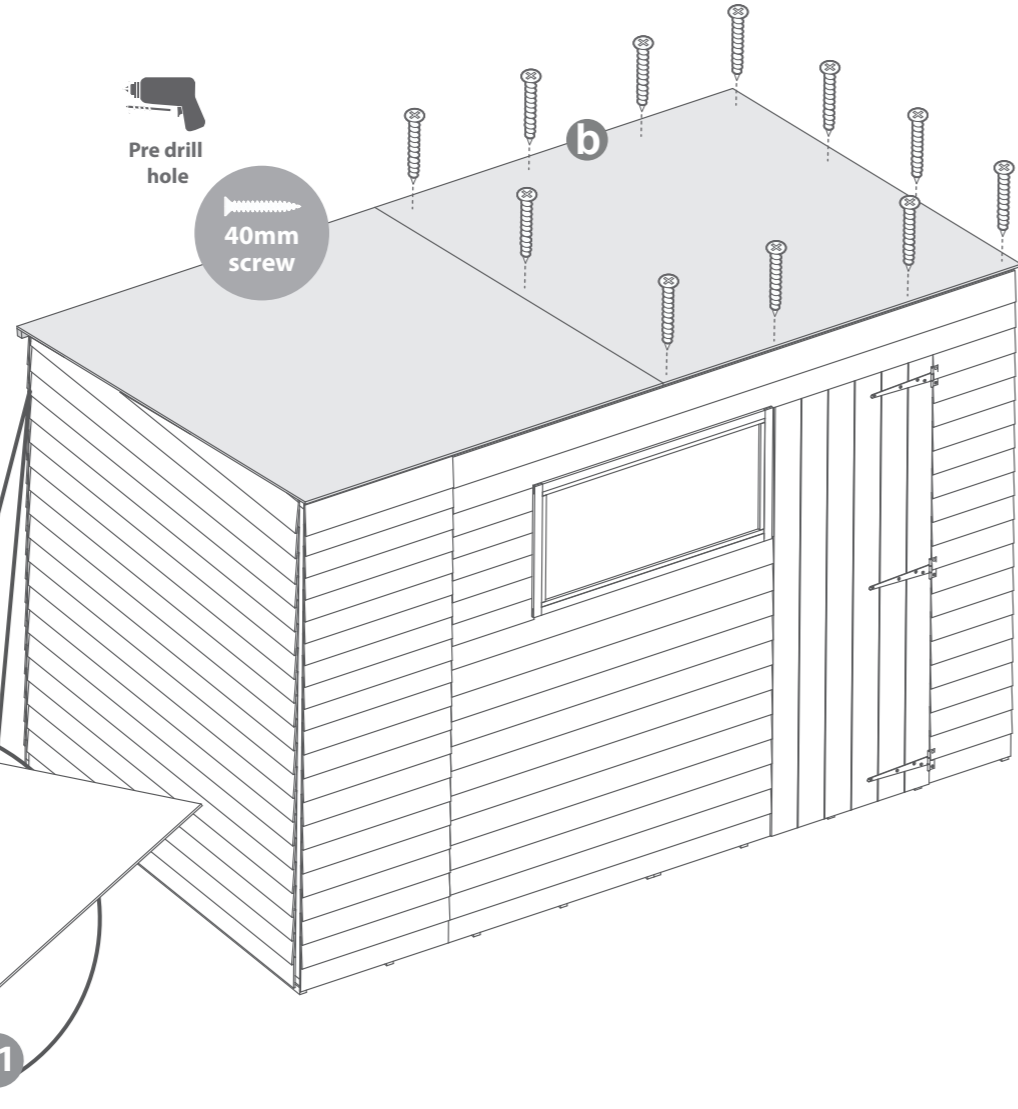

### Step 6

**b** Once the roof is fixed attach the building to the floor with 50 mm screws.

**20x 50mm Screws**



50mm screw

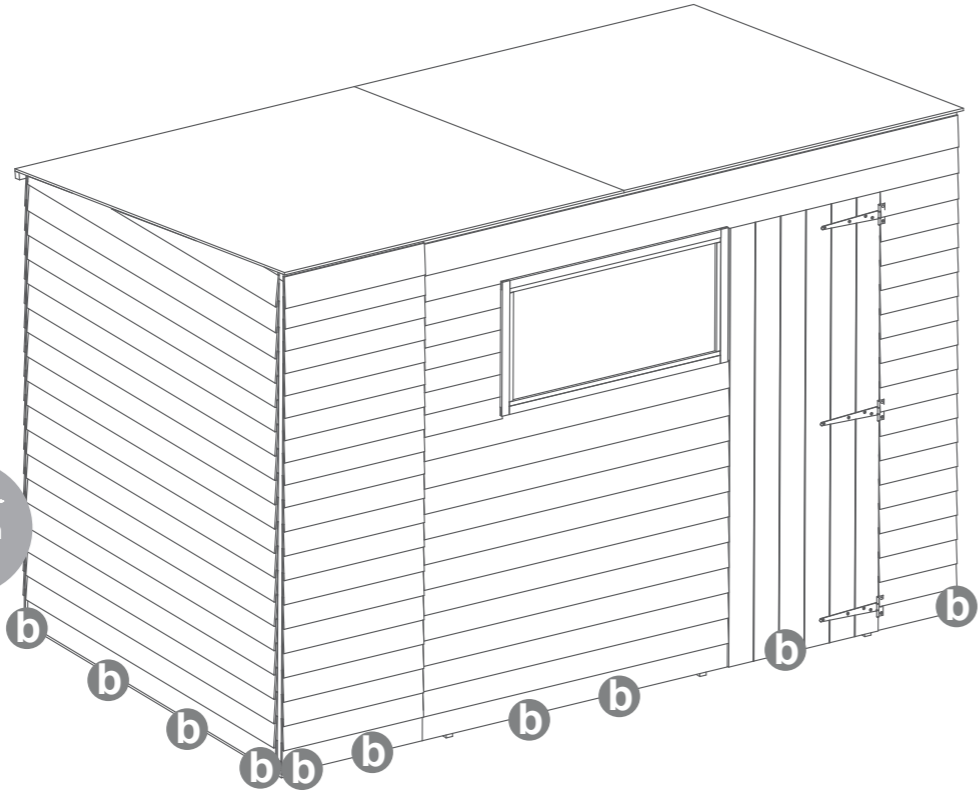
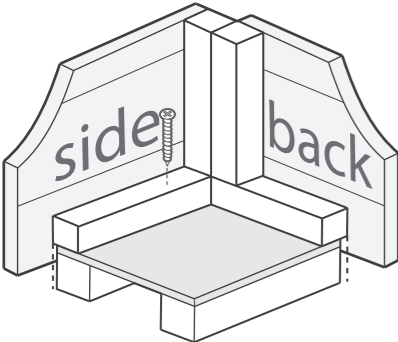

### Step 7

Cut the felt into 2x 3104mm long sheets and lay onto roof as shown in diagram ensuring there is overhang around the sides.



100x felt tacks

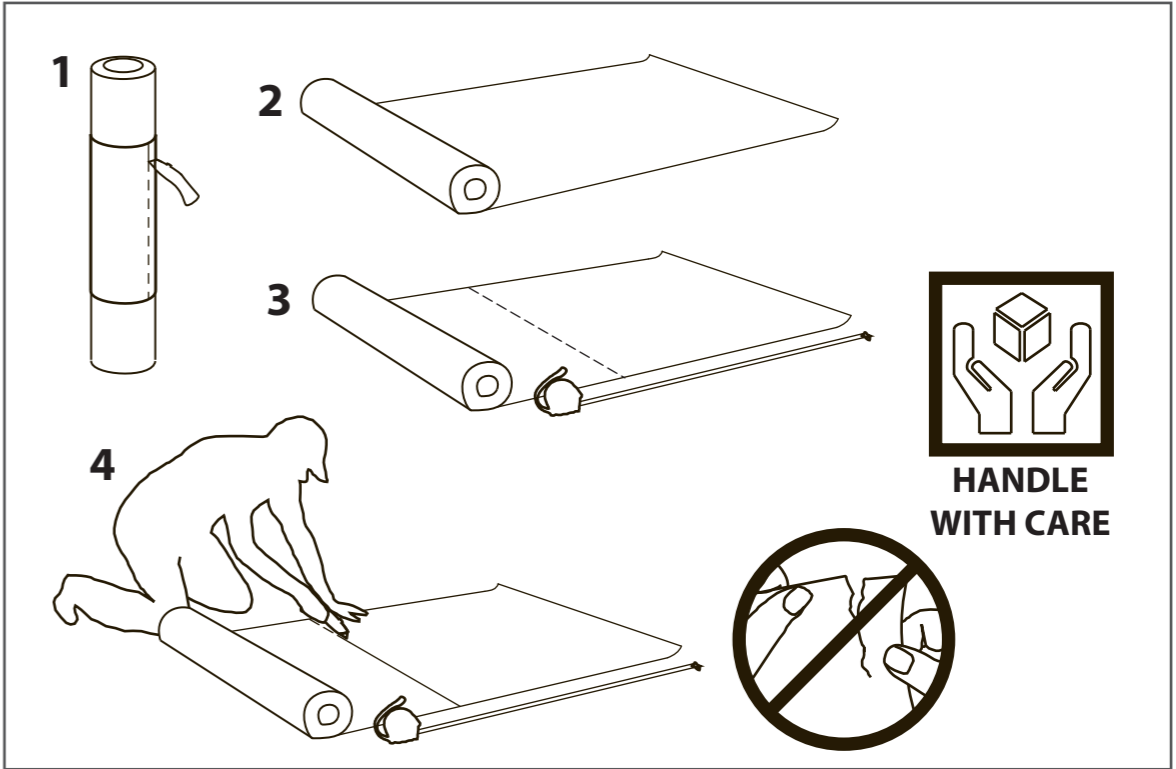
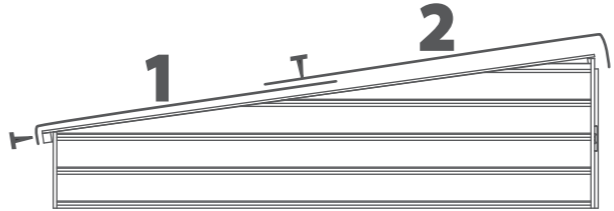
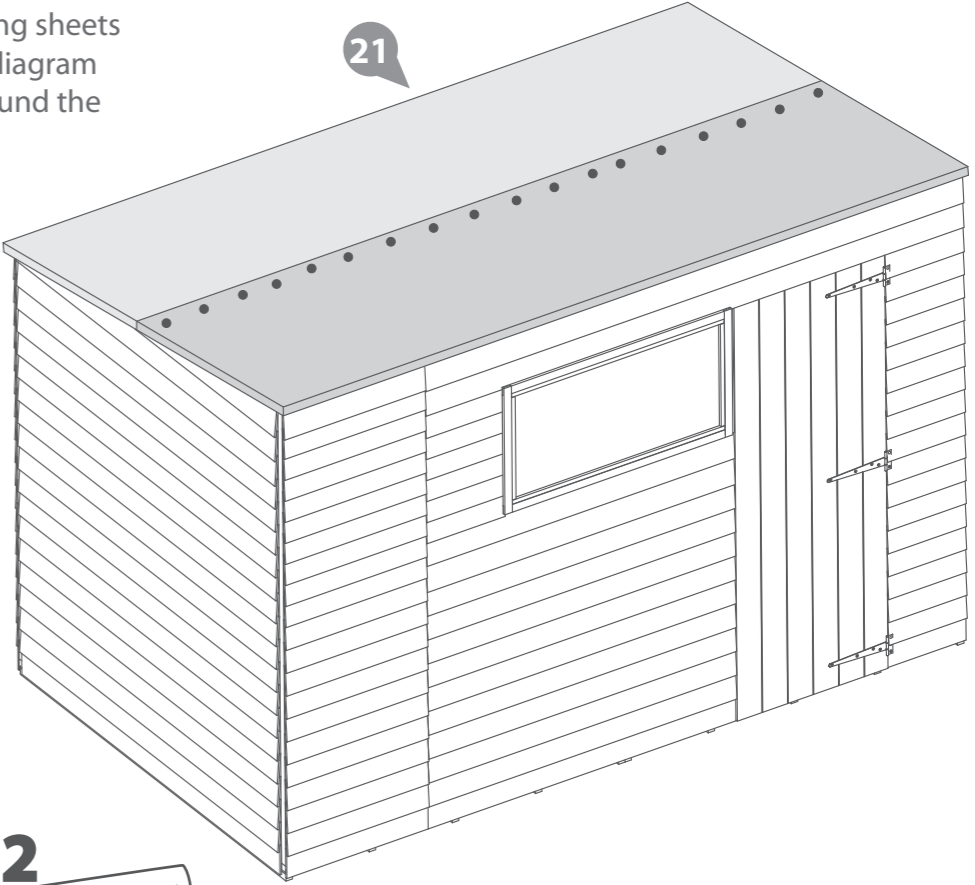

## Step 8

Fit the Cover Trims to the left and right of the building and over the panel joins as shown in the illustration using 30mm screws. Trim the length of the cover trims to the required size before fitting if necessary. Pre drill to avoid splitting.

**18x30mm Screws**

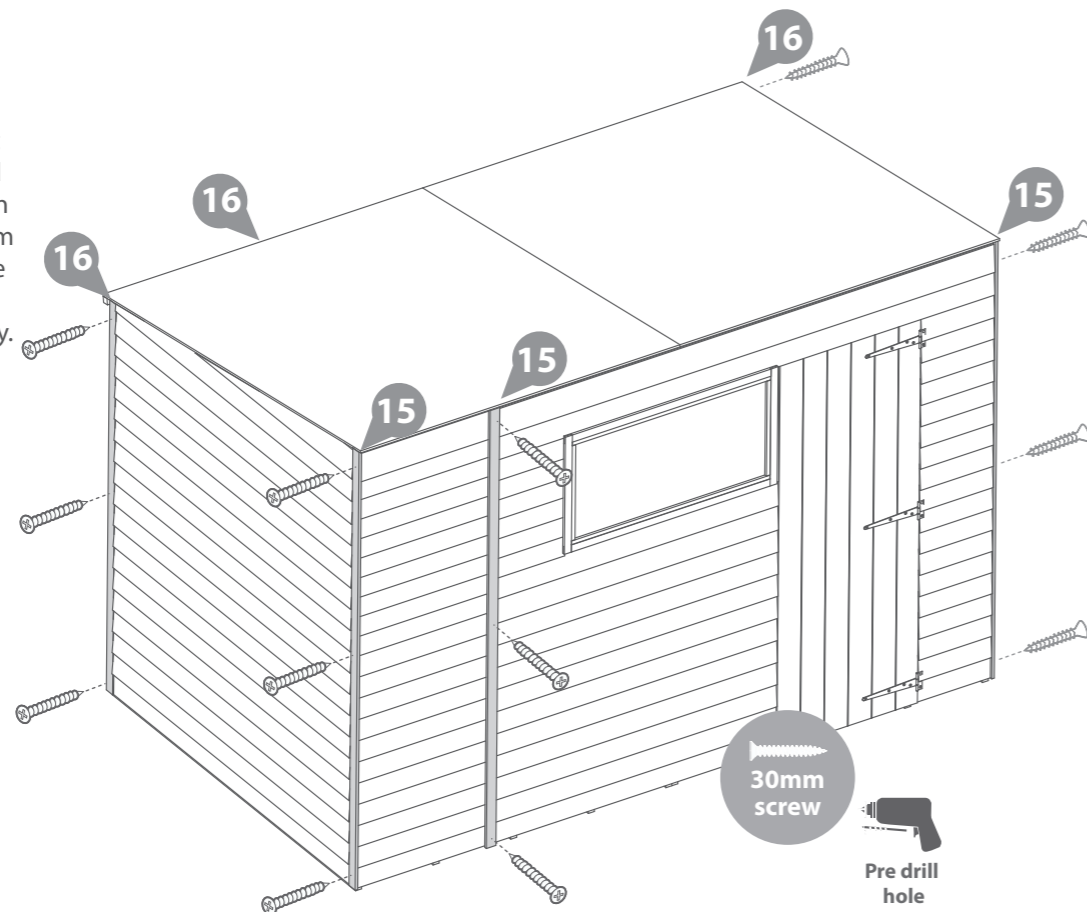
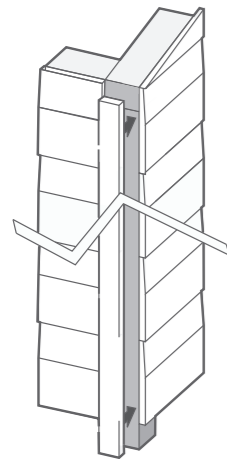

## Step 9

Attach the fascias to the roof leaving a slight overhang at the top.

Fit the fascias to the roof over the felt and secure in place with 40mm screws as shown. Pre drill to avoid splitting.

**12x40mm Screws**

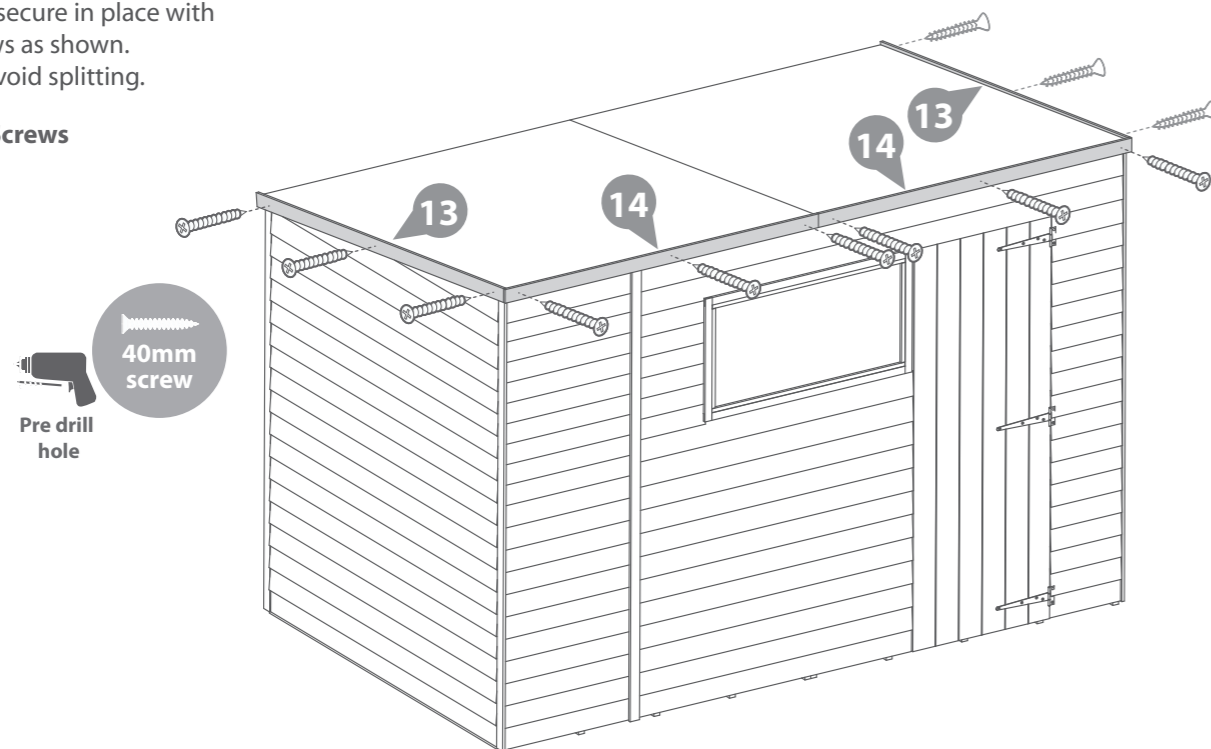

## Step 10

Use 4x30mm screws to fix each beading strip onto the door panel. Ensure that the screw is parallel with the door frame when fixing the strip to the door panel as shown in the close up view.

Line up the door block as shown in the illustration. Then fix with 2x30mm screws by screwing through the outside of the door into the block.

**10x30mm Screws**

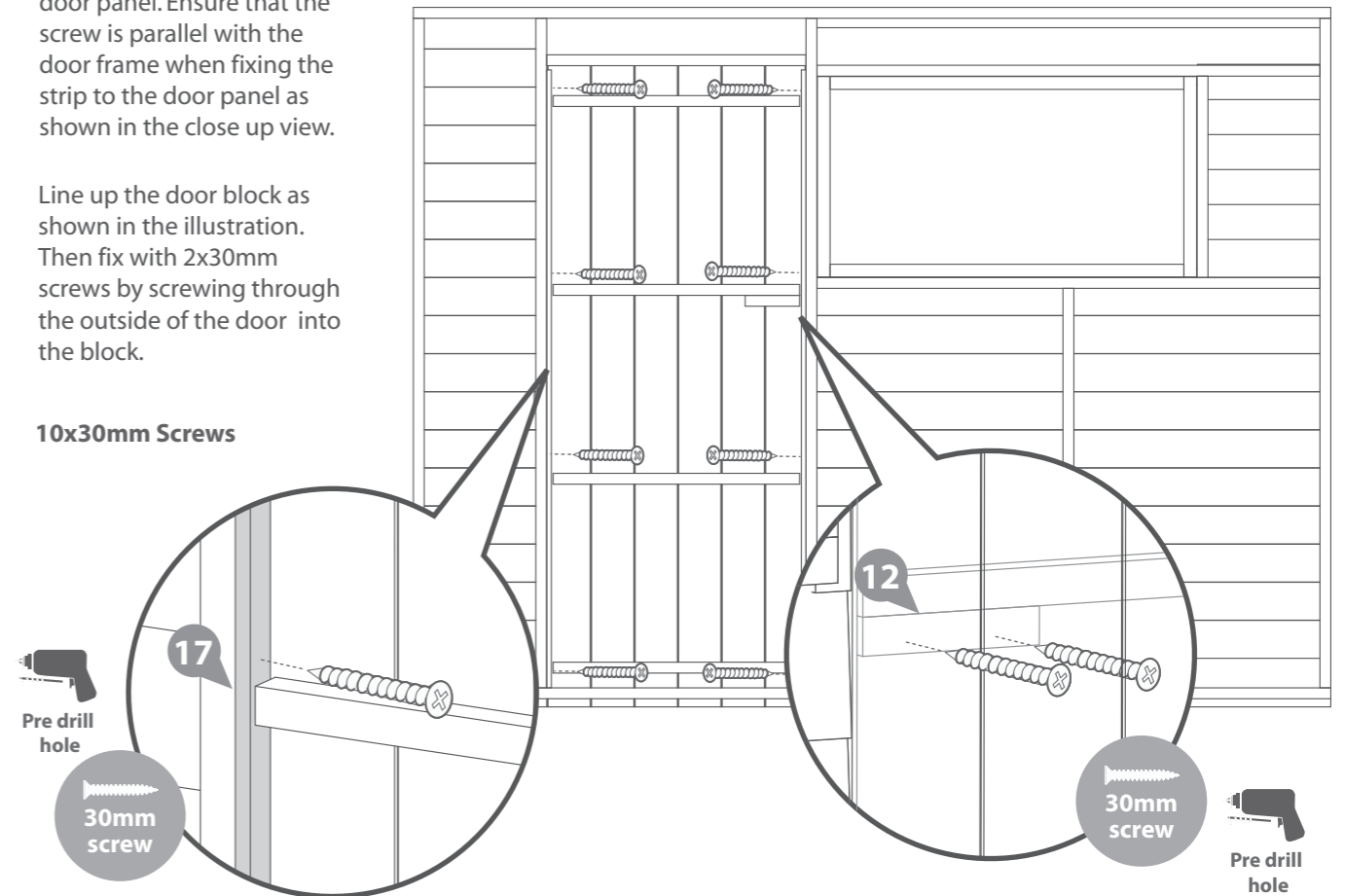

## Step 11

Fix the pad bolt with 6x30mm screws to the horizontal brace on the door. Then fix the pad bolt retainer to the door panel framing using 4x30mm screws.

Fix the turn buttons using 1x30mm black screw per turn button.

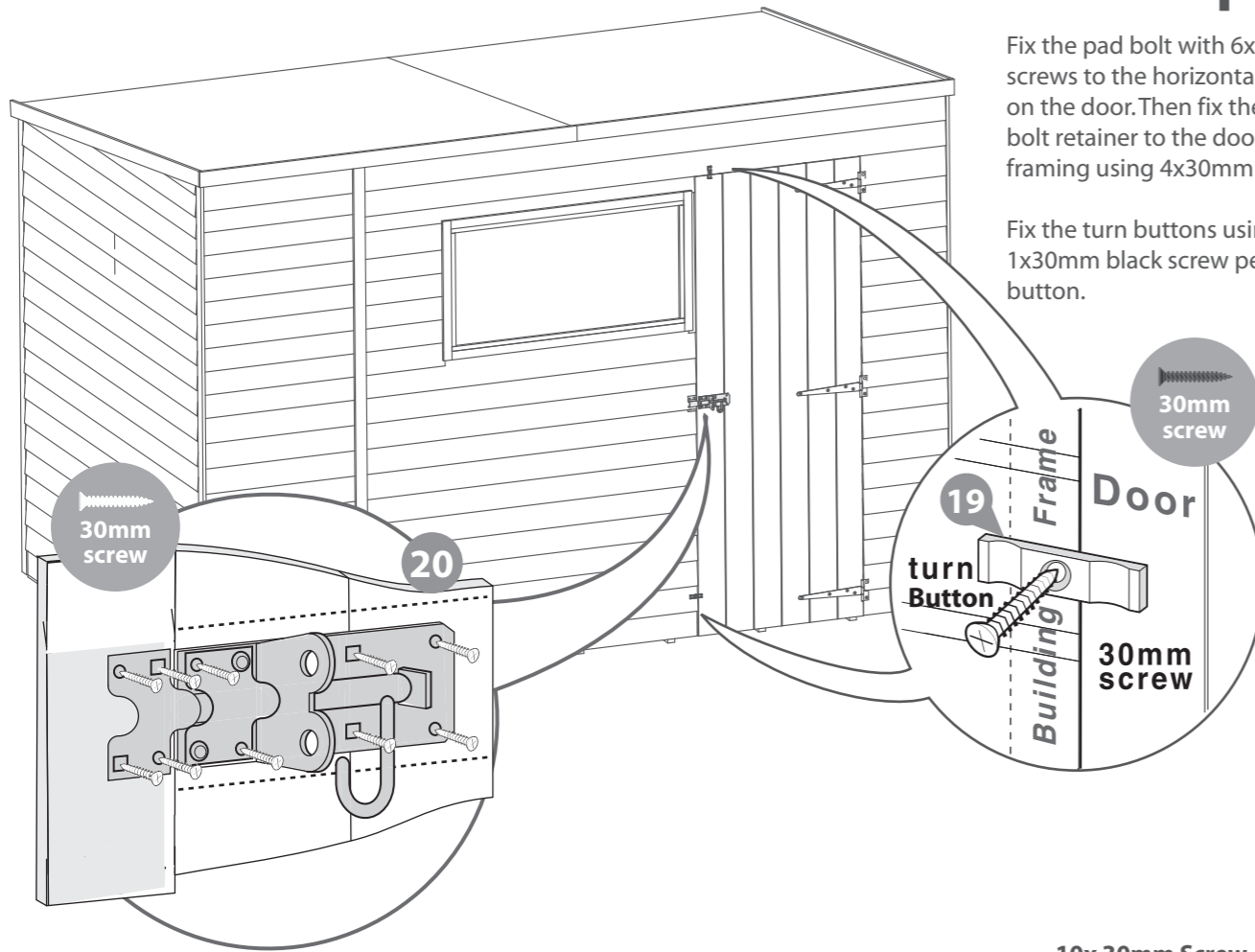

10x 30mm Screw  
2x 30mm Black Screw

