

BUSH

Instruction Manual

ME48115FF



You'll soon be enjoying your new refrigerator.

It all begins here, with your instructions. Don't worry, there's nothing too technical coming up. Just simple, step-by-step guidance to get you up and running quickly. Sound good? Then let's get started

Help and Guidance

We're here to help you get the most from your refrigerator. Should you require any guidance, a simple solution can often be found online at.

www.bush-support.com

If you still require further assistance, call one of our experts on 0345 257 7271.

Issue 1, 3/9/2024

If you require any technical guidance or find that your product is not operating as intended, a simple solution can often be found in the **Troubleshooting** section of these instructions.

Contents

1 Safety information

Safety information	6
--------------------	---

2 Getting to know your refrigerator

Ready? Let's begin...	13
Parts	14

3 Installing your refrigerator

Transportation	16
Installation	16
Electrical Connection	18

4 Using your refrigerator





Before first use	21
Using your appliance	21
Useful information	21

5 Care and Maintenance

General	26
Power failure	26
Moving your appliance	26
Technical Specifications	27
Disposal information	27

6 Product support

Trouble Shooting	30
Help and assistance	31
Guarantee	32

Icon	Type	Meaning
	WARNING	Serious injury or death risk
	RISK OF ELECTRIC SHOCK	Dangerous voltage risk
	FIRE	Warning; Risk of fire / flammable materials
	CAUTION	Injury or property damage risk
	IMPORTANT	Operating the system correctly

If you require any technical guidance or find that your product is not operating as intended, a simple solution can often be found in the Troubleshooting section of these instructions.

Safety information

1





Safety information

Important-Please read these instructions fully before installing or operating

Before use

The installation of this appliance is best carried out by 2 people.

- Dispose of all packaging carefully and responsibly.
- The appliance is designed for **indoor use only** and must be protected from rain, moisture and extreme temperature variations.
- This appliance is designed for house hold use. **Do not** use the appliance for industrial and commercial use, or any other purpose.
- The appliance **MUST** be positioned on a firm level base.
- **Do not** splash water on the appliance. It may cause electrical parts to fail and result in an electric shock.
- Leave the appliance in its intended place of installation and in its correct orientation for at least 4 hours before switching on to allow the cooling system to settle before first use or after any transportation.
- Your appliance is an environmental friendly product and it contains non CFC/HFC gas substances in the cooling system (Called R600a) and in the insulation (Called cyclopentane) which are potentially flammable if exposed to fire. Therefore, take care not to damage, the cooling circuit/pipes of the appliance in transportation and in use. In case of damage do not expose the appliance to fire,



Safety information

Important-Please read these instructions fully before installing or operating

- potential ignition source and immediately ventilate the room where the appliance is situated.
- **Do not** sit, stand or place any other heavy objects on top of the appliance. This could result in injury or damage to the appliance.
 - **Do not** allow children to play with the appliance to avoid the risk of entrapment and suffocation.
 - **⚠ WARNING!** Keep ventilation opening, in the appliance enclosure or in the built-in structure, clear of obstruction.
During use
 - This appliance is not intended for use by persons (including children) with reduced physical, sensory or mental capabilities, or lack of experience and knowledge, unless they have been given supervision or instruction concerning use of the appliance by a person responsible for their safety. Children should be supervised to ensure that they do not play with the appliance.
 - This appliance is not intended for use by young children or infirm persons unless they have been adequately supervised by a responsible person to ensure that they can use the appliance safely. Young children should be supervised to ensure that they do not play with the appliance.
 - **⚠ WARNING!**
Do not use mechanical,



Safety information

Important-Please read these instructions fully before installing or operating

electrical or chemical way to speed up the defrost process not recommended by the manufacturer.

- **⚠ WARNING!**

- **Do not** use or place other electrical products inside the appliance not recommended by the manufacturer.

- **Do not** store liquids in glass containers in the freezer compartment as these may shatter.

- **Do not** store flammable materials such as alcohol, gasoline, LP gas or glue etc in the appliance.

- In case there is an inflammable gas leaking, open the window for air circulation and do not pull out the plug or

turn the temperature knob. **Do not** touch the appliance until the valve of gas is turned off. Otherwise, sparks may happen.

- This appliance can be used by children aged from 8 years and above and persons with reduced physical, sensory or mental capabilities or lack of experience and knowledge if they have been given supervision or instruction concerning use of the appliance in a safe way and understand the hazards involved.

Children shall not play with the appliance.

Cleaning and user maintenance shall not be made by children without supervision.

- **Do not** attempt to repair the appliance yourself. Contact the Customer Helpline:0345 257 7271.



Safety information

Important-Please read these instructions fully before installing or operating

- Children aged from 3 to 8 years are allowed to load and unload this appliance.
- **⚠ WARNING!** When positioning the appliance, ensure the supply cord is not trapped or damaged.
- **⚠ WARNING!** Do not locate multiple portable socket-outlets or portable power suppliers at the rear of the appliance.
- **CORD ENTANGLEMENT HAZARD**
The cable of the appliance can give rise to risks of entanglement, strangulation or tripping if not correctly placed.
You must make sure that the electric cable is positioned safely.
- To avoid contamination of food, please respect the following instructions:
 - Opening the door for long periods can cause a significant increase of the temperature in the compartments of the appliance.
 - Clean regularly surfaces that can come in contact with food and accessible drainage systems.
 - Clean water tanks if they have not been used for 48h; flush the water system connected to a water supply if water has not been drawn for 5 days.
 - Store raw meat and fish in suitable containers in the refrigerator, so that it is not in contact with or drip onto other food.
 - Two-star frozen-food compartments(if they are presented in the appliance) are suitable for storing pre-frozen food, storing or making ice-cream and making ice cubes.

If you require any technical guidance or find that your product is not operating as intended, a simple solution can often be found in the **Troubleshooting** section of these instructions.





Safety information

Important-Please read these instructions fully before installing or operating

One-, two- and three-star compartments (if they are presented in the appliance) are not suitable for the freezing of fresh food.

- If the appliance is left empty for long periods, switch off, defrost, clean, dry and leave the door open to prevent mould developing within the appliance.
- The refrigerating appliance is not intended to be used as a built-in appliance, unless specifically shown as such into its instruction manual.
- The drawers, baskets and shelves should be kept in their current position unless otherwise specified in this document.

-   **WARNING!** During using, service and disposal the appliance, please pay attention to symbol similar as left side, which is located on rear of appliance (rear panel or compressor) and with yellow or orange color.

It's risk of fire warning symbol. There are flammable materials in refrigerant pipes and compressor. Please be far away fire source during using, service and disposal.

-  **WARNING!** Do not damage the refrigerant circuit.

- If the supply cord is damaged, it must be replaced by the manufacturer, its service agent or similarly qualified persons in order to avoid a hazard.





Getting to know your refrigerator 2

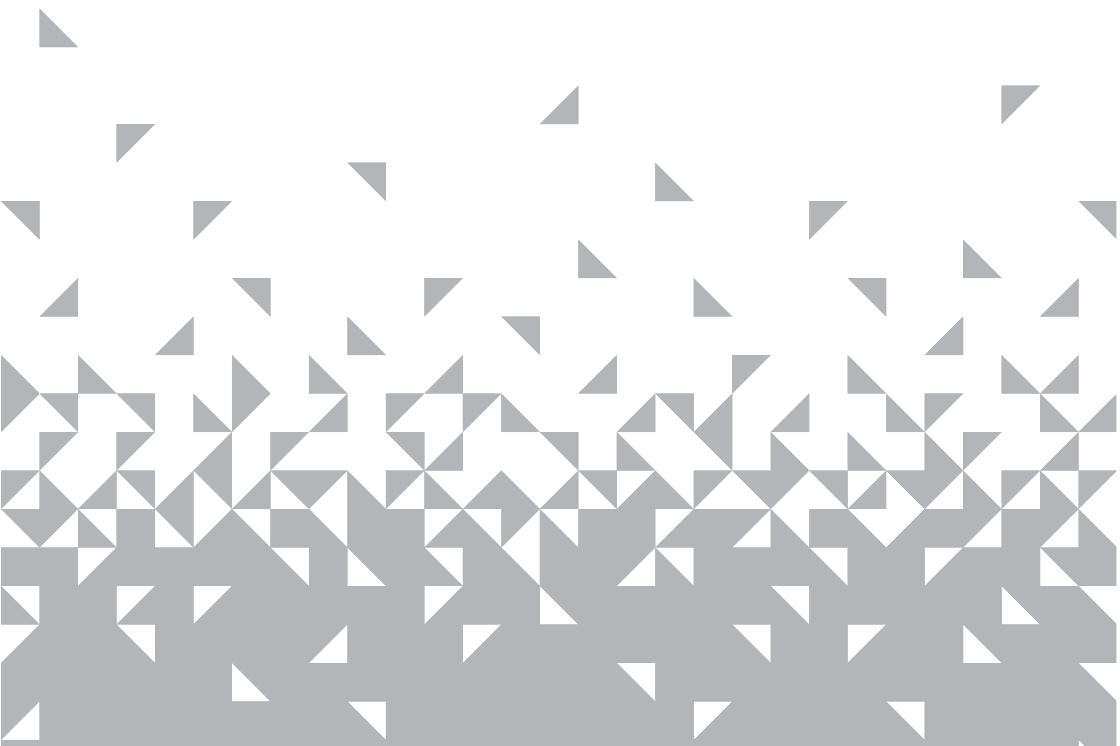

Getting to know your refrigerator

You'll be up and running in no time

Ready? Let's begin...

Please read these instructions carefully. They contain important information which will help you get the best from your refrigerator and ensure safe and correct installation and operation

If you require any further assistance, our technical experts are happy to help. For full details, refer to the product support section at the end of these instructions.

Getting to know your refrigerator

You'll be up and running in no time

Parts

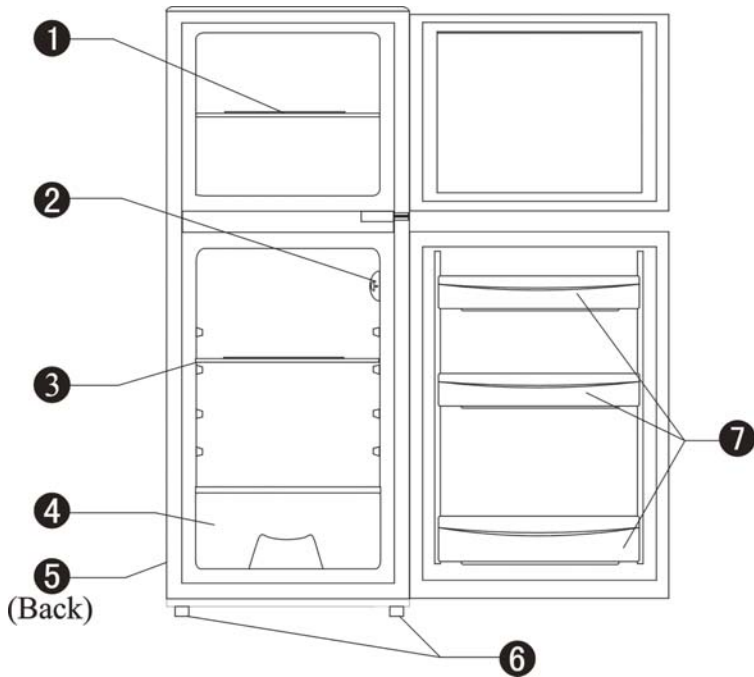

- 1. Freezer shelf
- 2. Thermostat and light
- 3. Fridge shelf
- 4. Crisper

- 5. Compressor
- 6. Leveling feet
- 7. Door bracket

Accessories included



Instructions x 1

If you require any technical guidance or find that your product is not operating as intended, a simple solution can often be found in the **Troubleshooting** section of these instructions.

Installing your refrigerator 3

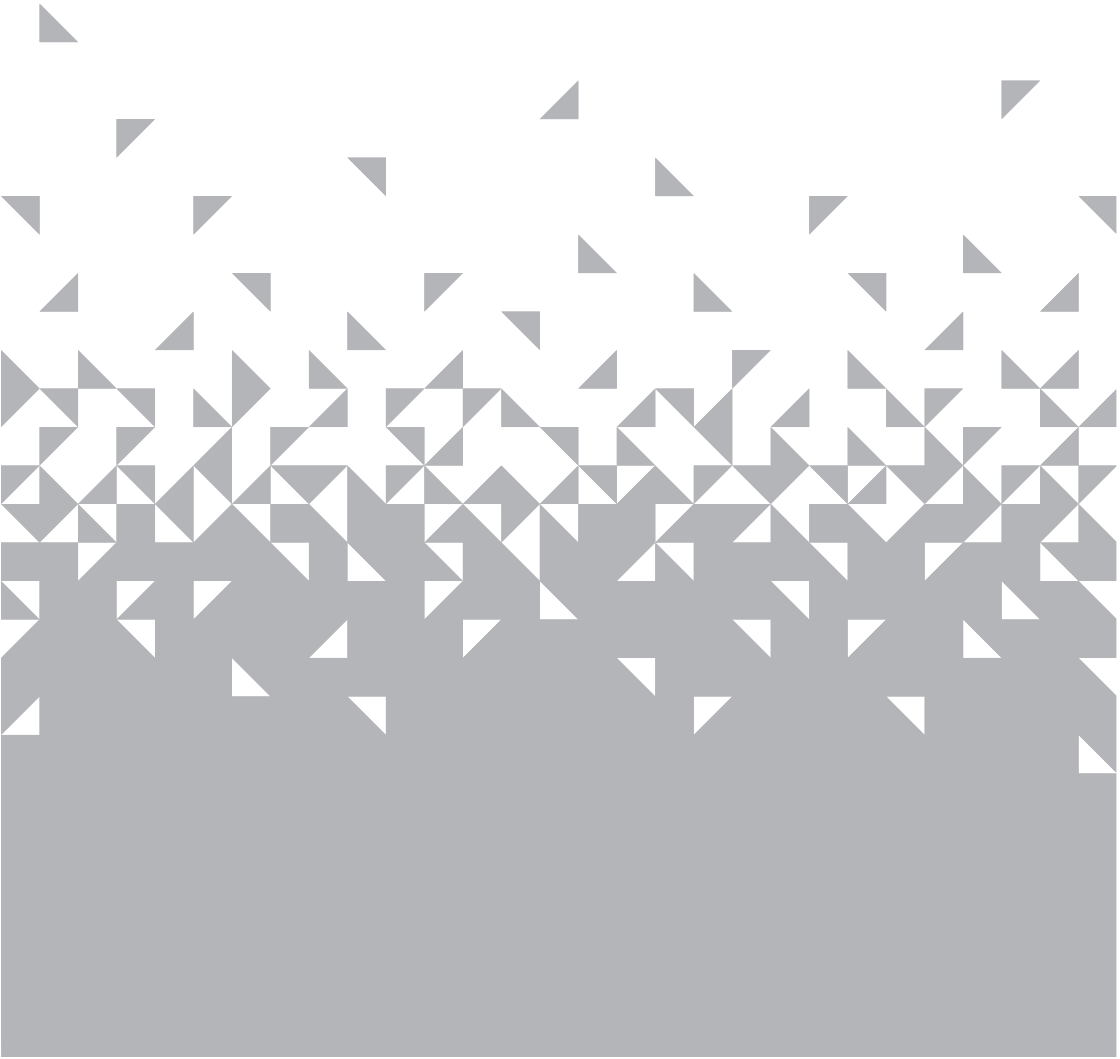

Installing your refrigerator

Bringing it all together

Transportation



Caution: 2 people are required to unpack and handle the appliance, it is recommended that gloves are worn.

- The appliance should be transported only in an upright position. Do not tilt the appliance greater than 45°. The packaging as supplied must be intact during transportation.
- After transporting the appliance, leave it for at least 4 hours before switching on to allow the cooling system to settle. Failure to comply could result in damage to the appliance.
- Do not move the appliance by pulling the door or handle as it may damage your flooring and wall coverings etc.
- Empty any water in the drain tray before moving.
- Make sure that the defrost water pipe at the back of the product is fixed to the plastic evaporating pan on the top of the compressor, to avoid defrost water spillage on the floor.
- Ensure the supply cable is not caught under the appliance during and after moving.
- Carefully remove all packaging materials including the foam base, dispose of correctly.

Installation

- Ensure sufficient spacing is provided for the appliance to be installed. Leave space on both sides (5cm), back (5cm) and above the appliance (5cm) to ensure proper ventilation.

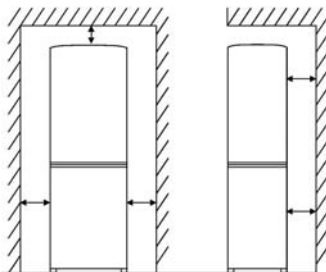

- Do not place the appliance near a heat source or in direct sunlight.
- Do not put any heavy objects on top of the appliance. It will damage the appliance.

- Do not install the appliance in moist and wet place.

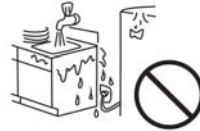

- Adjust the feet at front to level the appliance. It should be installed on a smooth surface to avoid excessive vibration and noise.
- Refer to section "Care and Maintenance" to prepare your appliance for use.
- Each appliance has a climate class (shown on the rating plate) where it indicates the temperature range of the appliance operation in place. The appliance may not work properly if it is left for a long period at a temperature outside the specified range.
 - extended temperature (SN): 'this refrigerating appliance is intended to be used at ambient temperatures ranging from 10 °C to 32 °C (from 50°F to 90°F)';
 - temperate (N): 'this refrigerating appliance is intended to be used at ambient temperatures ranging from 16 °C to 32 °C (from 61°F to 90°F)';
 - subtropical (ST): 'this refrigerating appliance is intended to be used at ambient temperatures ranging from 16 °C to 38 °C (from 61°F to 100°F)';
 - tropical (T): 'this refrigerating appliance is intended to be used at ambient temperatures ranging from 16 °C to 43 °C (from 61°F to 110°F)'

Installing your refrigerator

Bringing it all together

Installation

Door Reverse



Warning: Remove the main plug before reversing the door. 2 people may be required to reverse the door.

1. Remove the screws (1) holding the top panel (2) to the unit. Remove the top panel.
2. Remove the two screws (3) holding the top hinge (4) (right side) to the frame. Remove the top hinge (4).
3. Lift the door off the middle hinge pin and place it on a non-scratching surface.
4. Remove the two screws (5) holding the middle hinge (6). Remove the middle hinge (6).
5. Lift the lower door off the bottom hinge pin and place it on a non-scratching surface.
6. Remove the two screws (7) holding the bottom hinge (8). Remove the bottom hinge (8).
7. Remove the left front leg (9) and transfer it to the right side.
8. Before replacing the bottom hinge (8), remove the hinge pin (10) and reverse the direction of the hinge (8). Reassemble the bottom hinge (6) on the left hand side using the two screws (7).
9. Refit the hinge pin (10) into the bottom hinge (8).
10. Lower the door onto the bottom hinge pin (10).
11. While holding the lower door in the closed position, reassemble the middle hinge (6) on the left hand side using the two screws (5). Do not tighten the screws (5) until the top of the lower door is level with the counter top.
12. Before replacing the upper hinge (4), remove the hinge pin (11) and reverse the direction of the hinge (4). Refit the hinge pin (11) into the upper hinge (4).
13. Lower the upper door onto the middle hinge pin.
14. While holding the upper door in the closed position, reassemble the upper hinge (4) on the left hand side using the two screws (3). Do not tighten the screws (3) until the top of the upper door is level with the counter top. When put upper door to middle hinge, don't add hinge washer.
15. Refit the top panel (2) using the screws (1).

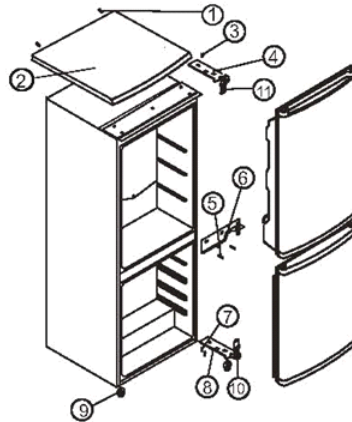

Door opening from left side fig. 1

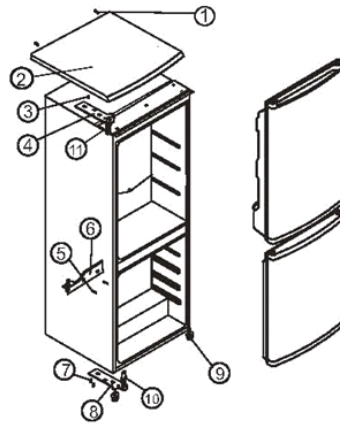

Door opening from right side fig. 2



be tilted more than 45 degree to access the bottom hinge. It is advised to leave the unit for 4 hours to allow the cooling to settle before switch on.

Levelling the appliance

1. Rotate feet clockwise to heighten.
2. Rotate feet anti clockwise to lower.

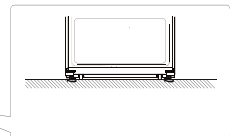

If you require any technical guidance or find that your product is not operating as intended, a simple solution can often be found in the **Troubleshooting** section of these instructions.

Installing your refrigerator

Bringing it all together

Electrical connection



Any electrical work that is required to install this appliance **MUST** be carried out by a qualified electrician.



Warning: THIS APPLIANCE MUST BE EARTHED

Before making any electrical connections, ensure that:

- Electrical safety is only guaranteed when the earth system of your house is in accordance with the related local regulations.
- Do not damage the refrigerant circuit.
- Do not bend, stretch or pull the supply cable to avoid electric shock.
- Do not use electrical appliances inside the food storage compartments of the appliance, unless they are of the type recommended by the manufacturer.
- Ensure the power socket is suitable for the maximum power of the machine (fuses in the power circuit must be 13 amp).
- The supply voltage should be the same as that indicated in the technical specifications and the appliance rating plate.
- The appliance should be earthed and in compliance with the applicable law.
- When installed, the power socket must be within easy reach.
- If the socket outlets in your home are not suitable for the plug supplied with this unit check with a qualified electrician for replacement.
- To avoid the risk of overloading your plug socket, do not use adapters, multiple connectors or extension cables.
- The appliance must be connected to a 220-240 volt 50Hz AC supply by means of a three pin socket, suitably earthed and protected by a 13 amp fuse.
- Should the fuse need to be replaced, a 13 amp fuse approved to BS1362 must be used.
- The plug contains a removable fuse cover that must be refitted when the fuse is replaced. If the fuse cover is lost or damaged, the plug must not be used until a replacement cover has been fitted or the plug is replaced.
- A damaged plug should be cut off as close to the plug body as possible, the fuse should be removed and the plug disposed of safely.

Plug replacement (UK & Ireland only)

Should you need to replace the plug; the wires in the power cable are coloured in the following way:

Blue Neutral 'N'

Brown Live 'L'

Green & Yellow Earth 'E'

As the colours of the wires in the power cable may not correspond with the coloured markings identifying the terminals in your plug, and proceed as follows:

The green & yellow wire must be connected to the terminal in the plug that is marked with the letter E or by the earth symbol.

The blue wire must be connected to the terminal that is marked with the letter N.

The brown wire must be connected to the terminal that is marked with the letter L.

If the power supply cord is damaged, it must be replaced by the manufacturer or its service agent or a similar qualified person in order to avoid a hazard.

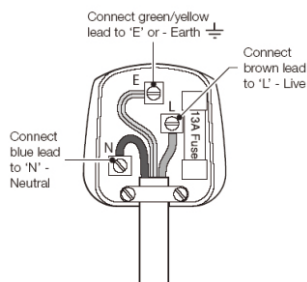



Using your refrigerator 4



Using your refrigerator

Getting the most from your appliance

Final checks before operating the appliance

1. Good air circulation around the appliance positioned.
2. The feet have been adjusted for perfect leveling.
3. Clean the compartment per recommendation in section "Care and Maintenance".
4. Plug in the appliance and interior light will come on when the door is open.



The compressor starts up and in operation may produce some background noise and it is normal, this is not a defect.

Using your appliance



1. Temperature adjustment

- The compartment temperature can be set by the temperature knob between "0" and "7" (coldest setting). We recommend setting the temperature knob midway first.
- To ensure the compartment is maintained at the desired temperature, it is advised to monitor the temperature periodically by a thermometer and adjust the temperature knob accordingly.
- Load the appliance after switch on for a while to allow the temperature reach the desired setting.

2. Storing fresh food

- Use the fridge compartment to store fresh food and drinks.
- Do not exceed the food capacity that the appliance able to handle.
- Do not put warm food to the appliance immediately as it may cause excessive cooling of the compartment.
- Set the temperature knob at medium position for storing fresh food.
- Do not mix already frozen food and fresh food.

3. Storing frozen food

- The freezer compartment is  4 Star rated and suitable for the freezing and storage or pre-frozen food.
- Check the food packaging for  suggestion before storage.

Useful information

The following guidelines and recommendations are suggested to obtain the best results and storage hygiene.

- Frequent door openings can cause internal temperature rise so the door shall be closed as soon as possible after use.
- For hygiene reasons, it is always a good practise to pack, wrap and cover the food before storing.
- Use a polythene bag to store raw meat and place on the lowest shelf. Avoid contact with cooked food to prevent contamination. For safety reason, store raw meat for two to three days only.
- Cooked dishes must be stored in airtight covered containers.
- Food and beverages shall cool to room temperature before storing.
- Most vegetables should be blanched and chilled before freezing.
- Bottles can be placed in the door section.
- Some fruits and vegetables like pineapples, melons, tomatoes, and cucumbers shall be wrapped in polythene bags.
- Do not leave frozen food at room temperature to thaw. You could defrost the food by putting it in the fridge to thaw slowly. Make sure you avoid defrosting food or food juices drip onto other food.

- Do not fill the appliance with too much food, cold air must circulate freely for food to be preserved properly.
- Never re-freeze anything that has thawed out unless you cook it again, to kill off harmful bacterial.
- Never re-freeze thawed shellfish.
- Re-seal packs properly after removing items. This prevents drying or freezer burn' and a build up of frost on any remaining food.
- A high temperature setting may accelerate food to turn bad, hence increase food waste. Therefore for optimum food preservation, a middle temperature setting is generally the most safe and suitable.

Using your refrigerator

Getting the most from your appliance

- **Position different food in different compartments according to the table below.**

Refrigerator compartments	Type of food
Door or balconies of fridge compartment	<ul style="list-style-type: none">• Foods with natural preservatives, such as jams, juices, drinks, condiments.• Do not store perishable foods.
Crisper drawer (salad drawer)	<ul style="list-style-type: none">• Fruits, herbs and vegetables should be placed separately in the crisper bin.• Do not store bananas, onions, potatoes, garlic in the refrigerator.
Fridge shelf – bottom	<ul style="list-style-type: none">• Raw meat, poultry, fish (for short-term storage)
Fridge shelf – top	<ul style="list-style-type: none">• Foods that do not need cooking, such as ready-to-eat foods, deli meats, leftovers.
freezer compartment	<ul style="list-style-type: none">• Foods for long-term storage.• Raw meat, poultry, fish frozen, vegetables, chips, ice cream, frozen fruit, frozen baked goods.

Energy saving tips

- Place your fridge away from direct sunlight, your oven or any other heat sources. Allow 20 cm clear space on both sides and above, and at least 5 cm behind.
- Cover all food stored, and arrange it so that cold air can circulate freely.
- Higher cold setting will use more energy. Do not set to maximum cold if it is not necessary.
- Cool the hot/warm food in the room before putting it into your fridge.
- Frequently open and close door would cause internal temperature rise and it will consume more energy.
- Close the door(s) properly, and make sure the seals and hinges are airtight. Check the seals by putting a sheet of paper between the door and the main body of the fridge. If the paper moves, your seals need replacing.
- Defrost regularly. Accumulated ice layer should not be more than 5 mm thick.
- The pre-set combination of drawers, baskets and shelves have already set in the most efficient use of this product.

Defrosting

- Frost might build up in the unit after it has been used for a period of time. Scrape away the frost using a plastic scraper (not supplied).
- **Do not use a metal or sharp instrument to scrape away the frost, nor should you use any electrical appliances to aid defrosting!**
- Choose a time when the stock of food is low, follow these procedures:
- Take out the food, turn the thermostat to off position and leave the door open. Ideally, the food should be put into another refrigerator. If this is not possible, wrap the food in several sheets of newspaper or large towels and then a thick blanket to keep it cool.
- Place a dry towel at the foot of the unit or drip tray. After the frost has melted, discard the water and clean up. Wring out the soaked towel as needed.
- When defrosting is complete, clean your unit's interior and exterior and restart by turning its thermostat to desired setting.

Using your refrigerator

Getting the most from your appliance

Temperature setting recommendation

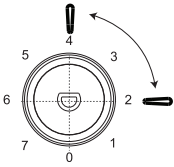
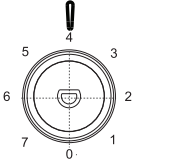
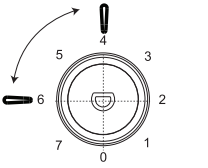
Temperature Setting Recommendation	
Environment Temperature	Fridge compartment
Summer (Above 38°C)	
	Set on 2~4
Normal	
	Set on 4
Winter (Below 16°C)	
	Set on 4~6

Recommended storage time

- Under Recommended setting, the best storage time of fridge is no more than 3 days.
- Under Recommended setting, the best storage time of freezer is no more than 1 month.
- The best storage time may reduce under other settings.

Tips for Storing Foodstuffs

- The quantity of fresh food that can be kept frozen in a specific time period is indicated on the rating plate.
- Load limits are determined by baskets, flaps, drawers, shelves etc. Make sure that these components can still close easily after loading.

If you require any technical guidance or find that your product is not operating as intended, a simple solution can often be found in the **Troubleshooting** section of these instructions.

Care and Maintenance 5

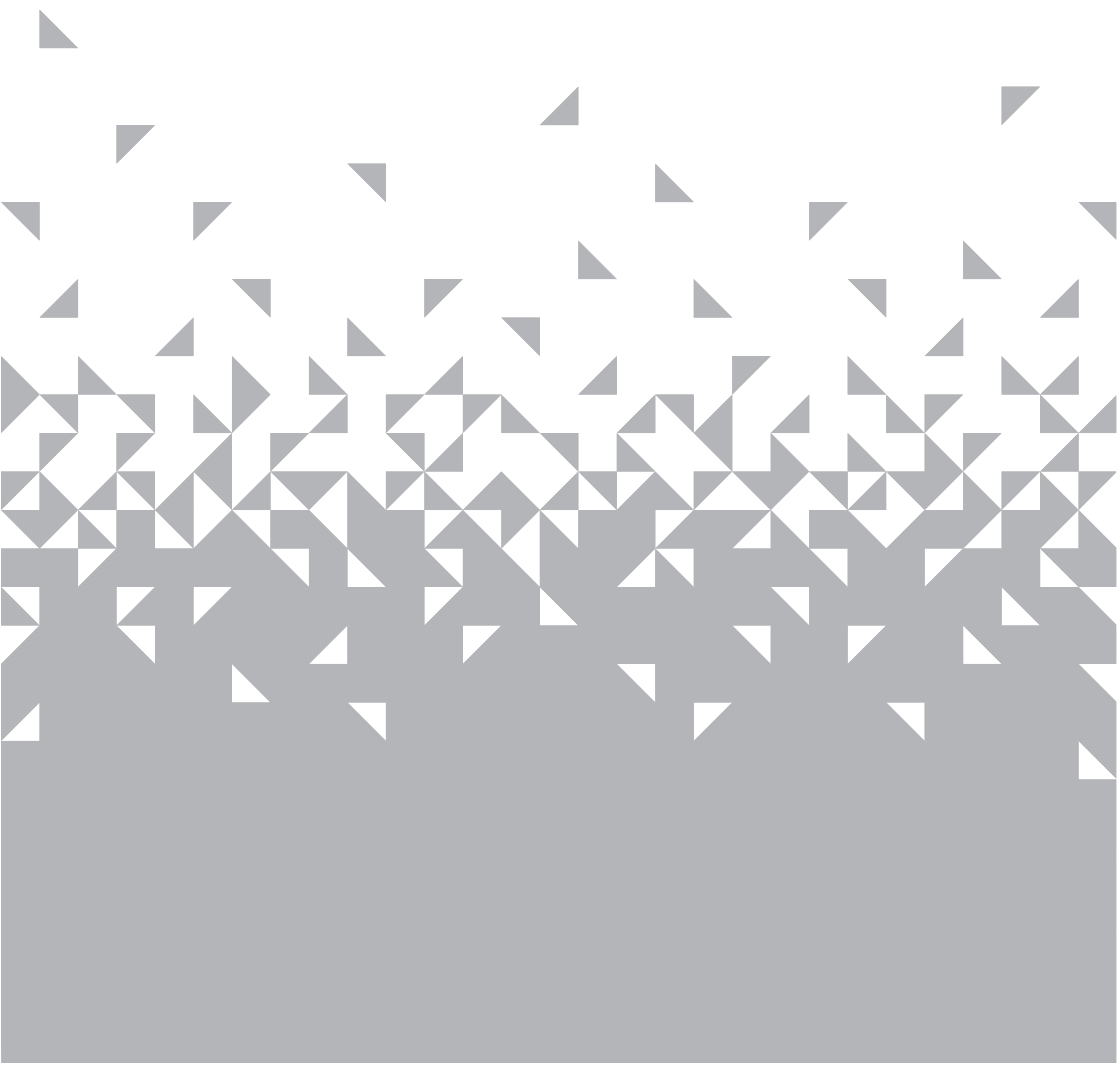

Care and maintenance

Looking after your appliance

General



Important: Always unplug the appliance from the power socket during cleaning and maintenance.

- Never use any sharp instruments or abrasive substances, soap, household cleaner, detergent or wax polish for cleaning.
- Use luke warm water to clean the cabinet of the appliance and wipe it dry.
- Never clean the appliance with flammable fluids. It could cause damage and a fire hazard.
- Clean the exterior of the appliance and door seal with a damp cloth and dry it through.
- Avoid water going into the temperature control box.. Clean with a dry cloth only.
- Clean the condenser (located at the back of the appliance) with a vacuum cleaner. It is suggested to remove the dust every year.
- Shelves are all removable for cleaning purpose.



Important: Care must be taken while cleaning/carrying the appliance not to touch the bottom of the condenser metal wires at the back of the appliance, as this could cause injury to fingers and hands.

Light bulb replacement

This appliance is equipped with a light bulb . It can be used for a long time. If the light bulb is blown, it must be replaced by a qualified person to avoid any hazard. Contact the service agent at 0345 257 7271.

Power failure

In case there is a power failure, you should contact the electricity supply company and take the following actions:

If it is less than 24 hours, keep the doors closed. This will allow the stored food to stay cold as long as possible.

If it lasts more than 24 hours, it is advised to empty the freezer compartment and temporarily store the food in a portable freezer or using artificial ice packs. Try to use up the food which is more easily perishable.

Remarks: A full appliance will stay cold longer than a partially filled one. If ice crystals are still visible on the food, it may be frozen again, although flavour and aroma may be affected. If food is found to be in a poor condition, it is best to throw it away.

Short vacation

There is no need to disconnect the appliance from the mains if you will be away for two to three weeks. Use up the perishable food.

Long vacation

Remove all the food if you are away for three weeks or more. Unplug the appliance and leave the doors open to provide air circulation to prevent odour and mould.

Moving your appliance

Moving

Refer to section “Transportation” under “Installation”

Care and maintenance

Looking after your appliance

Technical Specifications

Model	ME48115FF
Energy efficiency class	E
Energy consumption Kwh/year	165
Net storage volume fresh food (litres)	89
Net storage volume frozen food (litres)	28
Total net storage (litres)	117
Frozen food compartment rating	4star 
Climate class	N
Operating noise level dB(A)	40
Minimum Operation Temperature	16°C
Product Dimension	480mmx500mmx1140mm

The model information can be retrieved using the QR-Code reported in the energy label.

The label also includes the model identifier that can be used to consult the portal of the registry at <https://eprel.ec.europa.eu>

This product contains a light bulb which does not meet the definition of light source/control gear defined in regulation (EU) 2019/2020.

Disposal information



The symbol on the product or its packaging indicates that this product may not be treated as household waste. Instead it should be handed over to the applicable collection point for the recycling of electrical and electronic equipment. By ensuring this product is disposed of correctly, you will help prevent potential negative consequences for the environment and human health, which could otherwise be caused by inappropriate waste handling of this product. For more detailed information about recycling this product, please contact your local council office, your household waste disposal service or the shop where the product was purchased.

Remember : Old fridges must be disposed of carefully - older models contain CFC gases that are harmful - if in doubt , contact your local council for details on how to dispose of an old fridge .

Doors and lids of the refrigeration appliance should be removed before disposal in the landfill, to avoid children or animals getting trapped inside.

If you require any technical guidance or find that your product is not operating as intended, a simple solution can often be found in the **Troubleshooting** section of these instructions.

Product support 6

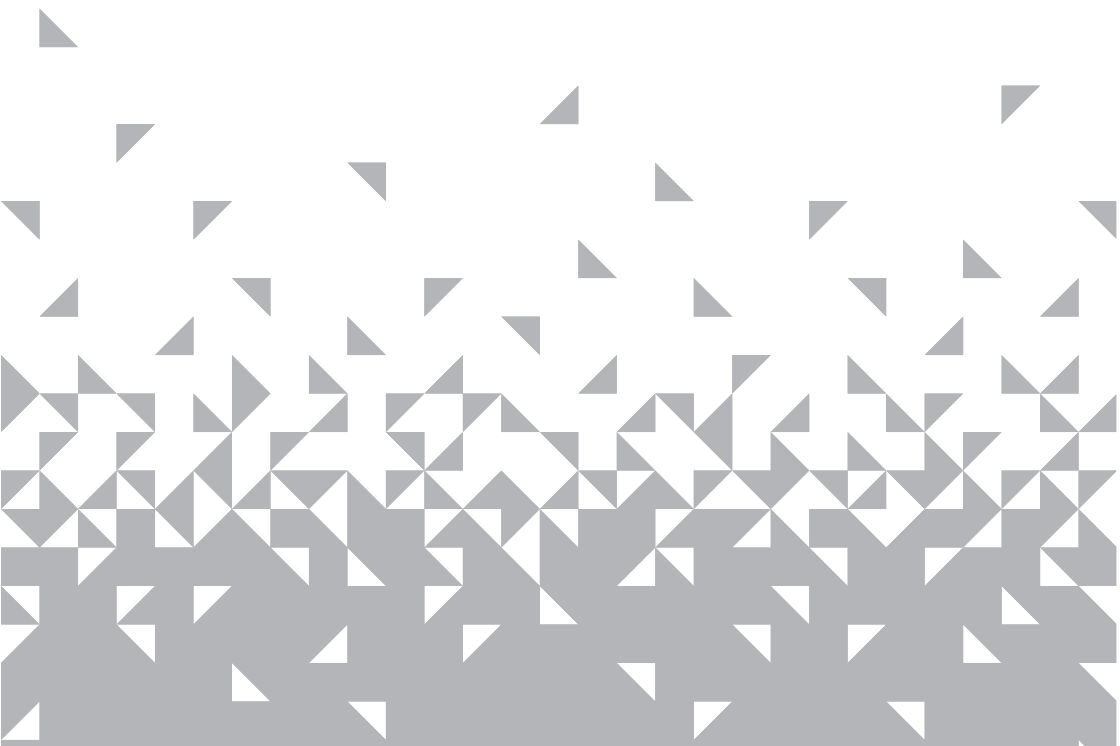

Product support

Help is always at hand

Troubleshooting

If you have a problem with your product, these questions may be able to assist you?

Question- Appliance does not work.

Answer

Appliance is not switched on - Turn on the appliances.

Mains plug is not plugged in or is loose. -Insert mains plug.

Fuse has blown or is defective - Check fuse, replace if necessary.

Socket is defective - Mains malfunctions are to be corrected by an electrician.

Question - Appliance cools too much.

Answer

Temperature is too cold - adjust to a warmer setting.

Question - The food is too warm.

Answer

Temperature is not properly adjusted - adjust to a cooler setting.

Door was open for an extended period - Open the door only as long as necessary.

A large quantity of warm food was placed in the appliance - adjust to a cooler setting.

Cool warm food before placing in the refrigerator.

The appliance is near a heat source - Position the refrigerator away from a heat source.

Question- Interior light does not work.

Answer

If the light bulb is broken, please contact qualified technician.

Question-Heavy build up of frost, possibly also on the door seal.

Answer

Door seal is not air tight - Carefully warm the leaking sections of the door seal with a

hair dryer(not hotter than approx 50 degree). At the same time shape the warmed door seal

by hand such that it sits correctly.

Question - Water on the floor or on storage shelves.

Answer

Water drain hole is blocked - Remove food residue or ice from the entrance of the drain hole.

Question - Appliance is making unusual noises

Answers

Appliance is not level - Readjust the front levelling feet.

Appliance is in contact with wall or other objects. - Push appliance away a short distance

A part at the back of the appliance, e.g. a tube, is in contact with another appliance part or

wall - - Gently bend this part away carefully if necessary

Product support

Help is always at hand

Help and assistance

If you require any technical guidance or find that your refrigerator is not operating as intended, a simple solution can often be found in the **Troubleshooting** section of these instruction or online at www.bush-support.com

If you still require further assistance, call one of our experts on **0345 257 7271**. To help give us give you a fast and efficient service please have the following information ready.

Model Ref.

You can find these on the rating plate-a small information panel (usually a sticker or metal plate) on the rear of your appliance

Serial number

Date of purchase

This will be shown on your receipt

Local call rates applies*

Line open 8am-7pm Monday to Saturday and 10am-4pm Sunday

*Calls to Bush enquiry lines may attract a charge and set up fee from residential lines depending on your call plan/tariff. Mobile and other providers costs may vary, see www.bt.com/pricing for details.

For security and training purpose, telephone calls to and from customer service centres maybe recorded and monitored.Call from Republic of Ireland will attract international call charges.



This appliance complies with the following EEC directives:
2014/35/EEC Low voltage directive
2014/30/EU EMC directive

Product support

Help is always at hand

BUSH

Call us now and activate your 12 month guarantee

Thank you for choosing Bush. Your new product is guaranteed against faults and breakdowns for 12 months. Don't forget to register it with us today so we can provide you with our best possible after-sale service and useful updates.

www.bushregistration.co.uk

FREEPHONE*

0800 597 8548

Lines are open 8am-8pm, 365 days a year. *Call may be recorded and monitored.

Your Bush Guarantee

This product is guaranteed for twelve months from the date of original purchase. Any defect that arises due to faulty materials or workmanship will be repaired free of charge (or if applicable the product will be replaced or the purchase price refunded) where possible during this period by the dealer from who your purchased unit.

The guarantee is subject to the following provisions:

- The guarantee does not cover accidental damage, misuse cabinet parts, knobs or consumable items.
- The product must be correctly installed and operated in accordance with the instructions contained in the manual
- It must be used solely for domestic purposes. The guarantee will be rendered invalid if the product is re-sold or has been damaged by inexpert repair.
- Specifications are subject to change without notice.
- Bush disclaim any liability for loss or damage arising from the breakdown of the product
- This guarantee is in addition to and does not diminish your statutory or legal rights

Important Data Protection Information

To find out how we and Domestic & General Insurance Plc use your data please refer to the guarantee registration material or visit www.bushregistration.co.uk

Product support

Help is always at hand

Spare Parts Supply

To order spare parts, please contact our customer helpline: 0345 257 7271. The original spare parts for some specific components are available for a minimum of 7 or 10 years, based on the type of component, from the placing on the market of the last unit of the model.

BUSH

A decorative background pattern consisting of numerous grey triangles of varying sizes and orientations, scattered across the page. The triangles are more densely packed in the lower half of the page, creating a textured effect.

Produced in China for
Argos Limited, London, EC1N 2HT, UK.
Argos (N.I.) Ltd., Forestside Shopping Centre,
Upper Galwally, Belfast, BT8 6FX, UK.

Contact

www.bush-support.com
Helpline:0345 257 7271

CKBSH-P03