

DELUXE TWO TIER SHOE CABINET

Thank you for purchasing the SHOE CABINET. Please read the instructions carefully to ensure safe operation of the product.

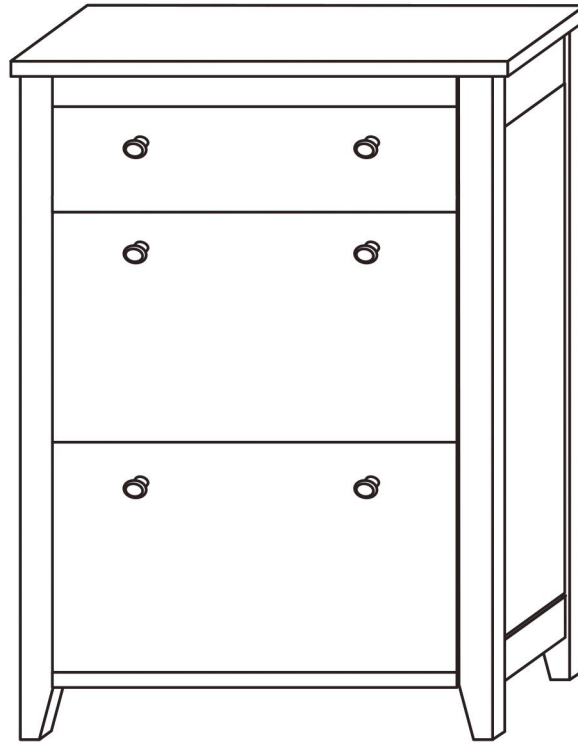

Size:W80XD25XH108cm
Colour:WHITE/GREY
Finish:Painted

PLEASE READ this sheet prior to assembly to familiarise yourself with the various stages of construction.

Carefully open the pack supplied and check the contents against the parts and fittings check list. Do not destroy any of the packaging until you are certain that you have all the necessary parts for the assembly.

CAUTION: There are small components used in the construction of this unit. These loose items should be kept away from young children whilst assembling your unit to avoid the danger of choking hazards.

Tools Required

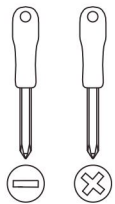

(NOT INCLUDED)

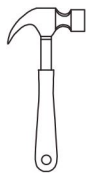

(NOT INCLUDED)

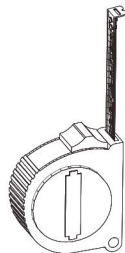

(NOT INCLUDED)

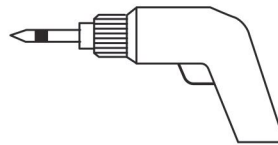

(NOT INCLUDED)



2 Person Build



1 Hour
Set Up

DELUXE TWO TIER SHOE CABINET

IMPORTANT - READ CAREFULLY - RETAIN THESE INSTRUCTIONS FOR FUTURE REFERENCE.

INFORMATION

- This product is designed to hold 20Kg in total, spread evenly over the whole unit. Do not exceed this weight.
- Due to the size of this product we recommend that it is assembled in the room intended for use.
- When you are ready to start, make sure that you have the right tools, plenty of space and a clean, dry area for assembly.
- Unwrap all packaging materials and place the components on top of the carton box or on a clean floor to prevent it from scratching.
- Check the pack and make sure you have all the parts listed.
- Ensure that this product is fully assembled and secured as illustrated before use.
- Check all screws or bolts are tightened and inspect regularly.
- This product should only be used on firm, level ground.
- Keep small parts out of reach of children.
- Make sure the legs remain in contact with the ground.
- Tools are not included.

WARNINGS

- DO NOT use power tools to construct this product.
- DO NOT over tighten screws or bolts.
- DO NOT use this product if parts are missing, damaged or worn.
- DO NOT sit or stand on the product.
- It is essential that this unit is fixed to a wall with the fixings provided.
- We recommend the use of the wall fixing provided for safety reasons. N.B. if in doubt pls consult a qualified tradesperson. **Warning:** Always ensure the area to be drilled is free from hidden electrical wires, water and gas pipes.

CARE INFORMATION

- Never use scourers, abrasives or chemical cleaners
- To clean wipe with a sponge and warm soapy water. Do not use solvent based cleaners or detergents as they can bleach or damage the product





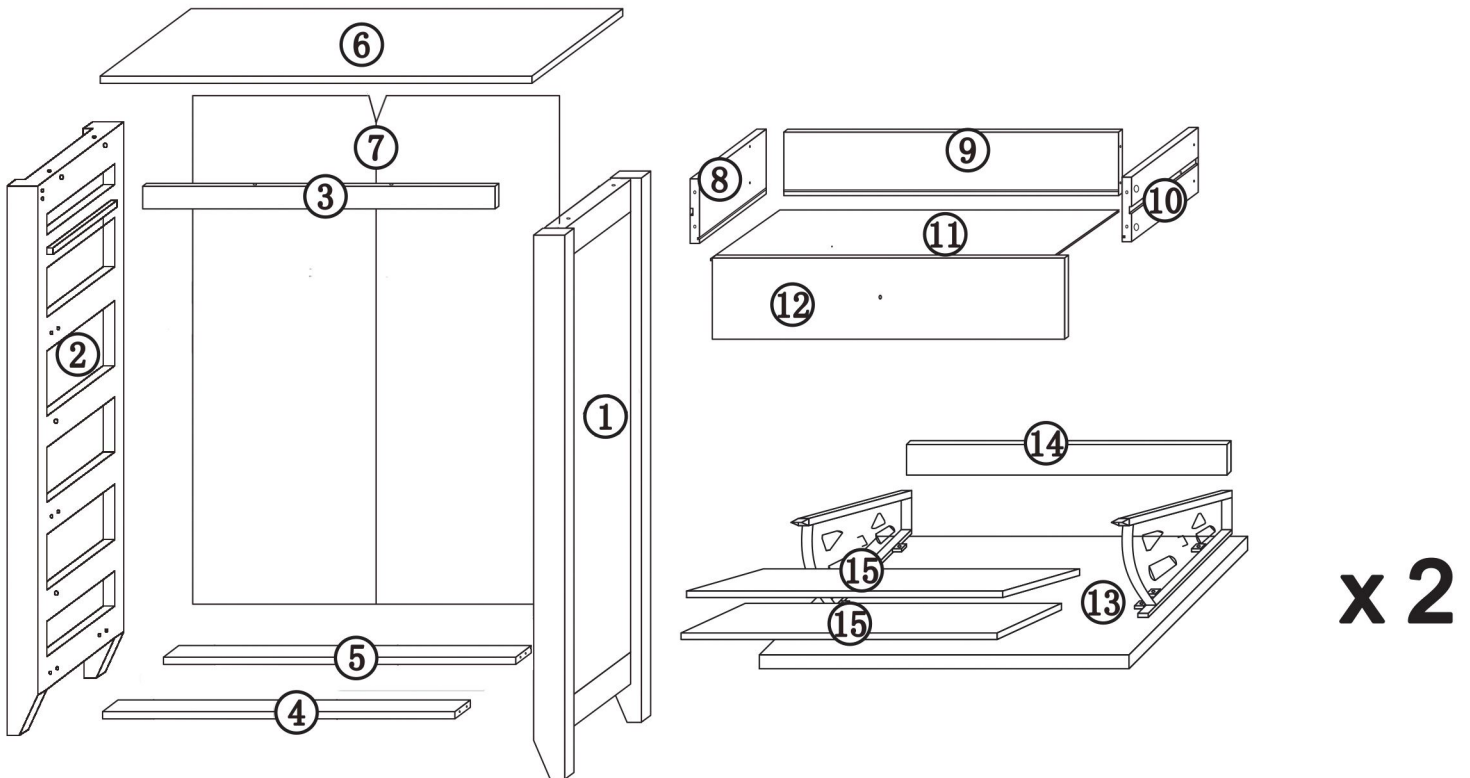





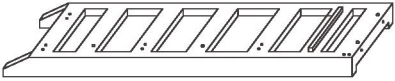
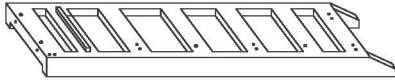

DELUXE TWO TIER SHOE CABINET

Please check the pack contents before assembling the product. If any components are missing, please contact your retailer. The fittings pack contains small items that should be kept away from small children.

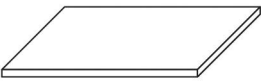

DELUXE TWO TIER SHOE CABINET

PARTS

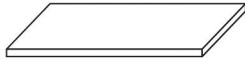
<p>1</p> 	<p>2</p> 	<p>3</p> 
<p>Description:RIGHT SIDE PANEL QTY:1 PC Dimension3:1055X240X50MM</p>	<p>Description:LEFT SIDE PANEL QTY:1 PC Dimension:1055X240X50MM</p>	<p>Description:TOP CROSS BAR(BACK) QTY:1 PC Dimension:640X50X15MM</p>
<p>4</p> 	<p>5</p> 	<p>6</p> 
<p>Description:MIDDLE CROSS BAR(BACK) QTY:1 PC Dimension:640X50X15MM</p>	<p>Description:BOTTOM PANEL QTY:1 PC Dimension:640X50X15MM</p>	<p>Description:TOP PANEL QTY:1 PC Dimension:800X250X25MM</p>
<p>7</p> 	<p>8</p> 	<p>9</p> 
<p>Description:BACK PANEL QTY:1 PC Dimension:975X657X3MM</p>	<p>Description:DRAWER LEFT HAND SIDE PANEL QTY:1 PC Dimension:190X115X12MM</p>	<p>Description:DRAWER BACK QTY:1 PC Dimension:610X115X12MM</p>
<p>10</p> 	<p>11</p> 	<p>12</p> 
<p>Description:DRAWER RIGHT HAND SIDE PANEL QTY:1 PC Dimension:190X115X12MM</p>	<p>Description:DRAWER BOTTOM QTY:1 PC Dimension:620X186X3MM</p>	<p>Description:DRAWER FRONT QTY:1 PC Dimension: 635X151X15MM</p>
<p>13</p> 	<p>14</p> 	<p>15</p> 
<p>Description:DOOR PANEL QTY:2 PCS Dimension: 635X364X12MM</p>	<p>Description:CROSS BAR QTY:2 PCS Dimension:627X85X12MM</p>	<p>Description:SHELF QTY:4 PCS Dimension:627X14X12MM</p>

DELUXE TWO TIER SHOE CABINET

Fixings (to scale)

Ref	Dimensions	Qty
A	CAM BOLT (6X35MM)	16
B	CAM LOCK (15X10MM)	16
C	SCREW (3X12MM)	22
D	DOWEL (6X30MM)	6
E	SCREW (4X30MM)	16
F	SCREW (3.5X12MM)	12
G	SCREW (4X16MM)	4

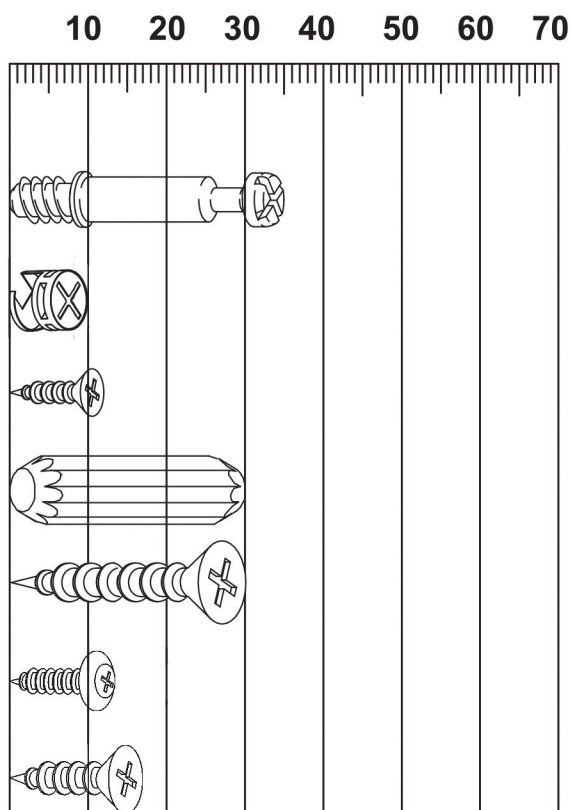

Fixing(not to scale)

H	WALL FIXING	1
I	DOOR STOPPER	4
J	OUTER GROMMET	4
K	LEFT PLASTIC BRACKET	2
L	RIGHT PLASTIC BRACKET	2
M	INNER GROMMET	4
N	HANDLE	6
O	DRAWER STOPPER	2

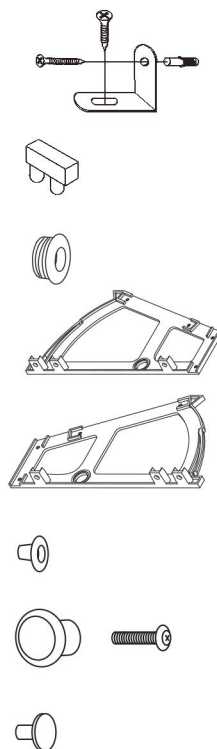

CAUTION: There are many small components used in the construction of this product. Please keep these components away from young children whilst assembling this product. If you keep the fittings in a bowl during assembly you will be less likely to lose them!

DELUXE TWO TIER SHOE CABINET

General Hints and Tips Don't screw too deep

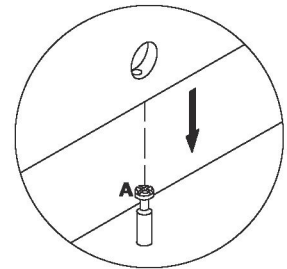
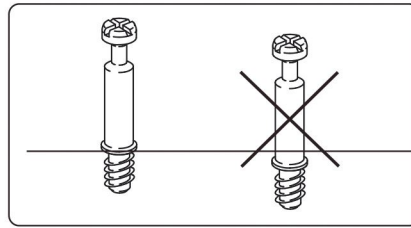
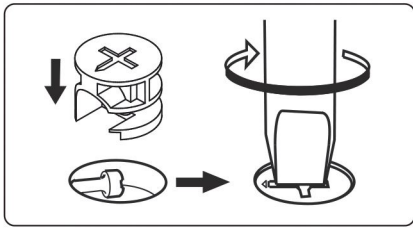

Layout Parts on Soft Surface

Layout all part on a soft surface i.e. Rug, carpet or packaging carton

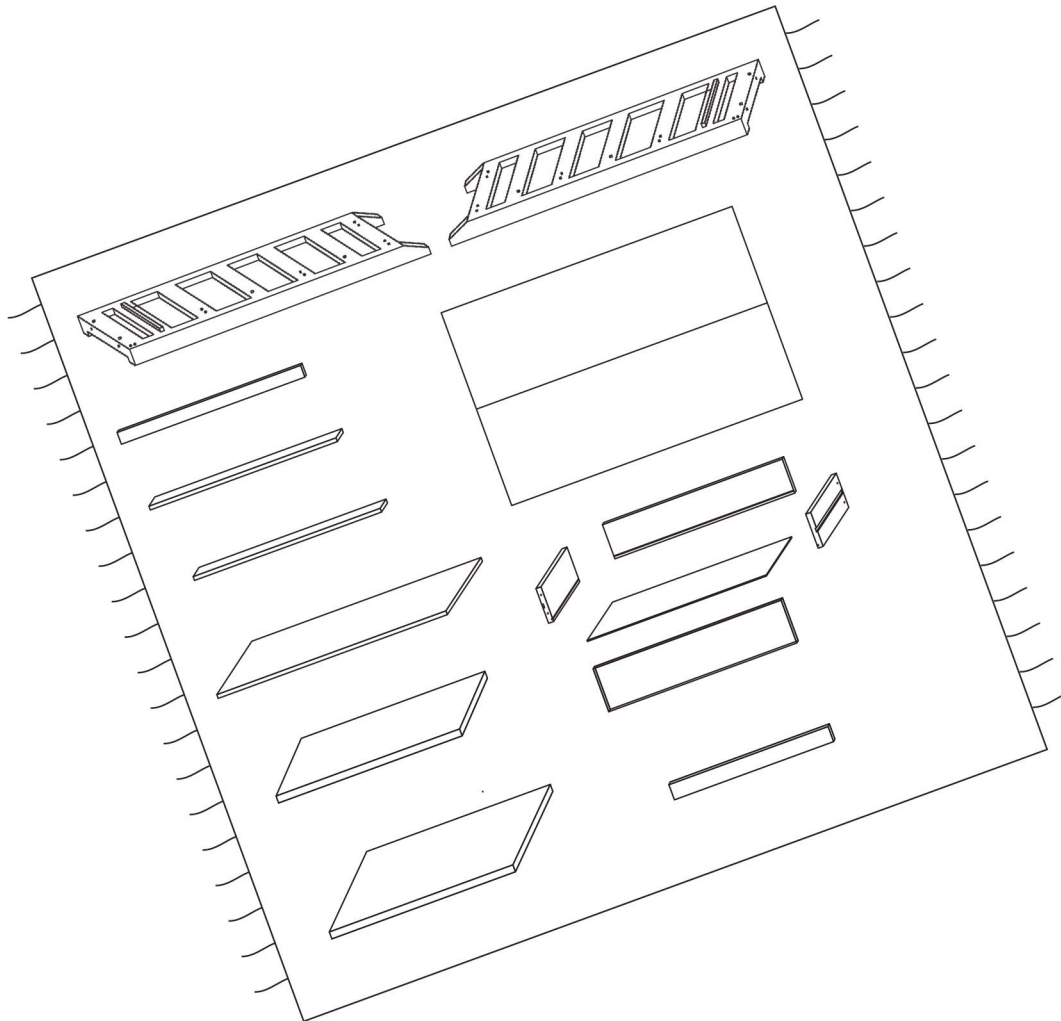

DELUXE TWO TIER SHOE CABINET

STEP 1	PARTS REQUIRED
	<p>1: RIGHT SIDE PANEL X1 2: LEFT SIDE PANEL X1</p> <p>A: CAM BOLT X 6 I: DOOR STOPPER X 4 J: OUTER GROMMET X 4</p>

STEP 2	PARTS REQUIRED
	<p>13: DOOR PANEL X2 14: CROSS BAR X2 15: SHELF X2</p> <p>F: SCREWS X12 E: SCREWS X8 K: LEFT PLASTIC BRACKET X2 L: RIGHT PLASTIC BRACKET X2 N: HANDLE X4</p>

DELUXE TWO TIER SHOE CABINET

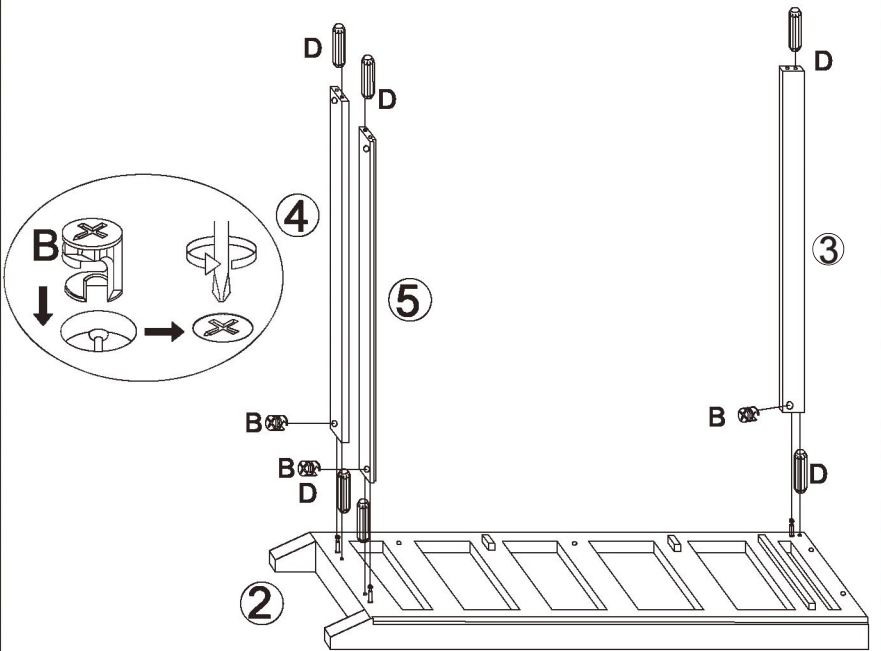
STEP 3	PARTS REQUIRED
 <p data-bbox="212 958 1059 992">Ensure the cam lock is lined up with the cam bolt when fixing.</p>	<p data-bbox="1086 360 1394 479">2: LEFT SIDE PANEL X1 3: TOP CROSS BAR (BACK) X1 4: MIDDLE CROSS BAR (BACK) X1 5: BOTTOM PANEL X1</p> <p data-bbox="1086 510 1241 568">B: CAM LOCK X3 D: DOWEL X6</p>

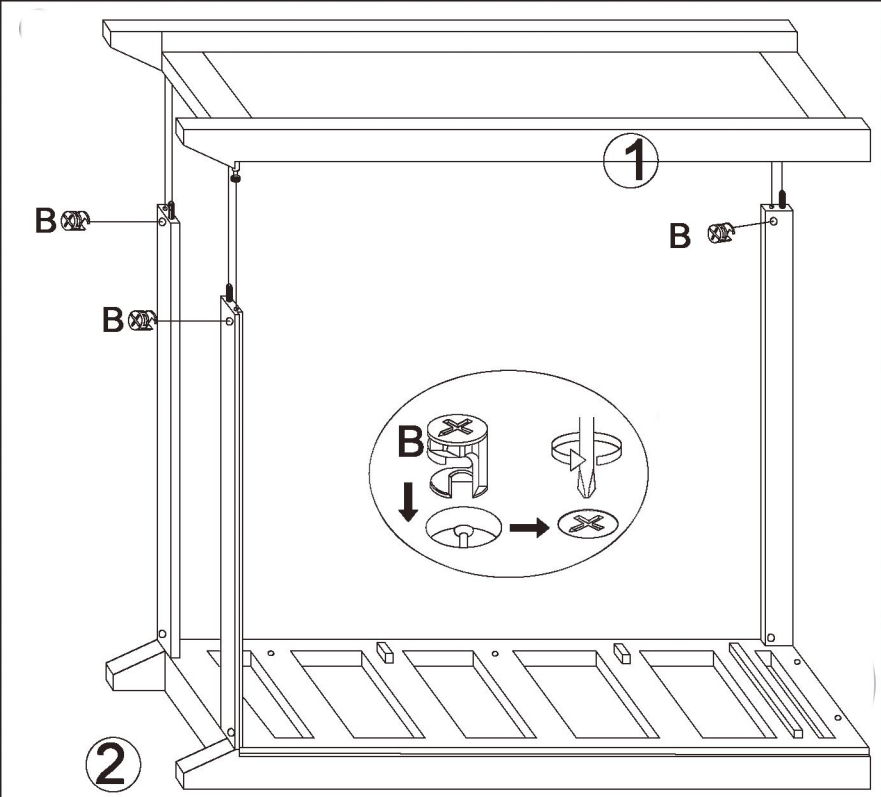
STEP 4	PARTS REQUIRED
 <p data-bbox="217 1944 1066 1977">Ensure the cam lock is lined up with the cam bolt when fixing.</p>	<p data-bbox="1094 1155 1339 1189">1: RIGHT SIDE PANEL X1</p> <p data-bbox="1094 1249 1257 1283">B: CAM LOCK X 3</p>

DELUXE TWO TIER SHOE CABINET

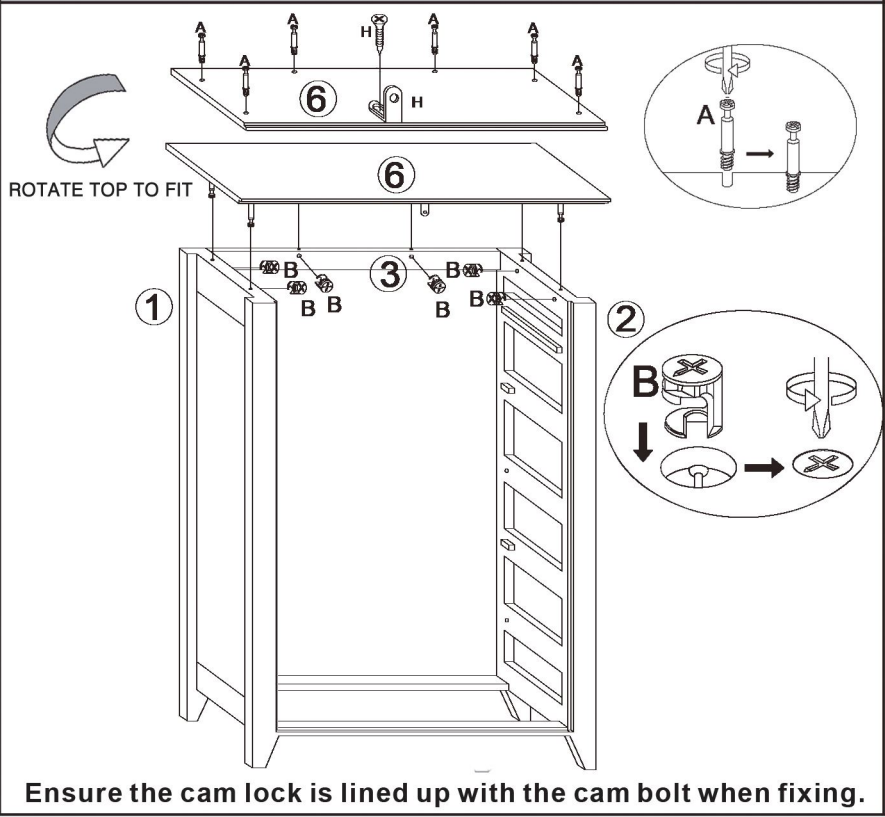
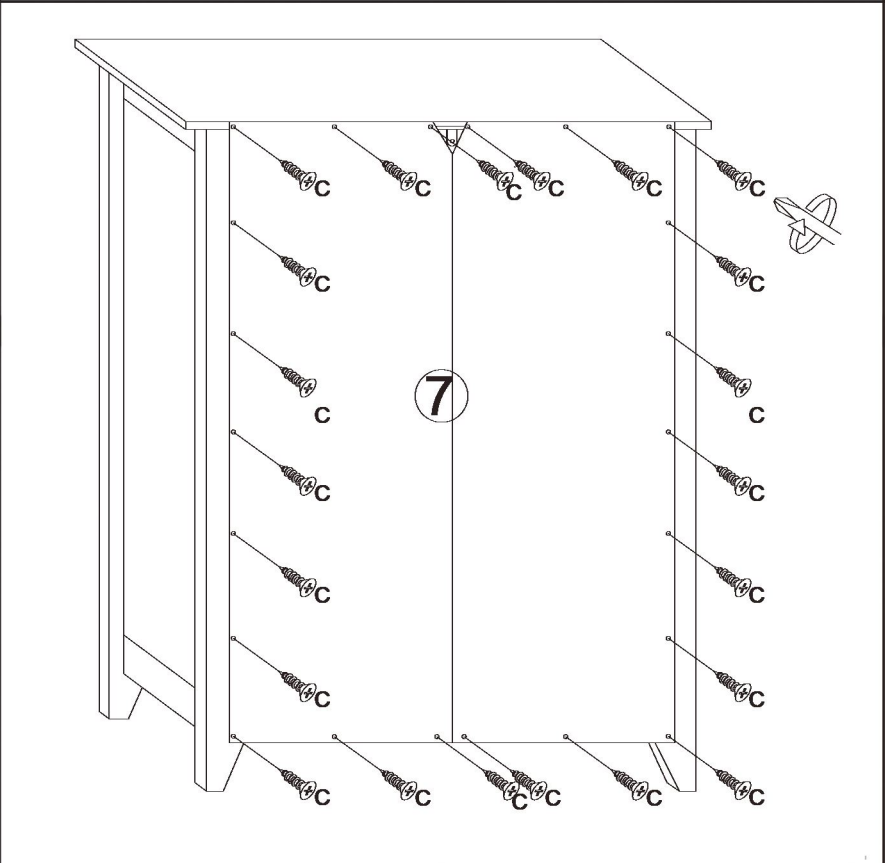
STEP 5	PARTS REQUIRED
 <p>ROTATE TOP TO FIT</p> <p>6: TOP PANEL X1 A: CAM BOLT X6 B: CAM LOCK X6 H: WALL FIXING X1</p> <p>Ensure the cam lock is lined up with the cam bolt when fixing.</p>	<p>6: TOP PANEL X1</p> <p>A: CAM BOLT X6</p> <p>B: CAM LOCK X6</p> <p>H: WALL FIXING X1</p>
STEP 6	PARTS REQUIRED
 <p>7: BACK PANEL X1</p> <p>C: SCREW X 22</p>	<p>7: BACK PANEL X1</p> <p>C: SCREW X 22</p>

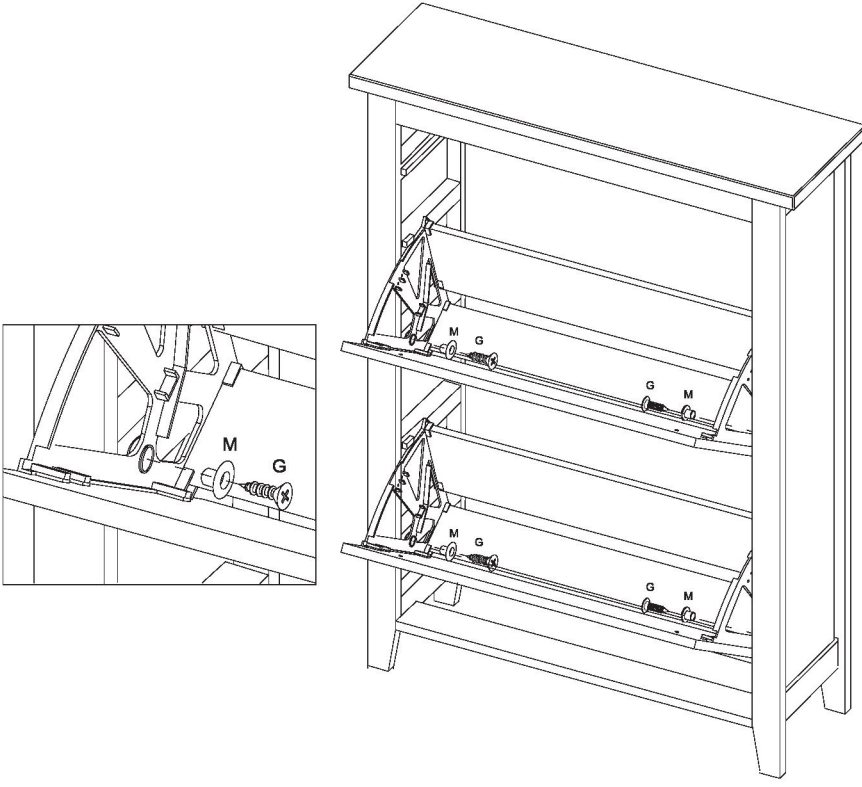

DELUXE TWO TIER SHOE CABINET

STEP 7	PARTS REQUIRED
	<p>G: SCREWS X 4 M: INNER GROMMET X 4</p>

STEP 8	PARTS REQUIRED
	<p>15: SHELF X 2</p>

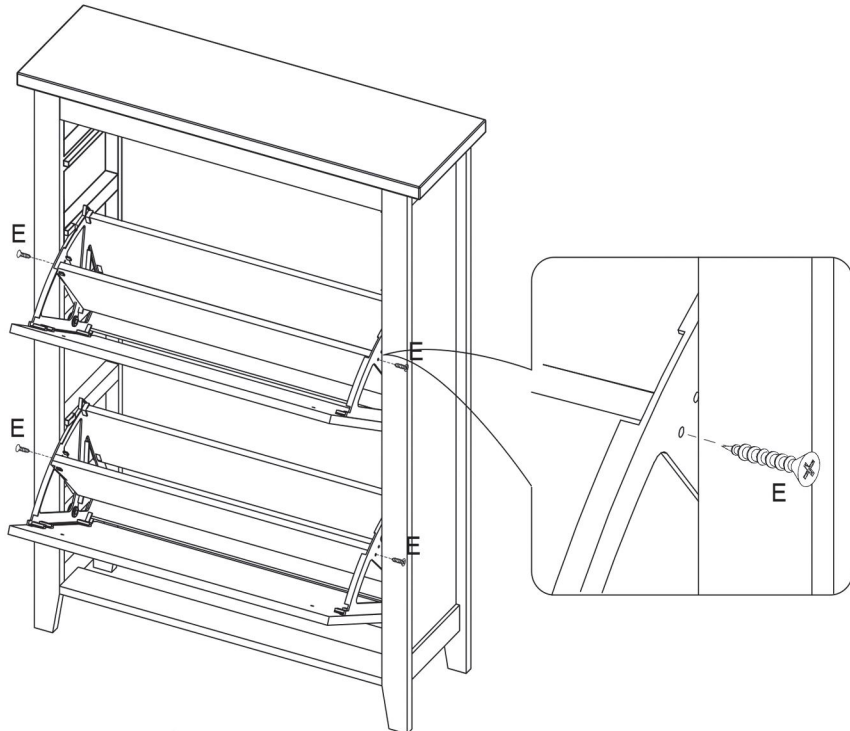
DELUXE TWO TIER SHOE CABINET

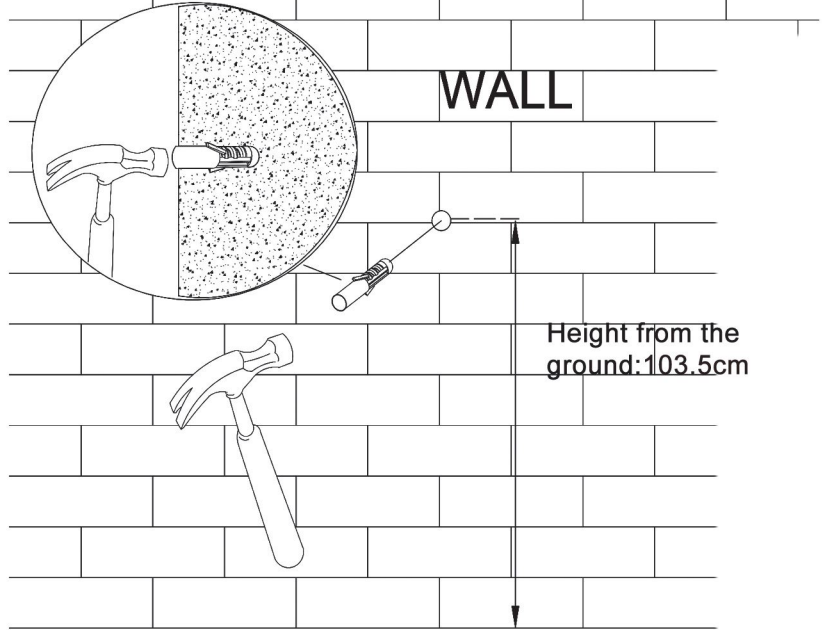
STEP 9	PARTS REQUIRED
	E:SCREWS X 4

STEP 10	PARTS REQUIRED
 <p data-bbox="654 1332 790 1377">WALL</p> <p data-bbox="758 1579 965 1646">Height from the ground:103.5cm</p> <p data-bbox="375 1904 901 1982"> Warning: Always ensure the area to be drilled is free from hidden electrical wires, water and gas pipes.</p>	H:WALL FIXING X 1

DELUXE TWO TIER SHOE CABINET

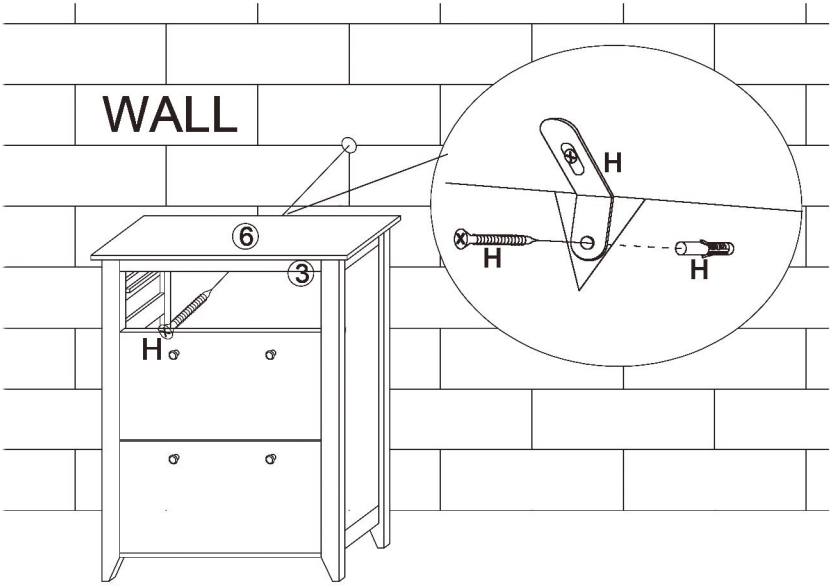
STEP 11	PARTS REQUIRED
	<p>H:WALL FIXING X1</p>

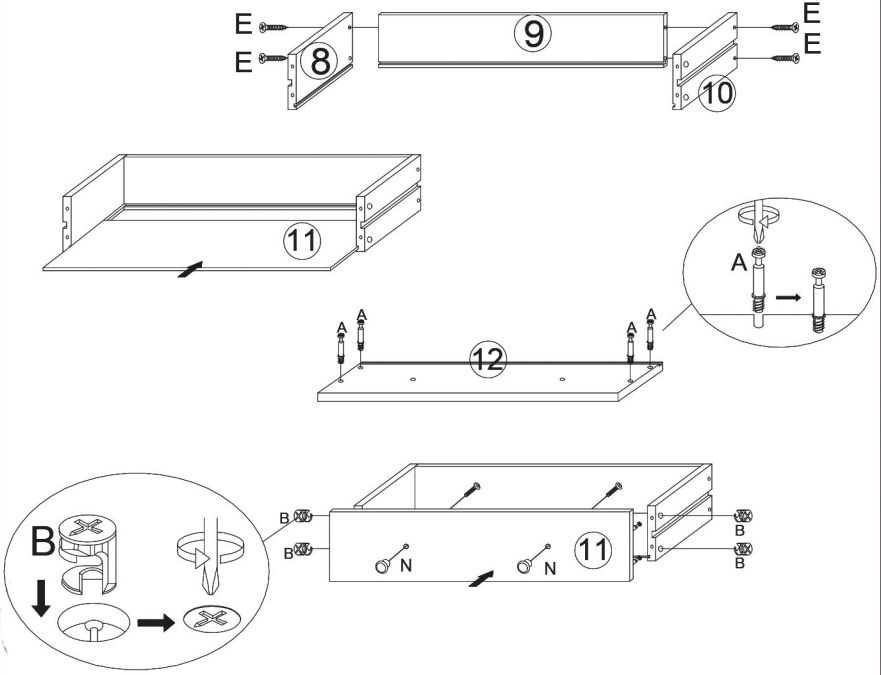
STEP 12	PARTS REQUIRED
 <p>Ensure the cam lock is lined up with the cam bolt when fixing.</p>	<p>8:DRAWER LEFT SIDE PANEL X1 9:DRAWER BACK X1 10:DRAWER RIGHT SIDE PANEL X1 11: DRAWER BOTTOM X1 12:DRAWER FRONT X1</p> <p>A:CAM BOLT X 4 B:CAM LOCK X 4 E: SCREWS X 4 N: HANDLE X 2</p>

DELUXE TWO TIER SHOE CABINET

STEP 13

PARTS REQUIRED

O:DRAWER STOPPER X2

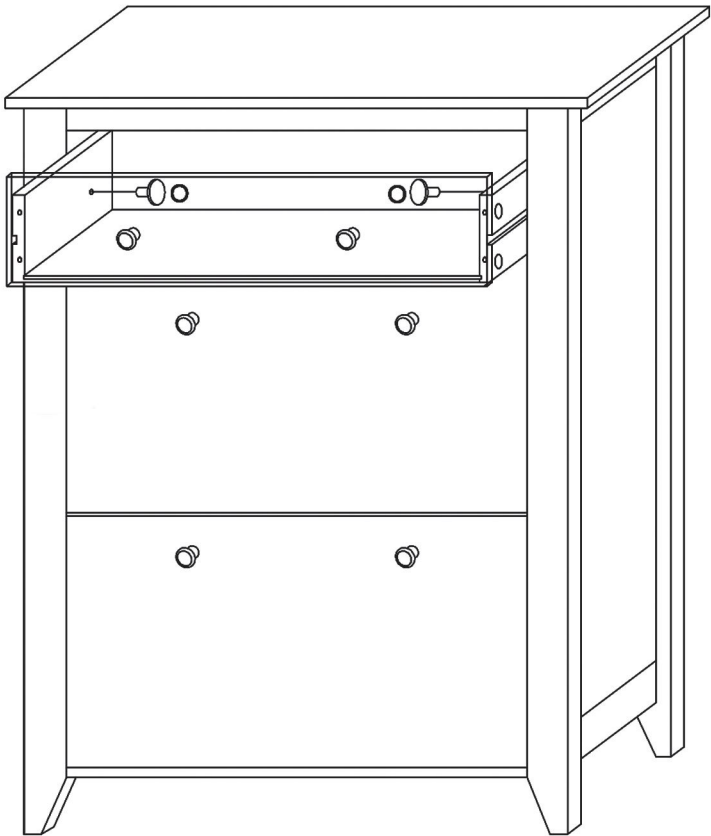

DELUXE TWO TIER SHOE CABINET

Complete Assembly

Your **SHOE CABINET** is now completely assembled.

Periodically check to ensure that the components are in their proper position, free from damage.

Also, make sure the connectors are tight and secure.

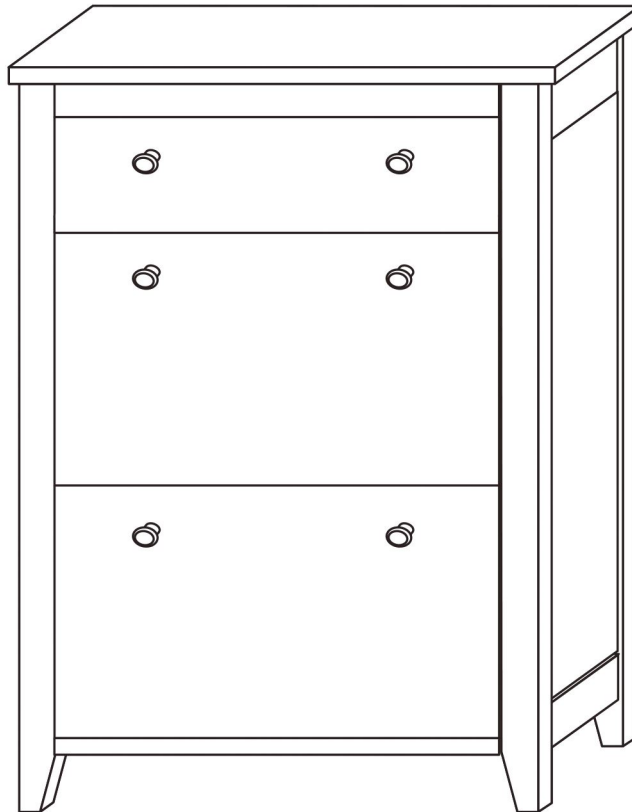

Keep instructions for future reference

