

BUSH

Instruction manual

WMSAA1214W



You'll soon be enjoying your new washing machine.

It all begins here, with your instructions. Don't worry, there's nothing too technical coming up. Just simple, step-by-step guidance to get you up and running quickly. Sound good? Then let's get started.

Help and Guidance

We're here to help you get the most from your washing machine. Should you require any guidance, a simple solution can often be found online at:

www.bush-support.com

If you still require further assistance, call one of our experts on **0345 257 7271**.

Contents

1	Safety information		
	Safety information	6	
2	Getting to know your washing machine		
	Ready? Let's begin	10	
	Accessories	12	
3	Installing your washing machine		
	Installation requirements	14	
	Unpacking	14	
	Connections (electrical, water, gas)	15	
4	Functions		
	Functions	18	
5	Using your washing machine		
	First use of washing machine	24	
	Guidelines of washing detergent	26	
6	Care and Maintenance		
	Cleaning	30	
	Maintenance actions	30	
	Technical specifications	32	
7	Product support		
	Troubleshooting		38
	Help and assistance		39
	Declaration of conformance to product standards		40
	Disposal		40

Safety information

1





Safety information

Important - Please read these instructions fully before installing or operating

- Do not connect the machine if it has been damaged in transit.
- If the supply cord is damaged, it must be replaced by the manufacturer, its service agent or similarly qualified persons in order to avoid a hazard.
- The new hose-sets supplied with the appliance are to be used and the old hose-sets should not be reused.
- This washing machine is for indoor use only and must be protected from rain, moisture and extreme temperature variations. Never expose the machine to intense heat or humidity.
- This washing machine is designed for household use only. Do not use the machine for industrial and commercial use, or any other purpose.
- The openings must not be obstructed by a carpet.
- This appliance can be used by children aged from 8 years and above and persons with reduced physical, sensory or mental capabilities or lack of experience and knowledge if they have been given supervision or instruction concerning use of the appliance in a safe way and understand the hazards involved. Children shall not play with the appliance. Cleaning and user maintenance shall not be made by children without supervision.
- Pull out its plug from the power socket before cleaning or maintenance.
- Make sure that all pockets are emptied.
- This machine must be positioned on a firm level base.
- Do not splash water on the machine. It may cause electrical parts to fail and result in an electric shock.
- Sharp and rigid items such as a coin, brooch, nail, screw or stone etc. may cause serious damages to this machine.
- Pull out its plug and cut off water supply after the operation.
- Please check whether the water inside the drum has been drained before opening its door. Please do not open the door if there is any water visible.
- Check machine before every operation to ensure pets and children are not in the machine.
- Glass door may be very hot during the operation. Keep children and pets far away from the machine during the operation.
- Take care that power voltage and frequency shall be identical to those required by washing machine.
- Do not use any socket with rated current less than that required by washing machine. Never pull out power plug with wet hand.

If you require any technical guidance or find that your product is not operating as intended, a simple solution can often be found in the **Troubleshooting** section of these instructions.



Safety information

Important - Please read these instructions fully before installing or operating

- To ensure your safety, the power cord plug must be inserted into an earthed three-pole socket. Check carefully and make sure that your socket is properly and reliably earthed.
- When installing the machine, the mains plug of the power cord must be freely accessible.
- To disconnect the power cord, pull it out by plug. Do not drag the cord itself. Doing so may result in damage to the cord, leading to fire or electric shock. For safety reason, unplug the power cord from the wall outlet if the machine will not be used for an extended period of time such as holidays.
- To avoid the risk of overloading your plug socket, do not use of adapters, multiple connectors or extension cables.
- Children of less than 3 years should be kept away unless continuously supervised.
- Do not let children play with the machine.
- Packing materials may be dangerous to children. Please keep all packing materials (plastic bags, foams etc) far away from children.
- Washing machine shall not be installed in bath room or very wet rooms as well as in rooms with explosive or caustic gases.
- Make sure that the water and electrical devices are connected by a qualified technician in accordance with the manufacturer's instructions and local safety regulations.
- Before operating this machine, all packages and transport bolts must be removed. Otherwise, the washing machine may be seriously damaged while washing the clothes.
- After unpacking the washing machine, please undertake one wash cycle with no clothes first to clean the drum before using it for your clothes.
- The washing machine with single inlet valve only can be connected to the cold water supply.
- CAUTION: Do not connect to the hot water supply.
- Your washing machine is only for home use and is only designed for textiles suitable for machine washing.
- Flammable and explosive or toxic solvents are forbidden. Gasoline and alcohol etc. shall not be used as detergents and shall only select the detergents suitable for machine washing.
It is forbidden to wash carpets.
- Be careful of burning when washing machine drains hot washing water. Never refill the water by hand during washing.
- After the program is completed, please wait for two minutes to open the door.



Safety information

Important - Please read these instructions fully before installing or operating

- Please remember to disconnect water and power supply immediately after the clothes are washed.
- Do not climb up and sit on top cover of the machine.
- Do not lean against machine door.
- Please do not close the door with excessive forces. If it is found to be difficult to close the door, please check that the loading is not excessive and the load is distributed evenly.
- The household washing machine isn't intended to be built-in.
- Cautions: During handling machine
 1. Unplug the machine.
 2. Transport bolts shall be reinstalled to the machine by a qualified person.
 3. The accumulated water shall be drained out of the machine.
 4. Handle the machine carefully.
- Never hold each protruded part on the machine while lifting. Machine door can not be used as the handle during the conveyance.
- Cord entanglement hazard. The cable of the appliance can give rise to risks of entanglement, strangulation or tripping if not correctly placed. You must make sure that the electric cable is positioned safely.
- CAUTION: Do not overload the machine as it will get damaged while washing your clothes.
- Always check for the maximum dry cloth to be used in the machine before operation - see Program Selection Guide on page 22 for details.
- The maximum inlet water pressure: 1,0MPa
- The minimum inlet water pressure: 0,05MPa
- Do not attempt to repair the machine yourself.
Contact the Customer Helpline: 0345 257 7271

If you require any technical guidance or find that your product is not operating as intended, a simple solution can often be found in the **Troubleshooting** section of these instructions.

Getting to know your washing machine

2



Getting to know your washing machine

You'll be up and running in no time

Ready? Let's begin...

Please read these instructions carefully. They contain important information which will help you get the best from your washing machine and ensure safe and correct installation and operation.

If you require any further assistance, our technical experts are happy to help. For full details, refer to the product support section at the end of these instructions.

If you require any technical guidance or find that your product is not operating as intended, a simple solution can often be found in the **Troubleshooting** section of these instructions.

Getting to know your washing machine

You'll be up and running in no time

Component

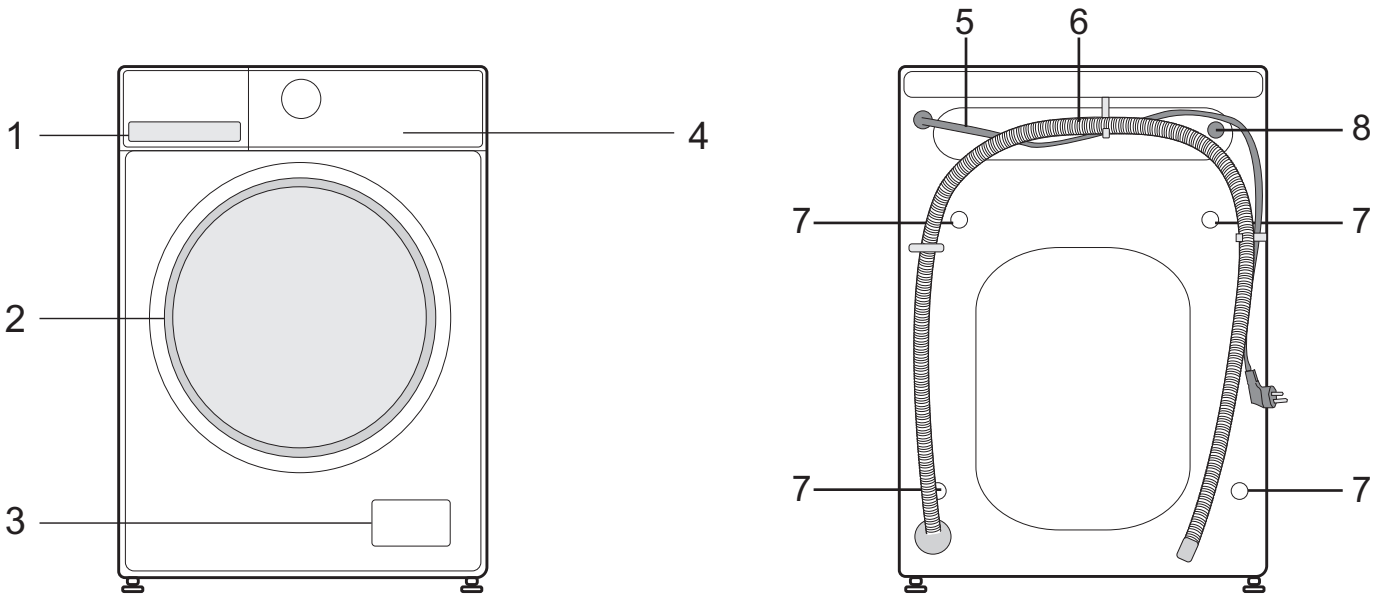

1.Detergent Drawer

2.Door

3.Filter

4.Control Panel

5.Power lead

6.Drain hose

7.Transport bolt x 4

8.Water inlet

Getting to know your washing machine

You'll be up and running in no time

Model	capacity	Spin Speed	Energy class
WMSAA1214W	12kg	1400rpm	A

Accessories

This machine includes below accessories, please install these parts by yourself before operating.

- plastic hole plug x 4
- Inlet hose
- Acoustic sponge

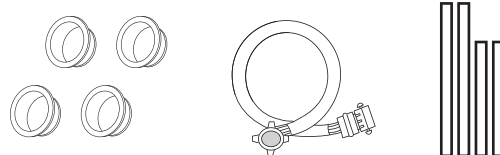

Tools

You may use these tools (not supplied) to help install above parts

- glove
- spanner/Wrench (for turning nuts in a width of 13mm and 17mm)

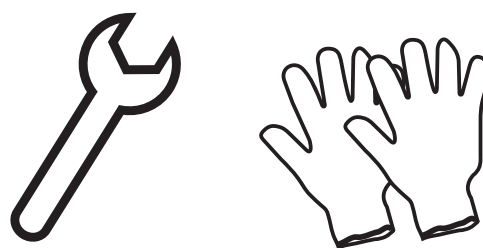

If you require any technical guidance or find that your product is not operating as intended, a simple solution can often be found in the **Troubleshooting** section of these instructions.

Installing your washing machine

3



Installing your washing machine

Bringing it all together

Installation requirements

- In addition to the instructions mentioned here, special regulations of the relevant water companies may apply. If in doubt, have the washing machine connected by a qualified technician.
- The washing machine is heavy - caution when lifting it.
- Do not lift by projecting components (e.g. washing machine door).
- Warning: Frozen hoses may tear/burst. Do not install washing machine in outdoor areas or where there is a risk of frost. Please operate washing machine above 0°C.
- Lay hoses and cables in such a way that there is no risk of tripping over them.

! An additional space (approximately 120mm) is required at the rear of the washing machine. This is to allow enough space for the water hoses.

- Dimension of the machine with door open.

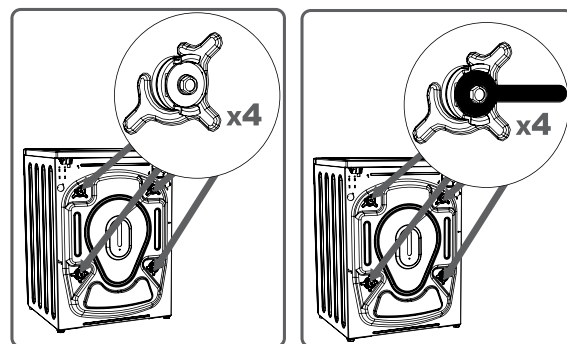
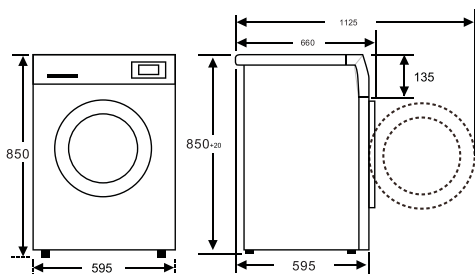

Fig 1

Fig 2

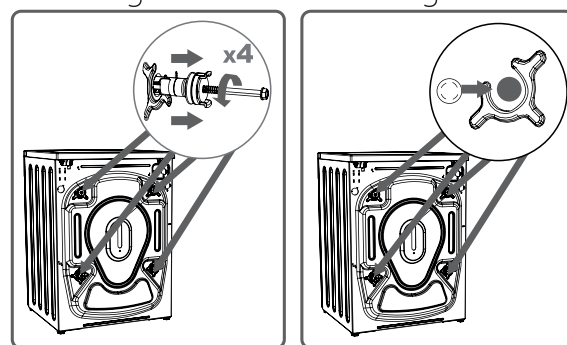

Fig 3

Fig 4

Levelling feet

1: For your machine to work efficiently with minimum vibration it should be settled on flat, nonslippery, firm ground.

2: You can adjust the balance of your machine by changing the positioning of its feet.

3: First, loosen the plastic adjustment nut. (Fig 5)

4: Adjust by rotating the feet upwards or downwards. (Fig 6)

5: After the desired position has been reached, tighten the plastic adjustment nut again by rotating it upwards.

Note: Never put cartons, wooden blocks or similar materials under the machine to balance irregularities in the level of the ground.

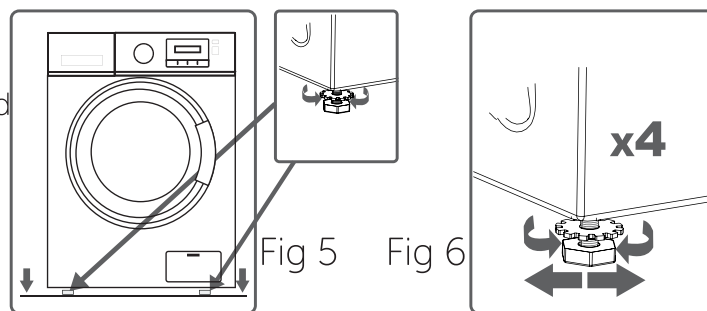

Fig 5

Fig 6

Unpacking

Unpacking your washing machine

Caution: Two people are required to unpack the washing machine, it is recommended that gloves are worn.

Carefully remove all packing materials including the foam base and dispose of correctly.

Note: When opened, water droplets may be visible in the drum etc. this is normal as each appliance is tested before delivery.

Removing the transport bolts

Important: The transport bolts are designed to support the internal components during transit and these MUST be removed before use.

1: Loosen the screws by rotating counterclockwise with a suitable wrench. (Fig 1, 2)

2: Remove the bolts by pulling them. (Fig 3)

3: When the transport bolts have been removed, insert the plastic hole pulgs found in the accessories bag into the holes. (Fig 4)

If you require any technical guidance or find that your product is not operating as intended, a simple solution can often be found in the **Troubleshooting** section of these instructions.

Installing your washing machine

Bringing it all together

Acoustic Sponges

1: Get the machine laid on the floor, using some soft material like foam or clothes between the machine and floor for a protection;

2: Stick the 2x longer sponges to the longer bottom edges of machine, and the 2x shorter sponges to the shorter bottom edges.



Please make sure to assemble the acoustic sponges, which can effectively reduce the noise caused by the machine while working, in order to provide you with a more peaceful and quiet living environment.

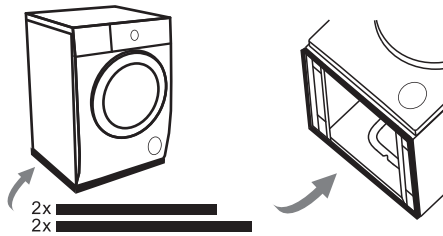

Connections

Water inlet hose connections

Important: This washing machine **MUST** only be connected to a cold water supply.

1: Connect the water inlet hose, the angled connection attaches to the water inlet on the back of the washing machine. (Fig 7)

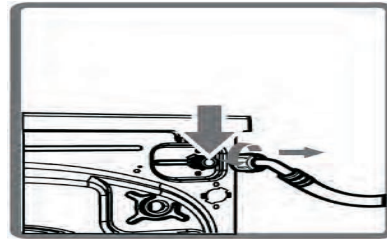

Fig 7

2: The straight connection attaches to the water supply valve. (Fig 8)

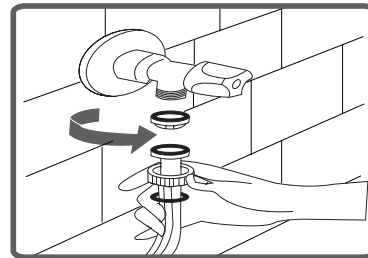

Fig 8

3: Ensure all seals are in place before connecting.

Important: Only tighten the hose connection nut by hand - do not overtighten.

Drain hose connections

Important: The height of the top of the curve in the drain hose **MUST** be between 60 - 100cm from the floor. (Fig 9)

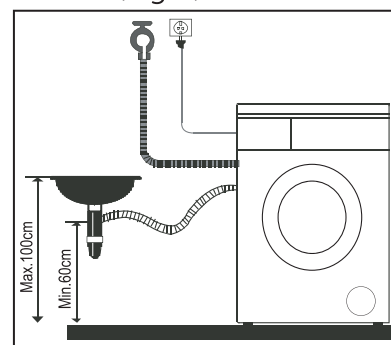

Fig 9

Drain hose can be fitted to the drainer or a wash basin.

Installing your washing machine

Bringing it all together

Electrical



Any electrical work that is required to install this appliance **MUST** be carried out by a qualified electrician.



Warning: THIS APPLIANCE MUST BE EARTHED

Before making any electrical connections, ensure that:

- Electrical safety is only guaranteed when the earth system of your house is in accordance with the related local regulations.
- Do not bend, stretch or pull the supply cable to avoid electric shock.
- Ensure the power socket is suitable for the maximum power of the machine (fuses in the power circuit must be 13 amp).
- The supply voltage should be the same as that indicated in the technical specifications and the appliance rating plate.
- The appliance should be earthed and in compliance with the applicable law.
- When installed, the power socket must be within easy reach.
- If the socket outlets in your home are not suitable for the plug supplied with this unit check with a qualified electrician for replacement.
- To avoid the risk of overloading your plug socket, adapters, multiple connectors or extension cables should not be used.
- The appliance must be connected to a 220-240 volt 50Hz AC supply by means of a three pin socket, suitably earthed and protected by a 13 amp fuse.
- Should the fuse need to be replaced, a 13 amp fuse approved to BS 1362/A must be used.
- The plug contains a removable fuse cover that must be refitted when the fuse is replaced. If the fuse cover is lost or damaged, the plug must not be used until a replacement cover has been fitted or the plug is replaced.
- A damaged plug should be cut off as close to the plug body as possible, the fuse should be removed and the plug disposed of safely.

Plug replacement(UK & Ireland only)

Should you need to replace the plug; the wires in the power cable are coloured in the following way:

Blue - Neutral ' N '

Brown - Live ' L '

Green & Yellow - Earth ' E '

As the colour of the wires in the power cable may not correspond with the coloured markings identifying the terminals in your plug, and proceed as follows (Fig 10):

The green & yellow wire must be connected to the terminal in the plug that is marked with the letter E or by the earth symbol.

The blue wire must be connected to the terminal that is marked with the letter N.

The brown wire must be connected to the terminal that is marked with the letter L.

If power supply cord is damaged, it must be replaced by the manufacturer or its service agent or a similar qualified person in order to avoid a hazard.

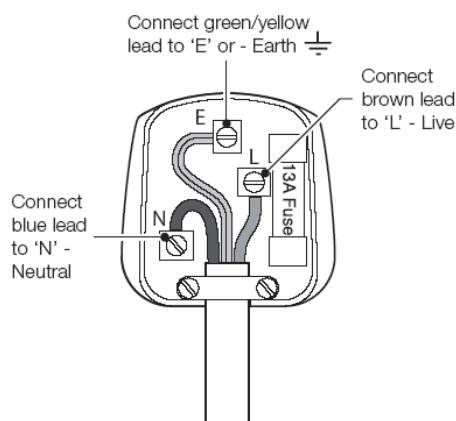

Fig 10

Functions 4



Functions

Introduction of control panel

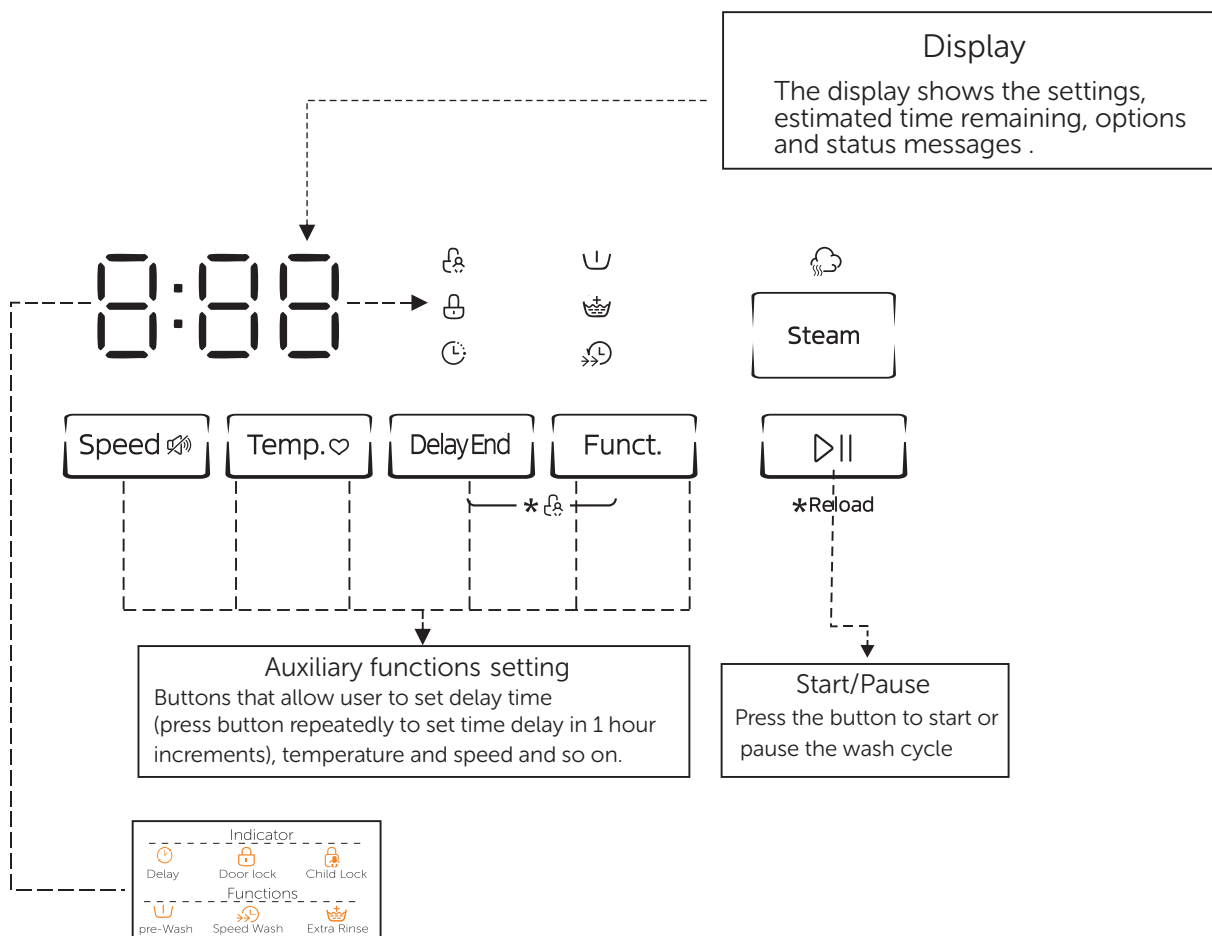
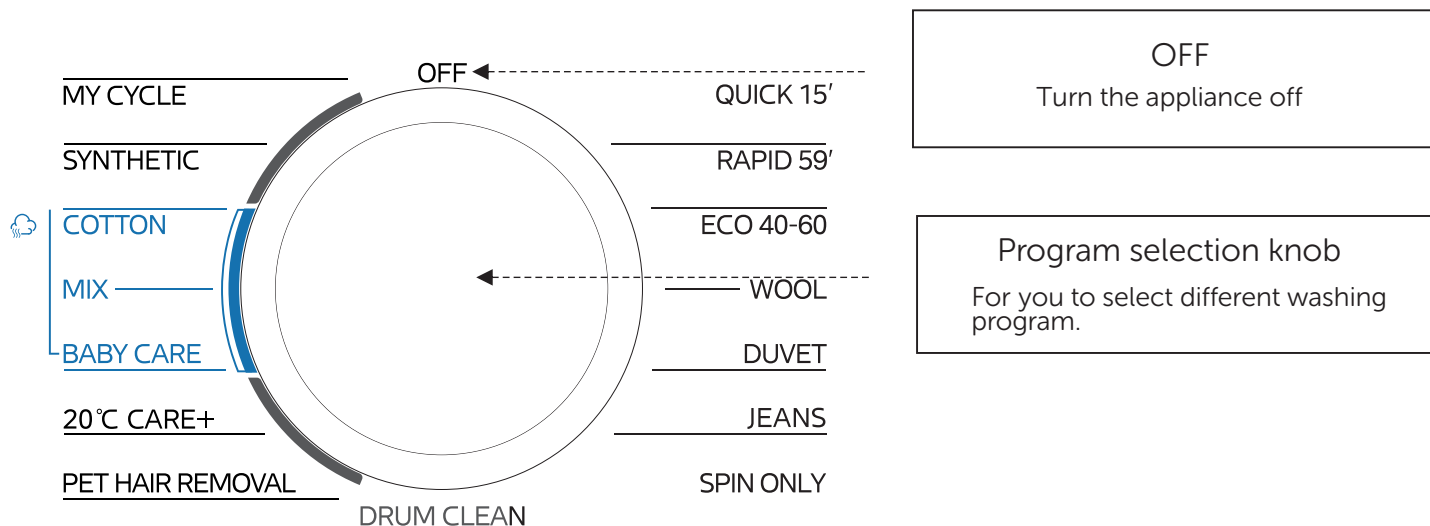

If you require any technical guidance or find that your product is not operating as intended, a simple solution can often be found in the **Troubleshooting** section of these instructions.

Functions

Simple everyday use

Introduction of control panel

Turning the machine on

Plug in your machine. Place the laundry in the machine and add detergent and softener.

Program selection

First, switch the program knob to select suitable program according to the types of textiles.

Second, select a proper temperature by following the care instructions on the clothes.

Last, select the proper spin speed.

Generally, the higher temperature will consume more energy; the higher spin speed will cause more noise.

PLEASE NOTE: to protect the delicate clothes, the lower spin speed shall be selected.

The main washing procedures depend on the types of the clothes to be washed as follows:

Main program

Depending on the type of textile, the following main programs are available: Each of these main programs comprise of a complete washing process, including washing, rinsing and, if required, spin cycles.

- **COTTON**

Hard-wearing textiles, heat-resistant textiles made of cotton or linen.

- **SYNTHETIC**

Wash synthetic articles, for example: shirts, coats, blending. While washing the knitting textiles, detergent quantity shall be reduced due to its loose string construction and easily forming bubbles.

- **BABY CARE**

Washing the baby's clothes, it can make the baby's wear cleaner. And make the rinse performance better to protect the baby skin.

- **JEANS**

Specially for jeans.

- **MIX**

Mixed load consisting of textiles made of cotton and synthetics.

- **20°C CARE+**

Able to clean lightly soiled cotton laundry, at a nominal temperature of 20 °C.

- **PET HAIR REMOVAL**

Clean the pet hair and fur from clothing deeply, restrain growth of germ.

- **SPIN ONLY**

Spins and drains the water.

- **DUVET**

This program is specially designed for washing duvet coats.

- **ECO 40-60**

Able to clean normally soiled cotton laundry declared to be washable at 40 °C or 60 °C, together in the same cycle.

- **DRUM CLEAN**

Specially set in this machine to clean the drum and tube. It applies 90 °C high temperature sterilization to make the clothes washing more green. When this programme is performed, the clothes or other washing cannot be added. When proper amount of chlorine bleaching agent is put in, the barrel cleaning effect will be better. The customer can use this programme regularly according to the need.

- **WOOL**

Hand or machine-washable wool or richwool textiles. Especially gentle wash programme to prevent shrinkage, longer programme pauses (textiles rest in wash liquor).

- **SPORT WEAR**

Washing the activewear.

- **RAPID 59'**

Washing few and not very dirty clothes quickly.

- **QUICK 15'**

Extra short programme approx, suitable for lightly soiled washing as a small amounts of laundry.

Functions

Simple everyday use

Introduction of control panel

Auxiliary function

These functions can be used based on the main program, you can press these functions after you chose the main program.

Note: you can't use these functions after the main program has started.

• Delay End 🕒

Set the Delay End function to finish your laundry at the time you select.

1. Select a programme and auxiliary function (where applicable).
2. Press [Delay End] button repeatedly to choose the delaying time from 0H to 24H, 1 hour per increment.
3. Press [Start/Pause] button to start the Delay End function.

Choose the Programme--Setting end time--Start

Notes:

- The time you have set in Delay End means the time remaining for the laundry to be finished.
- If you change to another programme after you have set Delay End, you will have to set it again.

To Cancel the Delay End function, press [Delay End] button repeatedly until the display shows 0H. If the programme has already started, switch the appliance off and afterwards on and select a new programme.

• Prewash 🪵

The Prewash function can get an extra wash before main wash, it is suitable for washing the dust rises to surface of the clothes; You need to put detergent into the Case (I) when select it. To enable this function, press the [Function] button until the Prewash indicator light on.

• Speed Wash ⚡

The function can decrease the washing time. To enable this function, press the [Function] button until the Speed Wash indicator light on.

• Extra Rinse 👑

The laundry will undergo extra rinse once after you select it.

To enable this function, press the [Function] button until the Extra Rinse indicator light on.

• Door Lock 🗝️

When the door is closed, the light will be on, and when the light is off, the door can be opened.

• Reload

If you forget to include your laundry while washing, simply press the [Start/Pause] and add any garments, from small items to large jackets, into the machine.

When the drum is still rolling and there is large amount of water with high temperature in the drum. The state is unsafe and the door cannot be opened forcefully.

Please follow the steps below for adding clothes in the midway of washing.

1. Press [Start/Pause] for 3 sec.
2. Wait until the drum stops rotation, the door lock indicator is off and the door is unlocked.
3. Close the door when the clothes are reloaded.
4. Press the [Start/Pause] again to resume the washing.

CAUTION: Risk of Scalding.

When you are washing at high temperatures, there is a risk of scalding if you come into contact with hot water or steam.

Press[Start/Pause]3sec.--Reload the clothes--Start

• Child Lock 🔒

To avoid mis operation by children.

Press [Delay End] and [Funct.]

3 sec. till buzzer beep.

When child lock is activated and program starts, child lock indicator will switch on, and the CL and remaining time on the display are alternately displayed in 0.5s. Press the other buttons will make child lock indicator flash for 3s. when program finish, CL and END alternate for 10s in 0.5s, then the child lock lights flash for 3s

- Only press and hold the two buttons simultaneously can release child lock, even power off, switch off and program end;
- The "Child Lock" will lock all buttons except Child Lock button;
- Please release child lock before selecting program and starting washing;

• Mute the buzzer 🔇

Choose the Programme

Press the [Speed] for 3sec., the buzzer is mute.

To act the buzzer function, press the button again for 3 seconds. The setting will be kept until the next reset.

After Muting the buzzer function, the sounds will not be activated any more.

Functions

Simple everyday use

Introduction of control panel

- **Temp.**

Press the button to regulate the temperature.

When needed, press the button repeatedly to select suitable water temperature.

Available options are

Cold / 20°C / 30°C / 40°C / 60°C / 90°C.

(but will subject to the availability of programme chosen.)

- **Speed**

Press the button to change the speed.

When needed, press the button repeatedly to select spinning speed. Available options are

0 / 400 / 600 / 800 / 1000 / 1200 / 1400 RPM.

(but will subject to the availability of programme chosen.)

- **Steam**

Steam is applicable for daily laundries.

The steam can deeply penetrate the fiber, which effectively eliminate bacterias and germs, preventing odors and protecting your health.

Note: This [Steam] function is only applicable to the programme of COTTON, MIX and BABY CARE.

- **My Cycle** ♥



To memory the frequently used programme, select the course and set the auxiliary function(s) as usual and then save the setting as [My Cycle] by pressing the [Temp.] button (approx. 3 sec.) until a single bleep is heard.

To recall the program, switch the program knob to select [My Cycle] and then press [Start/Pause] button to wash.

The default setting course is Cotton.

Functions

Program Selection Guide - 12kg washing machine (WMSAA1214W)

Procedure Description	Max. Load(kg) WMSAA1214W	Detergent Box			Delay	Speed wash 	Extra rinse 	Prewash 	Max.Water Temp.(°C)	Washing Time (H)	Max.Speed(RPM)
		Case I	Case II	Softener Case						WMSAA1214W	1400
Synthetic	6.0	○	●	○	○	○	○	○	40	3:18	800
Cotton	12.0	○	●	○	○	○	○	○	40	3:39	800
Mix	12.0	○	●	○	○	○	○	○	40	1:20	800
Baby Care	12.0	○	●	○	○	○	○	○	60	2:01	1000
20°C CARE+	6.0	○	●	○	○	×	○	○	20	1:08	1000
Pet Hair Removal	6.0	○	●	○	○	×	○	○	40	2:04	1200
Drum Clean	—	×	×	×	○	×	×	×	90	1:18	—
Spin Only	12.0	×	×	×	○	×	×	×	—	0:12	1000
Jeans	12.0	○	●	○	○	○	○	○	30	1:35	800
Duvet	2.5	○	●	○	○	○	○	○	40	1:48	1000
Wool	2.0	×	●	○	○	×	○	×	40	1:07	600
ECO 40-60	12.0	×	●	○	○	×	×	×	—	4:00	—
Rapid 59'	6.0	×	●	○	○	×	○	×	30	0:59	1000
Quick 15'	2.0	×	●	○	○	×	×	×	Cold	0:15	800

Concerning to EN 60456:2016 With (EU) 2019/2014, (EU) 2019/2023,
(EU) 2021/340, (EU) 2021/341

The EU energy efficiency class is: A

Energy test program: ECO 40-60. Other as the default.

Half load for 12.0Kg machine:6.0Kg.

Quarter load for 12.0Kg machine:3.0Kg.

● Means must ○ Means optional × Means not necessary

Note : Water and power consumption and programme duration may differ from the table shown, subject to changes in water pressure, water hardness and temperature, ambient temperature, type and amount of laundry, selection of auxiliary functions, and fluctuations in the supply voltage.

If you require any technical guidance or find that your product is not operating as intended, a simple solution can often be found in the **Troubleshooting** section of these instructions.

Using your washing machine

5



Using your washing machine

Getting the most from your appliance

Organising Laundry

- Read the washing label on each garment to help you sort your washing into different loads.
- Sort the laundry by colour, type of fabric and by how soiled it is. This will help you choose the correct programme and temperature for each wash.

Normal wash Gentle wash 	 Warm wash (max 40°C)	Hand wash Do not wash 	Bleach Do not bleach 	Chlorine bleach may be used Chlorine bleach not be used 	Tumble dry, Medium (max 150°C) Tumble dry, Low heat (max 110°C)
------------------------------------	-----------------------------	----------------------------------	---------------------------------	--	--

Iron Do not iron 	Cool iron(max 110°C) Warm iron,medium (max 150°C) 	Dry clean Do not dry clean 	Dry clean normal cycle with any solvent Dry clean normal cycle petroleum solvent only 	Tumble dry normal Dry flat 	Drip dry Hang to dry /Line dry
-----------------------------	---	---------------------------------------	--	---------------------------------------	--

Iron with cloth Steam Iron 	Dry after wash Line Dry in shade 	Warmly dry clean Do not tumble dry 	Line Dry 	No Wring 	No machine wash
---------------------------------------	---	---	--------------	--------------	---------------------

- Do not exceed the maximum load! See the programme selection table for the maximum load for the programme you require.

Articles / clothes	Approx. weight(g)
Cotton quilt covers (single/double)	900/1500
Bed sheets (single/double)	600/900
Work clothes	1120
Large tablecloths	700
Small tablecloths	350
Tea napkins	100
Bath towels	700
Hand towels	300
Blouses	150
Cotton shirts	300
shirts	180
cotton dresses	500
Jeans	800
Jacket	800
Handkerchiefs	100
T-shirts	150
Shorts	70
Socks	50

Preparing Laundry

- Treat stains before washing.
- Some items should be put into a cleaning net before going into the washing machine. i.e. bras with metal wires, tights and lace clothing to prevent damage.
- Check that pockets do not contain any objects which may damage your clothes and the washing machine.
- Tie up any loose strings on laundry, close zippers and reverse clothing with zips inside out.
- To prevent any large, heavy objects (e.g., buckles, large buttons, etc.) from hitting the glass door, turn your clothing inside out, or remove the heavy objects. These could damage your laundry or the washing machine.
- Remove any surplus hair, animal fur, sand, and other materials with a brush before washing.
- If clothes have raised fabric turn them inside out.
- Clothes that are not colour fast should be washed separately.
- Insert your clothes into the washing machine.
- Close the washing machine door. Ensure that you do not trap any items of clothing between the loading door and the rubber seal.

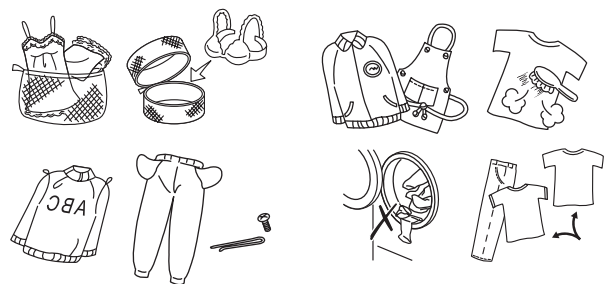

If you require any technical guidance or find that your product is not operating as intended, a simple solution can often be found in the **Troubleshooting** section of these instructions.

Using your washing machine

Getting the most from your appliance

Adding Detergent and Softener

- Add detergent into the appropriate dispenser.
- Apply softener before you start washing.
- Apply detergent and softener according to the washing amount, the soiling level, the water hardness in your area and the manufacturer's instructions of these products.



Dilute viscous fabric softener and fabric conditioner with water. Prevent blockage of the overflow. Maximum level is 40ml.

- I Pre wash
- II Main wash
- ☼ Softener
- ☉ Release button to pull out the dispenser

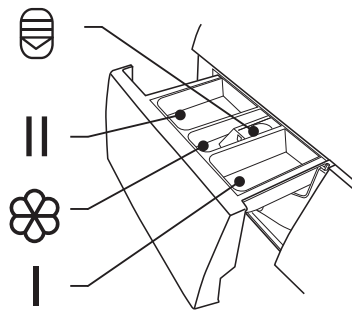

- Do not use the washing machine when the detergent drawer is removed. It may cause a water leak or it may not work normally.
- If you forget to add detergent, you can drain the washing machine by running a drain only programme. Then you can add detergent and start the programme again.
- Detergent only reaches the drum when water flushes through the detergent drawer.
- To prevent powder detergent staying in the drawer, dry the inside of the drawer with a cloth. Make sure the powder isn't lumpy when you add it into the drawer.
- If the rinse cycle isn't removing all the detergent from your wash, use less detergent.
- Softener should not exceed the MAX level in the compartment.
Wash out unused softener with a splash of water or a damp cloth after the programme has finished.

Before First Use

- Prior to the first use of the appliance, it is recommended to run a wash programme without clothes. A small amount of washing detergent should be used.

Wash Setting

Standard Washing

1. Pull the door handle and put the laundry in the drum. (Refer to Preparation to sort your laundry before it goes into the drum.) Make sure no washing gets caught in the door.
2. Close the door and press the On/Off button.
3. Turn the Programme selection dial to select your wash programme.
4. Select the temperature if desired.
5. Add detergent into the detergent drawer. The quantity of detergent will depend on the amount of laundry, the degree of soiling and the water hardness. Use the amount of detergent suggested on the packaging.
6. Press the Start/Pause button to start the washing.
7. The washing machine will sound when the programme is complete.

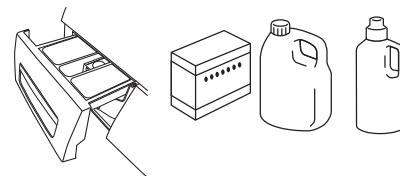

If the door is locked and you switched the washing machine off and then on - or if there's a power cut - it will stay locked for 1 minute.

Using your washing machine

Getting the most from your appliance

Recommended washing detergent	Wash cycles	Washing temp.	Type of laundry and textile
Heavy-duty detergent with bleaching agents and optical brighteners	Cotton, ECO 40-60	40/60	White laundry made from boil-proof cotton or linen
Colour detergent without bleaching agent and optical brighteners	Cotton	20/40	Coloured laundry made from cotton or linen
Color or mild detergent without optical brighteners	Cotton, Synthetic	20/40	Coloured laundry made from easy care fibres or synthetic materials
Mild washing detergent	Synthetic	20	Delicate textiles, silk, viscose
Special wool detergent	Wool	20/40	Wool

- Agglomerating or ropy detergent or additive can be diluted in some water before pouring it into the detergent dispenser, to avoid its inlet to get blocked and thus cause a water overflow.
- Please choose the suitable type of detergent to get a maximum of washing performance and a minimum of water and energy consumption
- To achieve the best cleaning result a proper detergent dosing is important.
- Use a reduced detergent amount if the drum is not filled completely.
- Always adjust the amount of detergent to the water hardness, if your tap water is soft, use less detergent.
- Dose according to how dirty your laundry is, less dirty clothes require less detergent.
- Highly concentrated (compact detergent) requires particularly accurate dosing.

Following symptoms are a sign of detergent overdosing:

- heavy foam formation
- poor washing and rinsing result

Following symptoms are a sign of detergent underdosing:

- laundry turns grey
- built-up of limescale deposits on the drum, the heating element and/or the laundry

If you require any technical guidance or find that your product is not operating as intended, a simple solution can often be found in the **Troubleshooting** section of these instructions.

Using your washing machine

Getting the most from your appliance

Removing Washing (Once programme is finished)



Door remains locked for 1 minute after wash stopped.

- Open the washing machine door and remove your washing.
- Remove any foreign objects to avoid risk of rusting.
- Leave the door and detergent drawer open so that residual water can evaporate.

1.Changing the selection after the program started?

If you need to change a setting after the wash has started, press start/pause button and turn the selector to OFF position, then re-select the program, spin speed and optional functions, and then press the Start / Pause button. (Ensure the Child Lock is off, otherwise the original program will continue.)

2.Adding/removing laundry in pause mode?

Press Start/Pause button for 3 seconds, wait until the drum stops rotating. When the door lock is unlocked, you can add/remove laundry and repress Start/Pause button after close the door.

CAUTION: Risk of Scalding.

When you are washing at high temperatures, there is a risk of scalding if you come into contact with hot water or steam.

3.Door lock

The icon lock will light up automatically once the program starts. The door lock icon will fade out as soon as the program ends and the door will be allowed to open automatically.

4.End of program

It will sound for 5 seconds after the end of program and the display will indicate "end" icon.

Using your washing machine

Getting the most from your appliance

Quick start

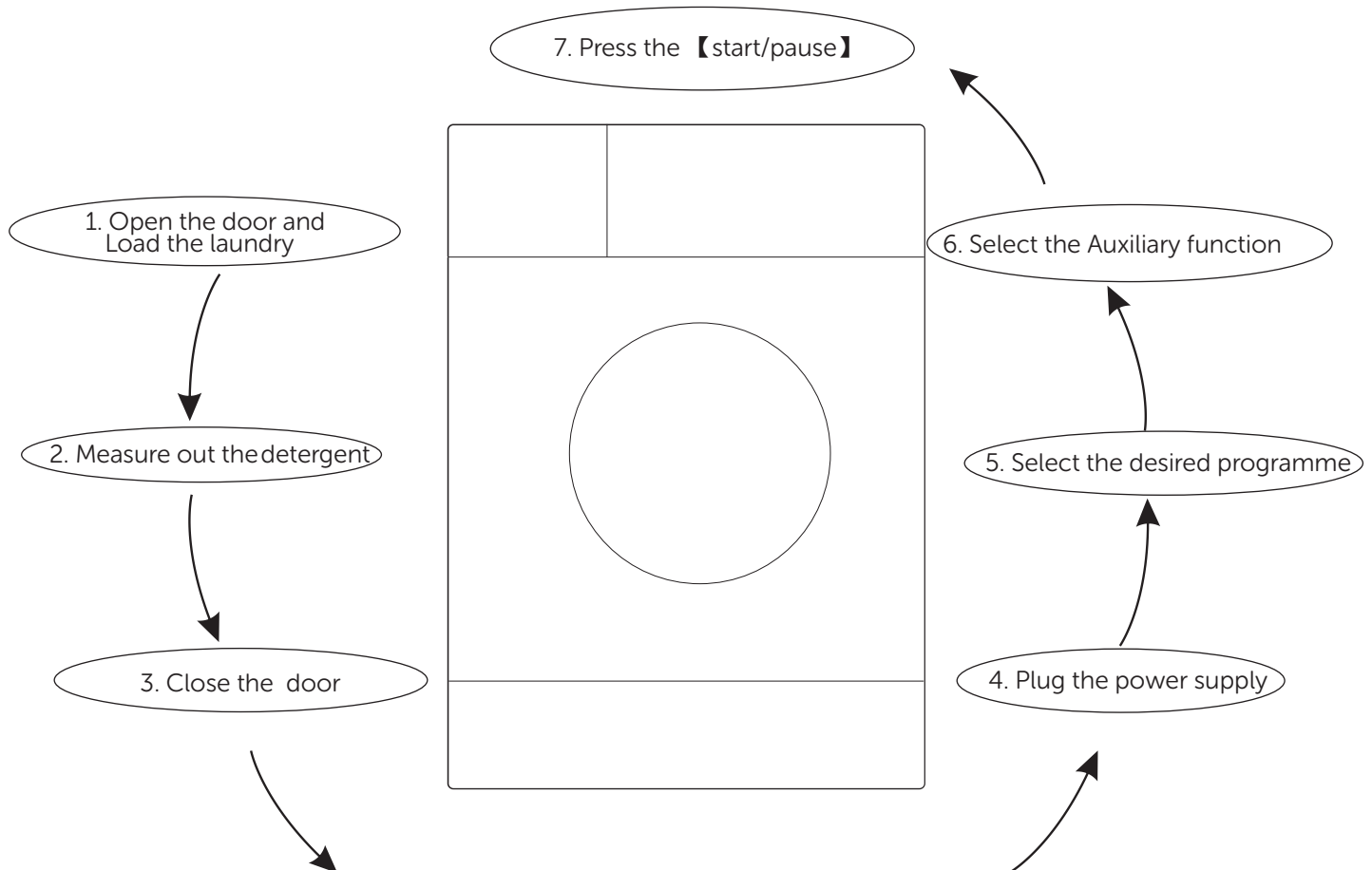

After washing :

- 1.The washing machine will sound several times for 5 seconds.
- 2.It is recommend to close the water tap and pull out the power plug.;

CAUTION: Do not overload the machine as it will get damaged while washing your clothes.

If you require any technical guidance or find that your product is not operating as intended, a simple solution can often be found in the **Troubleshooting** section of these instructions.

Care and maintenance

6



Care and maintenance

Looking after your appliance

Before your maintenance starts, disconnect the power, remove the plug from the supply and close the tap.



- Do not use solvents to clean the washing machine, as this may damage the unit and could generate toxic gases.
- Do not use the detergents containing PCMX to clean the washing machine.

Cleaning and Maintenance of Washing Machine Cabinet

- Correct maintenance on the washing machine can extend its working life. The surface can be cleaned with diluted nonabrasive neutral detergents when necessary. If there is any water overflow, use a wet cloth to wipe it off immediately.
- No sharp items are allowed to strike the cabinet.

Notes: Do not use formic acid and its diluted solvents or equivalent.

Clean Internal Drum

- Rust left inside the drum by metal articles shall be removed immediately with chlorine-free detergents.
- Never use steel wool.

Defrost a Frozen Washing Machine

When the temperature drops below zero and your washing machine gets frozen, you may:

1. Disconnect the power supply for the washing machine.
2. Wash the tap with warm water to loosen inlet pipe.
3. Take down inlet pipe and immerse it in warm water.
4. Pour warm water into washing drum and wait for 10 minutes.
5. Reconnect inlet pipe to the tap and check whether inlet and outlet are working normally.

Notes: when the washing machine is reused, make sure the ambient temperature is above 0°C

Anti-freeze

If your washing machine is located in the room where it can get frozen easily, please drain the remaining water inside drain pipe and inlet pipe thoroughly.

Remove the remaining water in inlet pipe:

1. Close the tap.
2. Screw off the inlet pipe from tap and put its end into a container.
3. Start up any procedure except single Wash or Drain procedure. Water will be drained out of inlet pipe if any for about 40 seconds.
4. Reconnect the inlet pipe to tap. Remove the remaining water in drain pump (Fig 11).

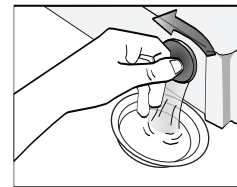

Fig 11

Clean detergent drawer and grooves

1. Press down the arrow location on softener cover inside the drawer.
2. Lift the clip up and take out softener cover and wash all grooves with water.
3. Restore the softener cover and push the drawer into position.

Clean the detergent dispenser every 3 months to ensure the normal operation of the appliance

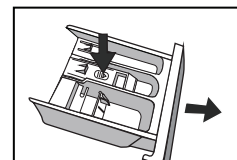

Fig 12

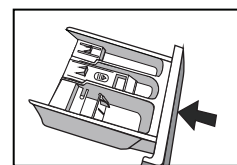

Fig 13

Clean inlet filter

Inlet filter must be cleaned if there is insufficient water when the tap is opened.

Clean the tap filter:

1. Close the tap.
2. Select any procedure except "Wash" or "Drain" procedure.
3. Press the button "Start/Pause" and keep the procedure running for about 40 seconds.
4. Remove the inlet pipe from the tap.
5. Use water to wash the filter.
6. Reconnect the inlet pipe. Washing the filter in washing machine:
1. Screw off the inlet pipe from the backside of the machine.
2. Pull out the filter with long nose pliers and reinstall it back after being washed.
3. Reconnect the inlet pipe.

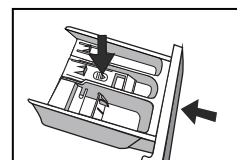

Fig 14

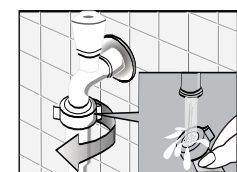
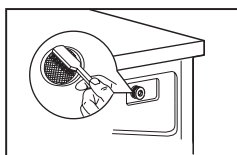
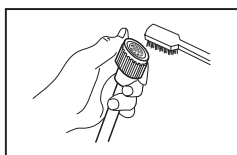

Fig 15

Care and maintenance

Looking after your appliance

4. Open the tap and make sure there is no water leakage.
5. Close the tap.
6. Clean the Inlet filter every 3 months to ensure the normal operation of the appliance.



Notes: Generally, the tap filter is washed first and then the filter in washing machine will be washed.

If only the filter in washing machine is washed, then the steps 1~3 in cleaning the tap filter shall be repeated (Fig16, 17).

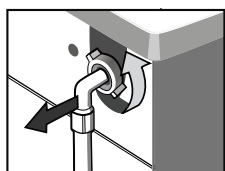

Fig 16

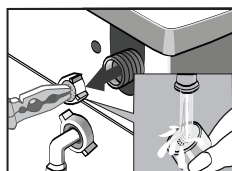

Fig 17



Pull out the power plug to avoid electrical shock before washing.

After using the washing machine, remove all the clothes and close the door tightly.

Remove foreign matters

Drain Pump Filter:

Drain pump filter can filter the yarns and small foreign matters from the washings.

Clean the filter periodically to ensure the normal operation of washing machine.

According to the soil level within the cycles and the frequency of the cycles, you have to inspect and clean the filter regularly.

The pump should be inspected if the machine does not empty and/or spin; The machine makes an unusual noise during draining due to objects such as safety pins, coins etc. blocking the pump.

Clean the pump filter :

1. After the power is disconnected, use hand to open the filter cover (Fig 18).

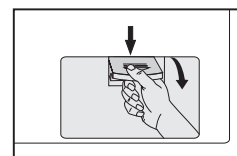

Fig 18

2. Turn the filter down as shown with the figure and take out sundries matters (Fig 19).

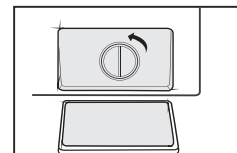

Fig 19

3. Reinstall each part after sundries matters are removed (Fig 20).

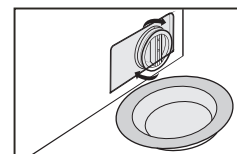

Fig 20

4. Clean the filter periodically every 3 months to ensure the normal operation of the appliance.

Warning!

When the appliance is in use and depending on the programme selected there can be hot water in the pump. Never remove the filter during a wash cycle, always wait until the appliance has finished the cycle, and is empty. When replacing the filter, ensure it is securely retightened.

Care and maintenance

Looking after your appliance

Technical specification

Model identifier: WMSAA1214W					
General product parameters:					
Parameter	Value		Parameter	Value	
Rated capacity ^(a) (kg)	12.0		Dimensions in cm ^(b)	Height	85
				Width	60
				Depth	60
EEl _w ^(a)	52.0		Energy efficiency class ^(a)	A ^(c)	
Washing efficiency index ^(a)	1.031		Rinsing effectiveness (g/kg) ^(a)	5.0	
Energy consumption in kWh per cycle, based on the eco 40-60 programme. Actual energy consumption will depend on how the appliance is used.	0.544		Water consumption in litre per cycle, based on the eco 40-60 programme. Actual water consumption will depend on how the appliance is used and on the hardness of the water.	57	
Maximum temperature inside the treated textile ^(a) (°C)	Rated capacity	40	Remaining moisture content ^(a) (%)	Rated capacity	53.9
	Half	32		Half	53.9
	Quarter	23		Quarter	53.9
Spin speed ^(a) (rpm)	Rated capacity	1351	Spin-drying efficiency class ^(a)	B ^(c)	
	Half	1351			
	Quarter	1351			
Programme duration ^(a) (h:min)	Rated capacity	4:00	Type	free-standing	
	Half	3:00			
	Quarter	3:00			
Airborne acoustical noise emissions in the spinning phase ^(a) (dB(A) re 1 pW)	78		Airborne acoustical noise emission class ^(a) (spinning phase)	C ^(c)	
Off-mode (W)	0.50		Standby mode (W)	1.00	
Delay start (W) (if applicable)	4.00		Networked standby (W) (if applicable)	NA	
Minimum duration of guarantee offered by the supplier ^(b) : 12					
This product has been designed to release silver ions during the washing cycle			NO		
Additional information:					
Weblink to the supplier's website, where the information in point 9 of Annex II to Commission Regulation (EU) 2019/2023 (1) (b) is found: https://www.argos.co.uk/product/9341179					
^(a) for the eco 40-60 programme.					
^(b) changes to these items shall not be considered relevant for the purposes of paragraph 4 of Article 4 of Regulation (EU) 2017/1369.					
^(c) if the product database automatically generates the definitive content of this cell the supplier shall not enter these data.					

If you require any technical guidance or find that your product is not operating as intended, a simple solution can often be found in the **Troubleshooting** section of these instructions,

Care and maintenance

Looking after your appliance

WMSAA1214W

Cycle	Nominal capacity in kg	Cycle duration in hours and minutes	Energy consumption in kWh/operating cycle	Water consumption in liter/operating cycle	Highest temperature °C ¹⁾	residual moisture in % /spin speed ²⁾
Cotton	12.0	3:44	1.919	99	60	70%/800
Mix	12.0	1:20	0.988	99	40	70%/800
20°C CARE+	6.0	1:08	0.218	58	20	65%/1000
Baby Care	12.0	2:01	1.739	99	60	65%/1000
Quick 15'	2.0	0:15	0.030	31	Cold	70%/800
ECO 40-60 ³⁾	12.0	4:00	1.168	83	40	53.9%/1351
	6.0	3:00	0.638	58	32	53.9%/1351
	3.0	3:00	0.253	46	23	53.9%/1351

- The above data is for reference only, and the data may change due to different actual use conditions.
- The values given for programmes other than the ECO 40-60 programme are indicative only.
- 20°C CARE+ is able to clean lightly soiled cotton laundry, at a nominal temperature of 20 °C, which complies with the regulation (EU) 2019/2023.
- Concerning to EN 60456:2016/A11:2020 With(EU) 2019/2014, (EU) 2019/2023, (EU) 2021/340, (EU) 2021/341,

The EU energy efficiency class is: A

Energy test program: ECO 40-60. Other as the default.

Half load for 12.0kg machine:6.0kg.

Quarter load for 12.0kg machine:3.0kg.

Care and maintenance

Special note for Eco design

- 1) The highest temperature reached by the laundry in the wash cycle for at least 5 minutes.
- 2) Residual moisture after the wash cycle in water content percent and the spin speed at which this was achieved.
- 3) The ECO 40-60 programme is able to clean normally soiled cotton laundry declared to be washable at 40°C or 60°C, together in the same cycle. This programme is used to assess the compliance with the regulation (EU) 2019/2023.

The most efficient programmes in terms of energy consumption are generally those that perform at lower temperatures and longer duration.

Loading the household washing machine up to the capacity indicated for the respective programmes will contribute to energy and water savings.

Noise and remaining moisture content are influenced by the spinning speed: the higher the spinning speed in the spinning phase, the higher the noise and the lower the remaining moisture content.

Caution! If there is any break in the power supply while the machine is operating, a special memory stores the selected programme. The machine will continue the programme when the power supply is re-established.

The model information can be retrieved using the QR-Code reported in the energy label. The label also includes the model identifier that can be used to consult the portal of the registry at <https://eprel.ec.europa.eu>.

1. The higher the spinning speed in the spinning phase, the higher the noise and the lower the remaining moisture content.
2. The guarantee will be rendered invalid if the product has been damaged by inexpert repair.

Product support

7



Product support

Help is always at hand

Troubleshooting

1. Washing Machine does not operate?

Check if the door is closed tightly, power plug is inserted well and then press start/pause button.

2. Washing Machine does not receive water?

Check if the water tap is opened and clean the filters of water inlet hose.

3. Washing Machine is not draining water?

Check the drain hose and clean pump filter.

4. Washing Machine is vibrating?

Check if the feet are adjusted well and make sure transportation screws are removed.

5. The washing result is poor?

Select suitable program and use more detergent.

6. No water is seen in the drum during washing?

No failure. The water is in the lower part of the drum.

7. There are residues of detergent on the clothes?

Some detergents contain ingredients which are not soluble in water and which may form white stains on your clothes. Please adjust your machine, carry out an additional rinse, or eliminate the stains after drying, with a brush.

8. There are grey stains on the clothes?

These stains may be caused by oil, cream or ointment. In the next washing operation, use the maximum detergent amount declared by the detergent producer.

Error Codes

Description	Possible cause	Solution
E30	Door is not closed properly	Close the door properly and restart.
E10	Water injecting problem during wash cycle.	Check if the water pressure is high enough. Straighten the water pipe. Clean the inlet valve filter.
E21	Overtime water draining	Check the drain hose for blockage.
E12	Water overflow	Restart the appliance.
EXX	Others	Restart the appliance. If problem persists, please contact the customer service.

If you require any technical guidance or find that your product is not operating as intended, a simple solution can often be found in the **Troubleshooting** section of these instructions.

Product support

Help is always at hand

Help and assistance

If you require any technical guidance or find that your <washing machine> is not operating as intended, a simple solution can often be found in the **Troubleshooting** section of these instructions or online at

www.argos-support.co.uk

If you still require further assistance, call one of our experts on **0345 257 7271*** To help give us give you a fast and efficient service please have the following information ready:

Model Ref.	<input type="text"/>	You can find these on the rating plate - a small information panel (usually a sticker or metal plate) on the rear of your appliance
Serial number	<input type="text"/>	
Date of purchase	<input type="text"/>	This will be shown on your receipt

Local call rates applies*

Lines open 8am-7pm Monday to Saturday and 10am-4pm Sunday.

*Calls to Argos enquiry lines may attract a charge and set up fee from residential lines depending on your call plan/tarif. Mobile and other providers costs may vary, see www.bt.com/pricing for details.

For Security and training purposes, telephone calls to and from customer service centres maybe recorded and monitored. Calls from Republic of Ireland will attract international call charges.

or online at www.bush-support.com If you still require further assistance, call one of our experts on **0345 257 7271**.

Product support

Help is always at hand

Spare Parts Supply

To order spare parts, please contact our customer helpline: 0345 257 7271.

The original spare parts for some specific components are available for a period of 10 years, based on the type of component, from the placing on the market of the last unit of the model.



This appliance complies with the following EEC directives:
2014/35/EU low voltage directive
2014/30/EU EMC directive

Notes on disposal:



This marking indicates that this product should not be disposed with other household wastes throughout the UK. To prevent possible harm to the environment or human health from uncontrolled waste

disposal, recycle it responsibly to promote the sustainable reuse of material resources. To return your used device, please use the collection systems or contact the retailer where the product was purchased. They may return and may take this product for environmental safe recycling.

If you require any technical guidance or find that your product is not operating as intended, a simple solution can often be found in the **Troubleshooting** section of these instructions.

Product support

Help is always at hand

BUSH

Call us now and activate your 12 month guarantee

Thank you for choosing Bush. Your new product is guaranteed against faults and breakdowns for 12 months. Don't forget to register it with us today so we can provide you with our best possible after-sales service and useful updates.

www.bushregistration.co.uk

FREEPHONE*

0800 597 8548

Lines are open 8am - 8pm, 365 days a year. *Calls may be recorded and monitored.

Your Bush Guarantee

This product is guaranteed for twelve months from the date of original purchase. Any defect that arises due to faulty materials or workmanship will be repaired free of charge (or if applicable the product will be replaced or the purchase price refunded) where possible during this period by the dealer from who your purchased the unit.

The guarantee is subject to the following provisions:

- The guarantee does not cover accidental damage, misuse, cabinet parts, knobs or consumable items.
- The product must be correctly installed and operated in accordance with the instructions contained in the manual.
- It must be used solely for domestic purposes. The guarantee will be rendered invalid if the product is re-sold or has been damaged by inexpert repair.
- Specifications are subject to change without notice.
- Bush disclaim any liability for loss or damage arising from the breakdown of the product.
- This guarantee is in addition to and does not diminish your statutory or legal rights.

Important Data Protection Information

To find out how we and Domestic & General Insurance Plc use your data please refer to the guarantee registration material or visit www.bushregistration.co.uk.

Guarantor: Argos Limited - London - EC1N 2HT

or online at www.bush-support.com If you still require further assistance, call one of our experts on 0345 257 7271.

BUSH

Produced in China for
Argos Limited, London, EC1N 2HT, UK.
Argos (N.I.) Ltd., Forestside Shopping Centre,
Upper Galwally, Belfast, BT8 6FX, UK.

Contact:

www.bush-support.com

Helpline: 0345 257 7271