

11 16 7L

ARG

487



Assembly Instructions

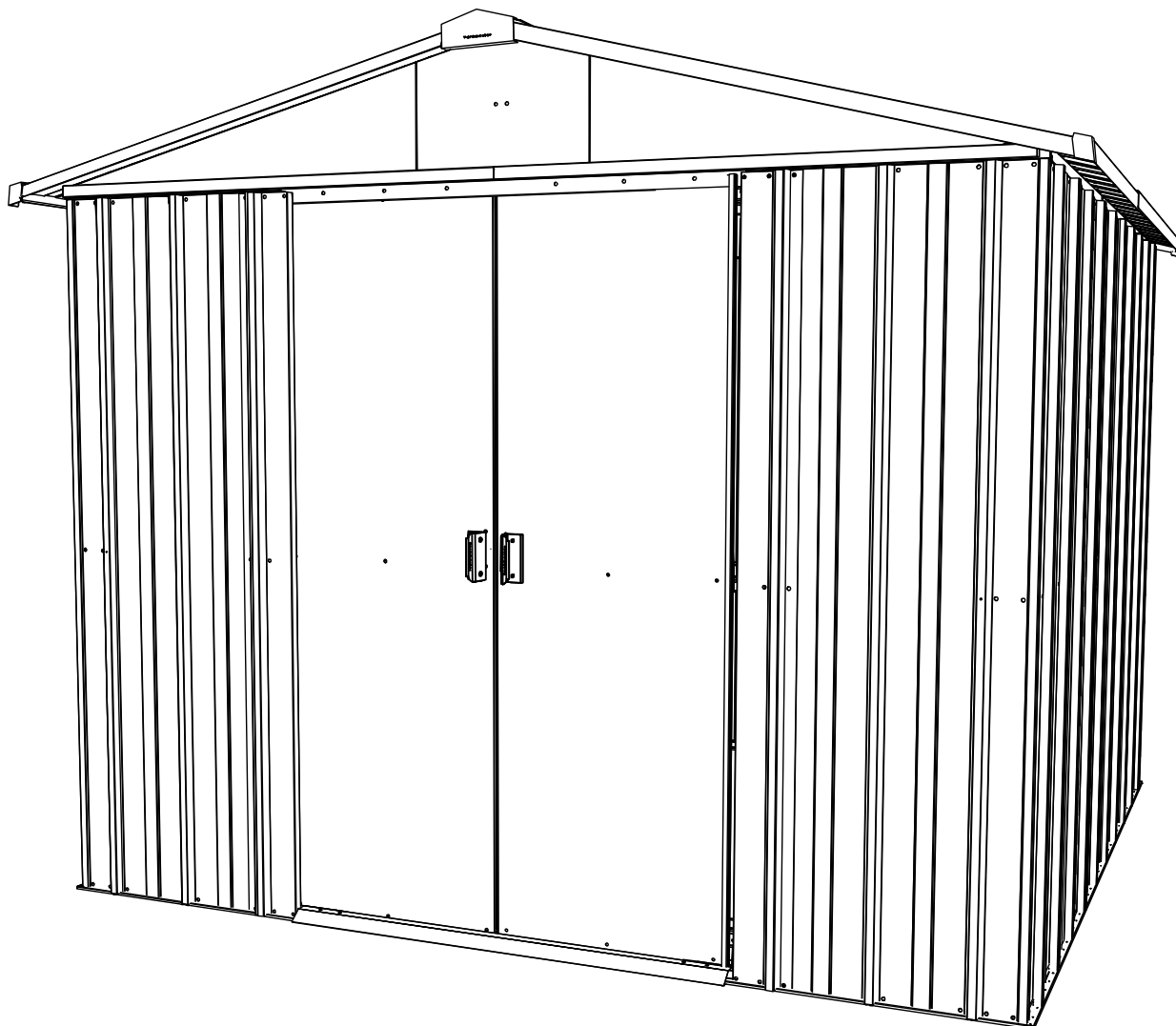

668/5553

86 GEYZ

If you have any queries, need help with this product or would like to order a replacement part, please contact our customer helpline on the free phone number below

Tel: 0800 107 2260

Email: info@yardmaster.co.uk

YOU WILL NEED / VOUS AUREZ BESOIN DE / SIE BRAUCHEN / U HEEFT NODIG / AVRETE BISOGNO DI / VOCÊ IRÁ PRECISAR DE / NECESITARÁ

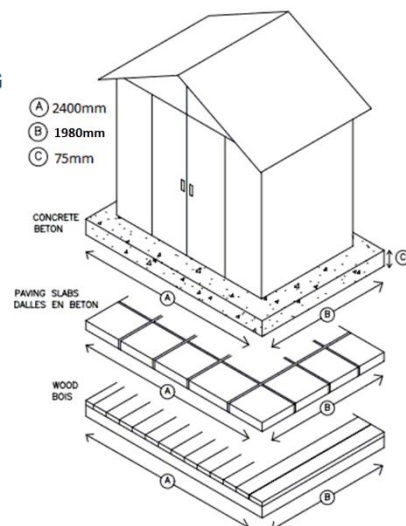
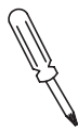
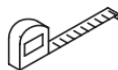

GB-IE

- ✓ BEFORE STARTING, READ THROUGH THE ASSEMBLY INSTRUCTIONS CAREFULLY.
- ✓ CHECK THOROUGHLY ALL THE PARTS YOU HAVE RECEIVED AGAINST THE PARTS DIAGRAMS PAGES 3-5.
- ✓ ENSURE THAT NO PARTS ARE DAMAGED.
- ✓ ALWAYS ASSEMBLE THE ROOF FIRST, ESPECIALLY IF YOU DO NOT INTEND TO COMPLETE CONSTRUCTION ON THE SAME DAY.
- ✓ DO NOT ERECT YOUR BUILDING ON A WINDY DAY. ANY BUILDING LEFT PARTIALLY CONSTRUCTED MAY BE DAMAGED.
- ✓ ALL ASSEMBLY OPERATIONS MUST TAKE PLACE ON A LEVEL SURFACE.
- ✓ WASHERS TO BE USED ON ALL SCREWS
- ✓ THE SHED SHOULD BE SECURELY ANCHORED TO A FIRM LEVEL BASE EG CONCRETE, PAVING SLABS OR WOOD. CONCRETE SHOULD BE LAID A MINIMUM OF 75MM THICK AT APPROX. 25MM ABOVE GROUND LEVEL. A SHEET OF HEAVY DUTY POLYTHENE PLACED UNDER THE BASE AREA WILL HELP PREVENT DAMPNES RISING FROM THE GROUND INTO THE SHED.

SAFETY

- ✓ IT IS RECOMMENDED THAT YOU WEAR GLOVES WHEN ASSEMBLING THIS PRODUCT
- ✓ TWO PERSON OPERATION
- ✓ KEEP CHILDREN AWAY DURING ASSEMBLY

D

- ✓ Vor Beginn, machen Sie sich mit den Montageanweisungen vertraut
- ✓ Überzeugen Sie sich an Hand der Schaubilder (Seiten 3-5), ob alles vollzähig ist und die Teile nicht beschädigt sind.
- ✓ Das Dach zuerst montieren, besonders wenn Sie den Aufbau nicht am gleichen Tag beenden wollen.
- ✓ Stellen Sie das Haus nicht an einem stürmischen Tag auf. Jedes Haus würde unter solchen Wetterbedingungen beschädigt werden.
- ✓ Das Gerätehaus muß auf einer vollständig ebenen Fläche errichtet werden.
- ✓ Scheiben für Verwendung mit allen Schrauben.
- ✓ Das Gerätehaus muß auf einer festen ebenen Fläche verankert werden, z.B. auf Beton, Betonplatten, Holz. Die Betonplattform soll mindestens 75mm stark und mindestens 25mm über dem Boden sein. Ein Laken aus Hochleistungskunststoff unter dem Fundament wird dazu helfen, Feuchtigkeit vorzubeugen, die von der Erde in den Schuppen hineindringt.

Sicherheitsmaßnahmen

- ✓ Es wird empfohlen, Handschuhe bei der Montage zu tragen
- ✓ Montage mit zwei Personen
- ✓ Während der Montage keine Kinder unbeaufsichtigt neben dem Gerätehaus spielen lassen

I

- ✓ PRIMA DI INIZIARE, LEGGETE ATTENTAMENTE LE ISTRUZIONI DI ASSEMBLAGGIO
- ✓ CONTROLLATE ATTENTAMENTE TUTTE LE PARTI CHE AVETE RICEVUTO, CONFRONTANDOLE CON LE PARTI NEI DIAGRAMMI ALLE PAGINE 3-5.
- ✓ ASSICURATEVI CHE LE PARTI NON SIANO DANNEGGIATE.
- ✓ MONTATE SEMPRE PRIMA IL TETTO, SOPRATTUTTO SE NON INTENDETE COMPLETARE LA COSTRUZIONE IL GIORNO STESSO.
- ✓ NON MONTATE LA VOSTRA COSTRUZIONE IN UNA GIORNATA DI VENTO, PERCHÉ COSTRUZIONI PARZIALMENTE COSTRUITE POTREBBERO SUBIRE DANNI.
- ✓ TUTTE LE OPERAZIONI DI ASSEMBLAGGIO DEVONO ESSERE EFFETTUATE SU UNA SUPERFICIE PIANA.
- ✓ LE RONDELLE VANNO UTILIZZATE PER TUTTE LE VITI.
- ✓ IL CAPANNO DOVREBBE ESSERE FISSATO SALDAMENTE SU UNA SOLIDA BASE, AD ESEMPIO CEMENTO, MATTONELLE O LEGNO. IL CEMENTO DOVREBBE ESSERE STESO CON UNO SPESSORE DI MINIMO 75 MM, CIRCA 25MM AL DI SOPRA DEL LIVELLO DEL TERRENO. UN FOGLIO DI POLIETILENE RESISTENTE POSTO SOTTO ALLA BASE AIUTERÀ A PREVENIRE L'UMIDITÀ PROVENIENTE DAL TERRENO.

Sicurezza

- ✓ È RACCOMANDATO L'USO DEI GUANTI PER L'ASSEMBLAGGIO
- ✓ DI QUESTO PRODOTTO.
- ✓ L'OPERAZIONE DEVE ESSERE EFFETTUATA DA DUE PERSONE. TENETE LONTANI I BAMBINI DURANTE L'ASSEMBLAGGIO.

FR

- ✓ AVANT DE COMMENCER LIRE ATTENTIVEMENT LA NOTICE DE MONTAGE
- ✓ VÉRIFIER PRÉCISEMENT SI VOUS AVEZ BIEN REÇU TOUTES LES PIÈCES ÉNONCÉES SUR LE SCHÉMA PAGE 3-5.
- ✓ ASSUREZ VOUS QU'AUCUNE PIÈCE N'A ÉTÉ ENDOMMAGÉE.
- ✓ ASSEMBLER EN PRIORITÉ LE TOIT SURTOUT SI VOUS PENSEZ NE PAS FINIR LE MONTAGE DANS LA JOURNÉE.
- ✓ NE JAMAIS MONTER VOTRE ABRÍ PAR GRAND VENT. NE PAS LAISSER UN ABRÍ PARTIELLEMENT MONTÉ. LES PIÈCES POUVANT ÊTRE ENDOMMAGÉES.
- ✓ TOUTES LES OPÉRATIONS DE MONTAGE DOIVENT ÊTRE RÉALISÉES SUR UNE SURFACE PLANE.
- ✓ UTILISEZ LES RONDELLES AVEC TOUTES LES VIS
- ✓ L'ABRI DOIT ÊTRE FIXÉ AU SOL SUR UNE SURFACE PLANE, PAR EXEMPLE BETON, DALLES EN BETON, BOIS ETC. LE BETON DOIT ÊTRE COULÉ SUR UNE ÉPAISSEUR DE 75MM, SOIT 25MM AU DESSUS DU NIVEAU DU SOL. L'UTILISATION D'UNE TOILE DE POLYTHÈNE ÉPAISSE ET RÉSISTANTE, PLACÉE SOUS LA BASE AIDERA À EMPÊCHER L'HUMIDITÉ DE MONTER DU SOL DANS L'ABRI.

SÉCURITÉ

- ✓ Il est recommandé de porter des gants de travail pendant le montage
- ✓ CETTE OPÉRATION NÉCESSITE DEUX PERSONNES.
- ✓ NE LAISSEZ PAS LES ENFANTS MANIPULER LE PRODUIT.

NL

- ✓ LEES VOORDAT U BEGINT EERST ZORGVULDIG DE MONTAGE-INSTRUCTIES.
- ✓ CONTROLEER ALLE ONDERDELEN DIE U HEEFT ONTVANGEN ZORGVULDIG AAN DE HAND VAN DE ONDERDELENSCHEMA'S OP PAGINA'S 3-5.
- ✓ CONTROLEER DAT ONDERDELEN NIET BESCHADIGD ZIJN.
- ✓ MONTEER ALTIJD EERST HET DAK, VOORAL ALS U NIET VAN PLAN BENT DE CONSTRUCTIE OP DEZELFDE DAG AF TE RONDEN.
- ✓ ZET HET GEBOUW NIET OP EEN WINDERE DAG OP. GEDEELTELIJK GEMONTEERDE BOUWWERKEN KUNNEN BESCHADIGD RAKEN.
- ✓ ALLE MONTAGEWERKZAAMHEDEN MOMENTEN OP EEN VLAkke ONDERGROND WORDEN UITGEVOERD.
- ✓ ER MOETEN RINGEN WORDEN GEBRUIKT BIJ ALLE SCHROEVEN.
- ✓ DE SCHUUR MOET GOED WORDEN VASTGEZET OP EEN STEVIGE, VLAkke ONDERGROND, BIJVOORBEELD BETON, TEGELS OF HOUT. BEGON MOET EEN MINIMALE DIKTE VAN 75 MM HEBBEN MET ONGEVEER 25 MM BOVEN GRONDNIVEAU. EEN DIK VEL POLYETHYLEEN ONDER DE ONDERZIJDE HELPT HET OPTREKKEN VAN VOCHT IN DE SCHUUR TE VOORKOMEN.

Veiligheid

- ✓ HET WORDT AANBEVOLEN HANDSCHOENEN TE DRAGEN BIJ HET MONTEREN VAN DIT PRODUCT.
- ✓ UITVOEREN MET TWEE PERSONEN.
- ✓ KINDEREN UIT DE BUURT HOUDEN TIJDENS MONTAGE.

E

- ✓ ANTES DE COMENZAR, LEA LAS INSTRUCCIONES DEL MONTAJE ATENTAMENTE.
- ✓ REVISE CUIDADOSAMENTE TODAS LAS PIEZAS QUE HAYA RECIBIDO CON LAS PÁGINAS 3-5 DEL DIAGRAMA DE LAS PIEZAS.
- ✓ ASEGÚRESE DE QUE NINGUNA PIEZA ESTÁ DAÑADA.
- ✓ PRIMERO, ENSAMBLE SIEMPRE EL TECHO, ESPECIALMENTE SI NO PRETENDE TERMINAR EL MONTAJE EL MISMO DÍA.
- ✓ NO MONTE LA CONSTRUCCIÓN DURANTE DÍAS CON VIENTO. CUALQUIER MONTAJE PARCIALMENTE CONSTRUIDO PUEDE RESULTAR DAÑADO.
- ✓ TODAS LAS OPERACIONES DE MONTAJE DEBEN REALIZARSE SOBRE UNA SUPERFICIE PLANA.
- ✓ SE DEBEN EMPLEAR ARANDELAS EN TODOS LOS TORNILLOS.
- ✓ LA CASETA DEBE ESTAR BIEN SUJETA A UNA BASE NIVELADA FIRME, POR EJEMPLO, DE HORMIGÓN, LOSAS O MADERA. EL HORMIGÓN DEBE TENER UN MÍNIMO DE 75MM DE GROSOR EN APROX. 25MM SOBRE EL NIVEL DEL SUELO. UNA HOJA DE POLIETILENO PESADO BAJO LA SUPERFICIE BASE AYUDARÁ A PREVENIR LA HUMEDAD PROVENIENTE DE LA TIERRA A LA CASETA.

Seguridad

- ✓ SE RECOMIENDA USAR GUANTES DURANTE EL ENSAMBLAJE DE ESTE PRODUCTO.
- ✓ SE TRATA DE UN MONTAJE A REALIZAR POR DOS PERSONAS.
- ✓ MANTENGA A LOS NIÑOS ALEJADOS DURANTE EL MONTAJE.

P

- ✓ ANTES DE COMEÇAR, LEIA ATENTAMENTE AS INSTRUÇÕES DE MONTAGEM.
- ✓ VERIFIQUE CUIDADOSAMENTE TODAS AS PEÇAS RECEBIDAS E COMPARE-AS COM AS DOS ESQUEMAS DAS PÁGINAS 3-5.
- ✓ CERTIFIQUE-SE DE QUE NÃO HÁ PEÇAS DANIFICADAS.
- ✓ MONTE SEMPRE O TELHADO EM PRIMEIRO LUGAR, ESPECIALMENTE SE NÃO PRETENDE TERMINAR A CONSTRUÇÃO NO MESMO DIA.
- ✓ NÃO EFETUE A MONTAGEM NUM DIA VENTOSO. QUALQUER CONSTRUÇÃO DEIXADA PARCIALMENTE MONTADA PODE SOFRER DANOS.
- ✓ TODAS AS OPERAÇÕES DE MONTAGEM DEVEM SER REALIZADAS SOBRE UMA SUPERFÍCIE PLANA.
- ✓ TODOS OS PARAFUSOS DEVEM LEVAR ANILHAS.
- ✓ O ABRIGO DEVE FICAR BEM FIXO A UMA BASE NIVELADA E FIRME, POR EXEMPLO, DE BETÃO, LAJES OU MADEIRA. A BASE DE BETÃO DEVE TER UMA ESPESSURA MÍNIMA 75 MILÍMETROS E FICAR APROXIMADAMENTE A 25 MILÍMETROS ACIMA DO NÍVEL DO CHÃO. UMA FOLHA DE POLIETILENO INDUSTRIAL ESTICADA SOB A ÁREA DA BASE IRÁ AJUDAR A EVITAR QUE A HUMIDADE DO SOLO PASSE PARA O ABRIGO.

Segurança

- ✓ RECOMENDA-SE QUE USE LUVAS DURANTE A MONTAGEM DESTE PRODUTO.
- ✓ OPERAÇÃO A SER FEITA POR DUAS PESSOAS.
- ✓ MANTENHA AS CRIANÇAS AFASTADAS DURANTE A MONTAGEM.

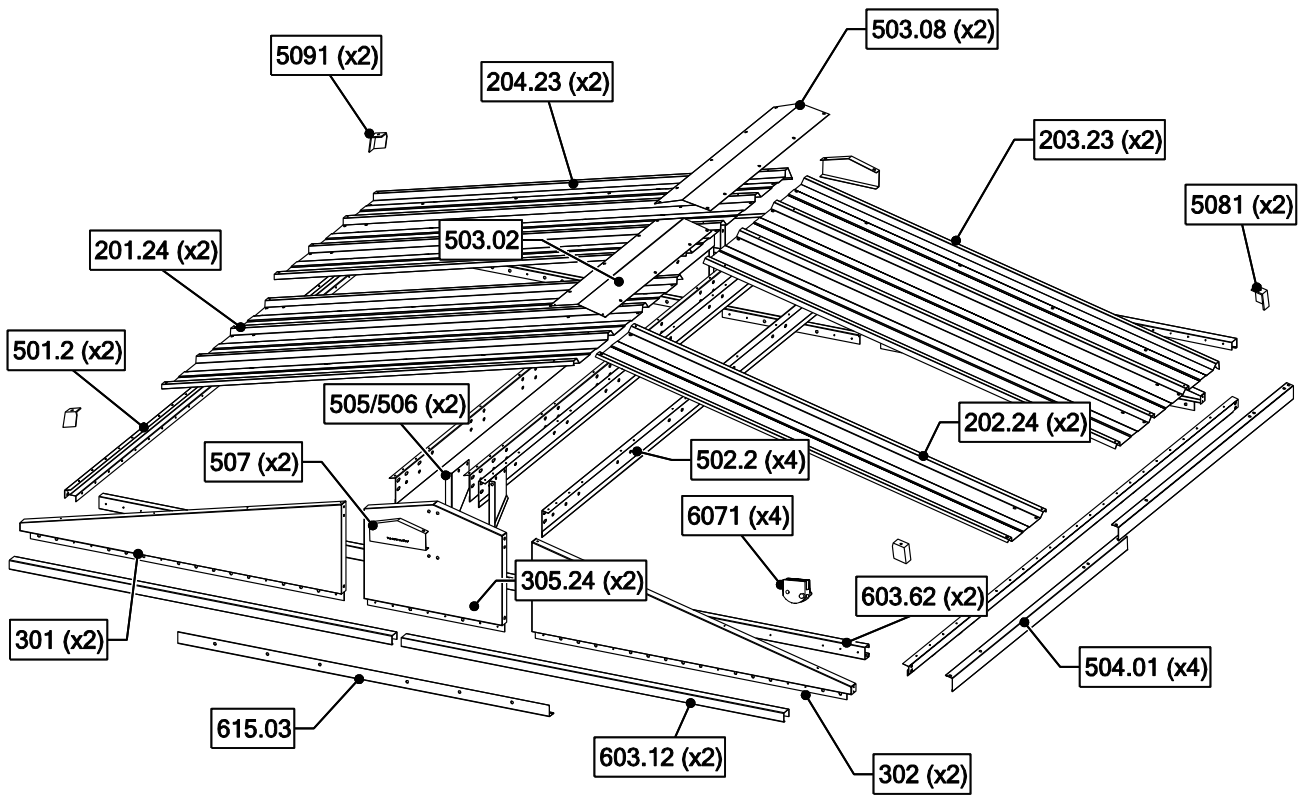

201.24	x2	1215mm		501.2	x2	1834mm		507	x2	160mm	
202.24	x2	1215mm		502.2	x4	1834mm		5081	x2	45mm	
203.23	x2	1215mm		503.02	x1	615mm		5091	x2	45mm	
204.23	x2	1215mm		503.08	x2	690mm		603.12	x4	1095mm	
301	x2	920mm		504.01	x4	1015mm		603.62	x2	1090mm	
302	x2	920mm		505	x2	145mm		615.03	x1	1064mm	
305.24	x2	395mm		506	x2	145mm		6071	x4	30mm	

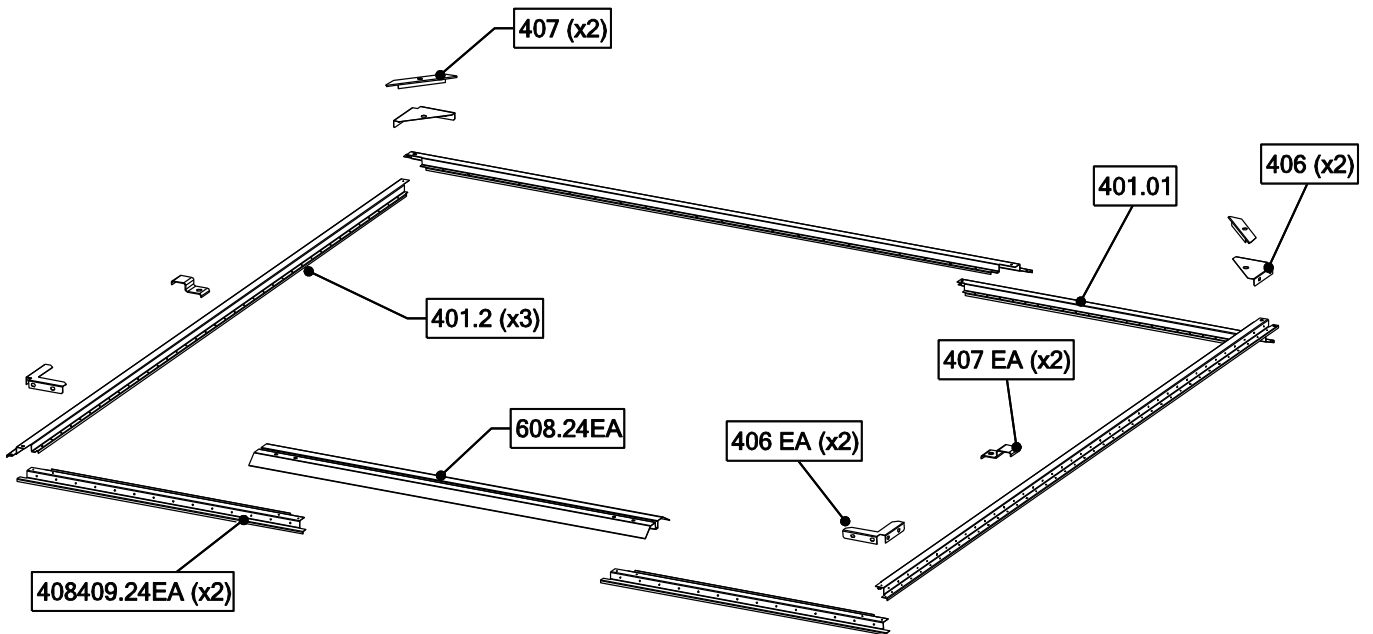

401.01	x1	633mm		407	x2	150mm	
401.2	x3	1833mm		407EA	x2	69mm	
406	x2	86mm		408409.24EA	x2	733mm	
406EA	x2	86mm		608.24EA	x1	1016mm	

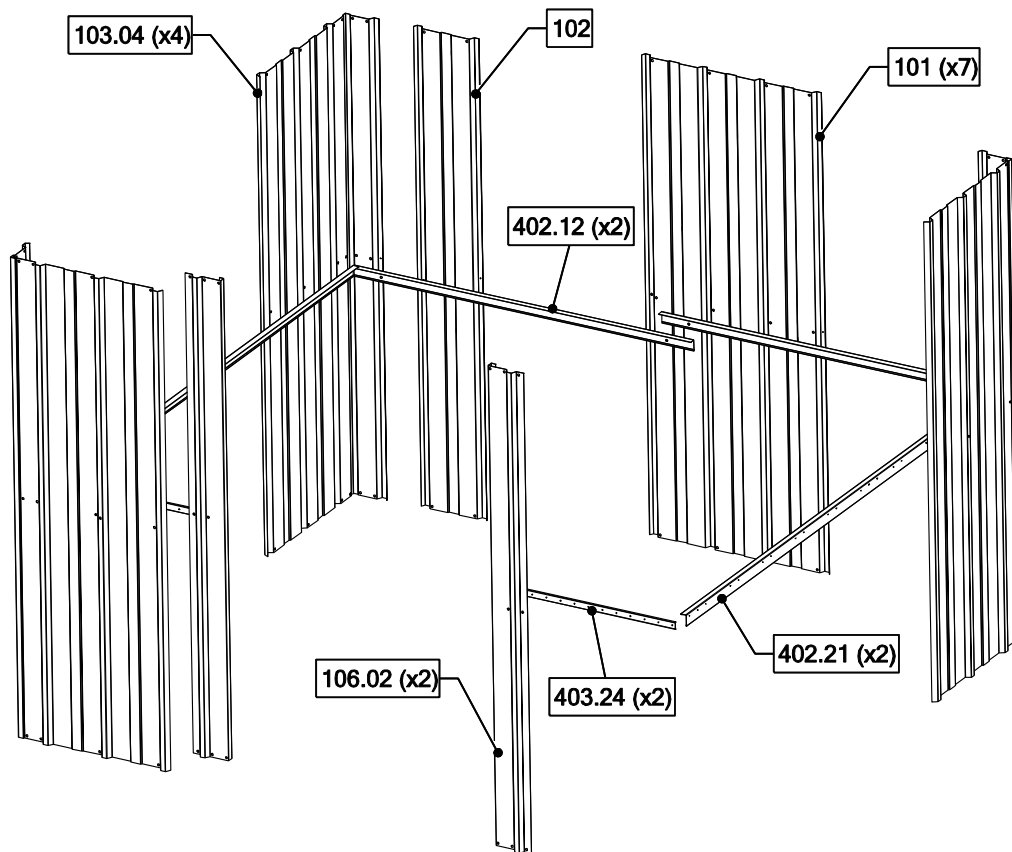

101	x7	1600mm		402.12	x2	1190mm	
102	x1	1600mm		402.21	x2	1788mm	
103.04	x4	1600mm		403.24EA	x2	565mm	
106.02	x2	1600mm					

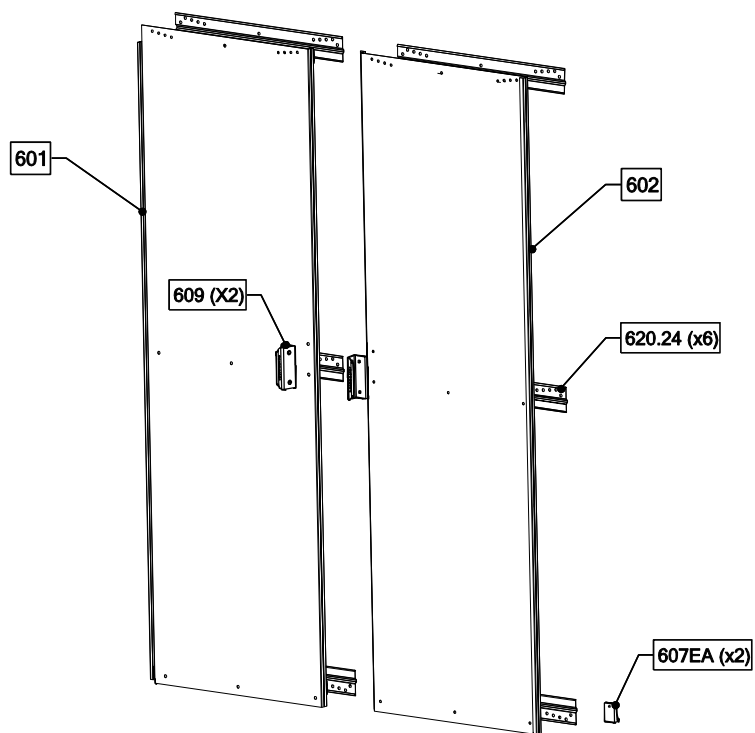

601	x1	1593mm		609	x2	100mm	
602	x1	1593mm		620.24	x6	525mm	
607EA	x2	26mm					

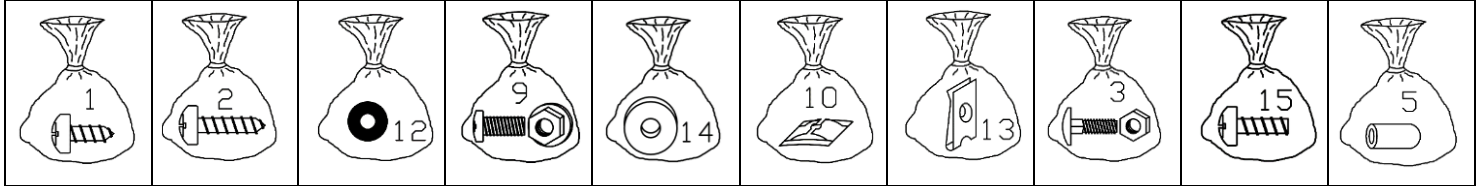
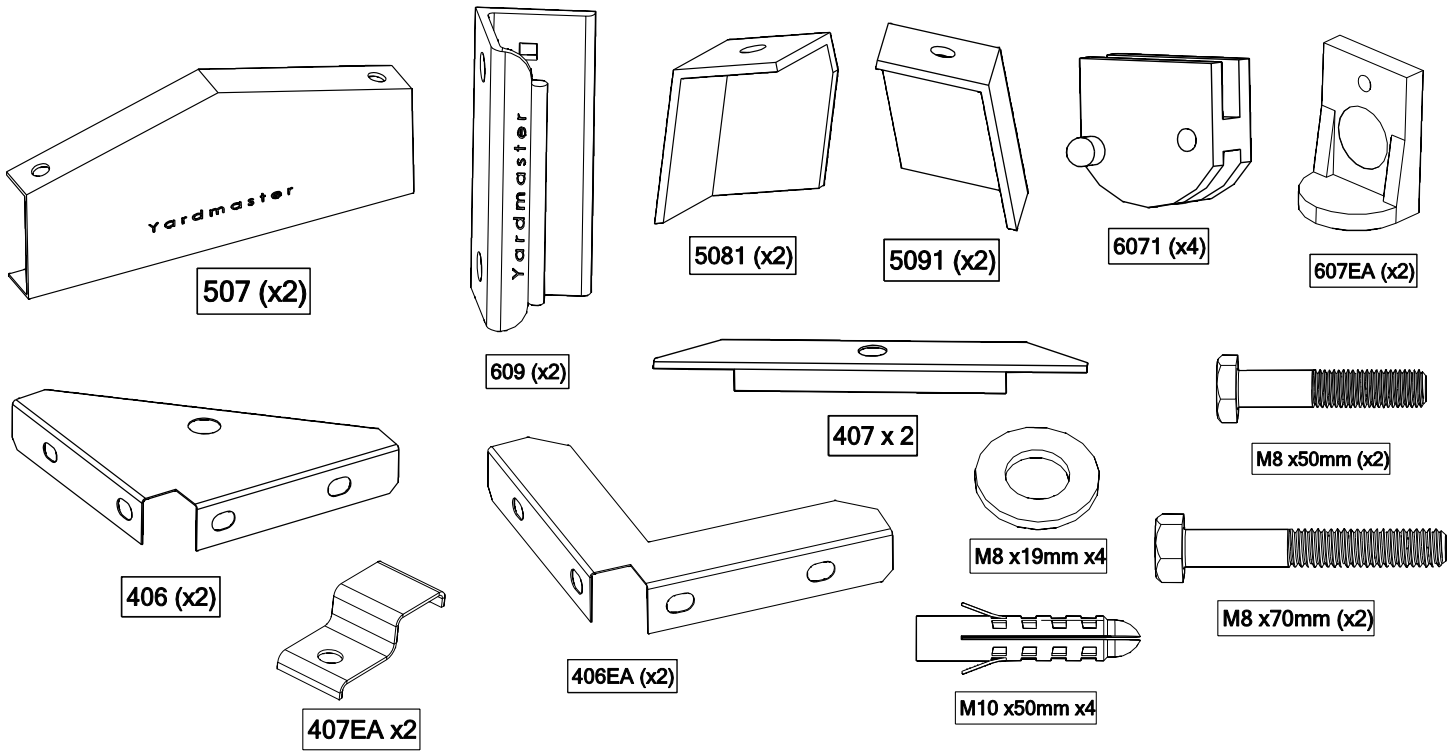

- Step
- Etape
- Schritt
- Stap
- Paso
- Passo

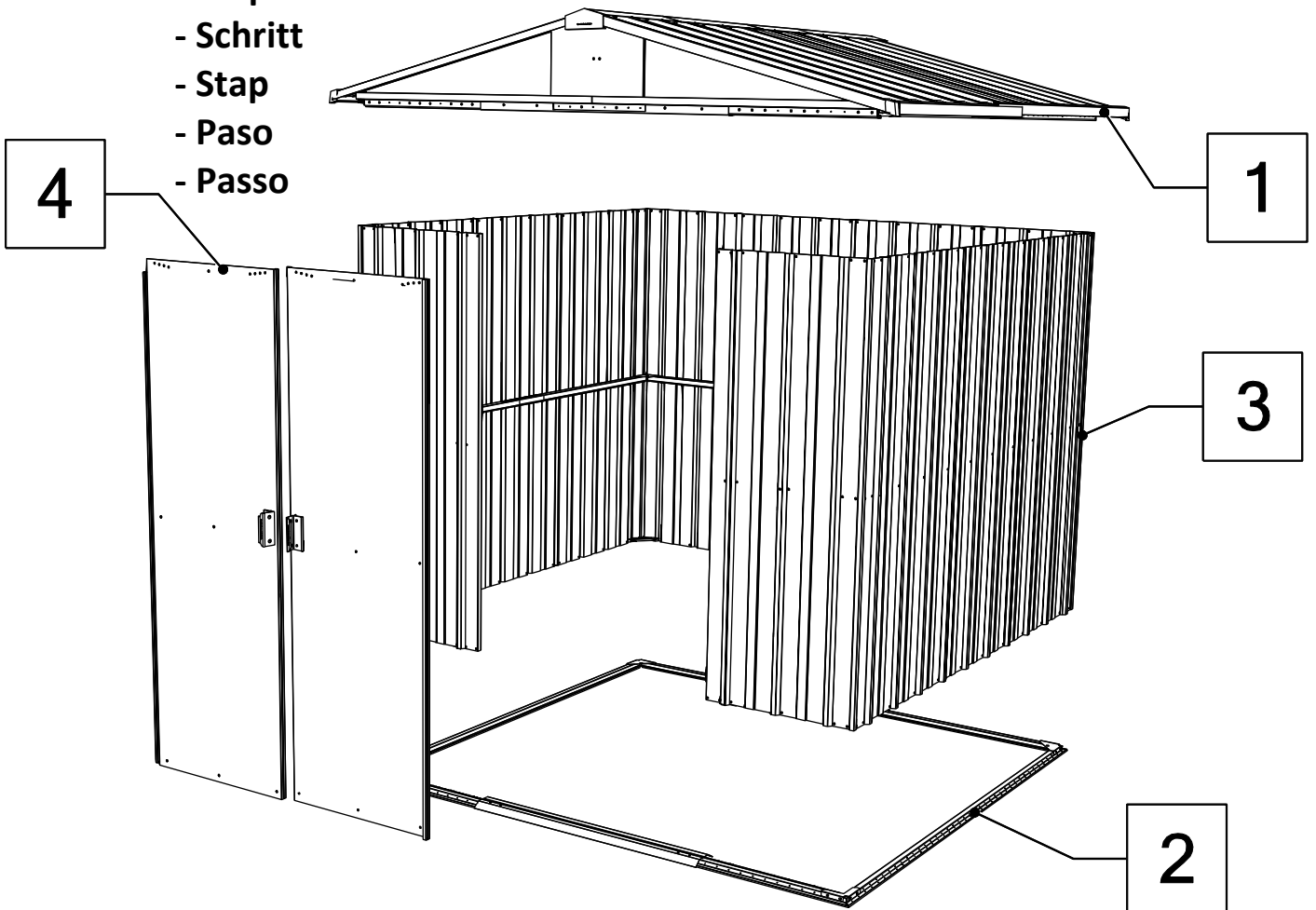

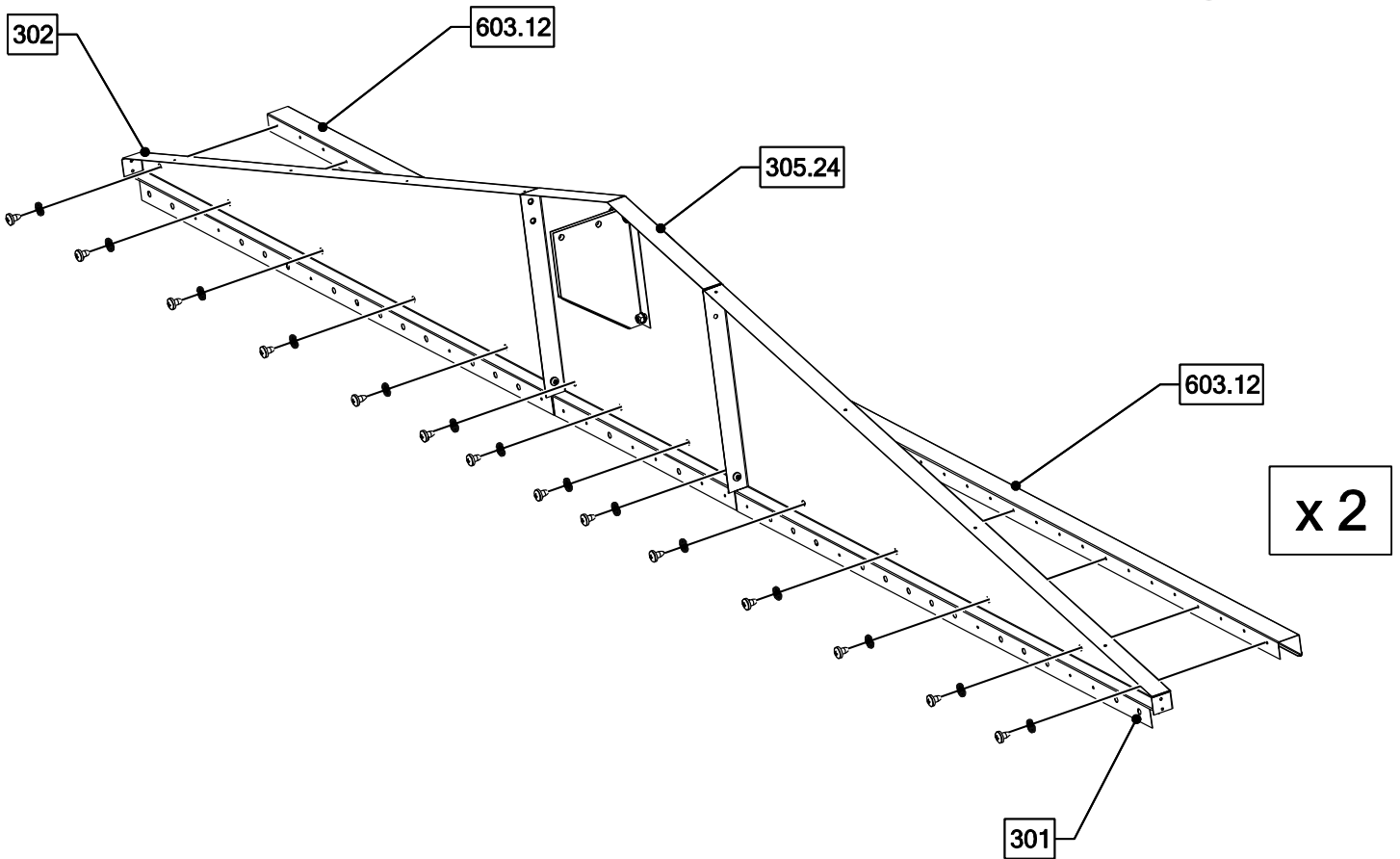
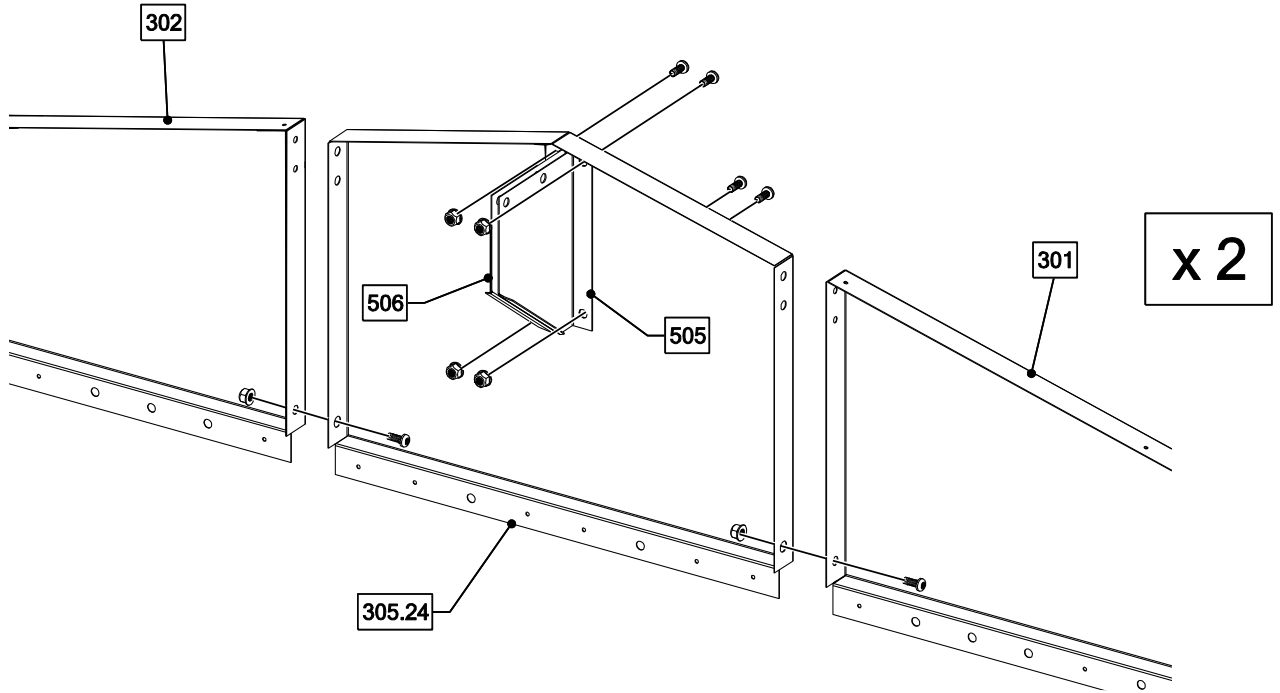
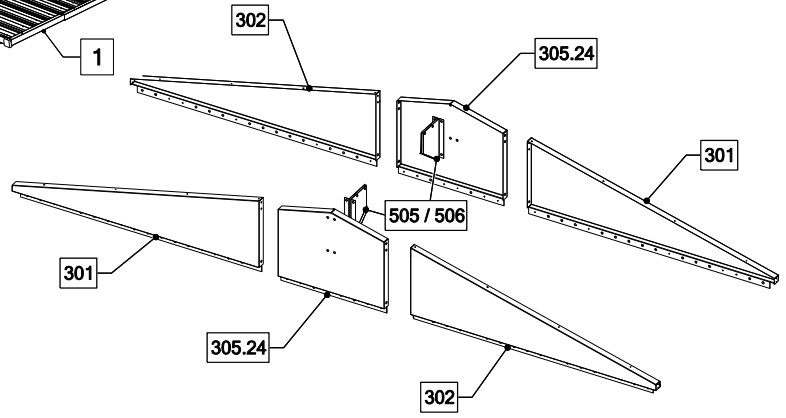
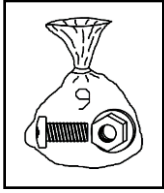
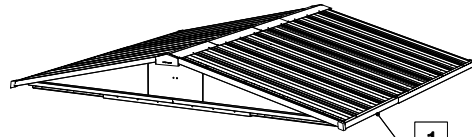

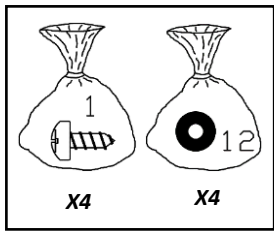

x 1

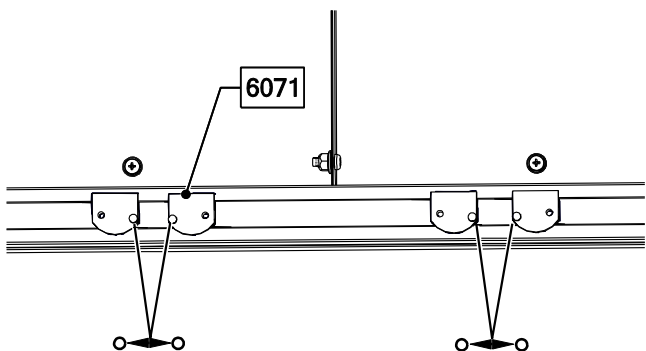
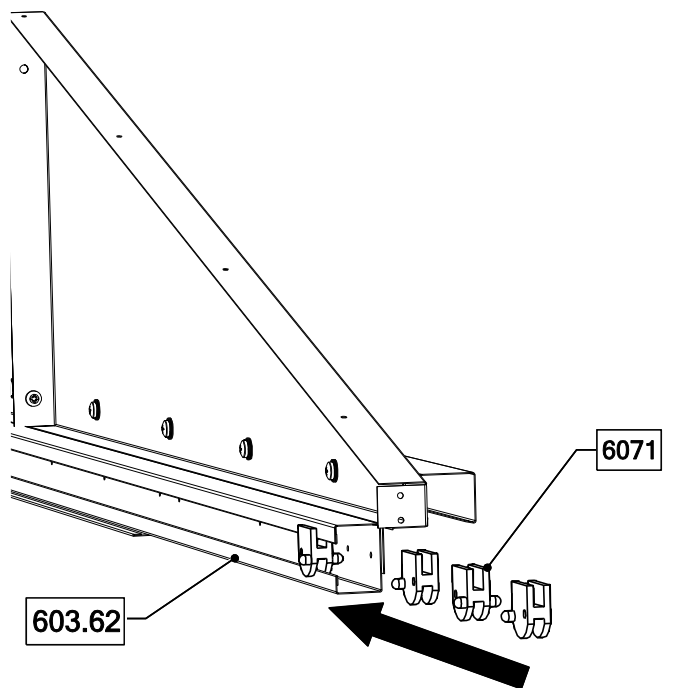
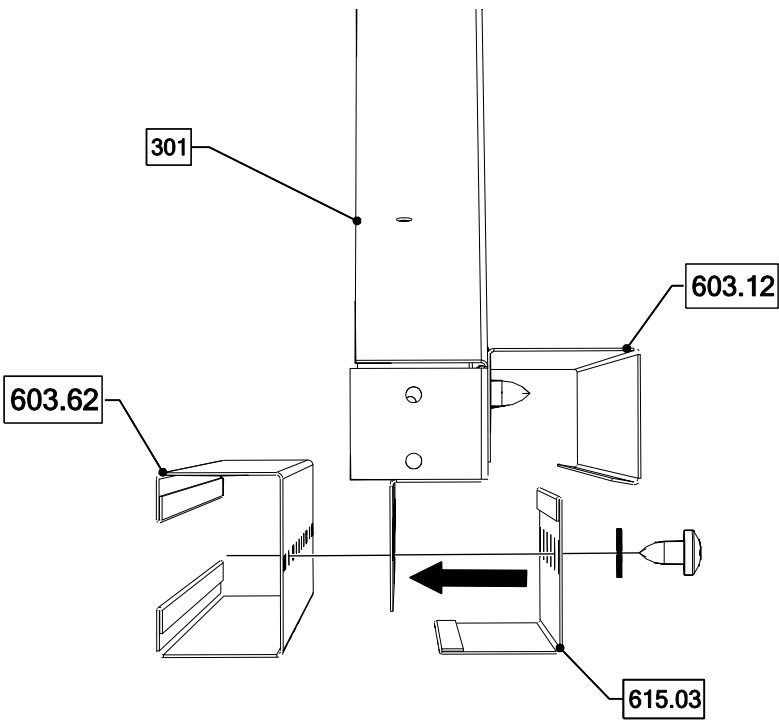
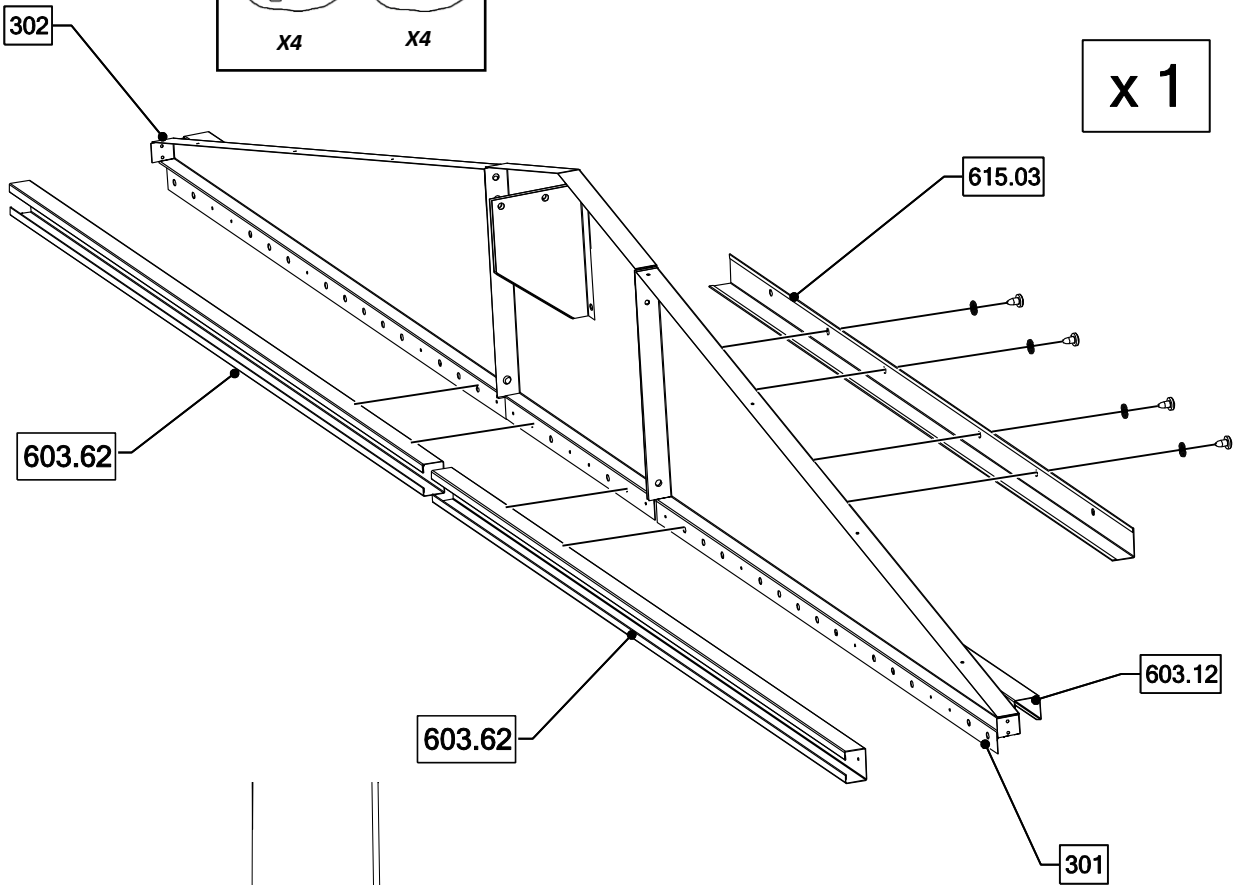

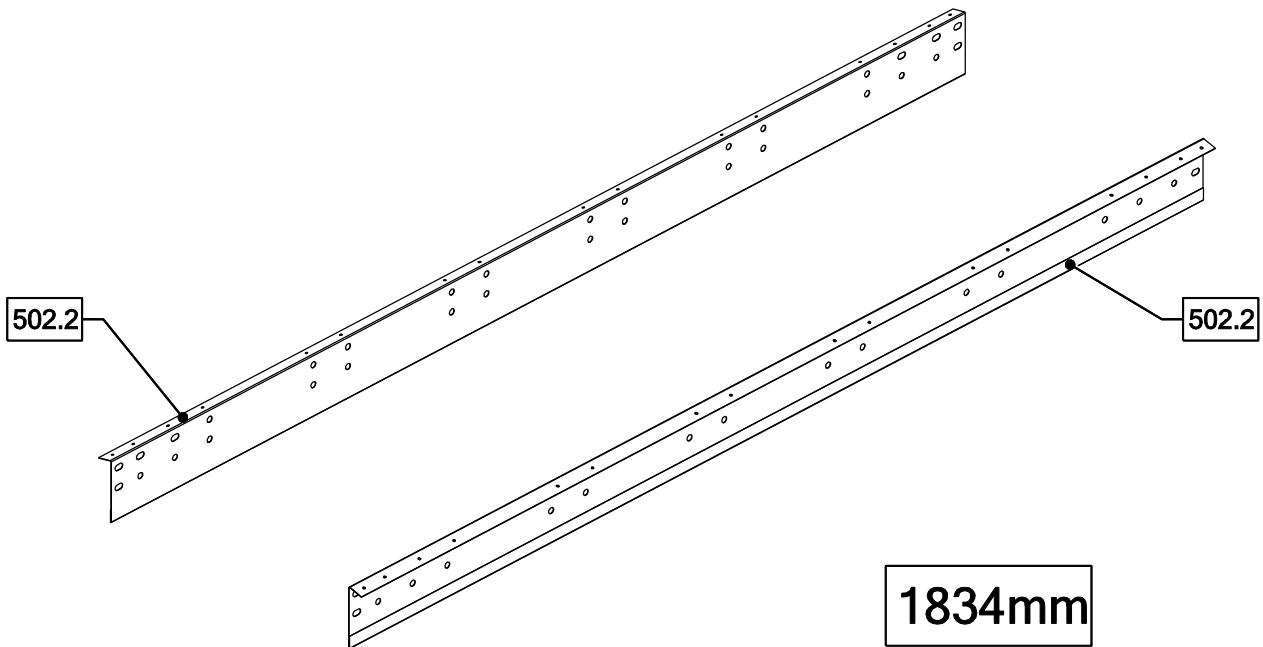
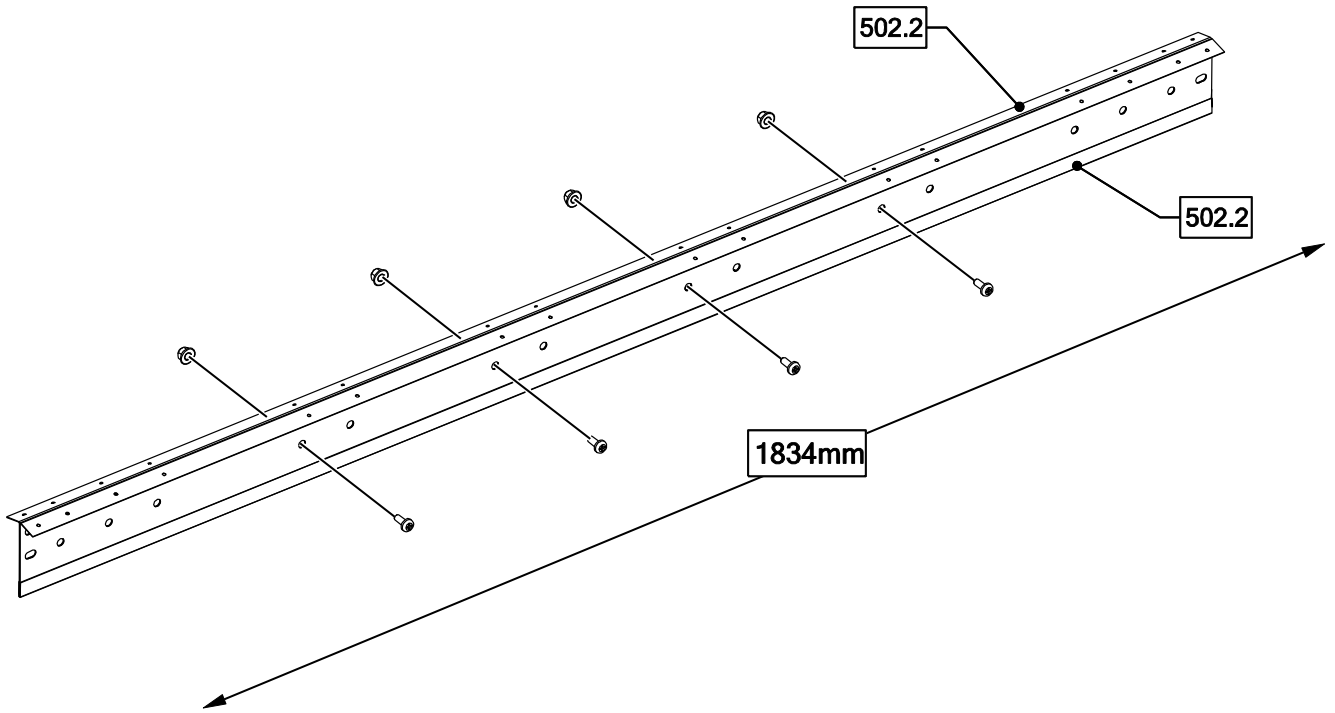
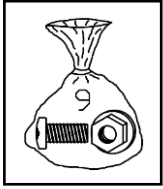

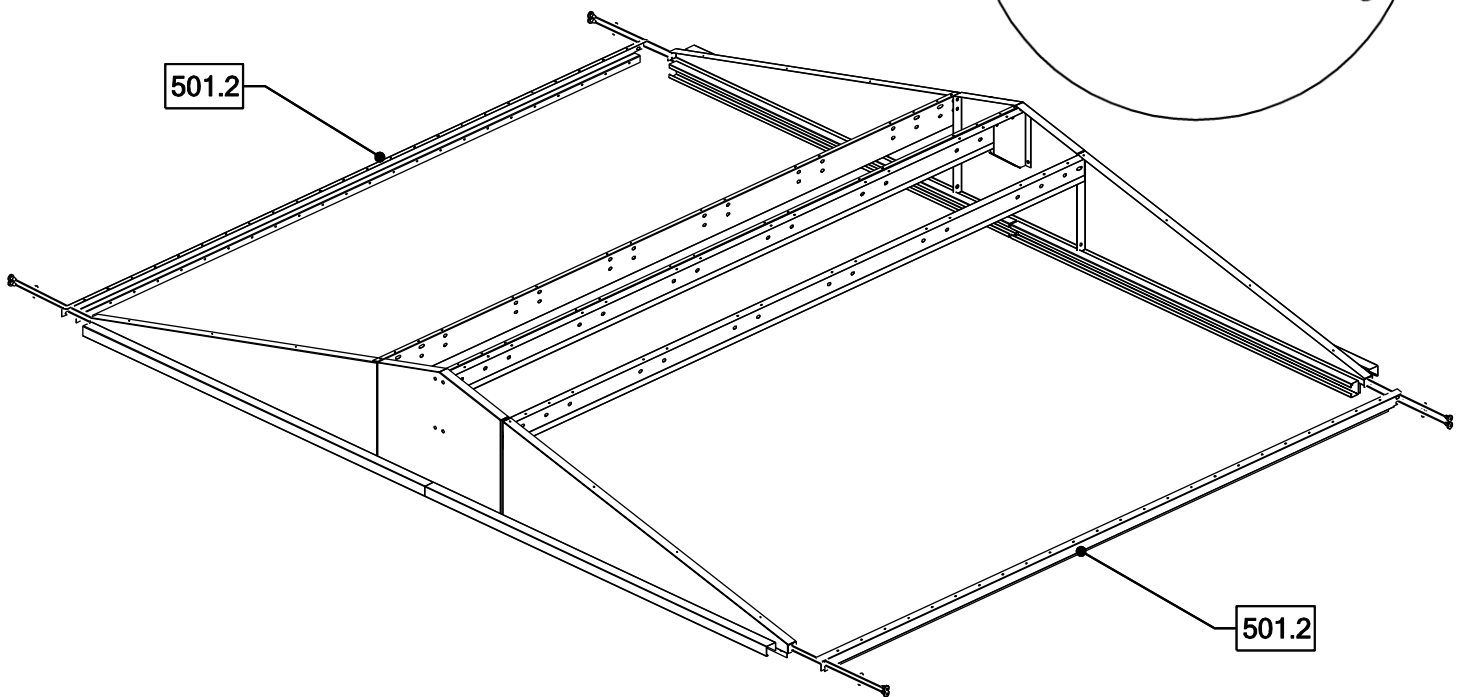
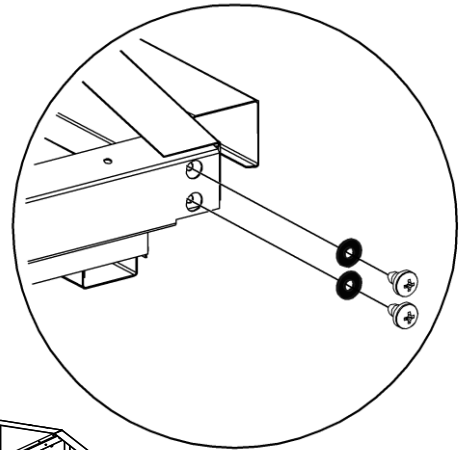
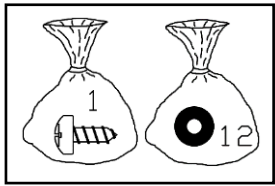
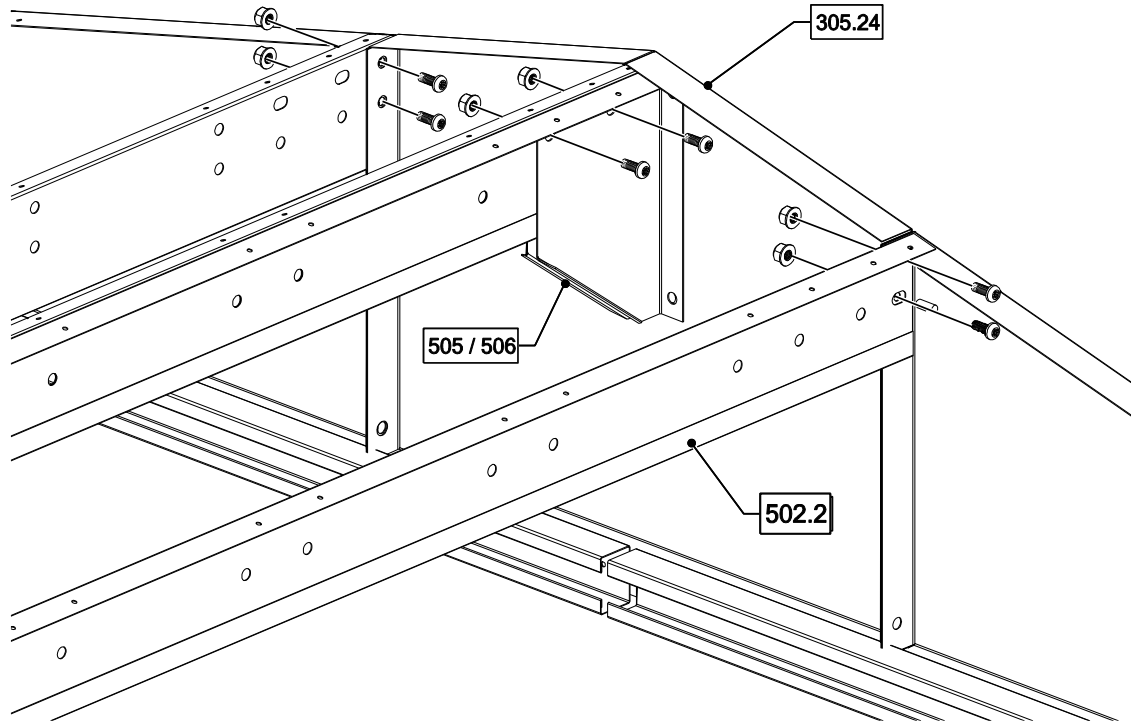
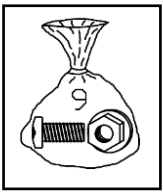

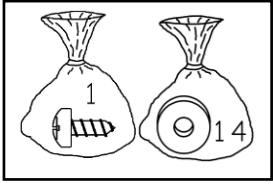

204.23

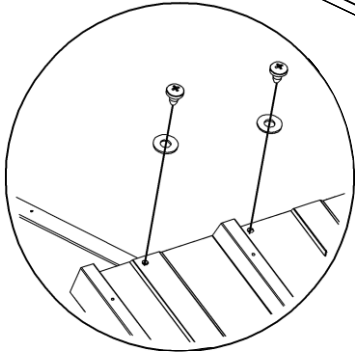
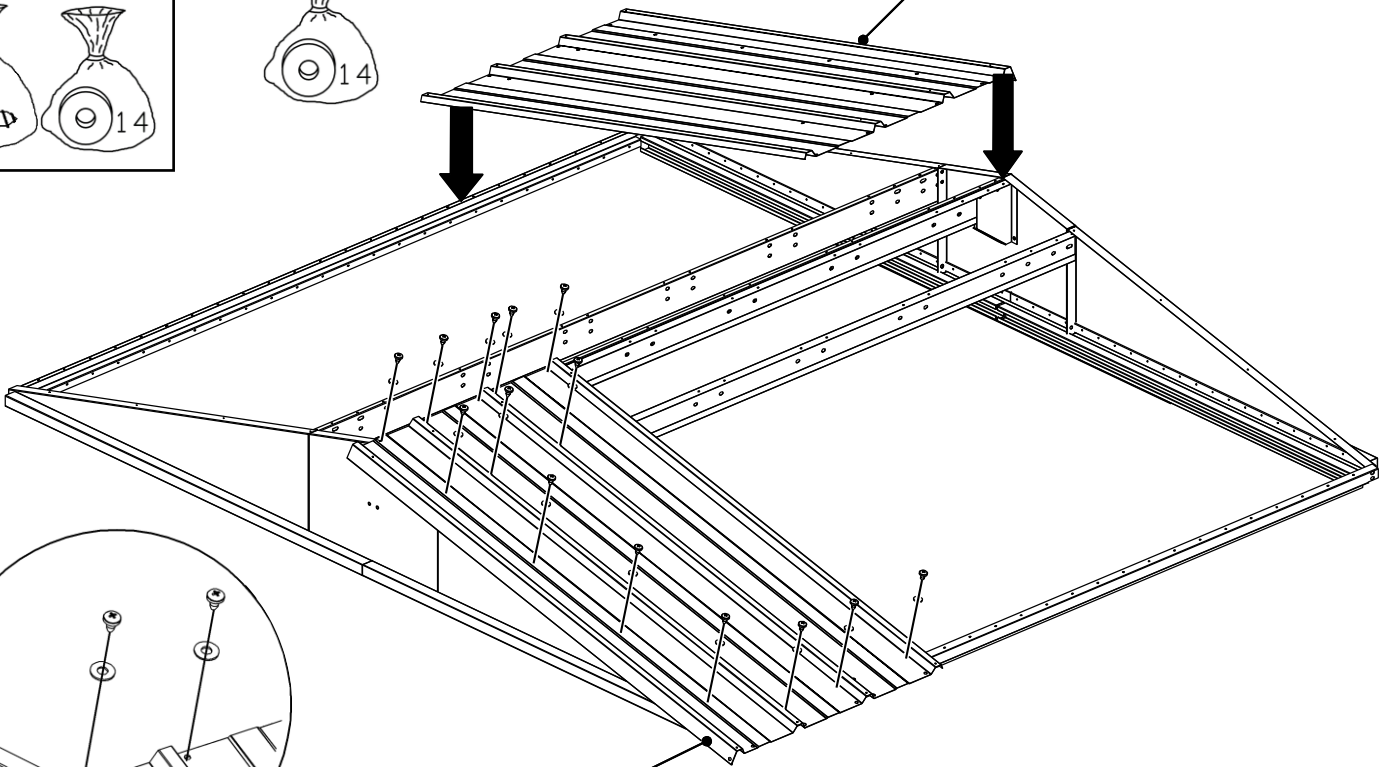

204.23

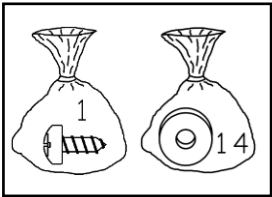

203.23

203.23

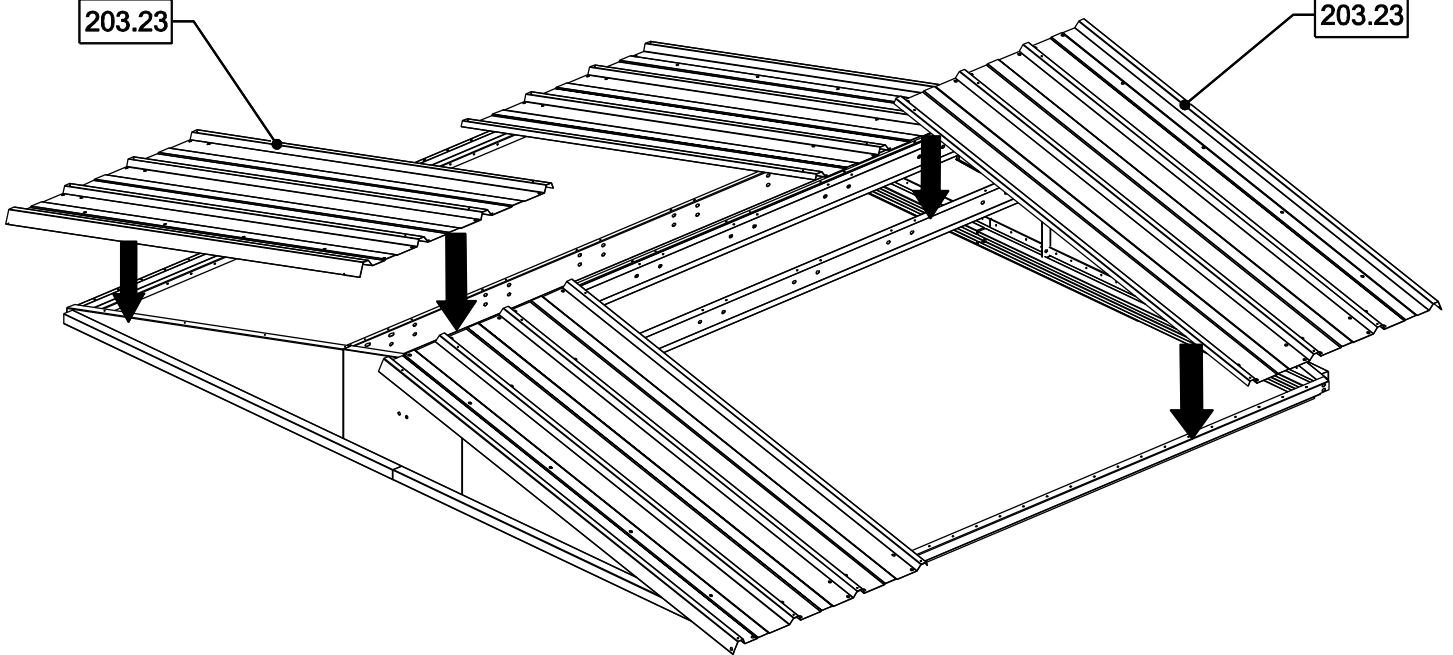

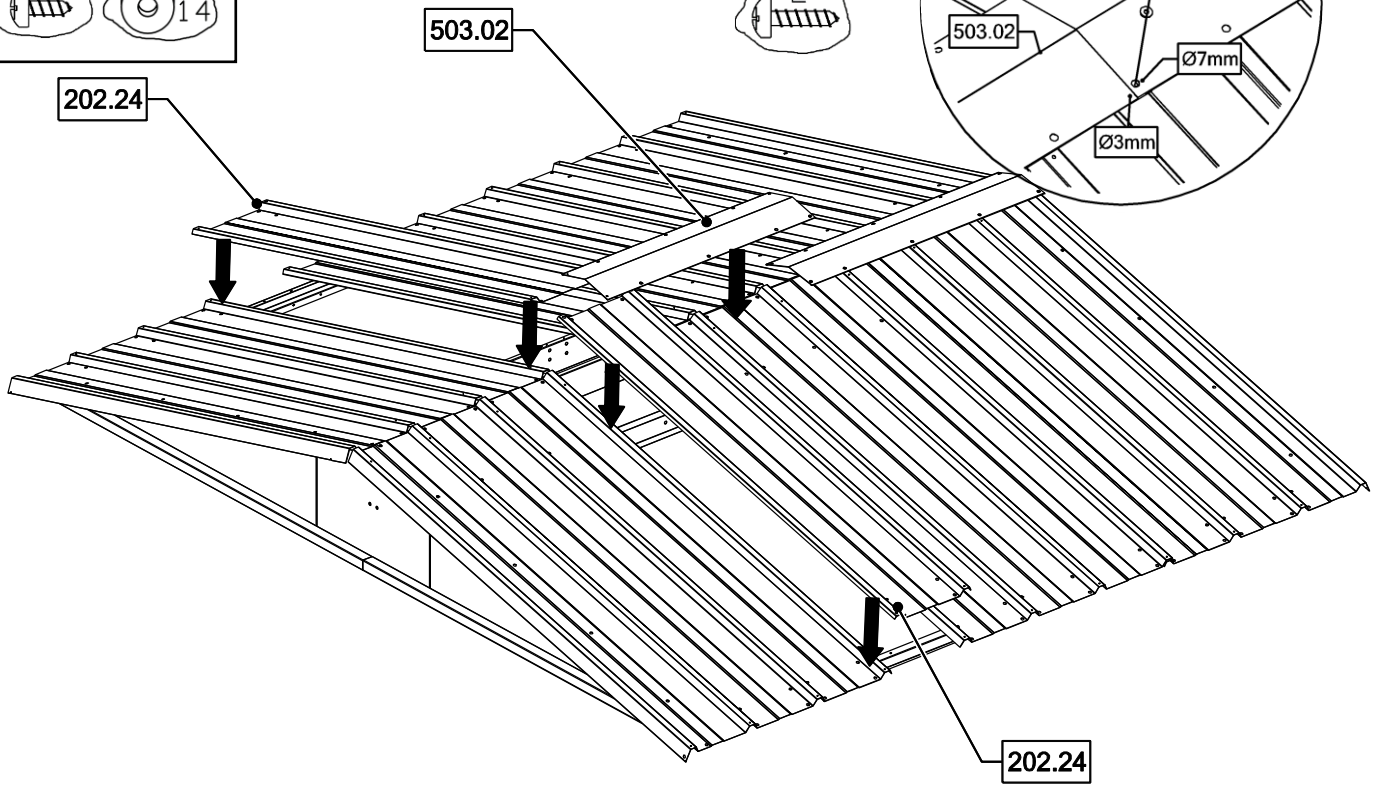
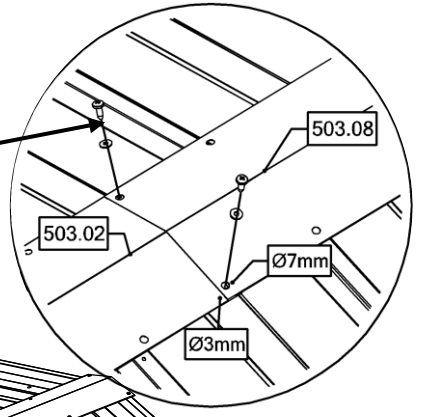
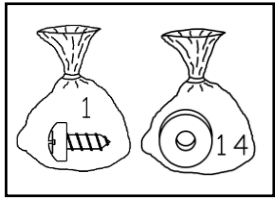
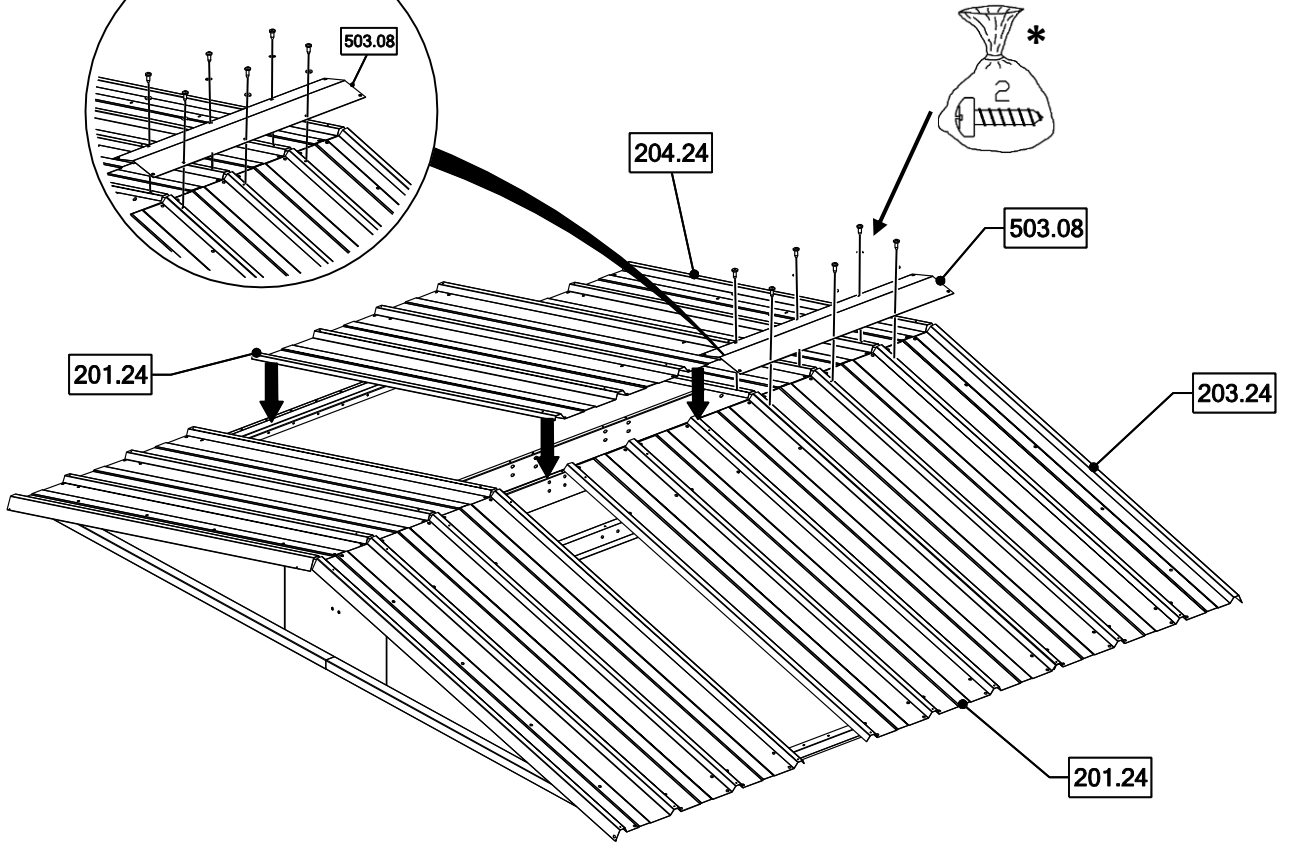
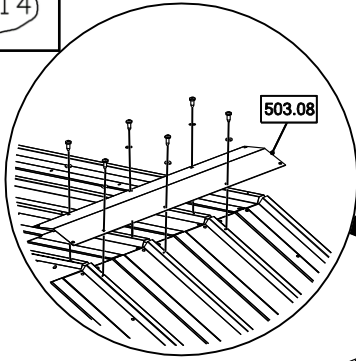
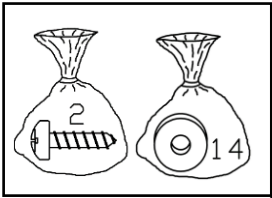

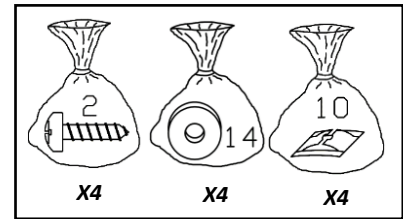
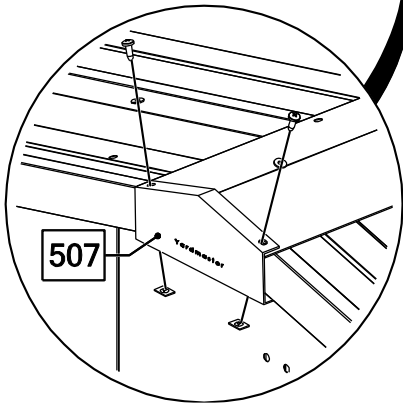
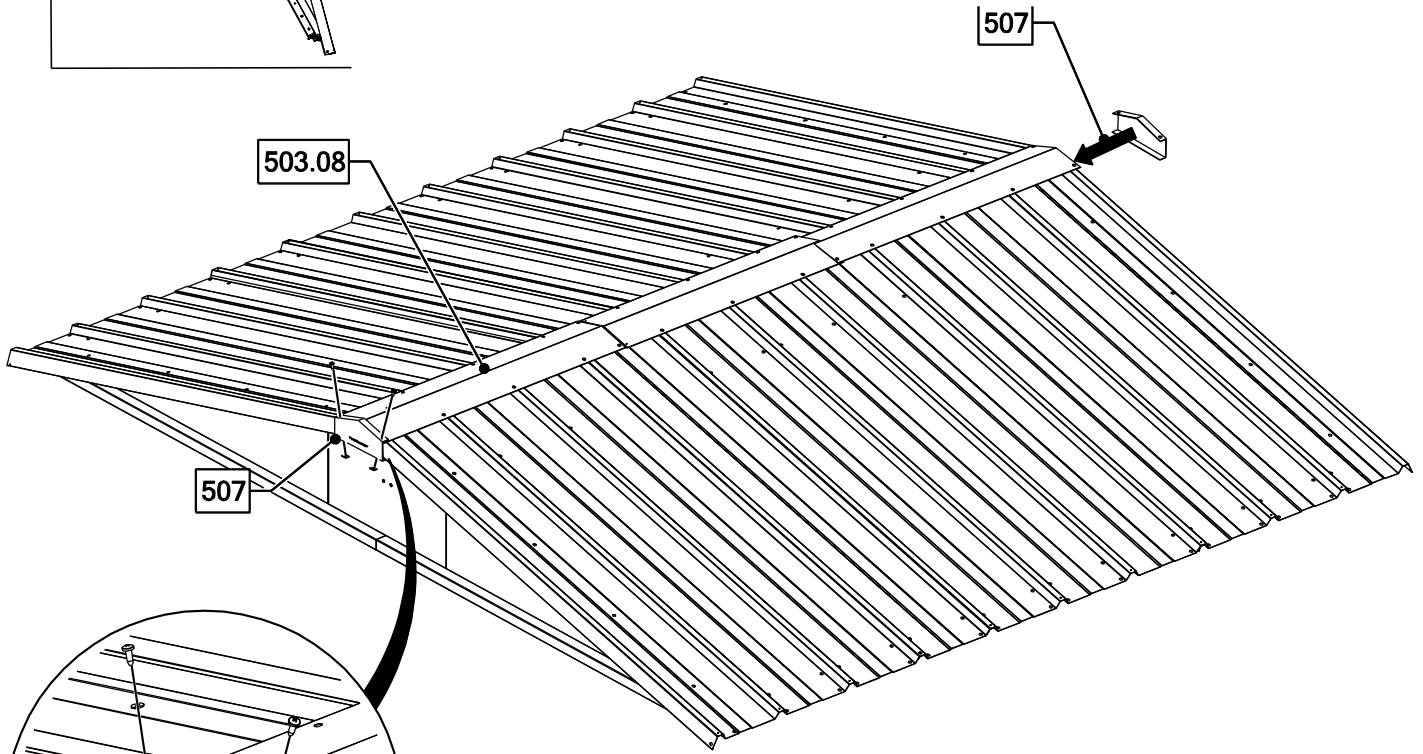
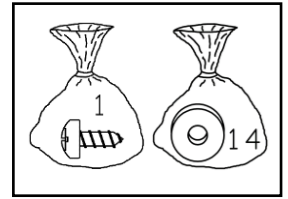
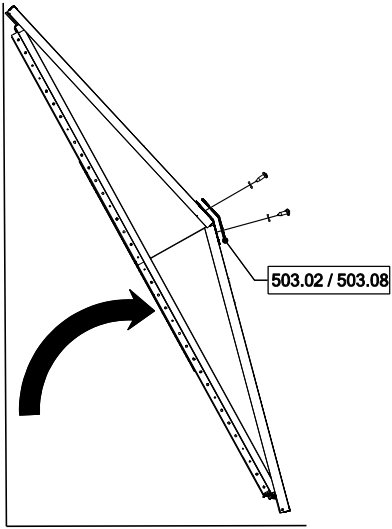

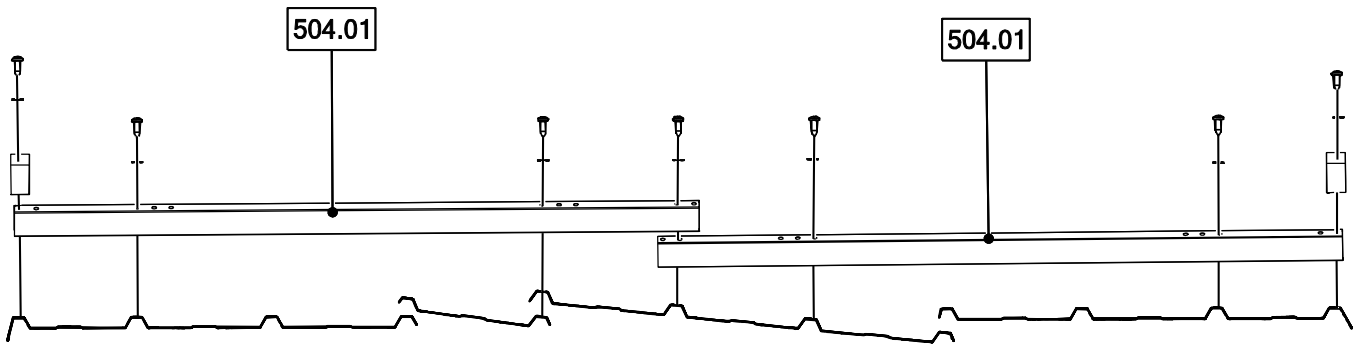
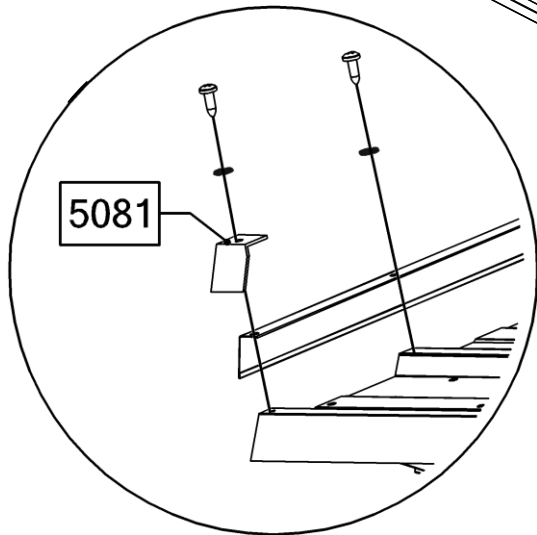
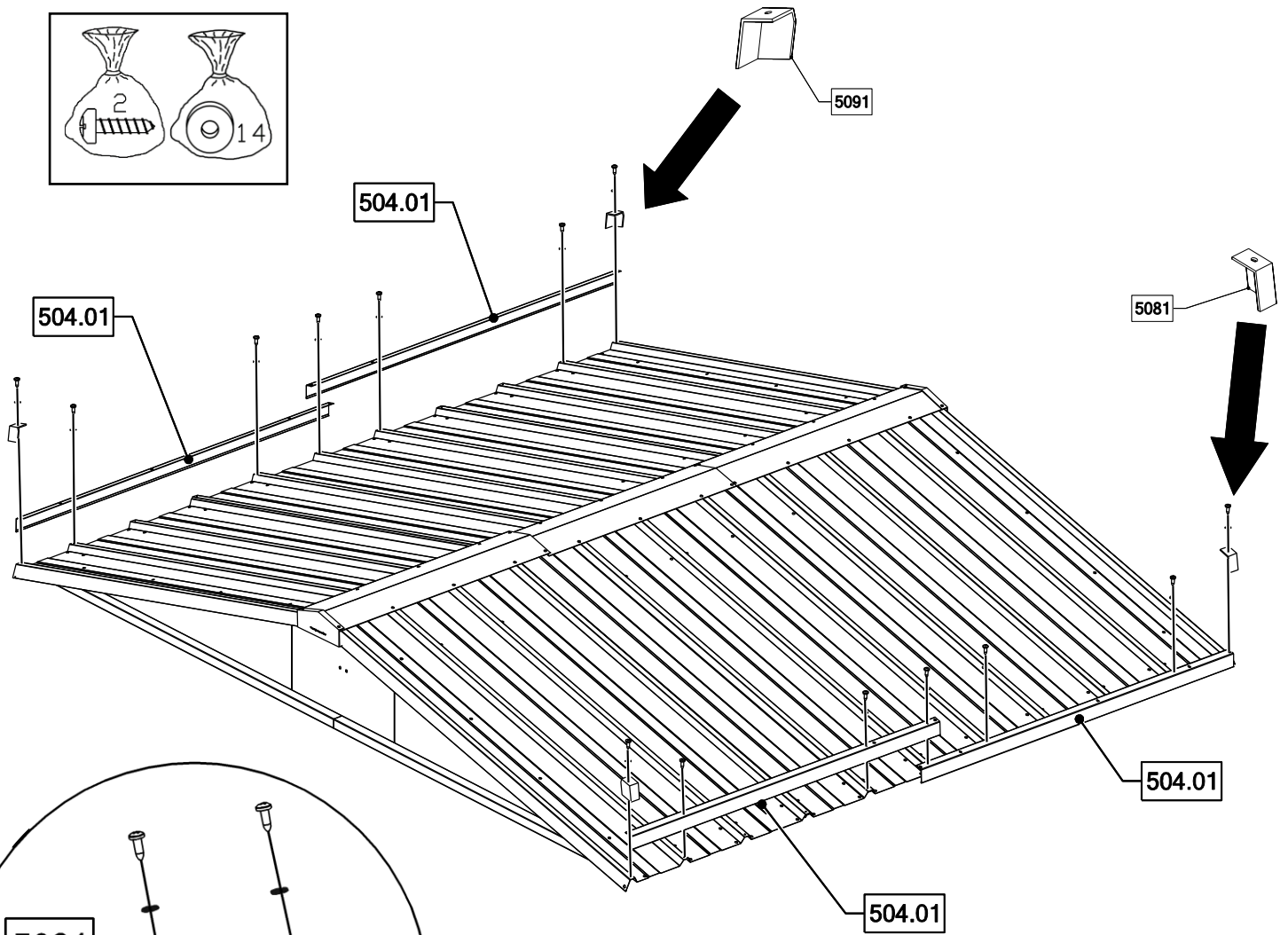
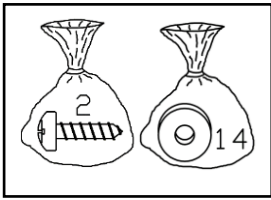

204.23

202.24

201.24

203.23

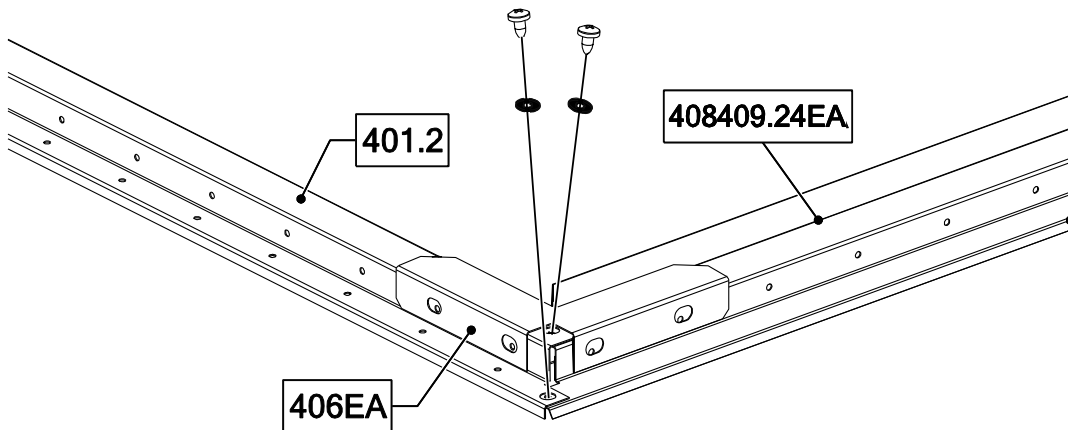
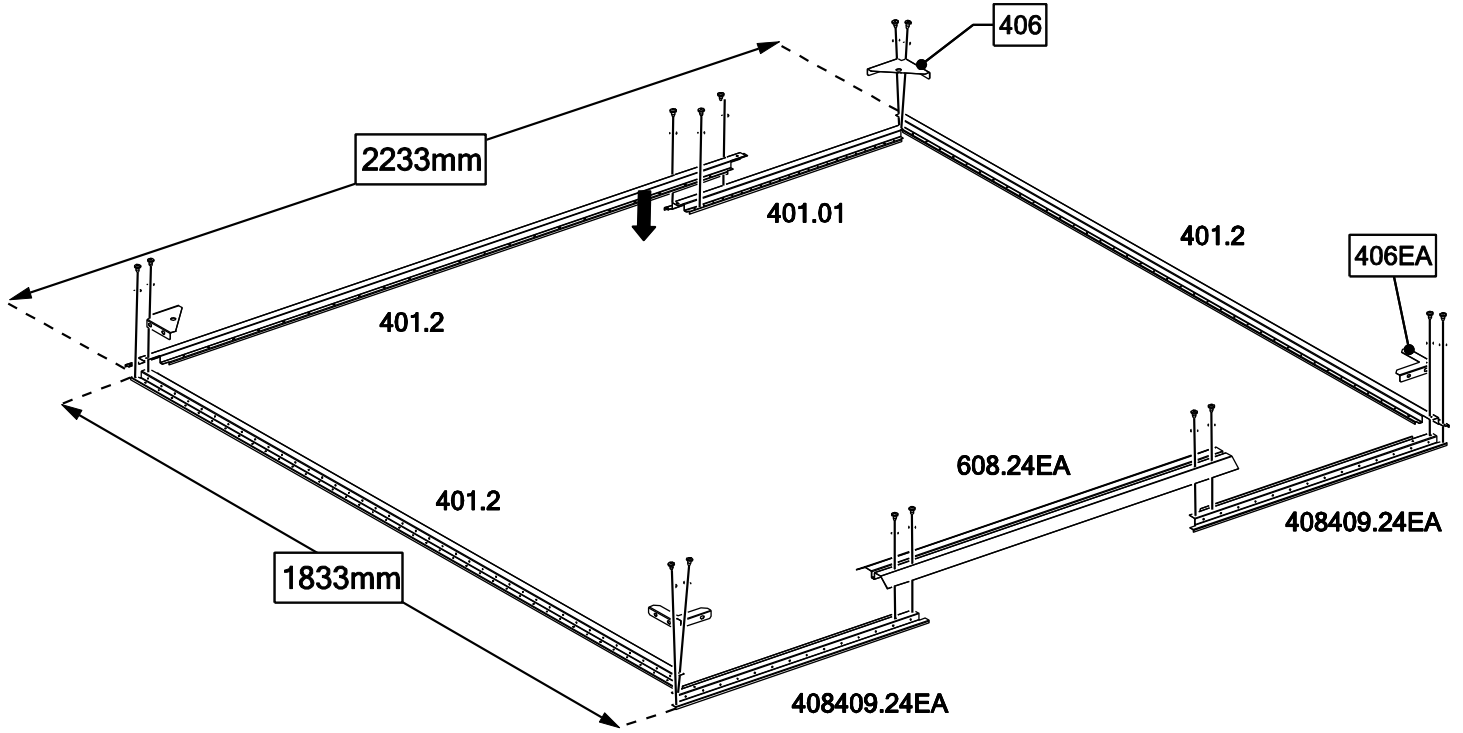
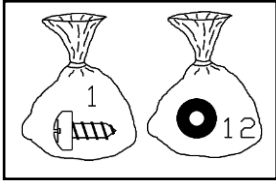
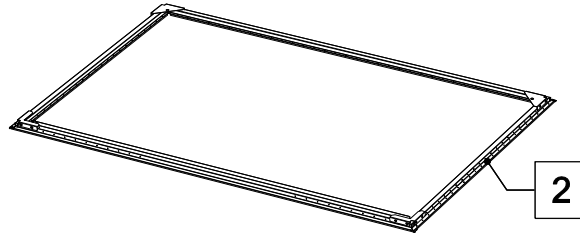

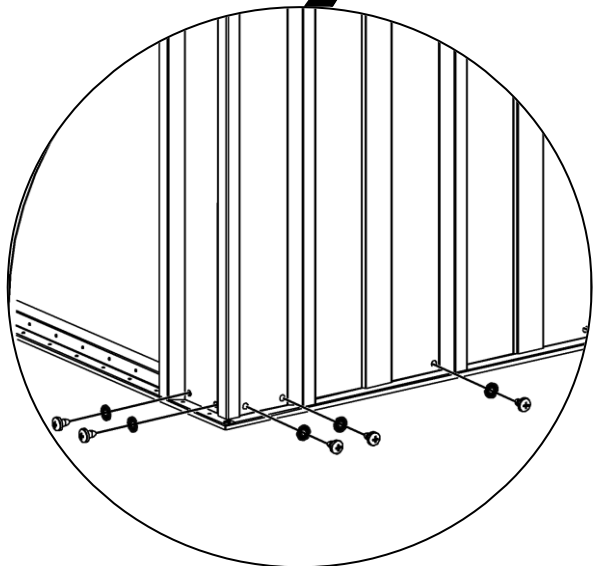
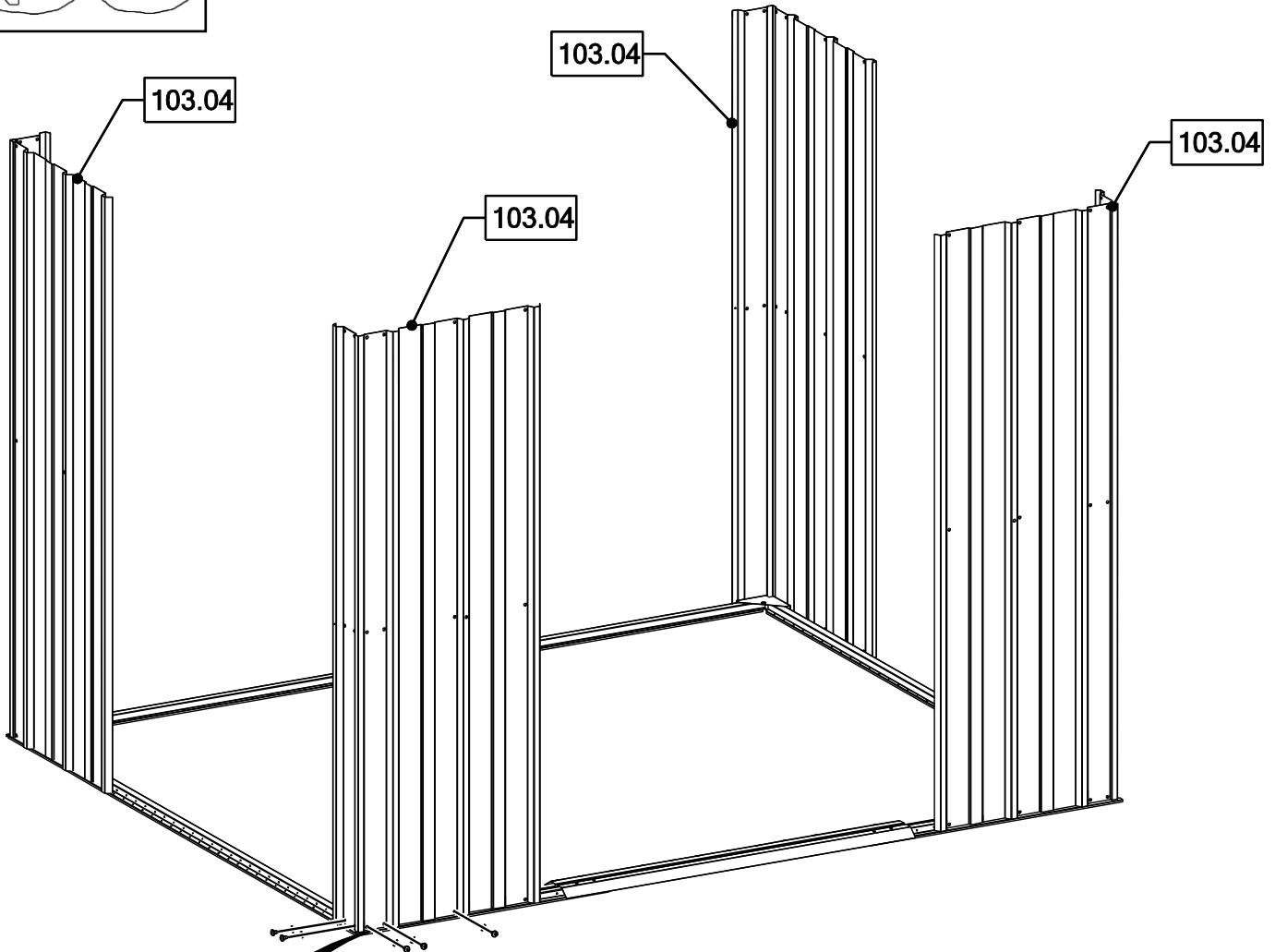
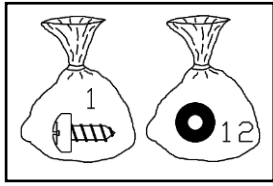
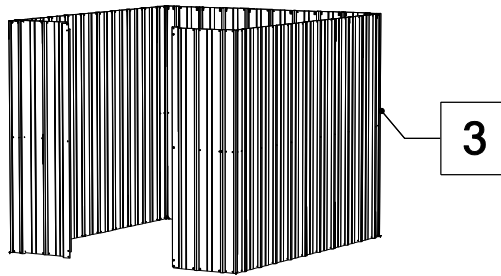

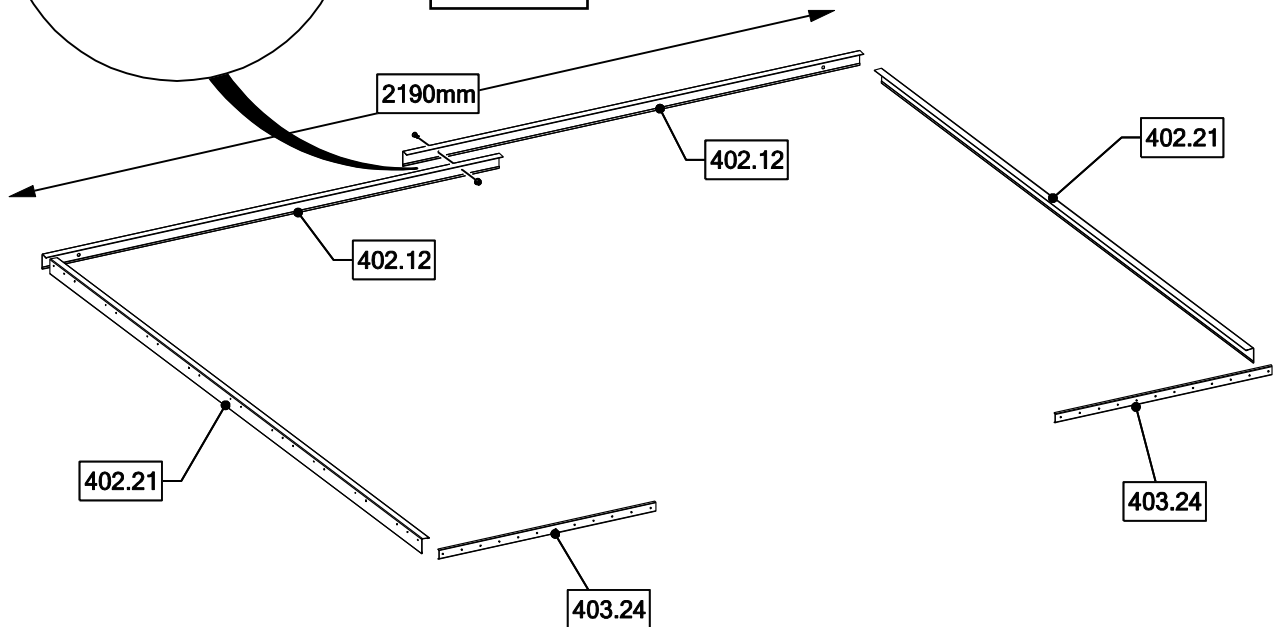
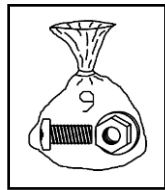
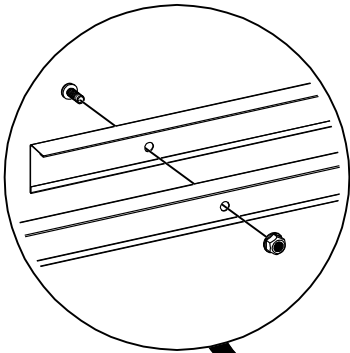
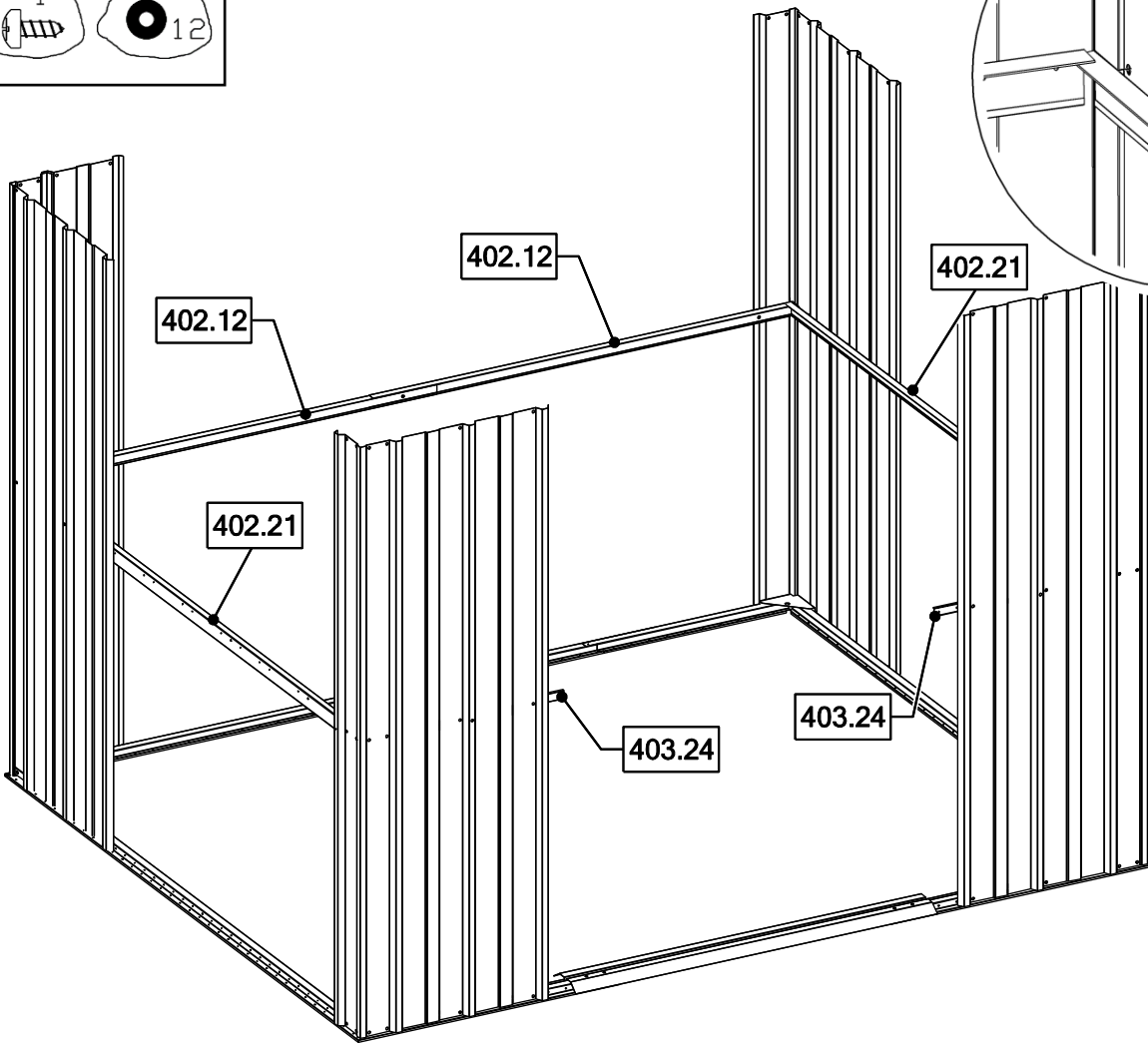
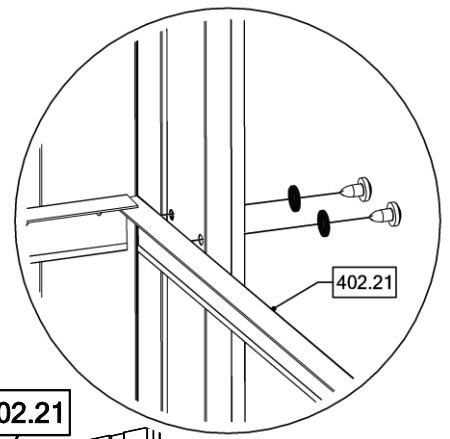
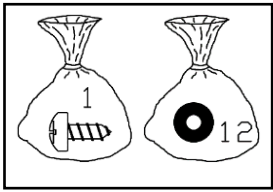

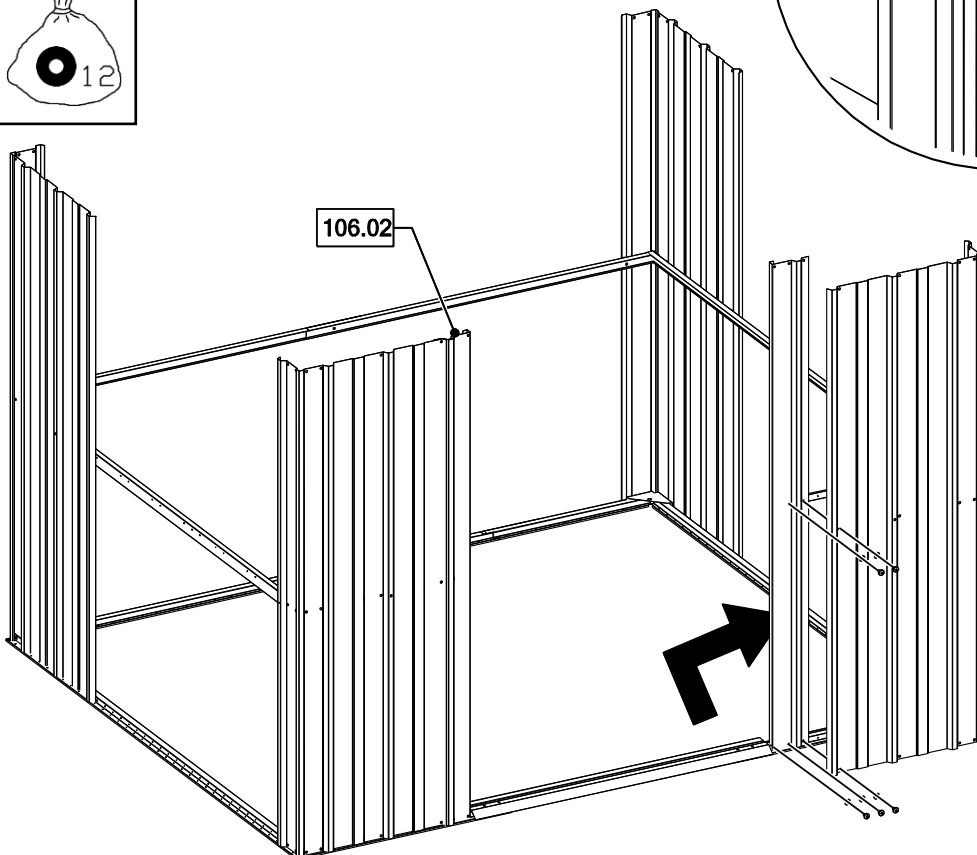
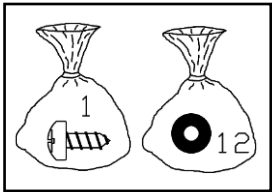
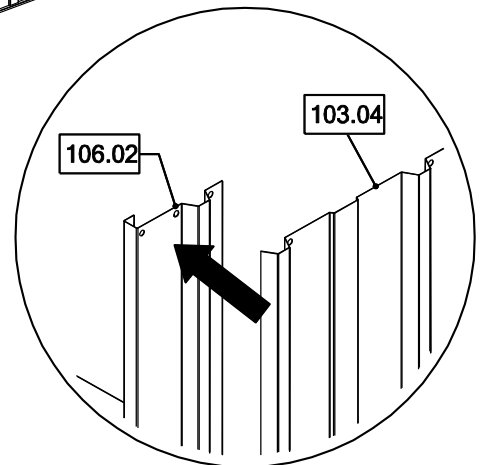
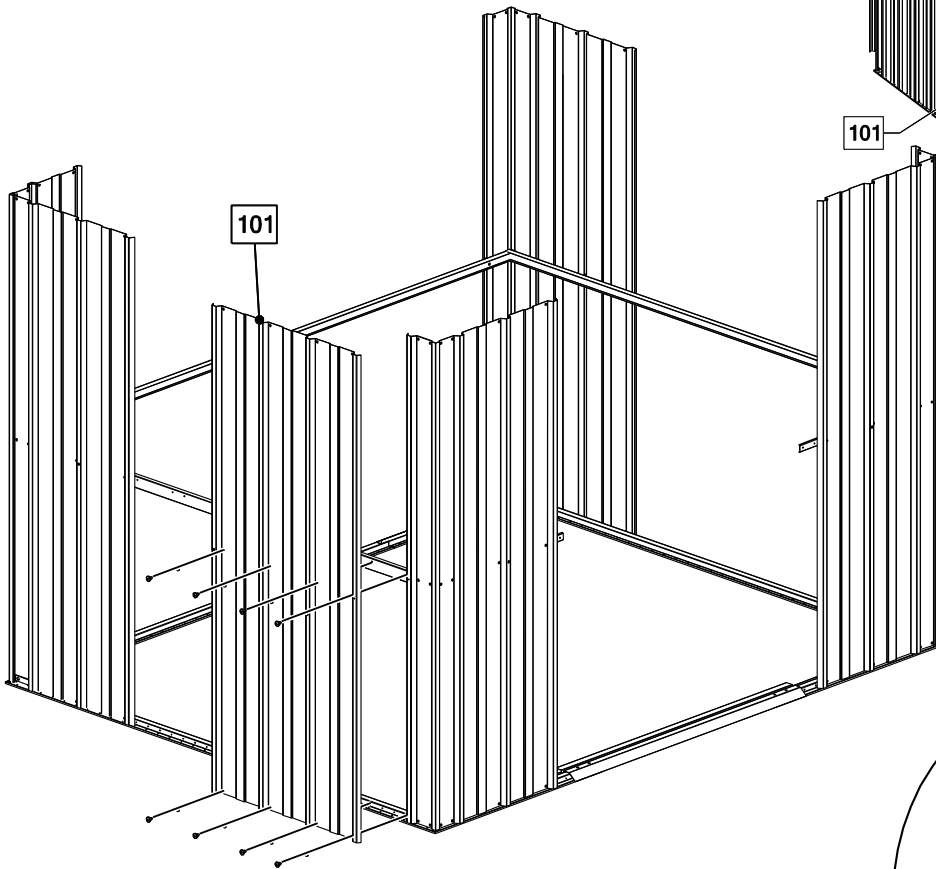
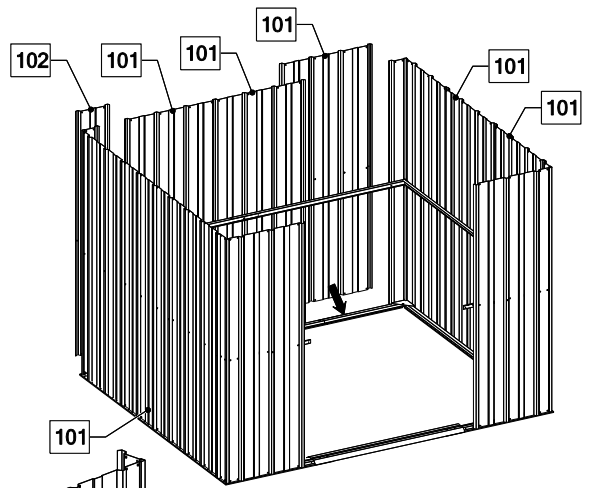
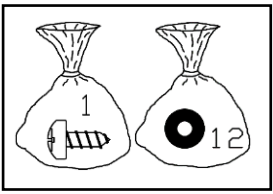

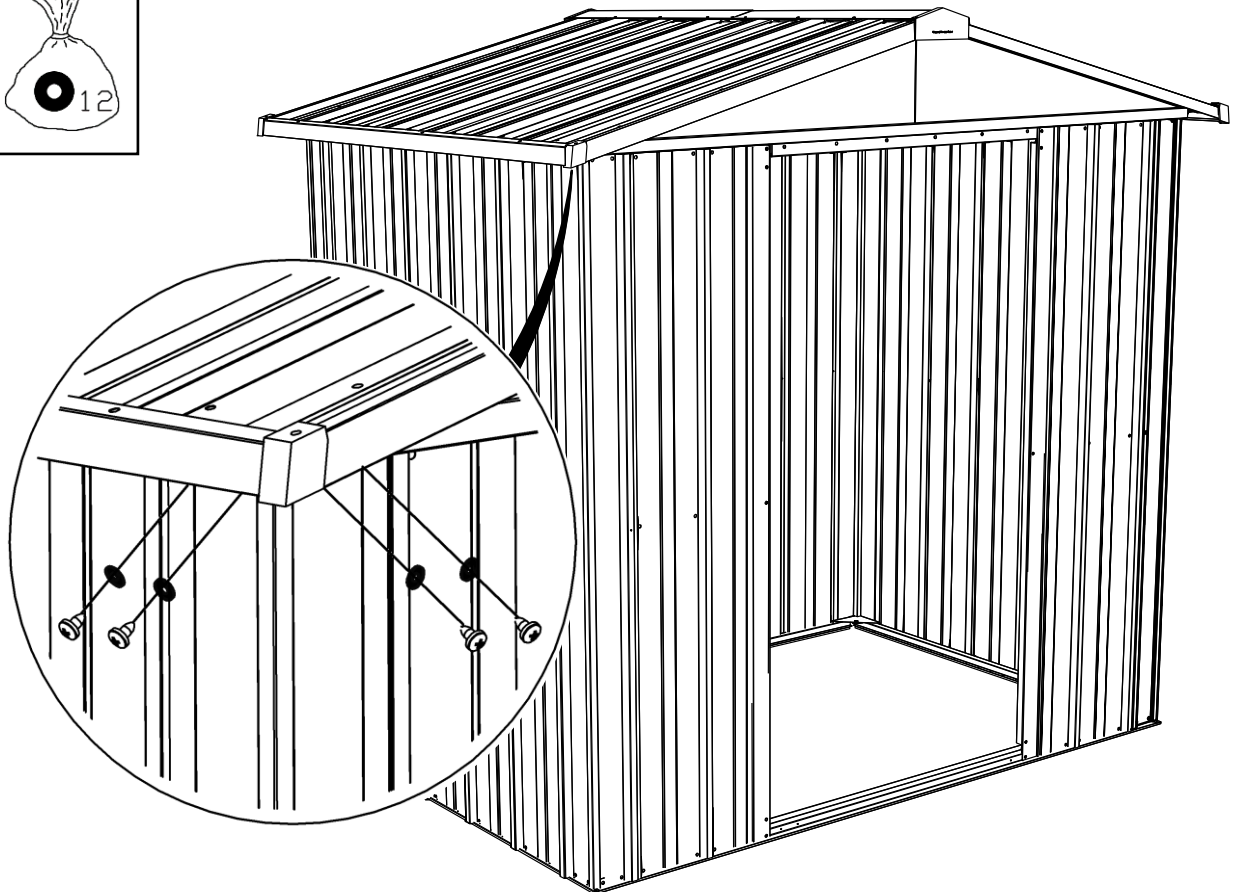
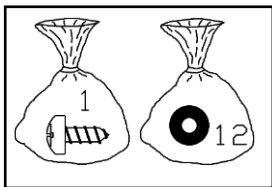
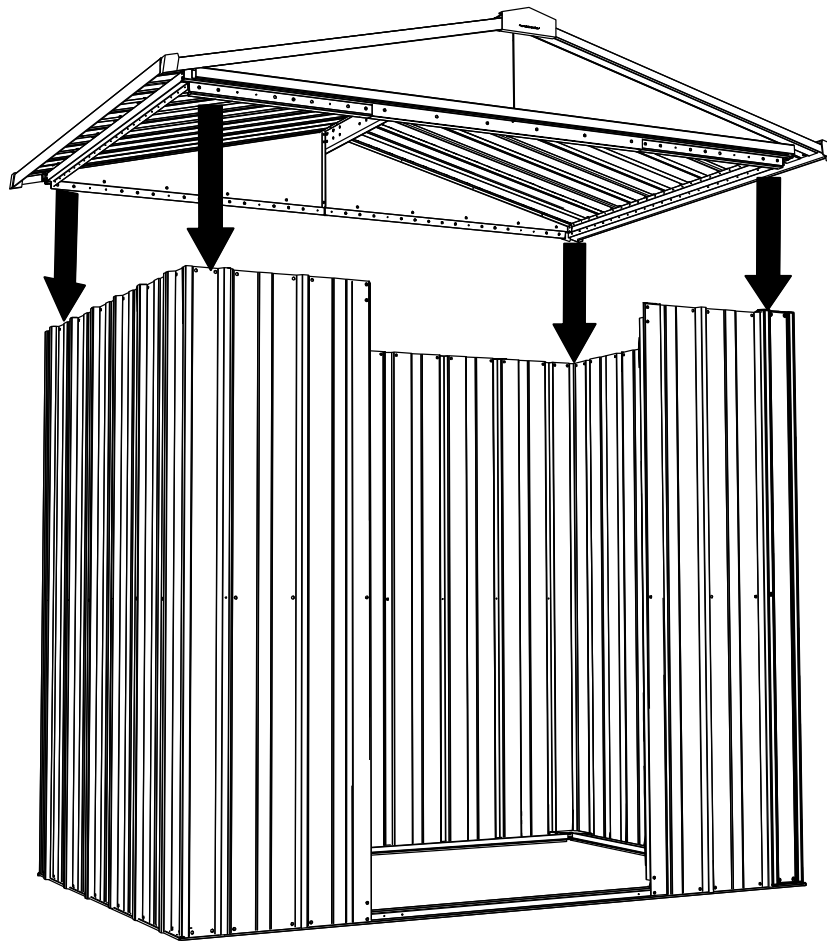

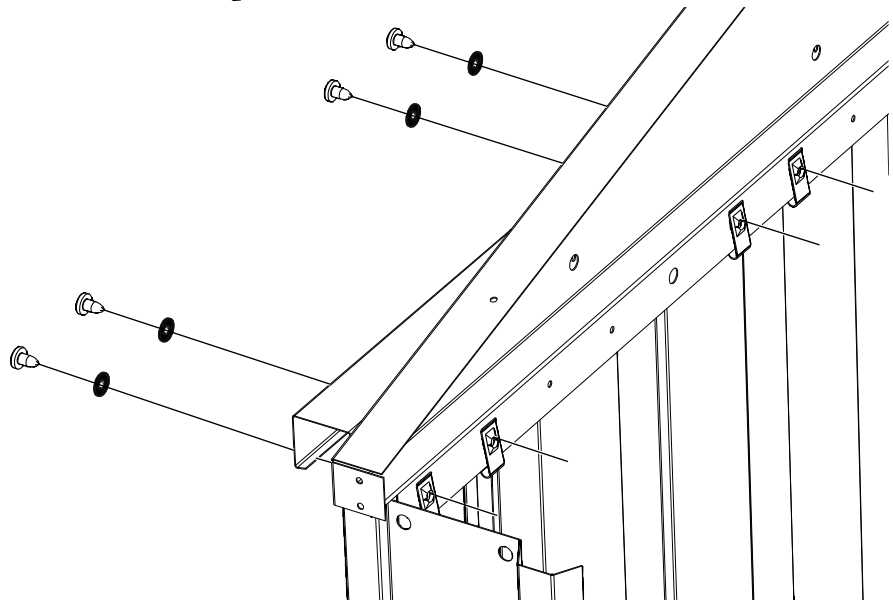
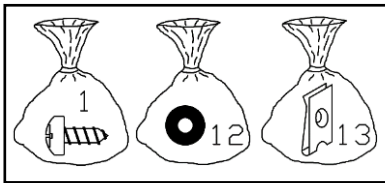
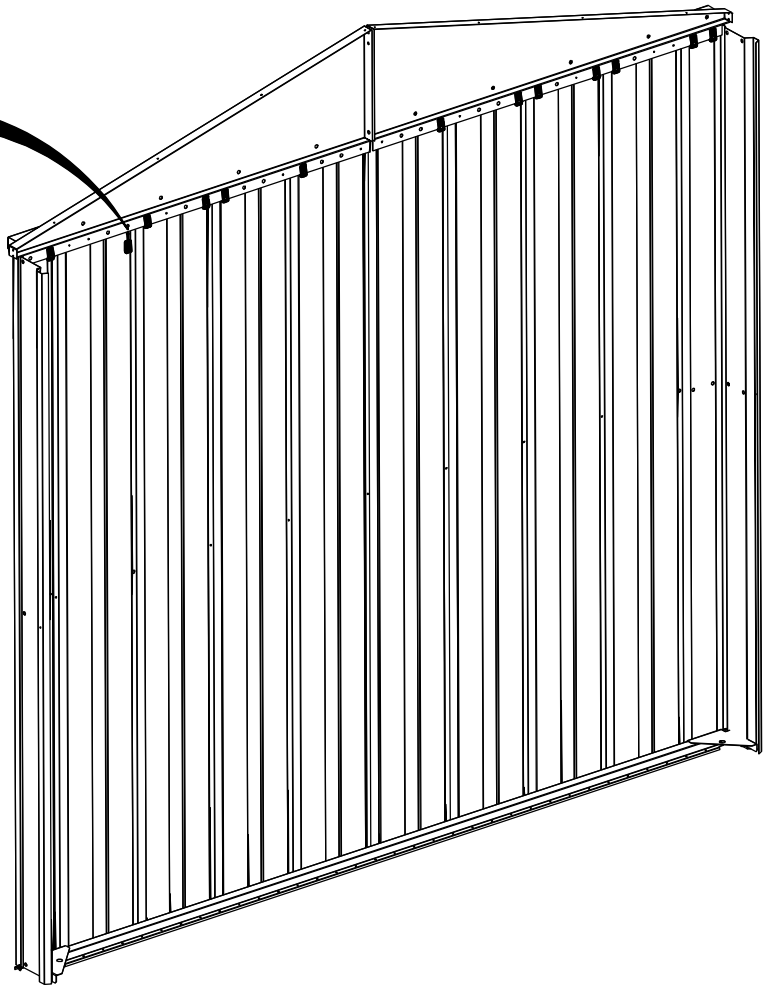
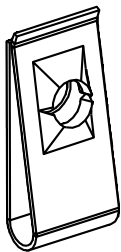
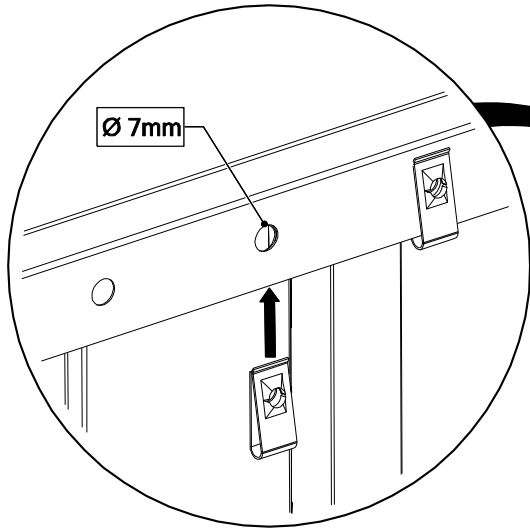
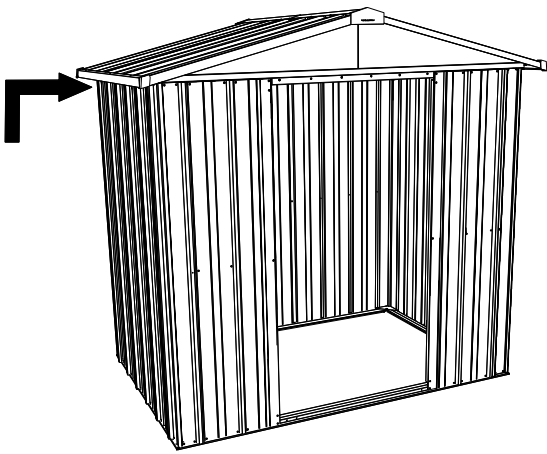

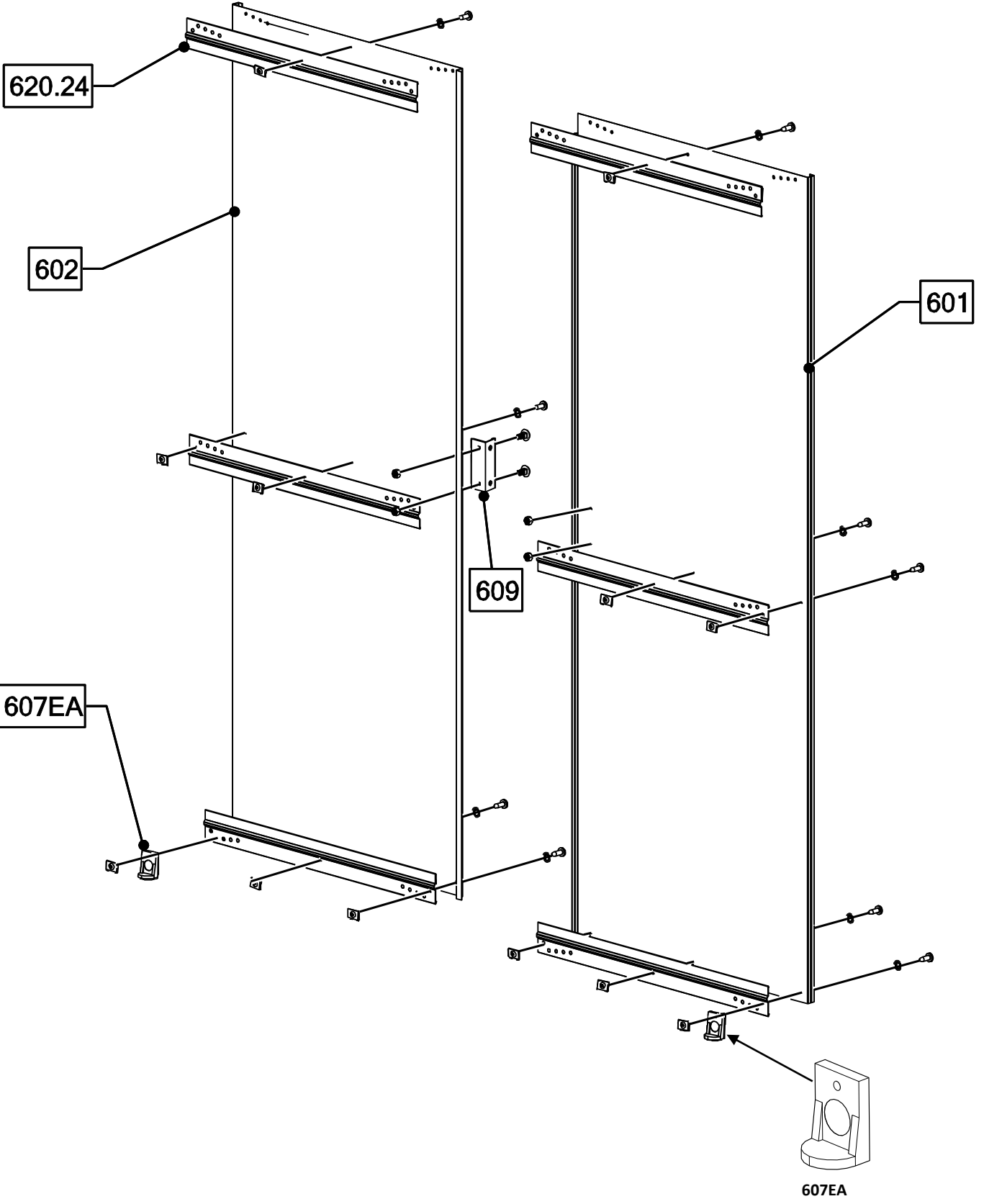
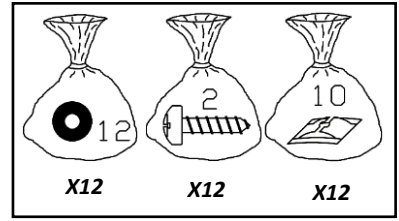
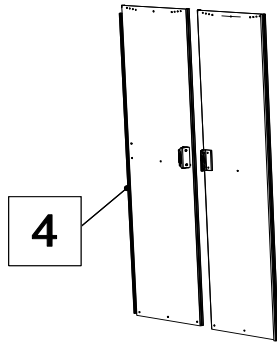

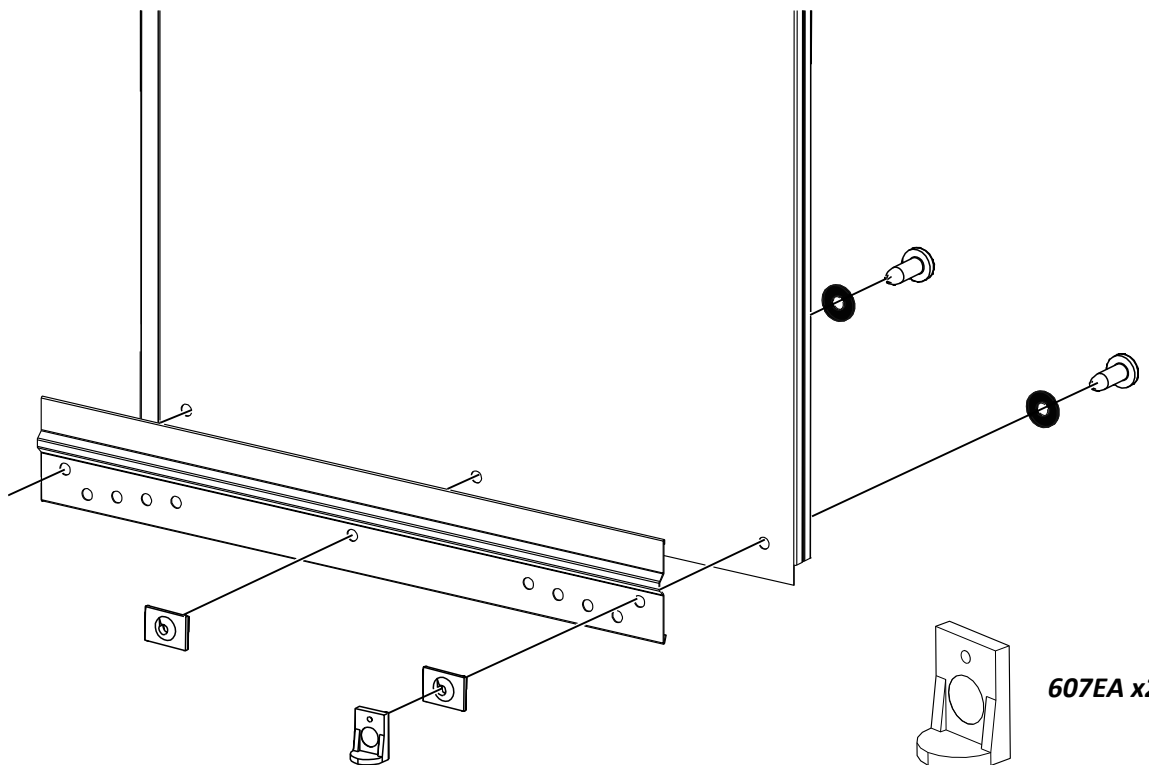
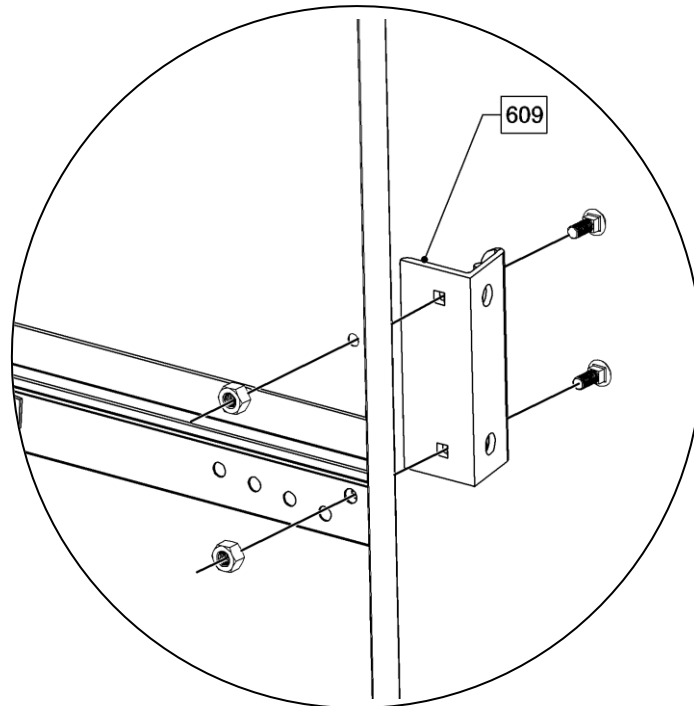
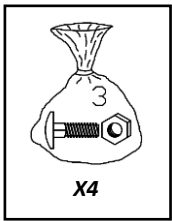
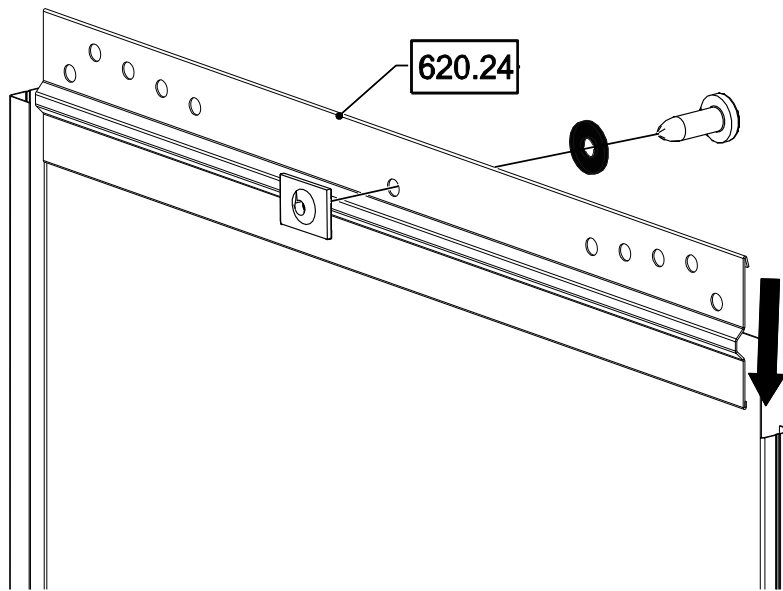

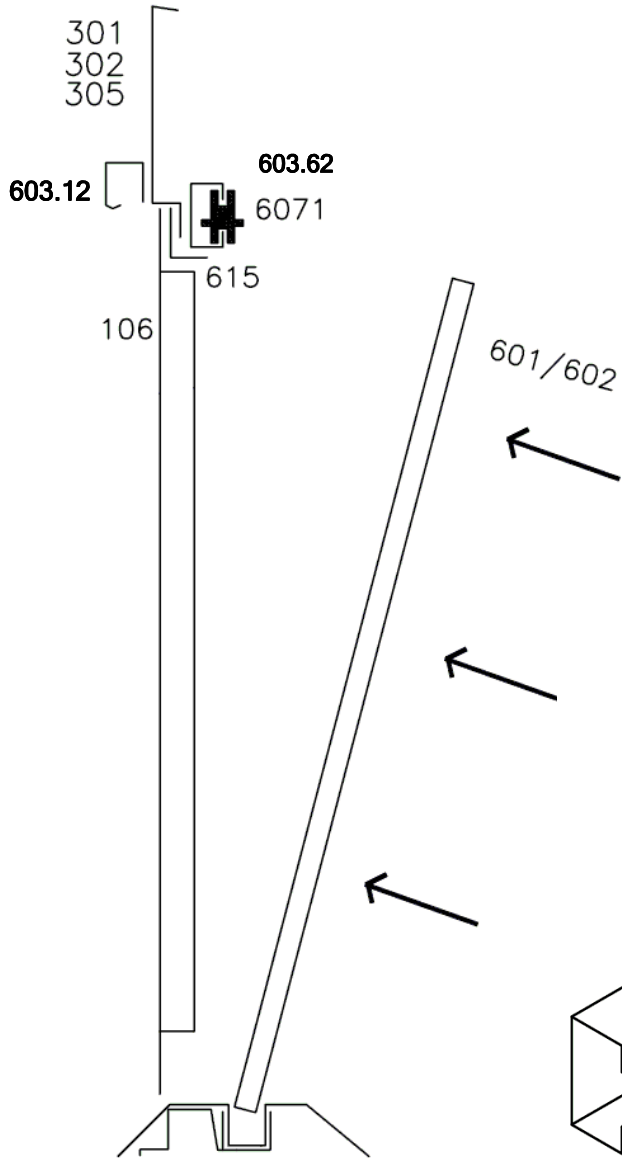
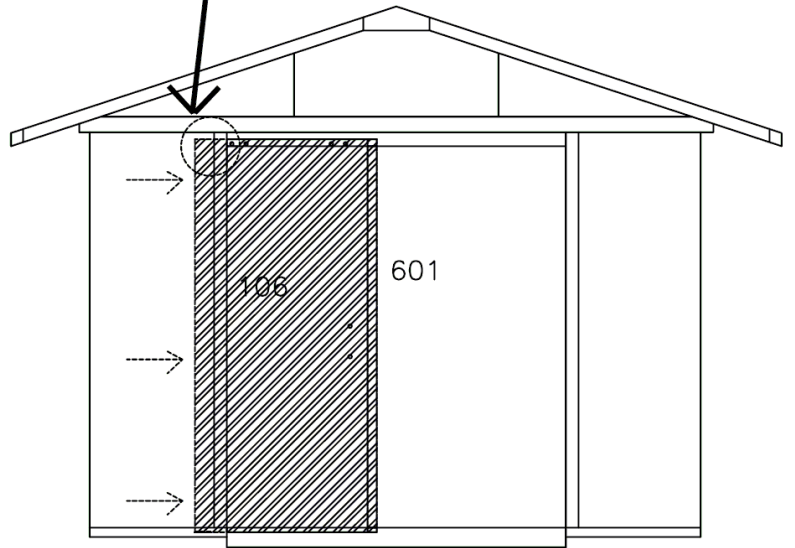
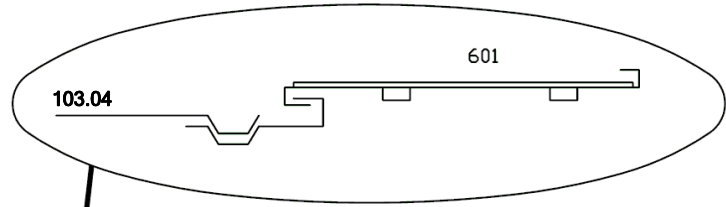
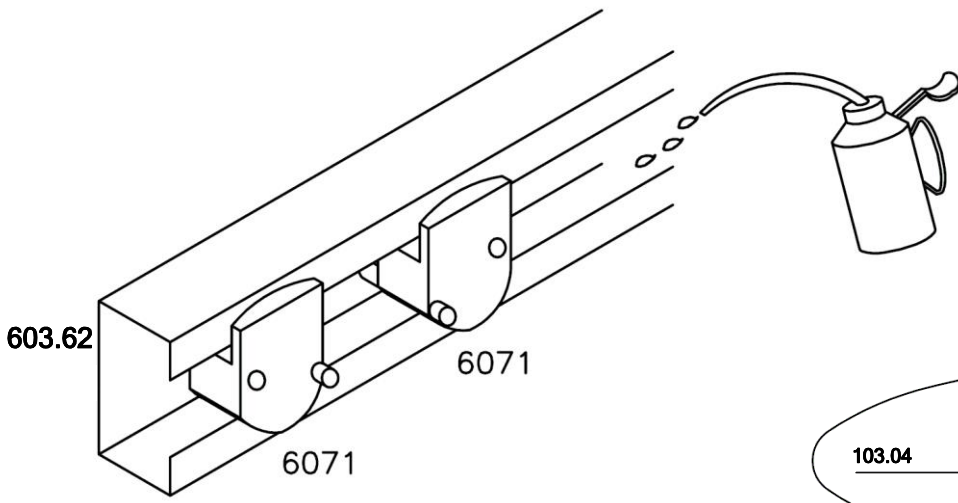

408409.24EA

