

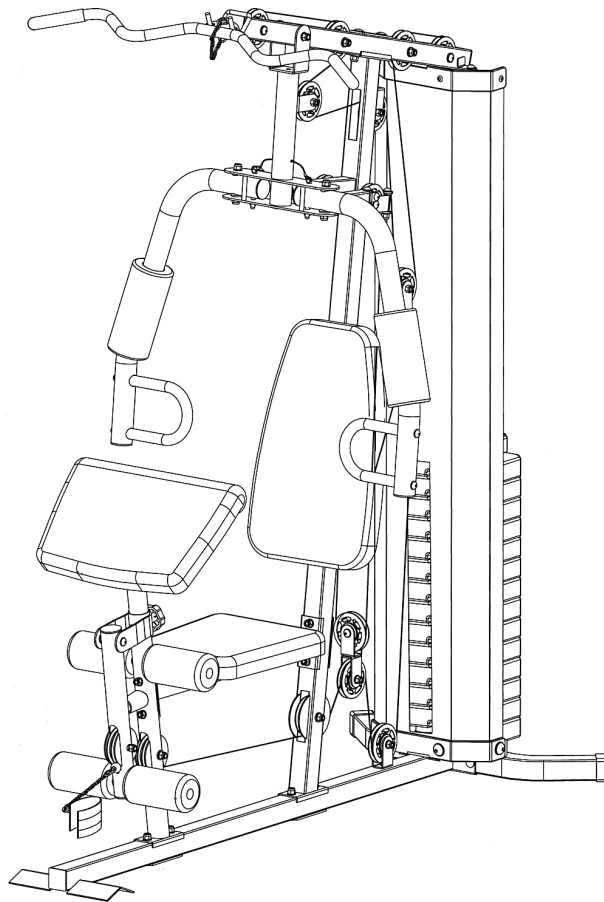

MARCY

MARCY[®] ECLIPSE HG3000 COMPACT HOME GYM



IMPORTANT: Please read the Important Safety Notice and Assembly Information in the Owner's manual before assembling this product.

Assembly Manual

010114

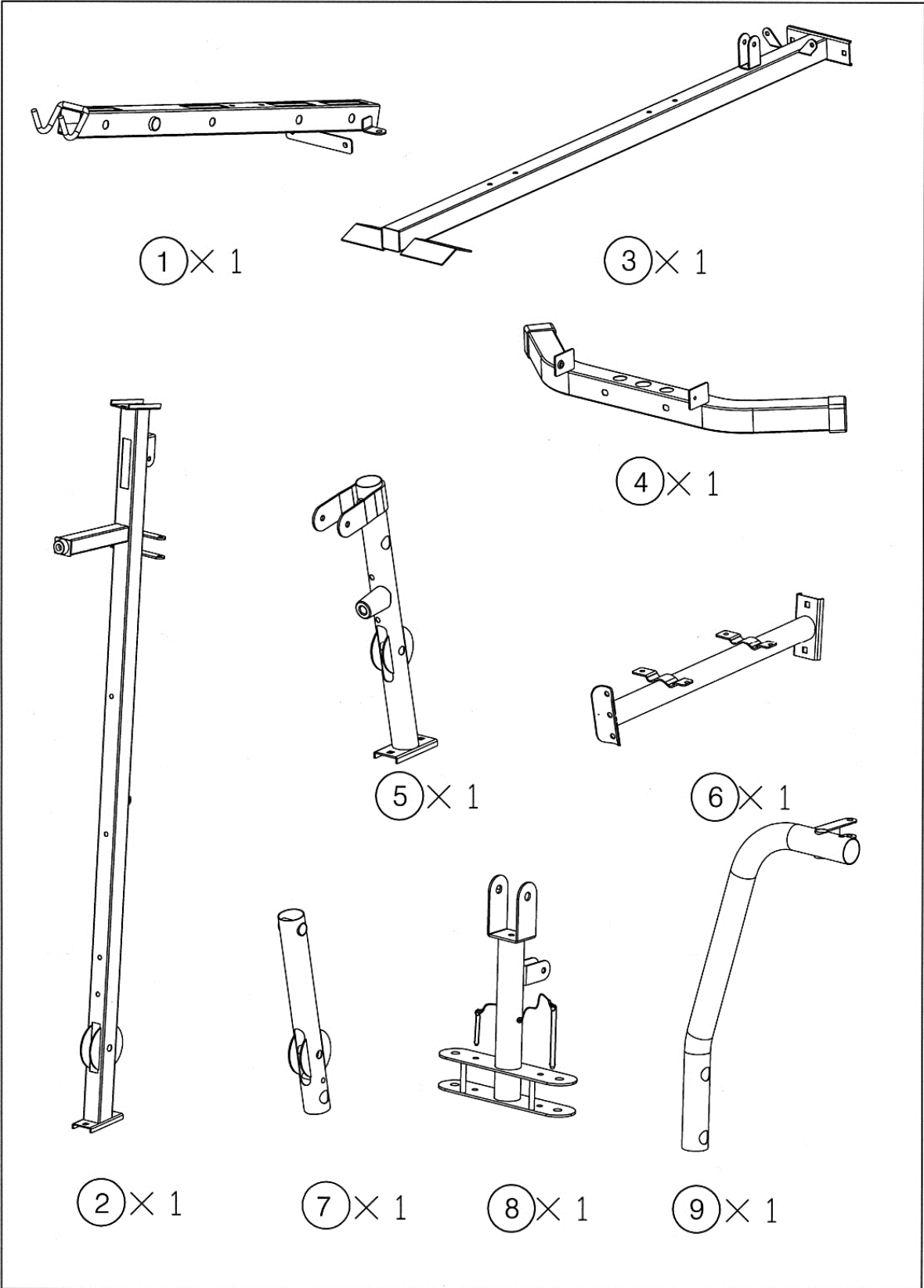

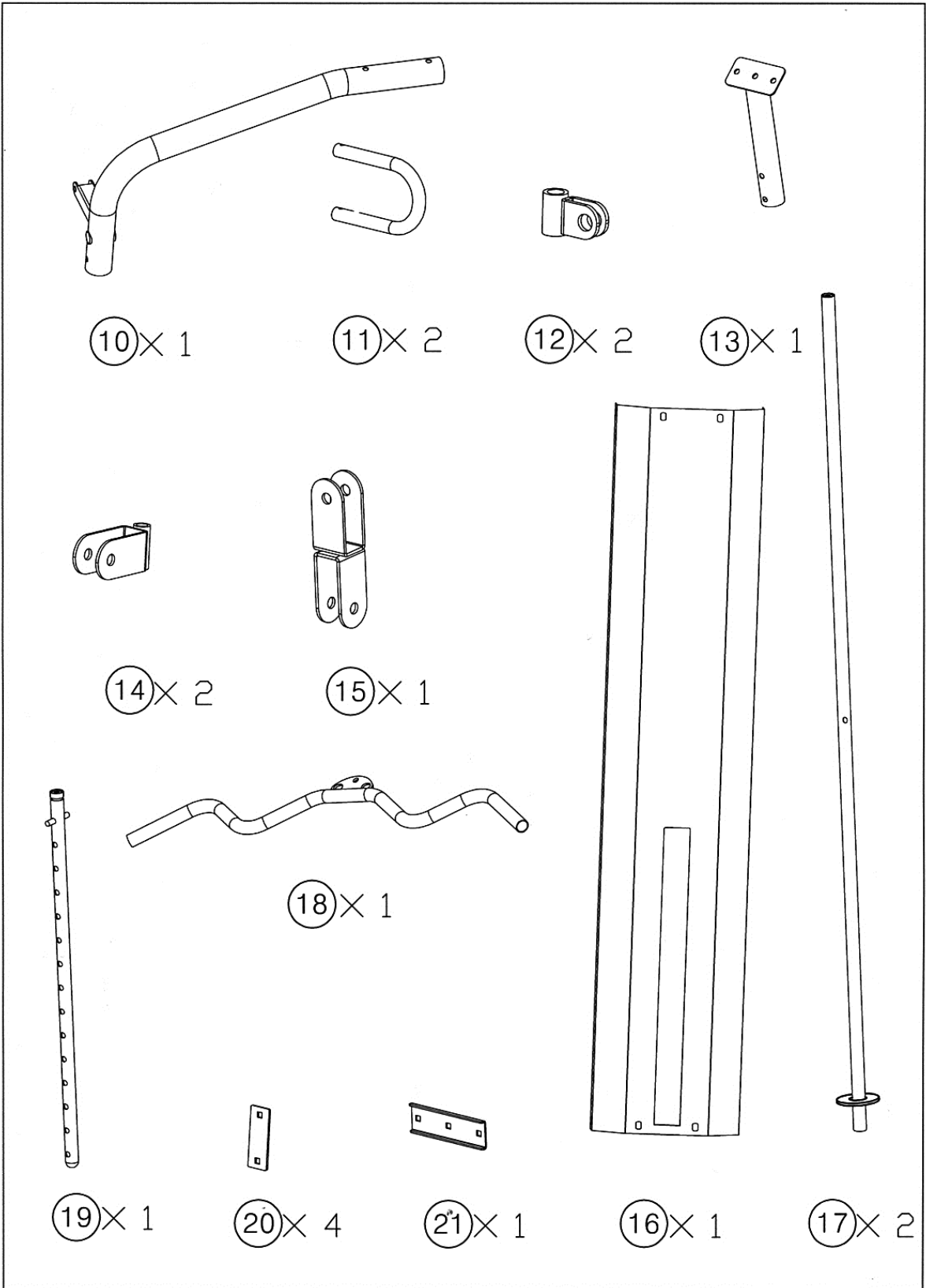



22 × 1



23 × 2

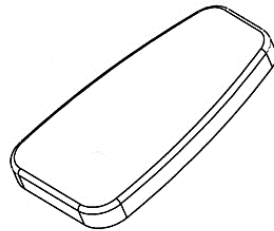

24 × 1

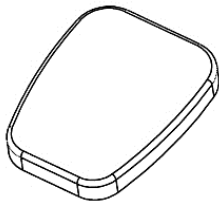

25 × 1

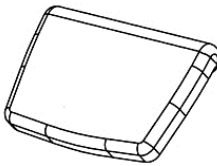

26 × 1



27 × 2

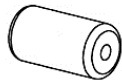

28 × 4

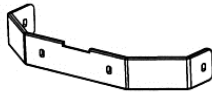

29 × 2

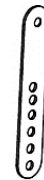

30 × 2

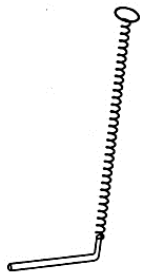

32 × 1

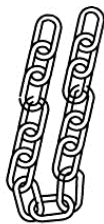

33 × 1



34 × 2

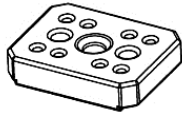

35 × 1

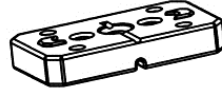

36 × 14



41 × 2



42 × 16



43 × 14



47 × 1



48 × 1



49 × 1



50 × 1

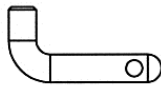

72 × 1



73 × 1



74 × 2

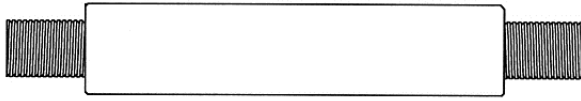

38 × 1

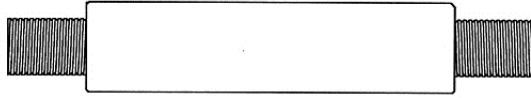

39 × 2



40 × 1

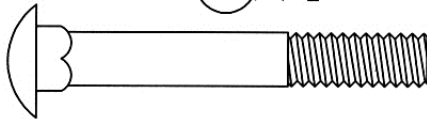

55 × 10

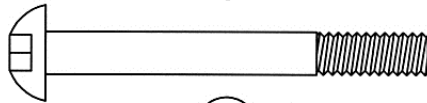

56 × 9

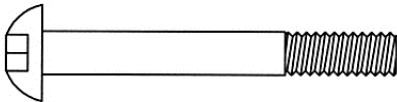

57 × 2



58 × 2

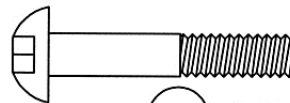

59 × 9

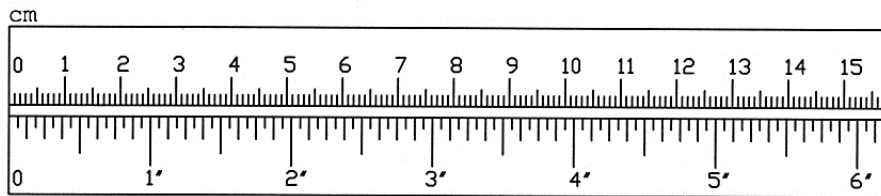

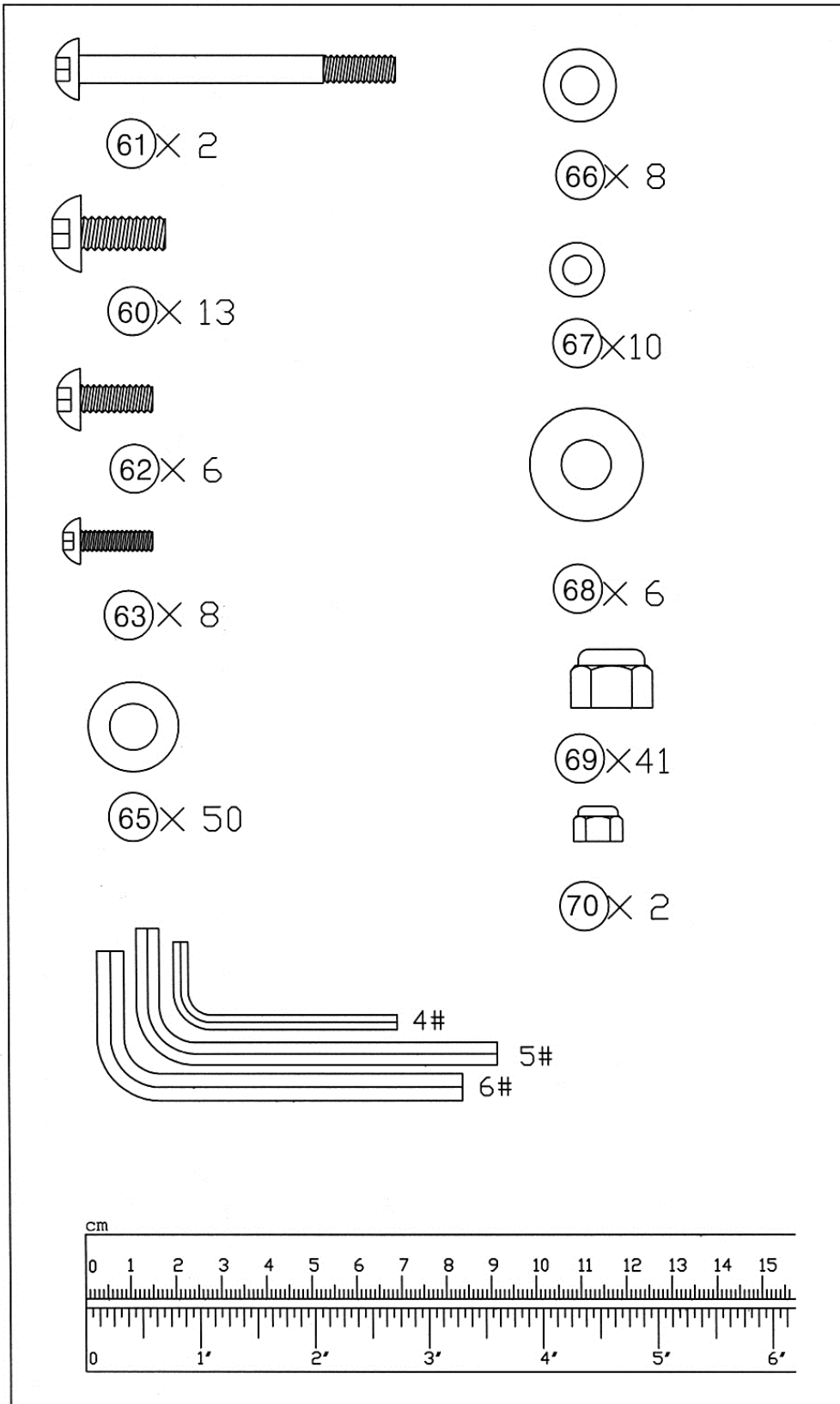

60X2

65X2



M10 x 3/4"
Ø 3/4"

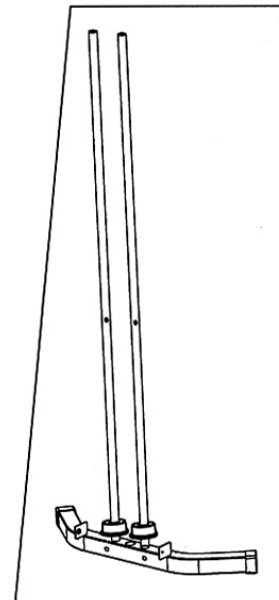
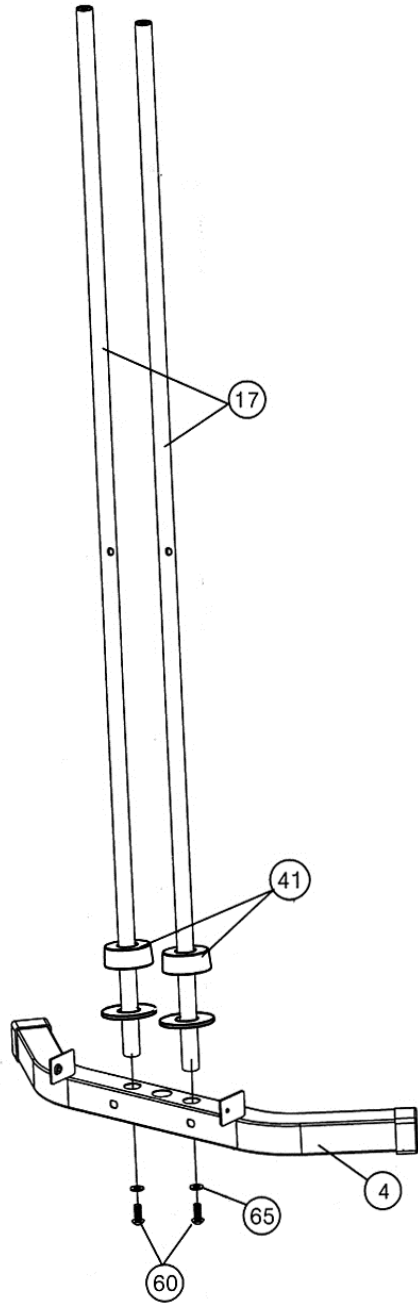
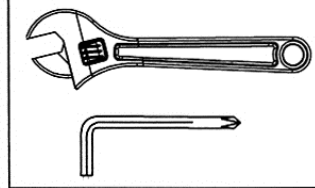

1

- 55 x 2
- 65 x 2
- 69 x 2

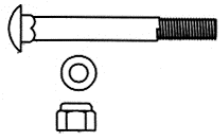

M10 x 2 3/4"
 Ø 3/4"
 M10

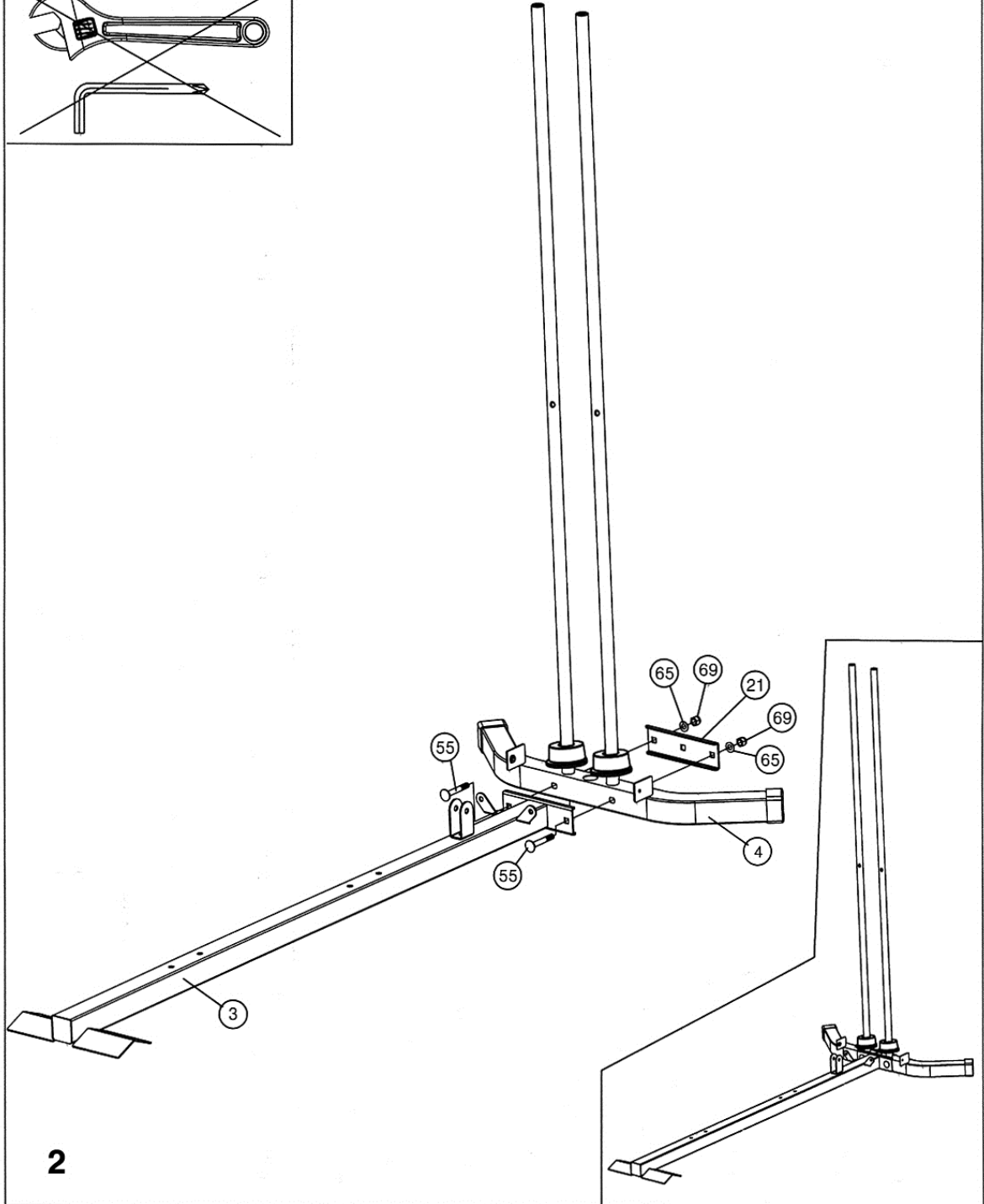
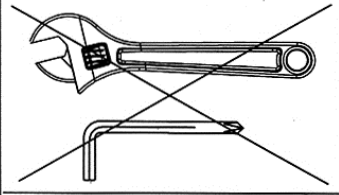

2

59x2

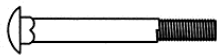

M10 x 2 3/4"

65x2



Ø 3/4"

69x2



M10

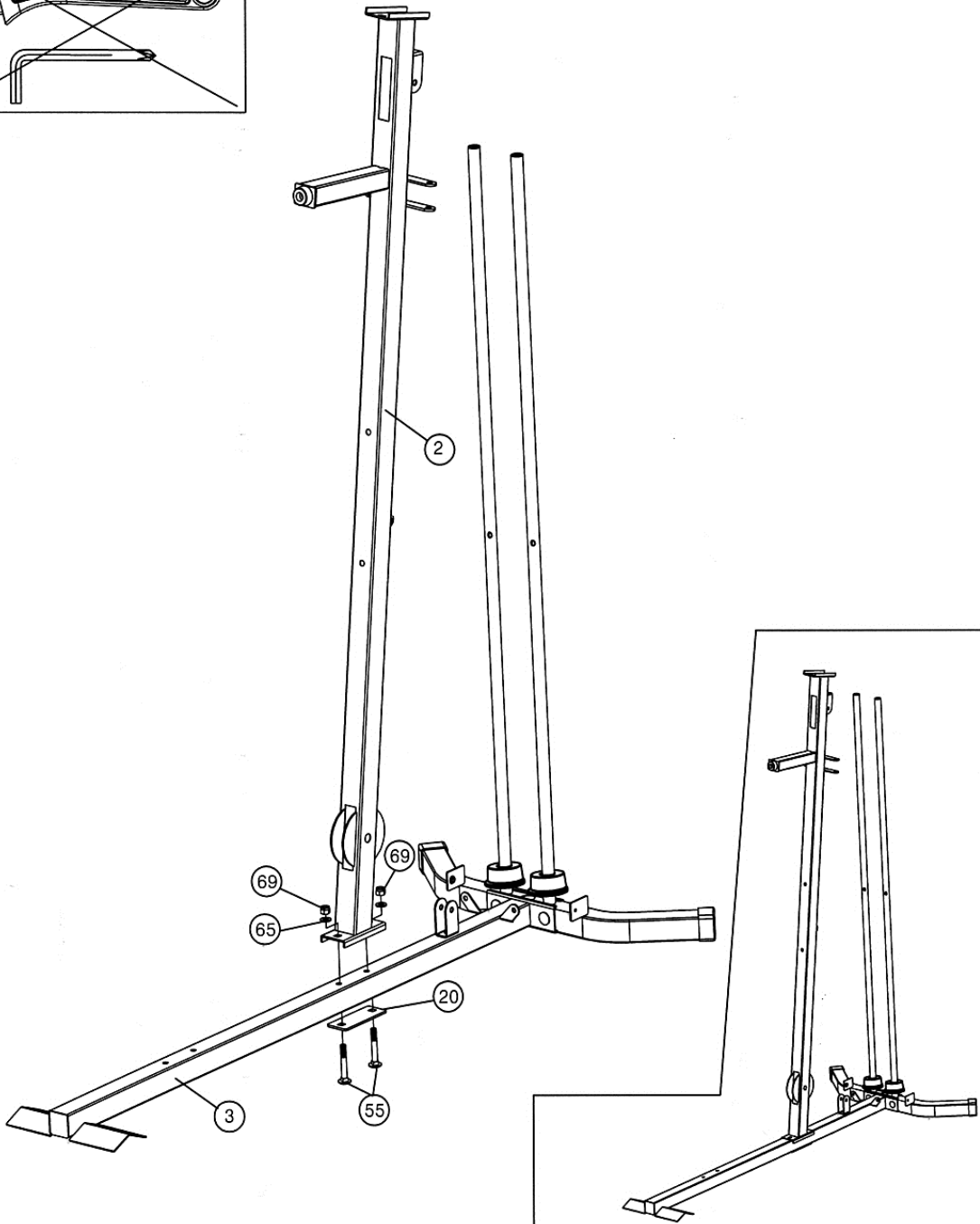
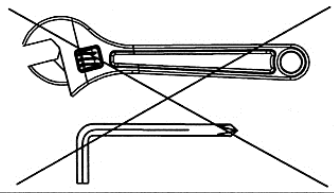

3

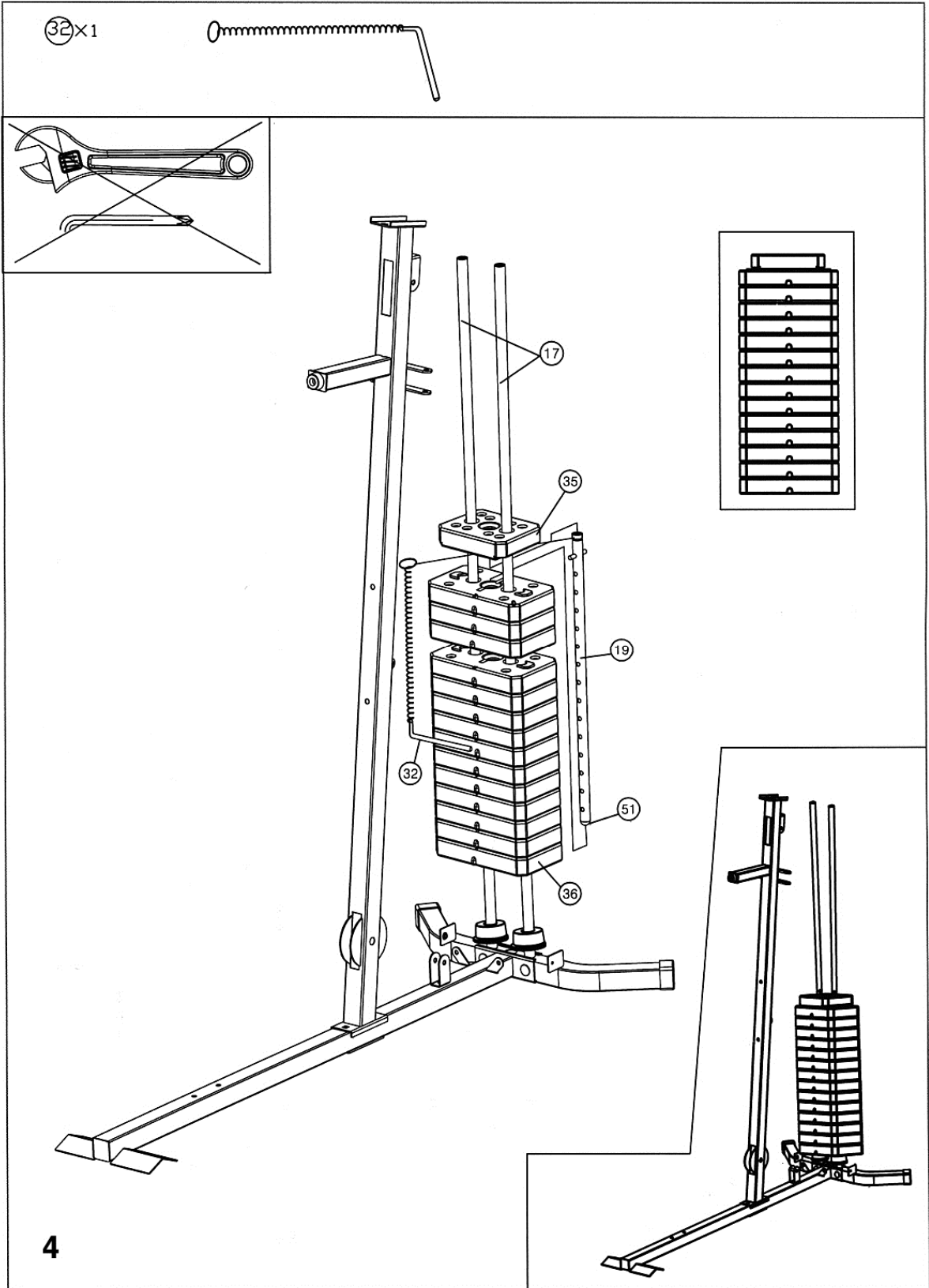

60×2



M10 × 3/4"

55×2

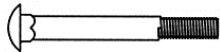

M10 × 2 3/4"

65×4



∅ 3/4"

69×2



M10

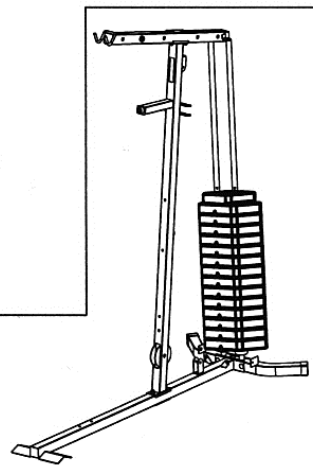
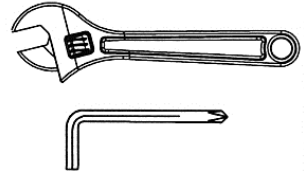
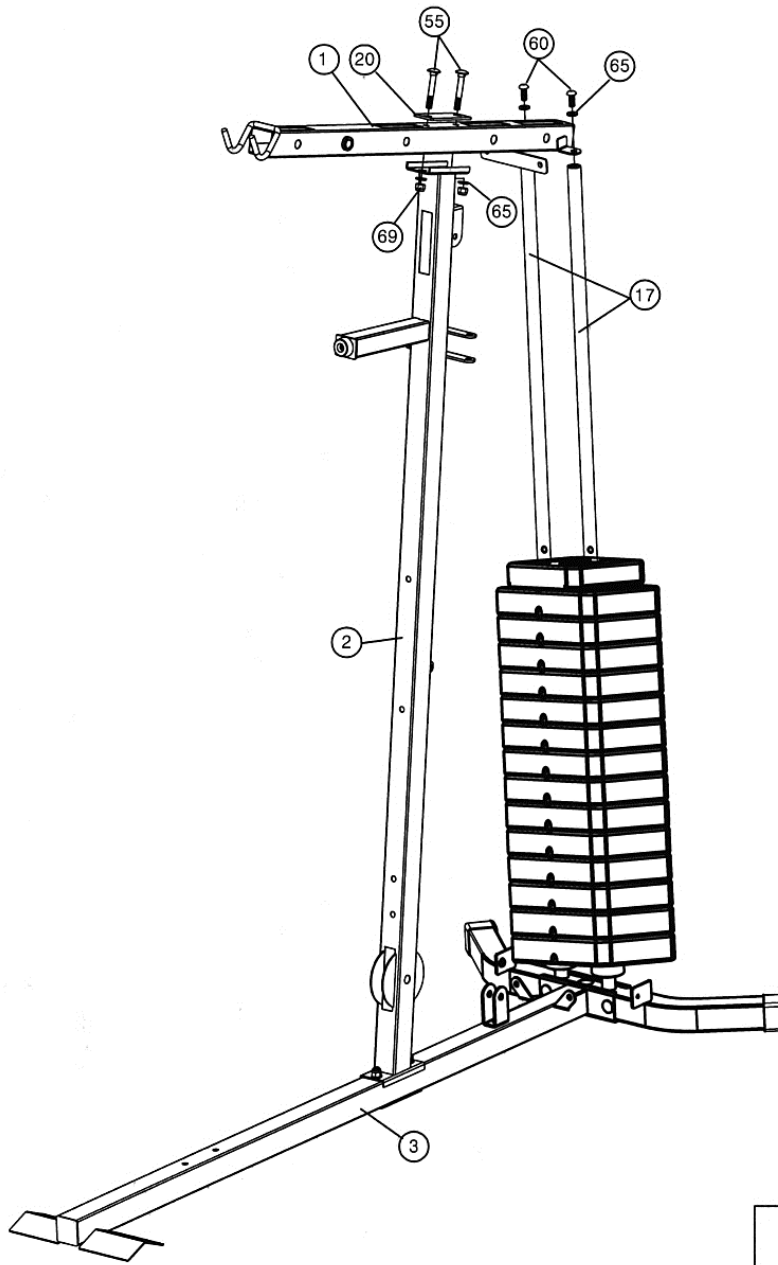

5

59x2

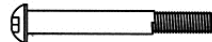

M10x70mm

59x4

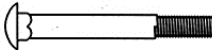

M10 x 2 3/4"

65x8



Ø 3/4"

69x6



M10

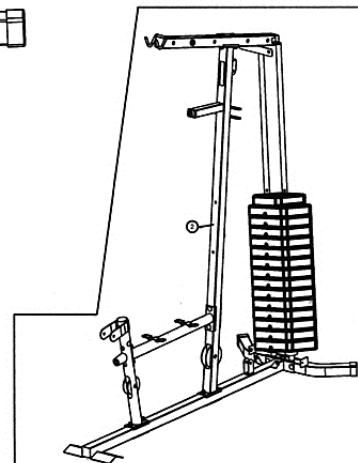
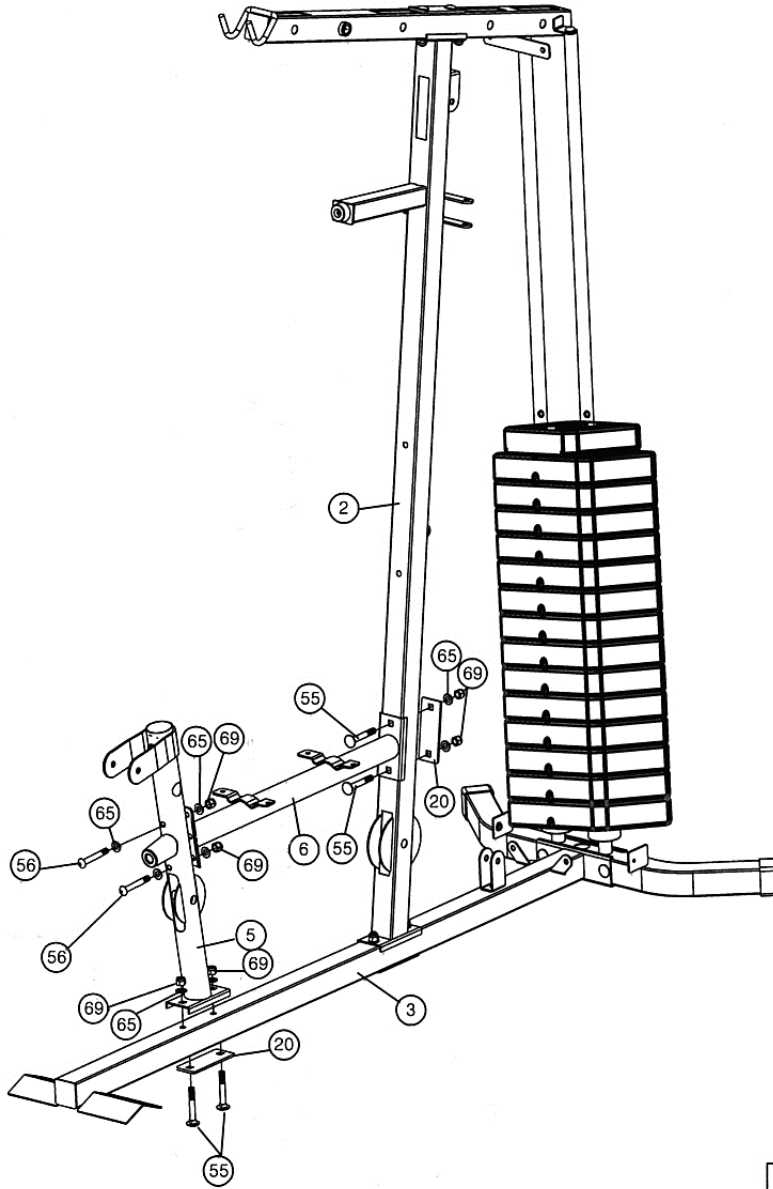
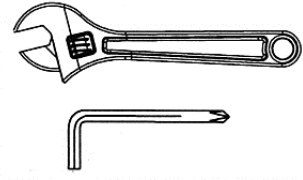

6

38 x 1



3"

68 x 2



Ø 1" x Ø 3/8"

69 x 2



M10

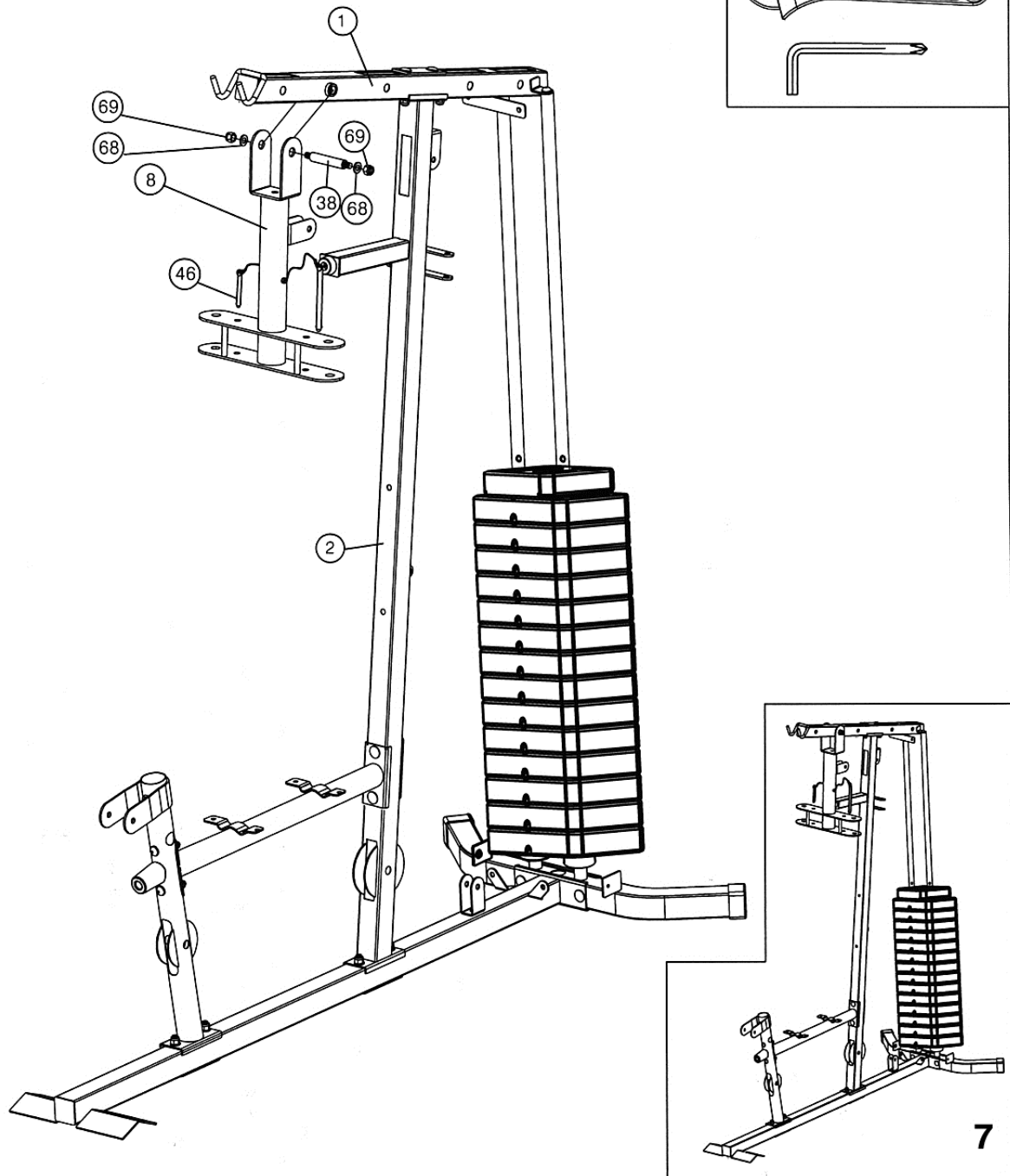

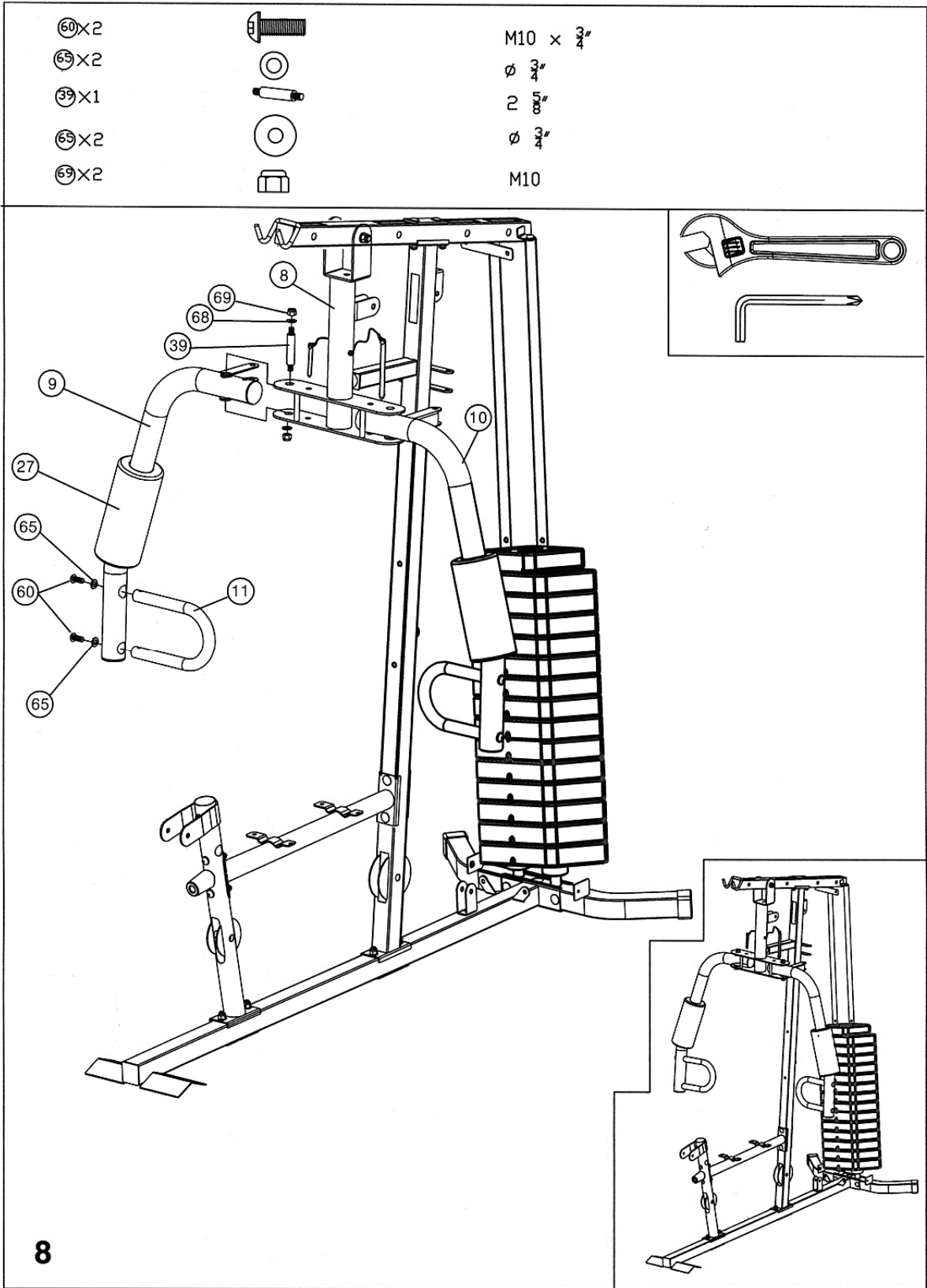

62 x 4



M8 x 5/8"

61 x 2

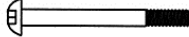

M8 x 2 3/4"

66 x 4





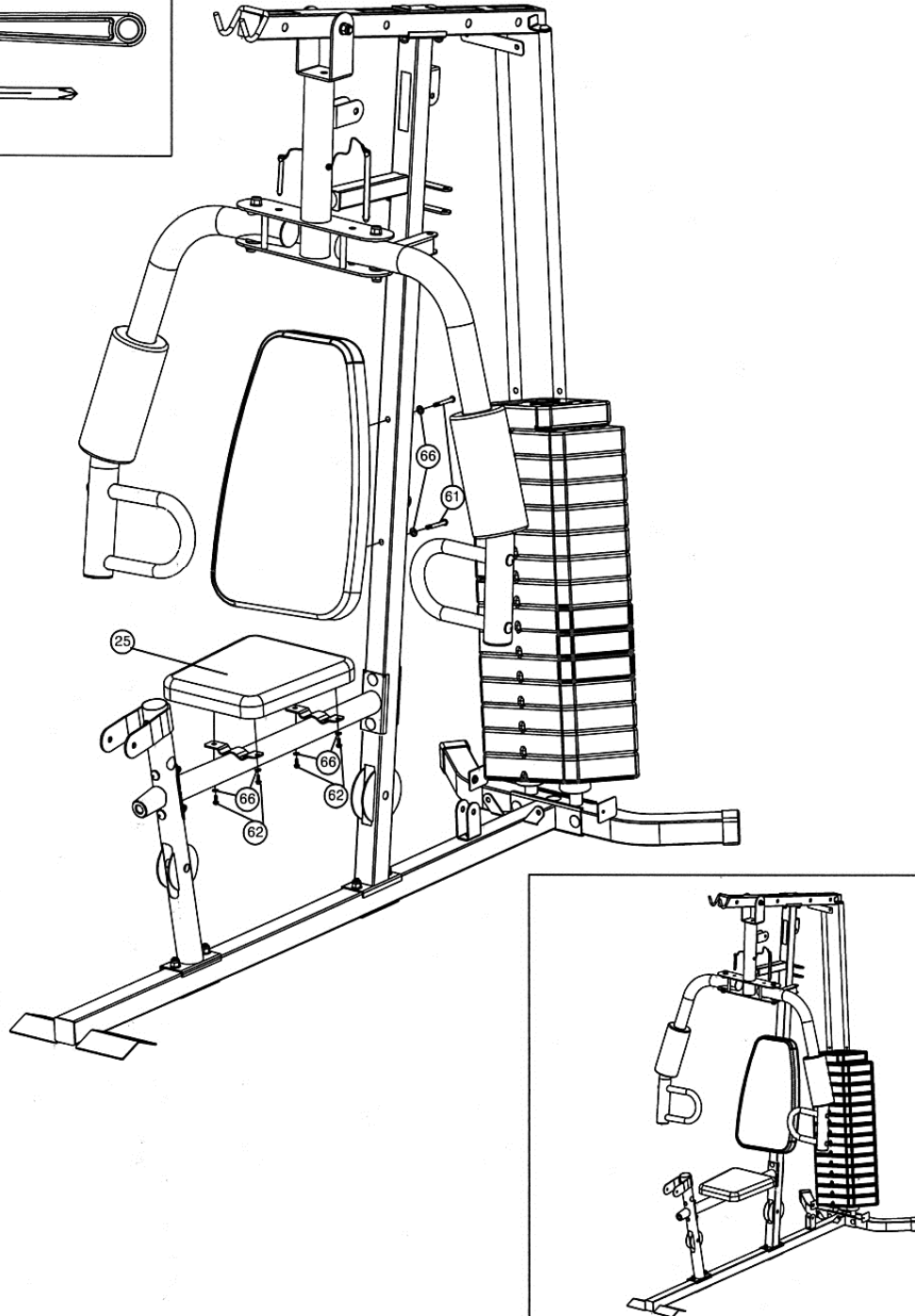
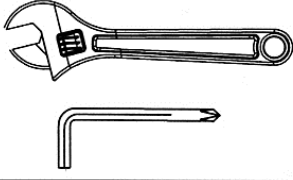

Ø 5/8"

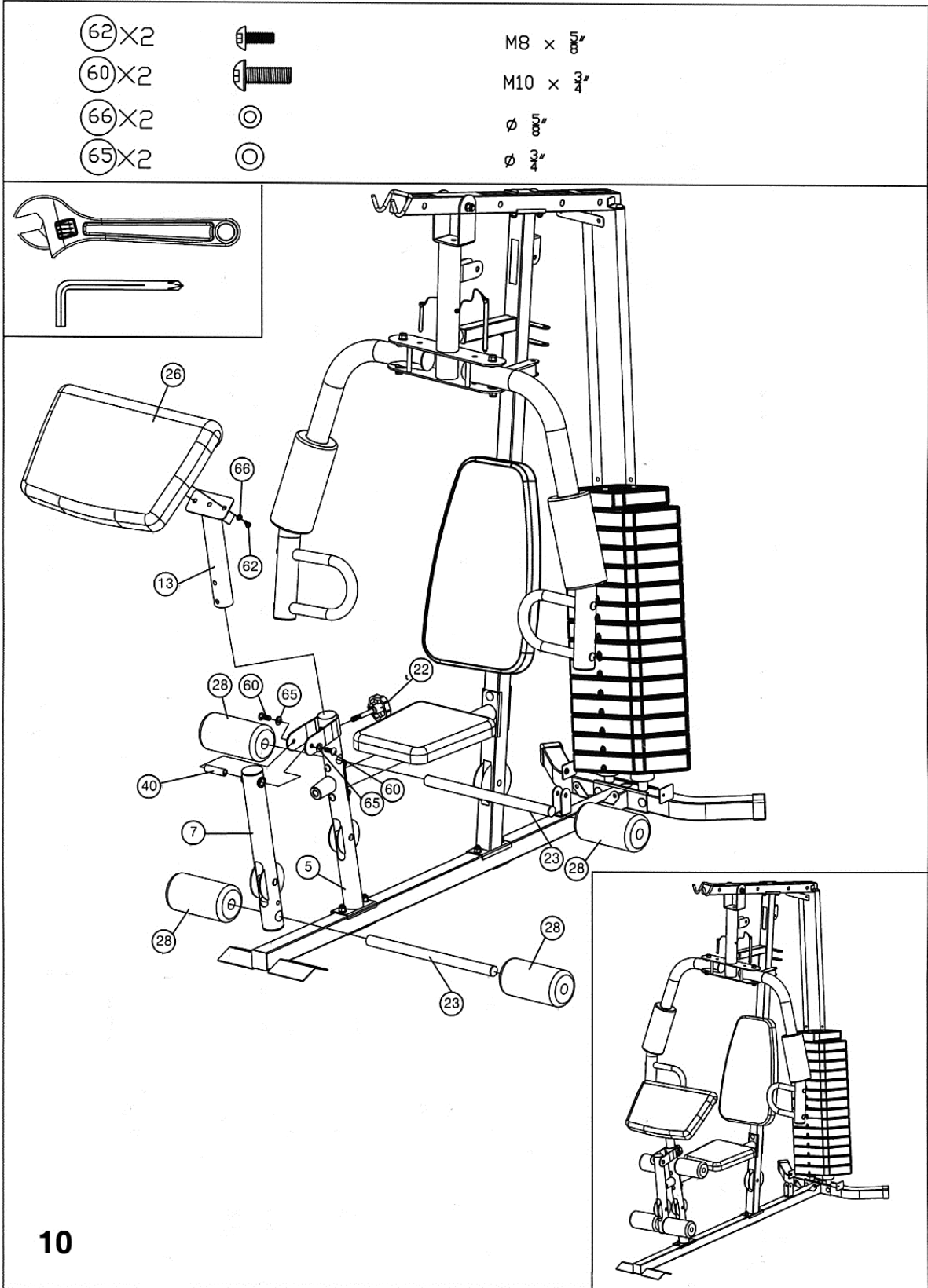

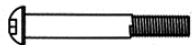
9



57x1		M10 x 2 1/2"
58x1		M10 x 2"
65x4		Ø 3/4"
69x2		M10

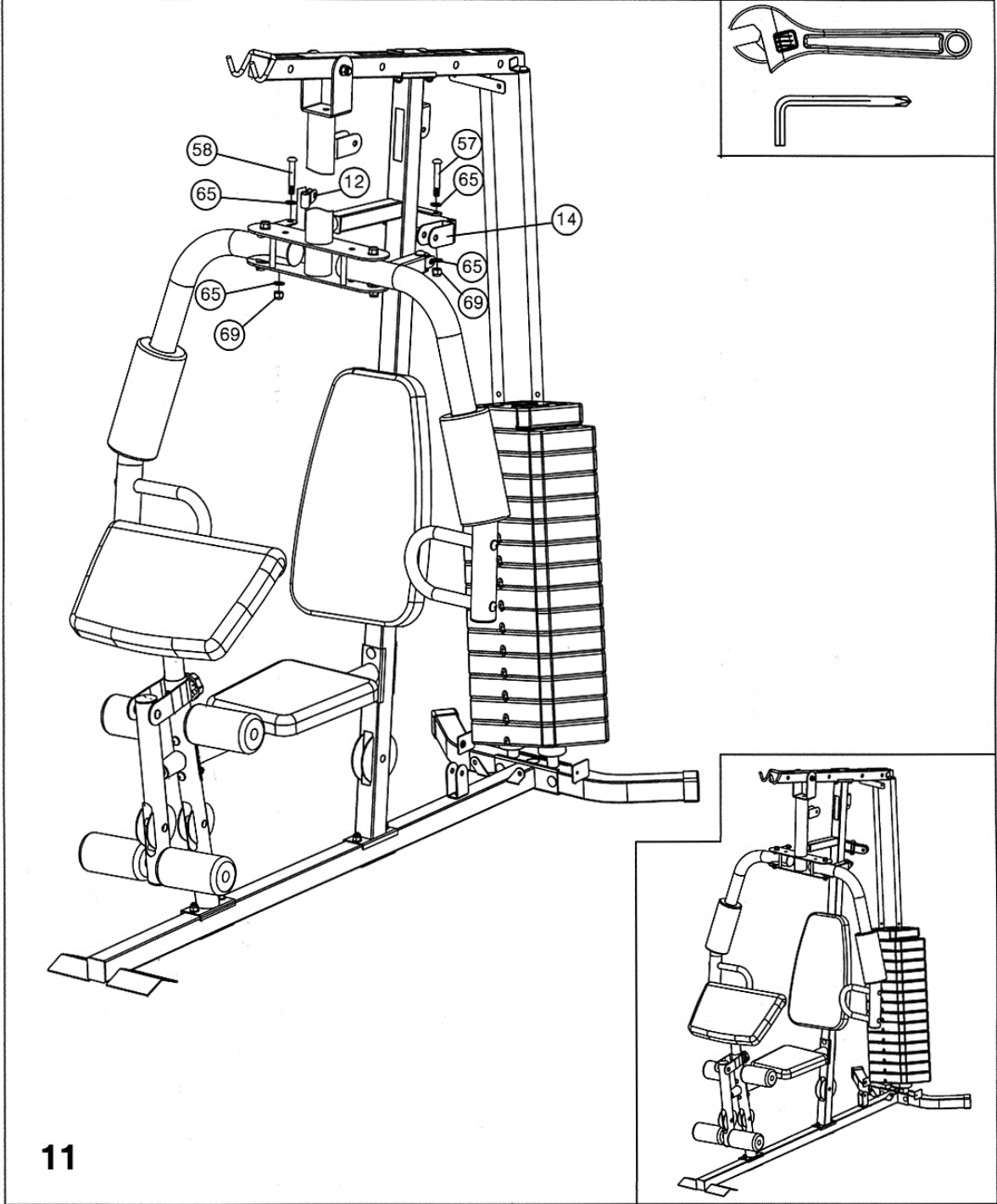

11

(63)×8



M6 × 5/8"

(67)×10



∅ 1/2"





(70)×2

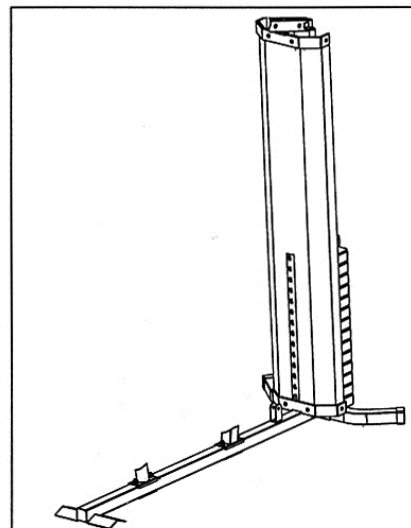
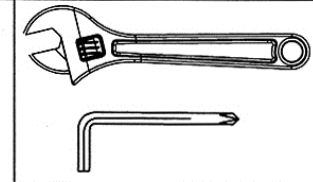
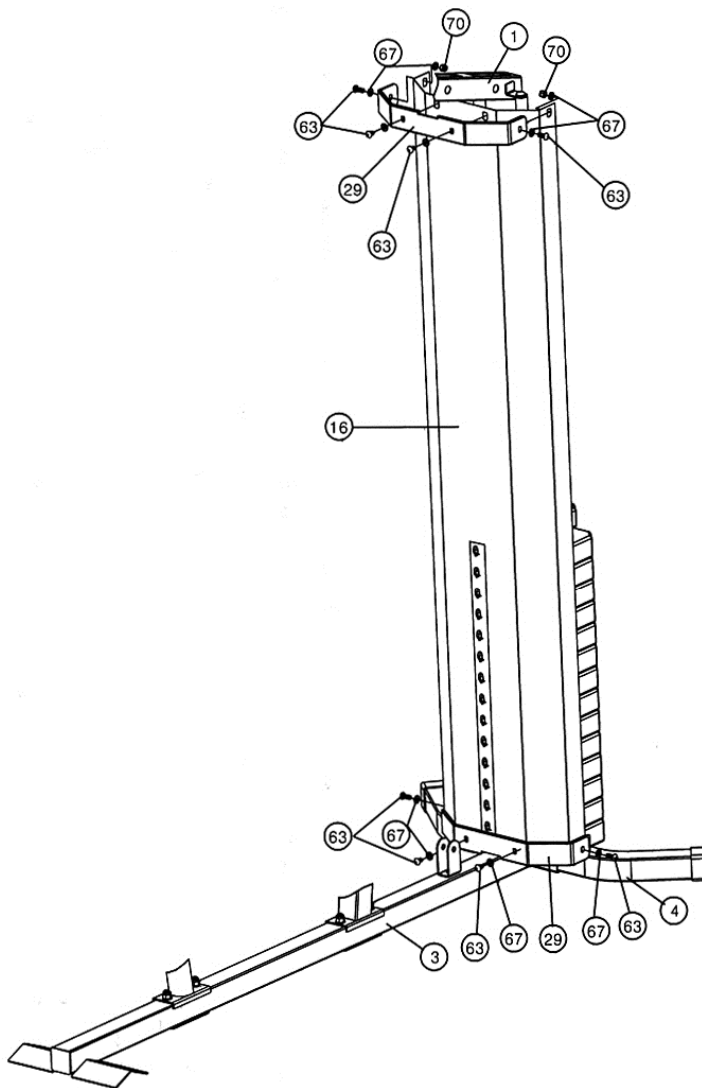

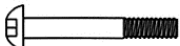

M6





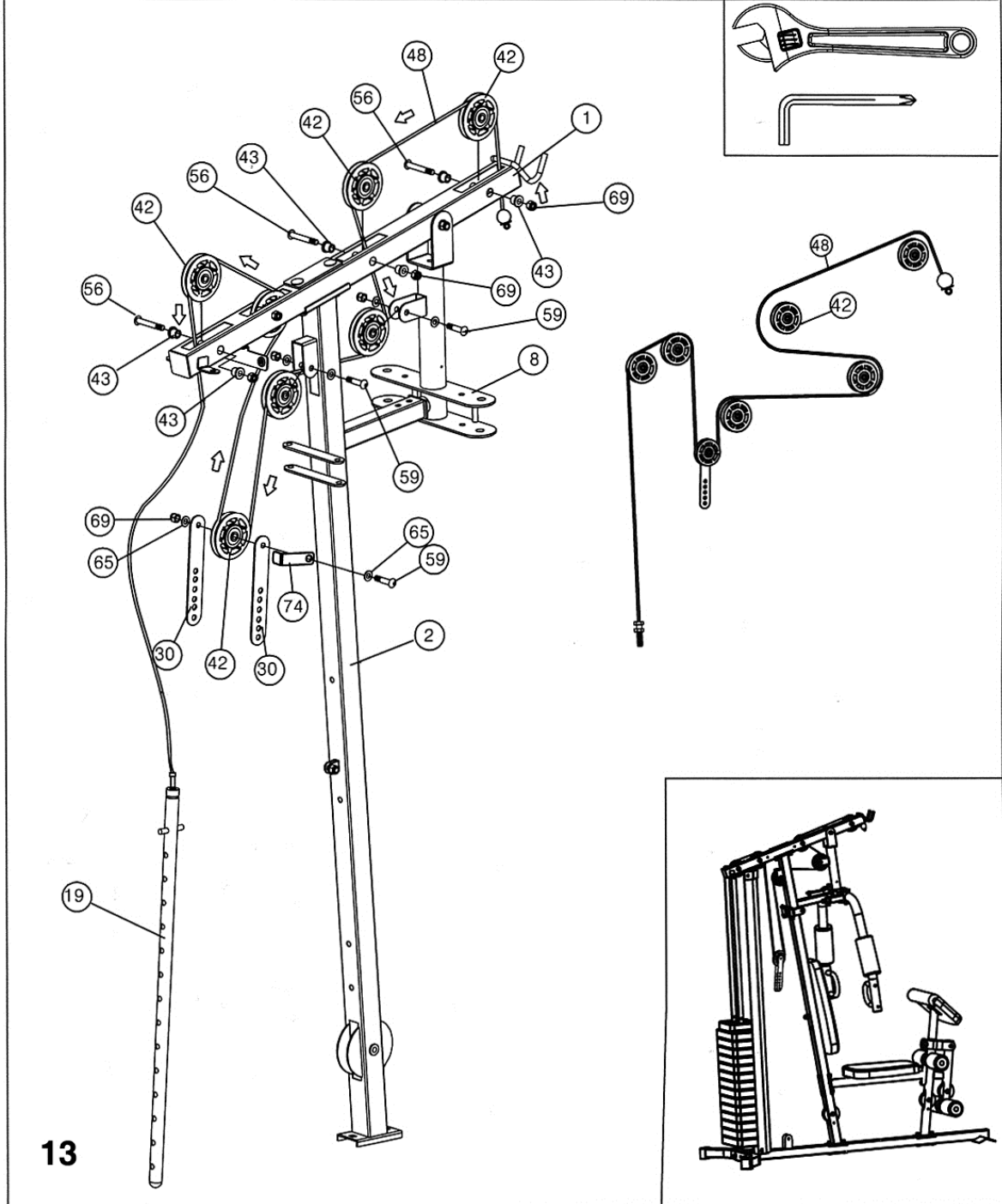

12

56×4		M10 × 2 3/4"	69×7		M10
59×3		M10 × 1 3/4"	48×1		
65×6		∅ 3/4"			

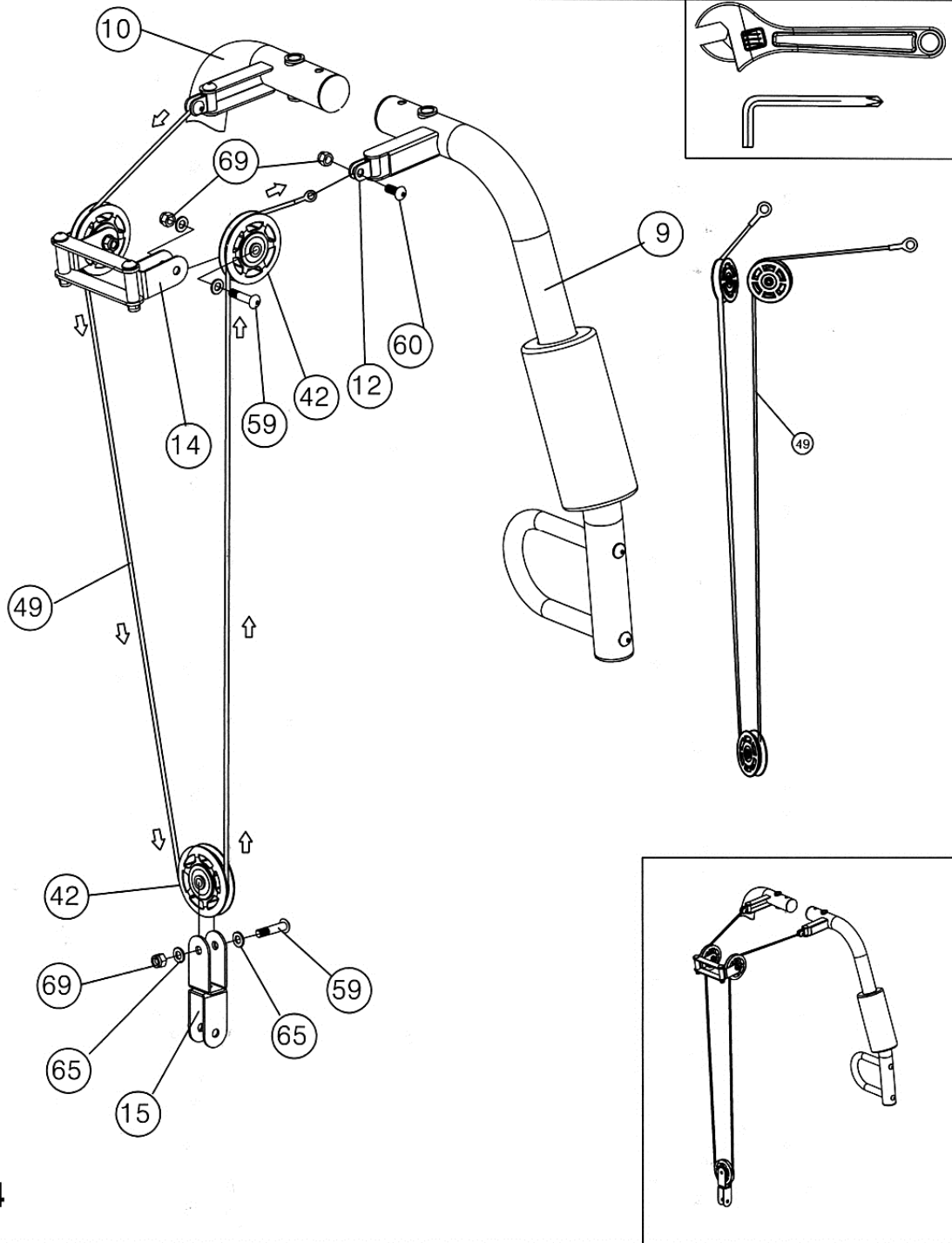

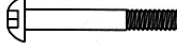
- | | | | | | |
|--------|---|------------|--------|---|--------------|
| (69)×5 |  | M10 | (59)×3 |  | M10 × 1 3/4" |
| (65)×6 |  | ∅ 3/4" | (49)×1 |  | |
| (60)×2 |  | M10 × 3/4" | | | |

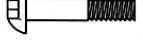

(56)×3		M10 × 2 3/4"	(69)×7		M10
(60)×1		M10 × 3/4"	(59)×3		M10 × 1 3/4"
(65)×6		∅ 3/4"	(50)×1		

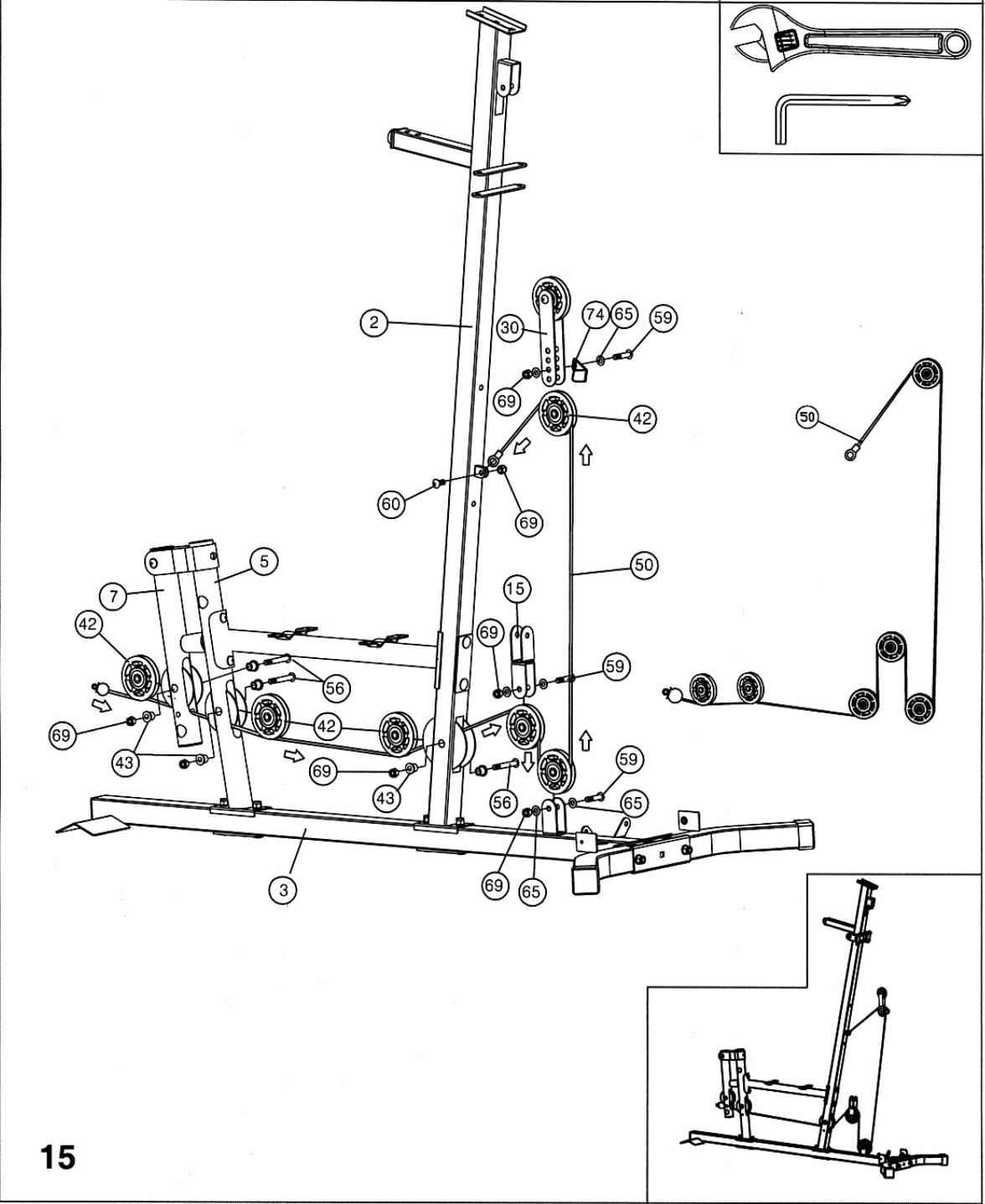

15

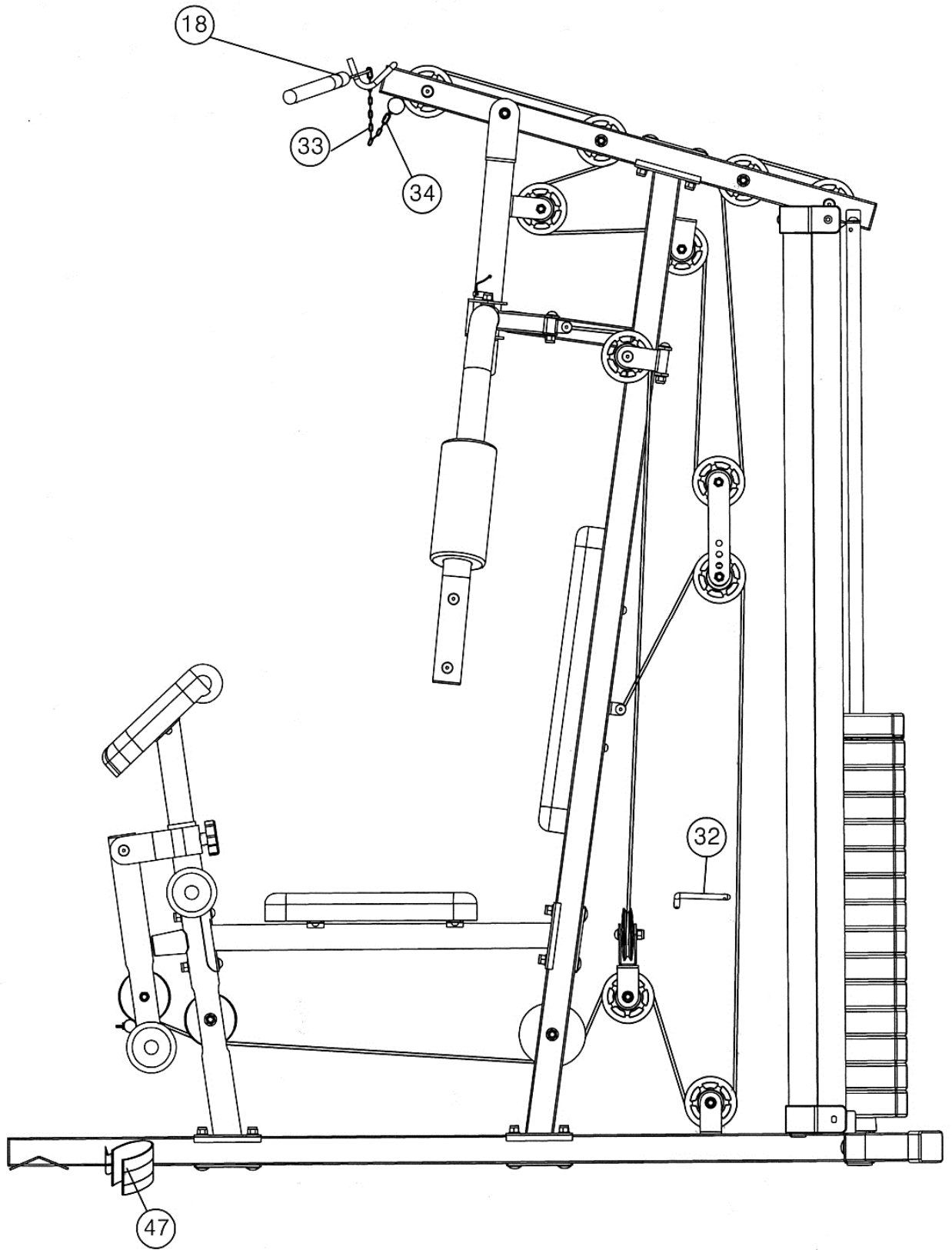

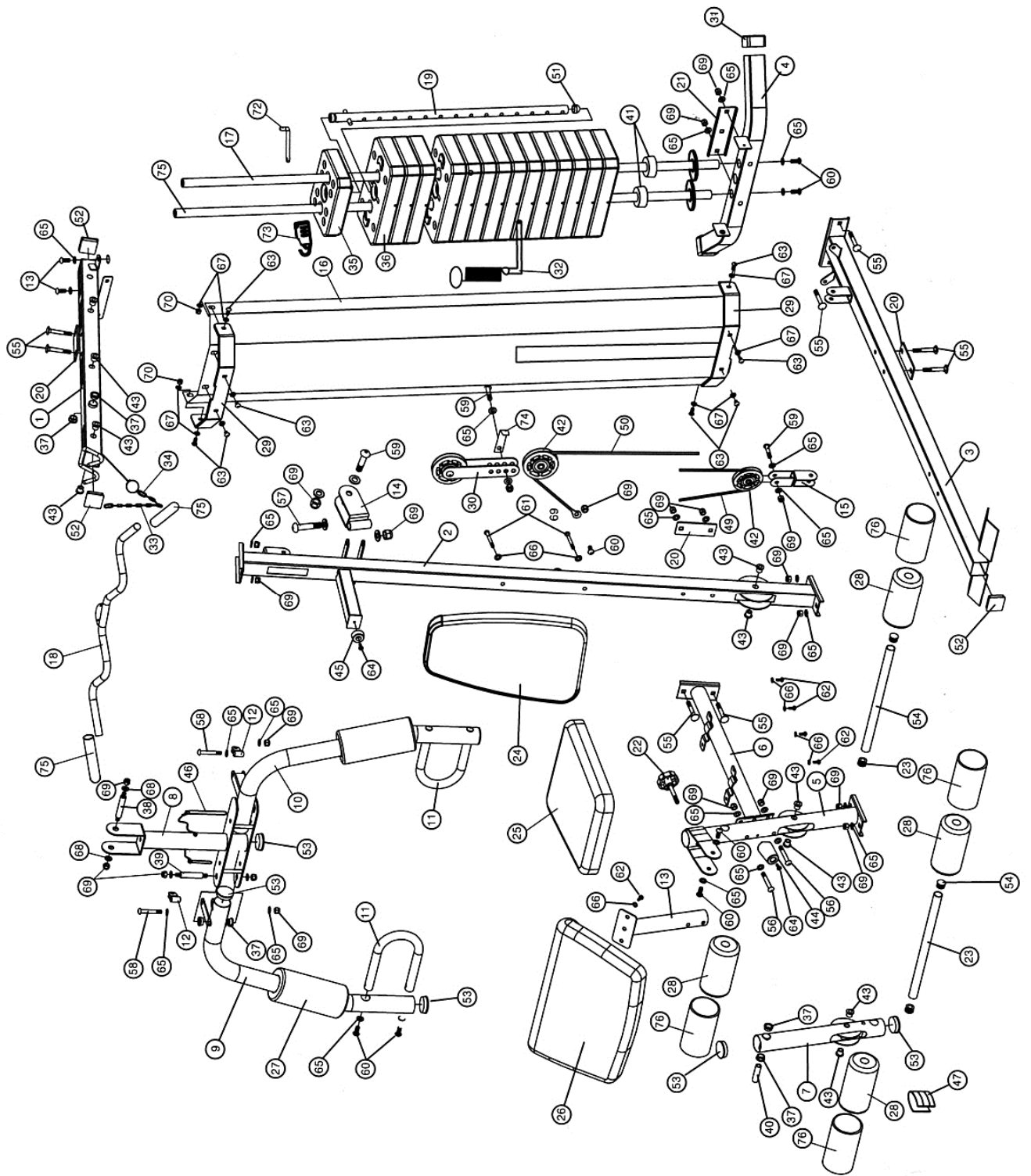

LIMITED WARRANTY

Tunturi Fitness warrants this product to be free from defects in workmanship and material, under normal use and service conditions, for a period of two years on the frame and one year on all other parts and components from the date of purchase. This warranty extends only to the original purchaser. Tunturi Fitness's obligation under this Warranty is limited to replacing damaged or faulty parts at Tunturi Fitness's option.

All returns must be pre-authorized by Tunturi Fitness. This warranty does not extend to any product or damage to a product caused by or attributable to freight damage, abuse, misuse, improper or abnormal usage, purchasers own repairs or for products used for commercial or rental purposes. No other warranty beyond that specifically set forth above is authorized by Tunturi Fitness.

Tunturi Fitness is not responsible or liable for indirect, special or consequential damages arising out of or in connection with the use or performance of the product or other damages with respect to any economic loss, loss of property, loss of revenues or profits, loss of enjoyments or use, costs of removal, installation or other consequential damages or whatsoever natures.

The warranty extended hereunder is in lieu of any and all other warranties and any implied warranties of merchantability or fitness for a particular purpose is limited in its scope and duration to the terms set forth herein.

Your statutory rights are not affected.

ORDERING REPLACEMENT PARTS

Replacement parts can be ordered by contacting our Customer Support Department, Monday to Friday, 9am – 5pm GMT +1 hour:

E mail: service.international@tunturi-fitness.com

When ordering replacement parts, please give the following information,

- 1. Model**
- 2. Description of Parts**
- 3. Part Number**
- 4. Date of Purchase**