

opti AIR 2 IN 1

Assembly & User Instructions - Please keep for future reference

6164933

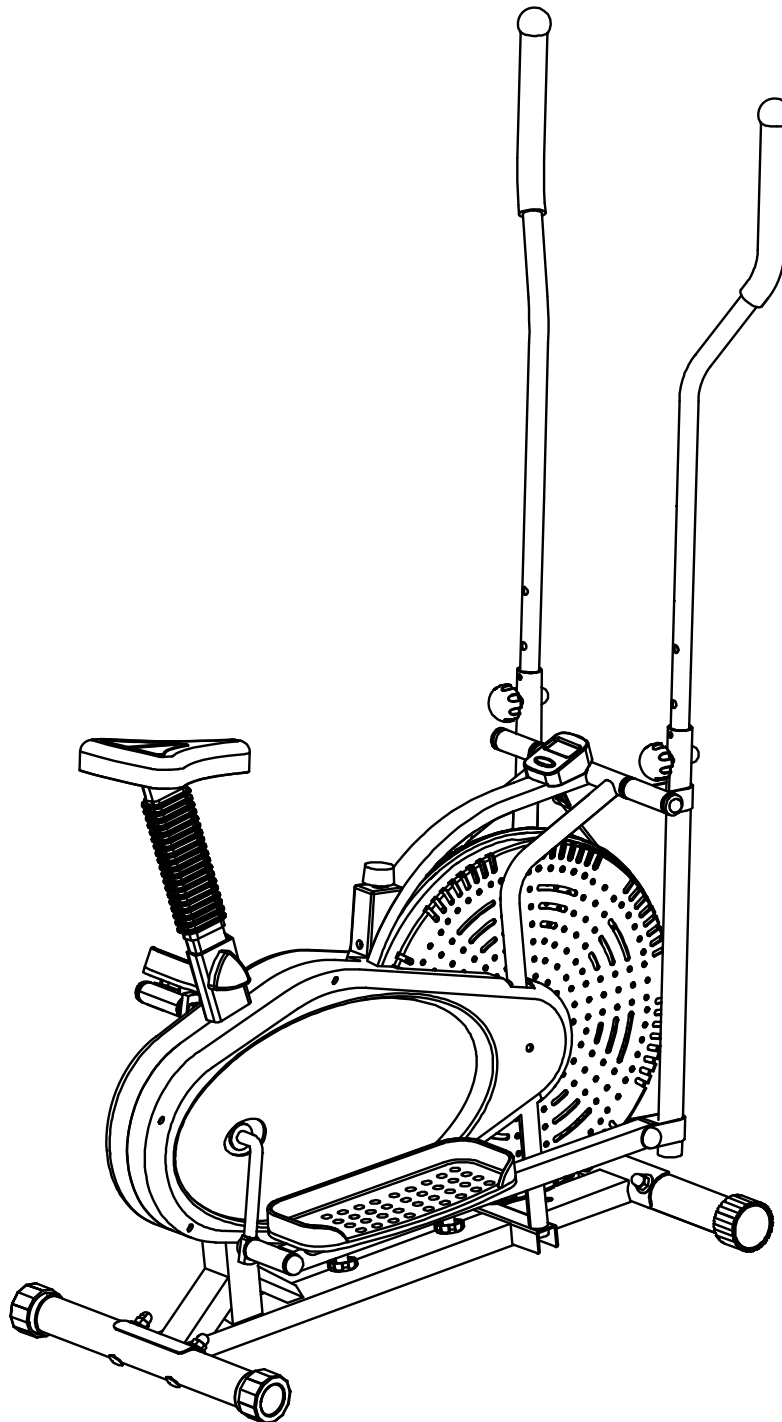

Important – Please read these instructions fully before assembly or using

These instructions contain important information which will help you get the best from your equipment and ensure safe and correct assembly, use and maintenance.

If you need help or have damaged or missing parts, call the **Customer Helpline: 0345 600 1714**
www.argos-support.co.uk

Contents

| | |
|---------------------------------------|--------------|
| Safety Information | 2 |
| Components - Parts | 3 |
| Components - Fixings | 4 |
| Assembly Instructions | 5-8 |
| Computer Operation | 9 |
| Exercising Information | 10-15 |
| Before starting to exercise | 12 |
| Muscle chart | 13 |
| Warming up and cooling down exercises | 14-15 |
| Care and Maintenance | 16 |
| Disposal information | 16 |
| Explodes Parts Diagram | 17 |
| Explodes Parts Diagram List | 18 |
| Guarantee | Back |

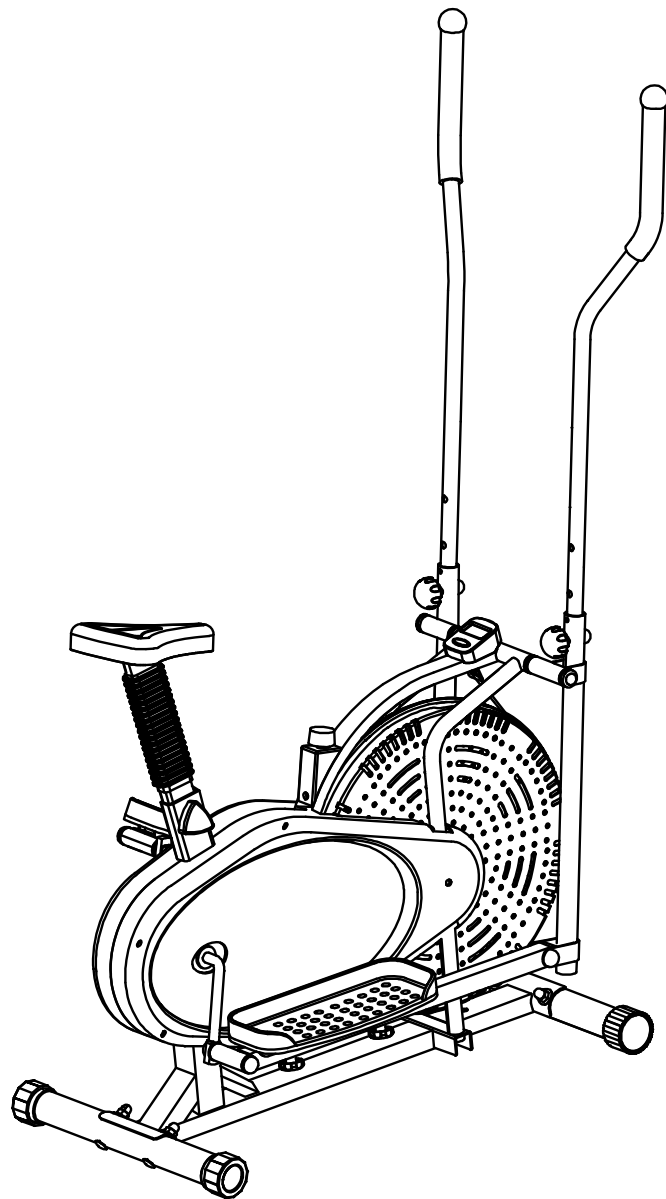



Safety Information



Important – Please read fully before assembly or using

To reduce the risk of serious injury, read the entire manual before you assemble or operate the Magnetic cycle. In particular, note the following safety precautions:

Assembly

- Check you have all the components and tools listed on pages 3 and 4, bearing in mind that, for ease of assembly, some components are pre-assembled.
- Keep children and animals away from the work area, small parts could choke if swallowed.
- Make sure you have enough space to layout the parts before starting.
- The free standing equipment shall be installed on a stable and levelled base.
- Position the equipment on a clear, level surface.
- Dispose of all packaging carefully and responsibly.

Using

- This product is intended for domestic use only.
- Free space required for safe operation.
- Before using the equipment to exercise, always do stretching exercises to properly warm up.
- If the user experiences dizziness, nausea, chest pain, or other abnormal symptoms **stop the workout and seek immediate medical attention.**
- Only one person at a time should use the equipment.
- Keep hands away from all moving parts. Keep
- Keep unsupervised children away from the equipment.
- Always wear appropriate workout clothing when exercising. **Do not** wear loose or baggy clothing, since it may get caught in the equipment. Wear athletic shoes to protect your feet while exercising.
- The braking system is speed-independent.

- **Do not** place any sharp objects around the bike.
- Disabled persons should not use the equipment without a qualified person or doctor in attendance.
- The maximum user body mass is 100 kg.
- **Mounting:** When mounting the machine it is recommended that the pedal closest to you is in its lowest position. If you are standing to the left side of the machine, when facing the console, place your left foot on the pedal closest to you and then swing your right leg over to the right pedal. Use the stationary handlebar to stabilize yourself.
- **Dismounting:** Bring the machine to a stop. It is recommended to put the pedal in its lowest position on the side of the unit you will be dismounting. If dismounting the machine on the left side, when facing the console, step off with the right leg first followed by the left leg. Use the stationary handlebar for stabilization.

- This product conforms to: (BS EN ISO 20957-1 &EN957-9)
- Class (H) - Home Use - Class (C).
- This exercise product has been designed and manufactured to comply with the latest (BS EN ISO 20957-1 &EN957-9) British and European Safety Standards.

Battery safety

- **Warning:** Incorrect installation of batteries may cause battery leakage and corrosion, resulting in damage to the computer.
- **Do not** mix old and new batteries, or batteries of different types.
- **Do not** dispose of batteries in a fire.
- **Do not** dispose of batteries with normal household waste, take to a local recycling centre.



Warning: Before beginning any exercise program, consult your Doctor. This is especially important for persons over the age of 35 or persons with pre-existing health problems. This equipment is not suitable for therapeutic purposes. Heart rate monitoring systems may be inaccurate. Injuries to health may result from incorrect or excessive training. Over exercise may result in serious injury or death. If you feel faint stop exercising immediately". You **MUST** read all instructions before using any fitness equipment. Argos and its associates assumes no responsibility for personal injury or property damage sustained by or through the use of this product.

Components - Parts

Please check you have all the parts listed below

Note: Some of the smaller components may be pre-fitted to larger components. Please check carefully before contacting Argos regarding any missing components.

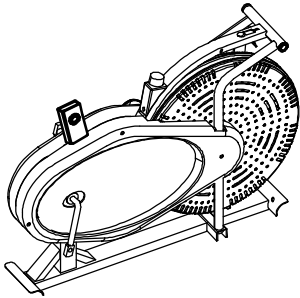

1.Main Frame x1

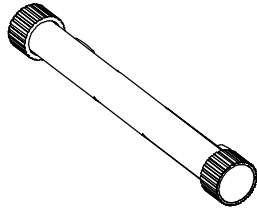

2.Front bottom tube x1

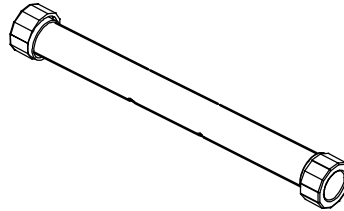

3.Back bottom tube x1

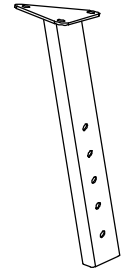

69.Seat Tube x1

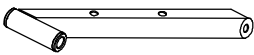

6L.pedal tube x1

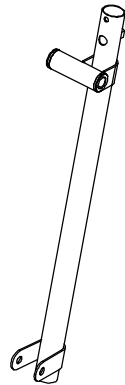

4R.couple bar x1

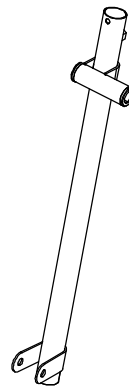

4L.couple bar x1



7L.handle bar x1

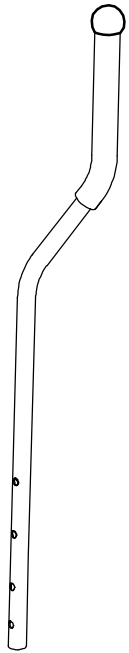

7R.handle bar x1

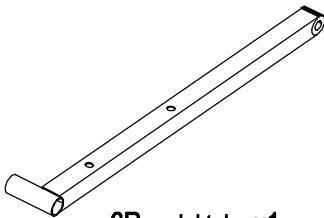

6R.pedal tube x1

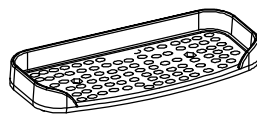

11R.Pedal x1

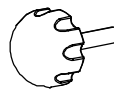

17.Knob bolt x2



50.Computer x1



76.Knob x4



11L.Pedal x1

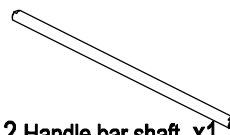

12.Handle bar shaft x1



72.Saddle x1



62.S13 Plastic cap x2



59.S16 Plastic cap x4



60.S18 Plastic cap x2



74.Seat Post Sleeve x1

















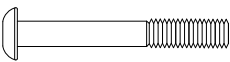

73.Triangle Knob x1

Components - Fixings

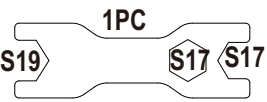

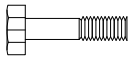
Please check you have all the fixings listed below

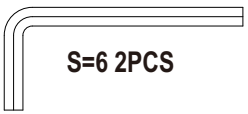
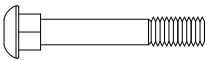
Note: Some of the fixings are pre-fitted to the larger components. Please check carefully before contacting Argos regarding any missing fixings.

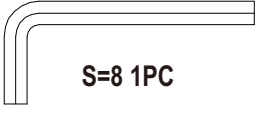
| | | | |
|---|---|---|--|
| <p>46 </p> <p>D10 Arc Washer x4</p> | <p>47 </p> <p>M10 Acorn Nut x4</p> | <p>63 </p> <p>D10 Spring Washer x4</p> | <p>70 </p> <p>M8 Nylon Nut x3</p> |
| <p>41L/R </p> <p>Φ16 x 111.8 Pedal hinge bolt(L/R) x1</p> | <p>64 </p> <p>φ28xφ16x0.3 Wave washer x2</p> | <p>51 </p> <p>Ø13*B2 Spring Washer x2</p> | <p>71 </p> <p>D8 Washer x3</p> |
| <p>57 </p> <p>M10X18 Boltx2</p> | <p>52 </p> <p>Φ10.5 Spring Washer x2</p> | <p>56 </p> <p>Φ28×Φ16.2×14×B5 D shape washer x2</p> | <p>1PC </p> <p>S19 S17 S17</p> |
| <p>65 </p> <p>D10 Flat Washer x4</p> | <p>44 </p> <p>M10*45 Hex Bolt x4</p> | <p>45 </p> <p>M10 Nylon Nut x2</p> | <p>S=6 2PCS </p> |
| <p>61 </p> <p>M10 x L63 Carriage bolt x4</p> | <p>48L/R </p> <p>B0.5X20 Nylon Nut (L/R) X1</p> | <p>10 </p> <p>Φ16×1×Φ28 Washer x1</p> | <p>S=8 1PC </p> |

Ruler - Use this ruler to help correctly identify the hardware

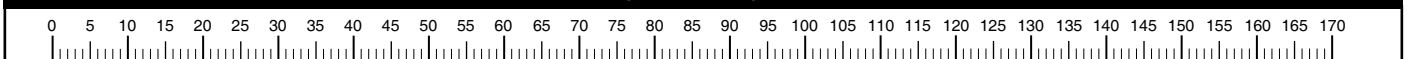

Assembly Instructions

Prior to assembly of this product, remove all components from the package and verify all the listed parts are supplied. Once certain, begin with the first assembly step.

Step 1

Total mass of the product is 25 kg. Total surface area (e.g. foot print) of equipment is 92 cm× 63 cm.

Install the Front bottom tube (2) and Back bottom tube (3) to the Main frame (1) with Carriage bolts (61), Arc washers (46) and Spring Washer (63) Acorn nuts (47).

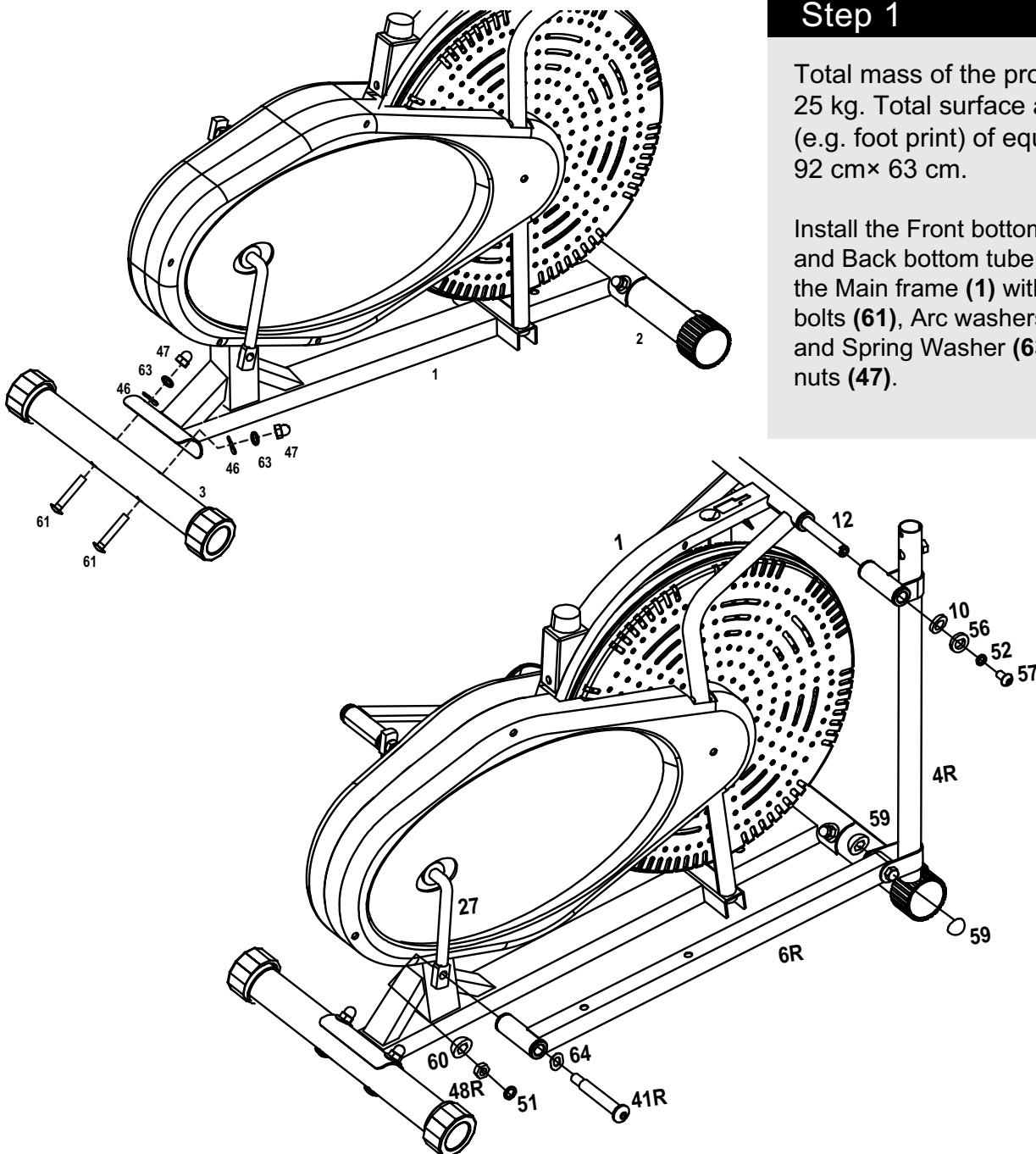

Step 2

A: Insert the Handle bar shaft (12) through the Coupler bar (4L/R) to the Main frame (1) at the same time, then fix with Bolt (57), Spring Washer (52), D sharp washer (56), Washer (10).

B: Insert the Pedal hinge bolt (41L/R) through the Pedal tubing (6L/R) to the Crank (27) and fix with Wave washer (64), Spring Washer (51), Nylon Nut (48L/R). Finally cover with plastic cap (59)&(60).

Note: Both Pedals Hinge Bolts are labeled L FOR LEFT and R FOR RIGHT. To tighten turn the left bolt COUNTERCLOCK- WISE and the right bolt CLOCKWISE. Move the Crank to a proper angle for easily tightening the Bolts.

Assembly Instructions

Step 3

Attach the Pedals (11L/R) to the Pedal tubes (6L/R) with Hex bolt (44), Flat Washer (65) and Knob (76).

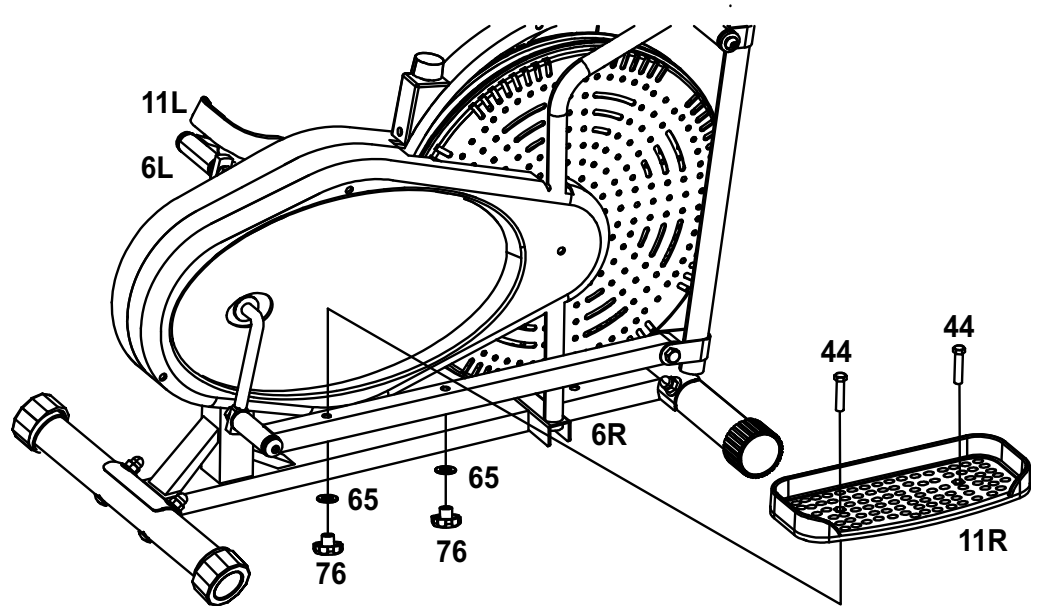

Step 4

Insert the Handle bar (7L/R) to the coupler bar (4L/R), select a height setting that is comfortable to the user, and make sure both handle bars are set at the same height. Lock each handle bar in a place with Knob bolts (17). Then cover with plastic cap (62).

Note:

You can easily switch your Handlebars (7L/R) between the dual-action mode and the fixed mode during your workout.

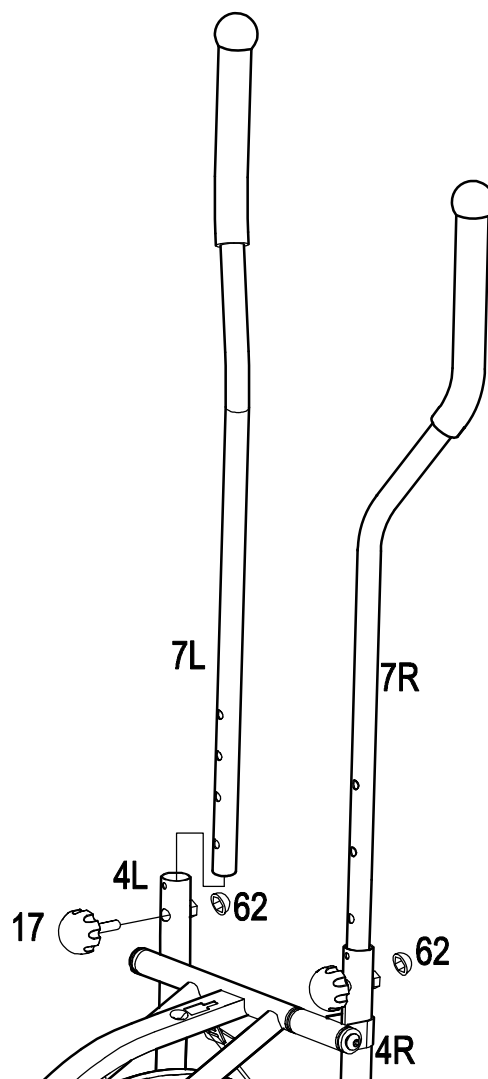

Step 5

Attach the Saddle (72) to the Seat Tube (69) with Nylon Nuts (70) and Washers (71) provided; Slide the Seat post Sleeve (74) into the Seat Tube (69),

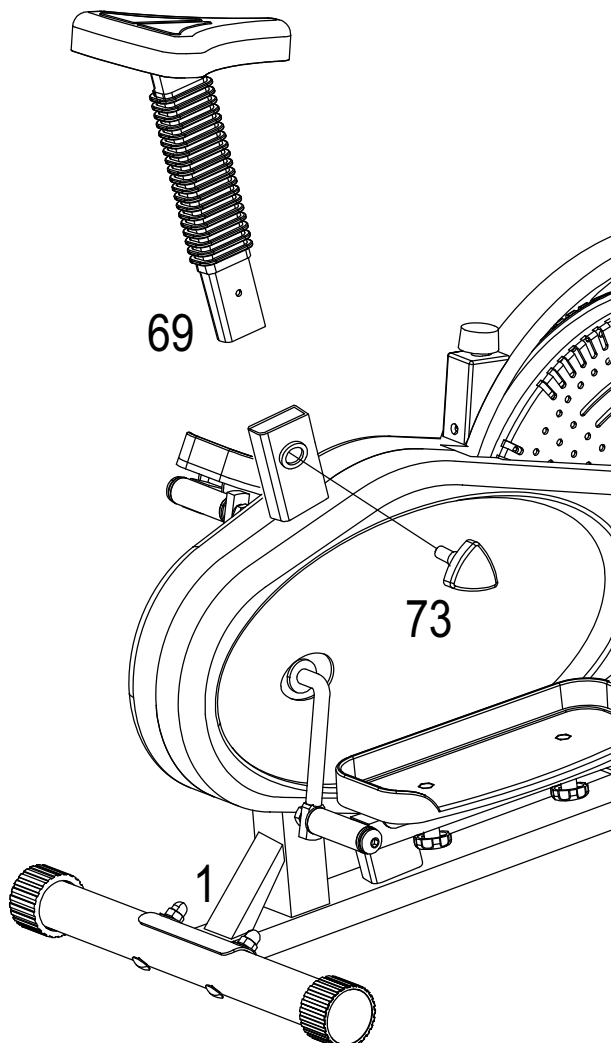
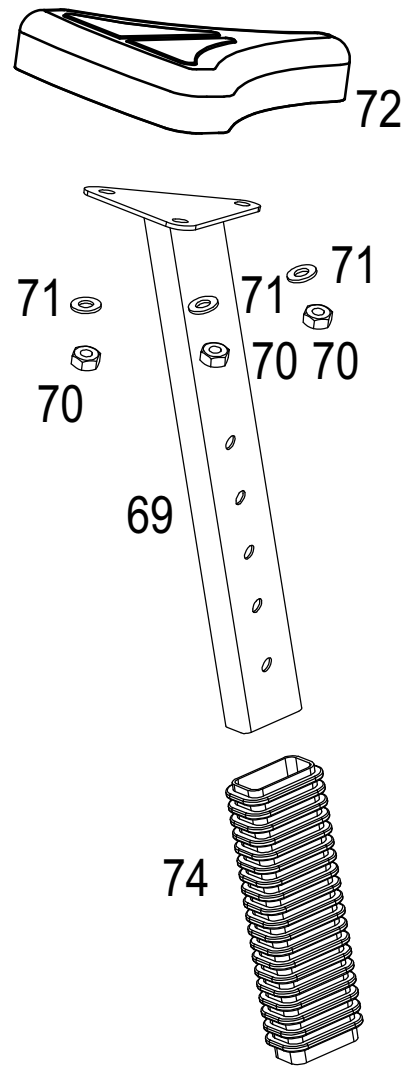

Step 6:

Insert the Seat Tube (69) with Saddle into the Main frame (1) and lock at desired height with Triangle knob (73).

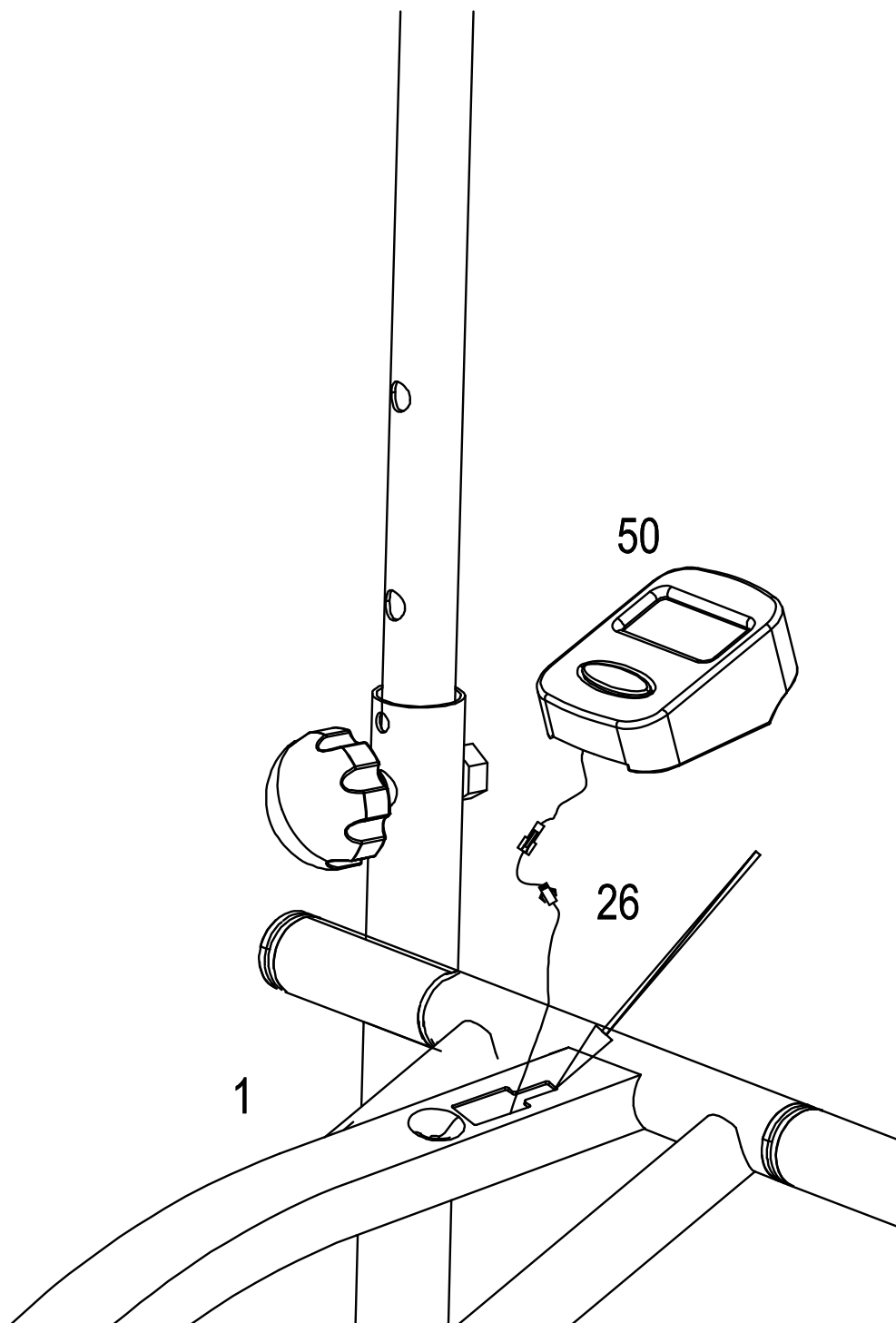

Step 7:

Connect the computer (50) wire with sensor (26) wire, after that insert the Computer (50) to the Main frame (1).

Tension adjustment

The assembly of your Elliptical Trainer is now complete. As you try your exercises for the first time, you should adjust the tension to the correct level before you begin your full workout. Turning the adjustment knob allows you to change the tension level and vary the intensity of your workout as you exercise. To increase tension turn the tension knob to the right and to decrease tension turn the tension knob to the left.

*Note:
Re-adjust the
Tension knob
after you finished
re-strapping.*

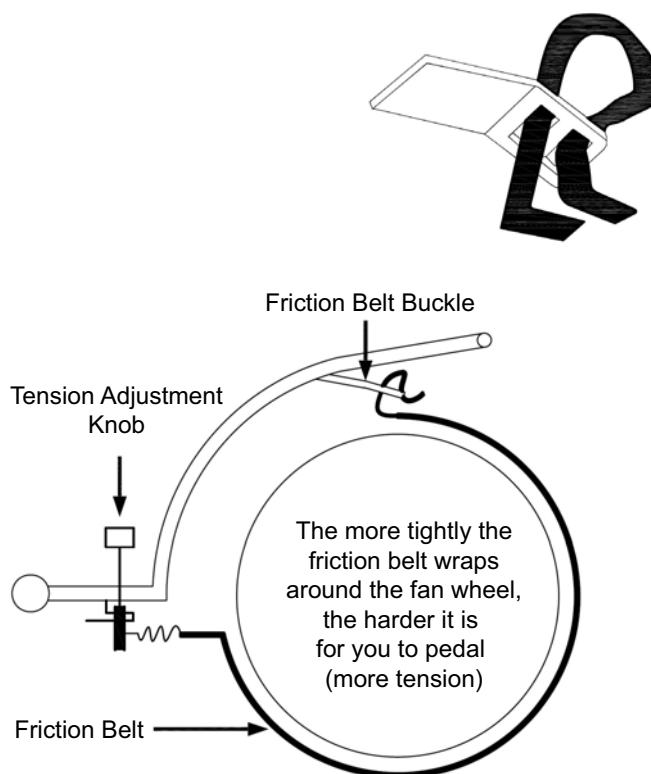
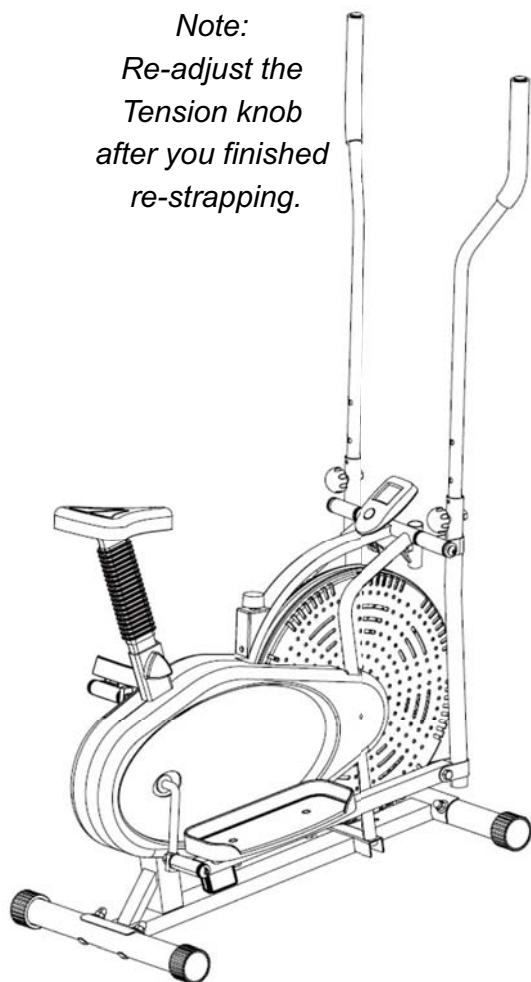

Reversible movement

Remember, your Elliptical Trainer has REVERSIBLE movement!

Forward pedaling exercises your quadriceps (front thigh muscles), while backward pedaling targets your hamstrings (back thigh muscles). Take advantage of these facts to make your workout less fatiguing and more fun.

CAUTION: MAKE SURE YOU HAVE TIGHTENED ALL THE BOLTS AND NUTS WELL BEFORE BEGINNING YOUR WORKOUT!

USING YOUR ELLIPTICAL TRAINER

Using your Elliptical Trainer will provide you with several benefits. It will improve your physical fitness, tone your muscles and in conjunction with a calorie controlled diet, help you lose weight.

Exercising Information

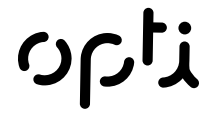

Free area & Training area

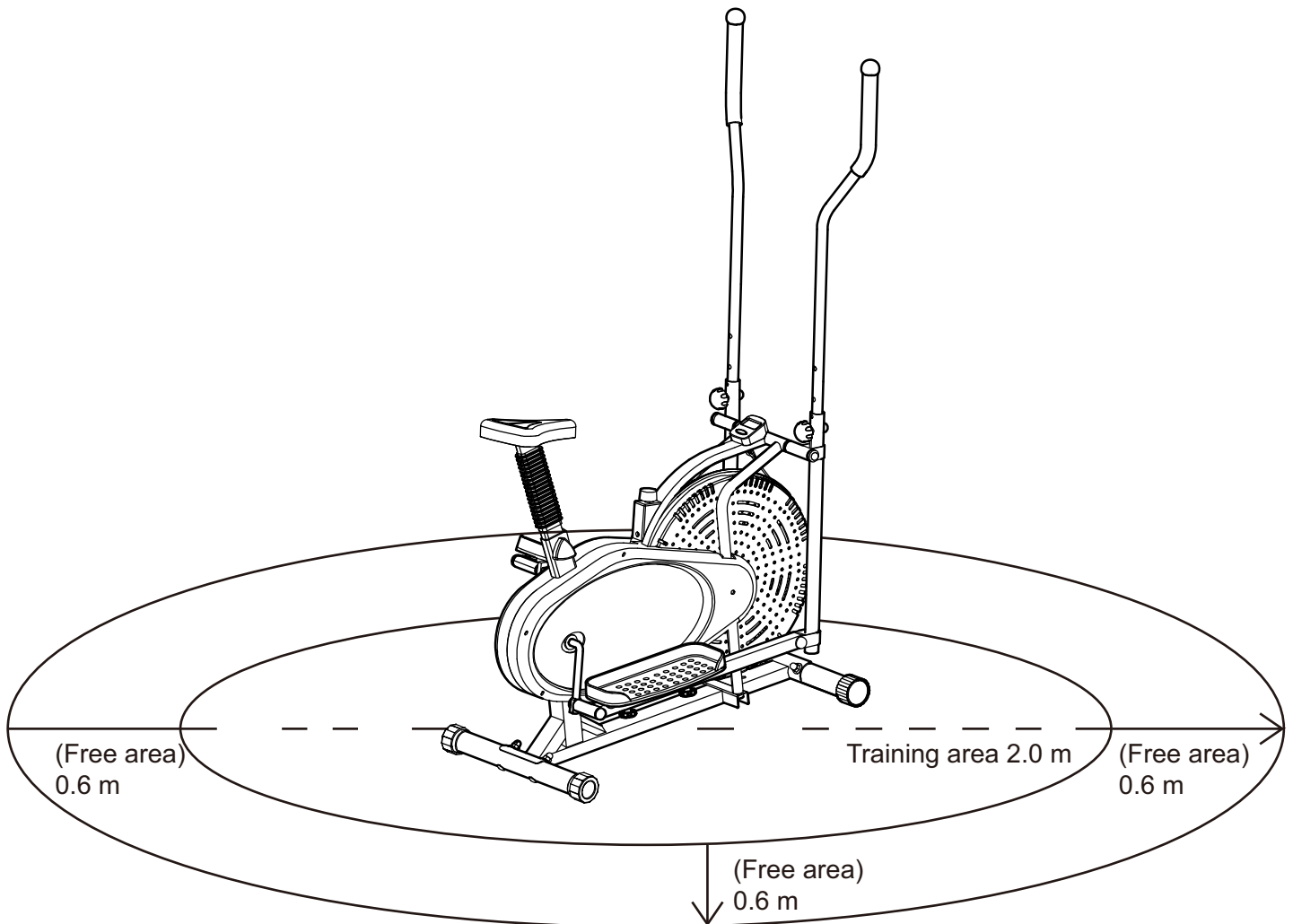

Important – Please read these instructions fully before using

The free area shall be not less than 0,6 m greater than the training area in the directions from which the equipment is accessed. The free area must also include the area for emergency dismount. Where equipment is positioned adjacent to each other the value of the free area may be shared.

Exercise Monitor User Instructions

Your Exercise Monitor has been specially designed to help you plan and view your exercise performance.

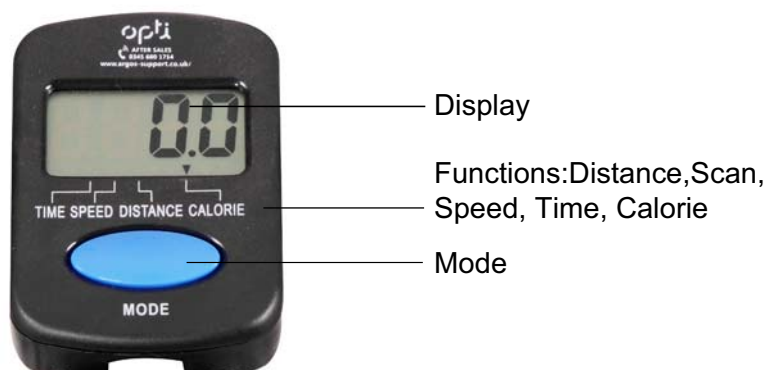

EXERCISE MONITOR FUNCTIONS:

Exercise Monitors have SOME or ALL the following functions: -
CALORIES ~ (COMPUTED THEORETICAL CALORIE BURN)
DISTANCE ~ (EXERCISE DISTANCE [KM])
SCAN ~ (CHANGING FROM FUNCTION TO FUNCTION)
SPEED ~ (CYCLE SPEED [KM/H])
TIMER ~ (COUNT UP [minutes and seconds])

MONITOR FUNCTION SPECIFICATIONS:

| | |
|-----------------|-------------------------------------|
| CALORIES | 0.00 - 9999 Kcal (THEORETICAL) |
| DISTANCE | KM(COUNT UP) |
| SCAN | SHOWS EACH FUNCTION EVERY 3 SECONDS |
| SPEED | 0.00 - 99.9 KM/H |
| TIMER | 0.00 - 99.59 MINUTES (COUNT UP) |

MONITOR FUNCTION SPECIFICATIONS:

| | |
|-------------------------------------|--------------------------|
| POWER SOURCE | 1x AAA(1.5v) POWER CELLS |
| STORAGE TEMPERATURE | -10c - +60c |
| NORMAL OPERATING TEMPERATURE | 0c - +50c |

USING YOUR EXERCISE MONITOR

To provide ease of use, there is only 1 button on your Exercise Monitor: - MODE

Press the MODE button to manually move through each of the Exercise Monitor's functions in turn. These are in order: - TIME, SPEED, DISTANCE and CALORIES. If you press the MODE button until you reach the SCAN mode and then release it, the display will change EVERY 6 SECONDS to show each function in turn.

Pressing and holding the MODE button when you are in any of the above functions will set to zero any previous figures remaining in each function.

Start to exercise and the Exercise Monitor will begin to register the various functions.

BATTERY INSTALLATION:

To fit the necessary BATTERIES - (NOT SUPPLIED) to your Exercise Monitor, remove the BATTERY COVER at the REAR of the monitor. Carefully fit the batteries by fitting between the exposed contacts in the battery compartment. Ensure that batteries are fitted with the '+' / '-' ends matching the outline on the sticker in the battery compartment or etched into the compartment. Failure to fit batteries correctly may result in damage to your Exercise Monitor, which is not covered by our guarantee. PLEASE DISPOSE OF OLD BATTERIES CAREFULLY

Exercising Information



Before starting to exercise

How you begin your exercise program depends on your physical condition. If you have been inactive for several years, or are severely overweight, you must start slowly and increase your time on the equipment; a few minutes per workout.

Initially, you may be able to exercise only for a few minutes in your target zone, however, your aerobic fitness will improve over the next six to eight weeks. Don't be discouraged if it takes longer. It's important to work at your own pace. Ultimately, you'll be able to exercise continuously for 30 minutes. The better your aerobic fitness, the harder you will have to work to stay in your target zone.

Please remember these essentials:

- Have your doctor review your training and diet programs to advise you of a workout routine you should adopt.
- Begin your training program slowly with realistic goals that have been set by you and your doctor.
- Monitor your pulse frequently. Establish your target heart rate based on your age and condition.

Exercise intensity

To maximize the benefits of exercising, it is important to exercise with the proper intensity. The proper intensity level can be found by using your heart rate as a guide. For effective aerobic exercise, your heart rate should be maintained at a level between 65% and 85% of your maximum heart rate as you exercise. This is known as your target zone. You can find your target zone in the table below.

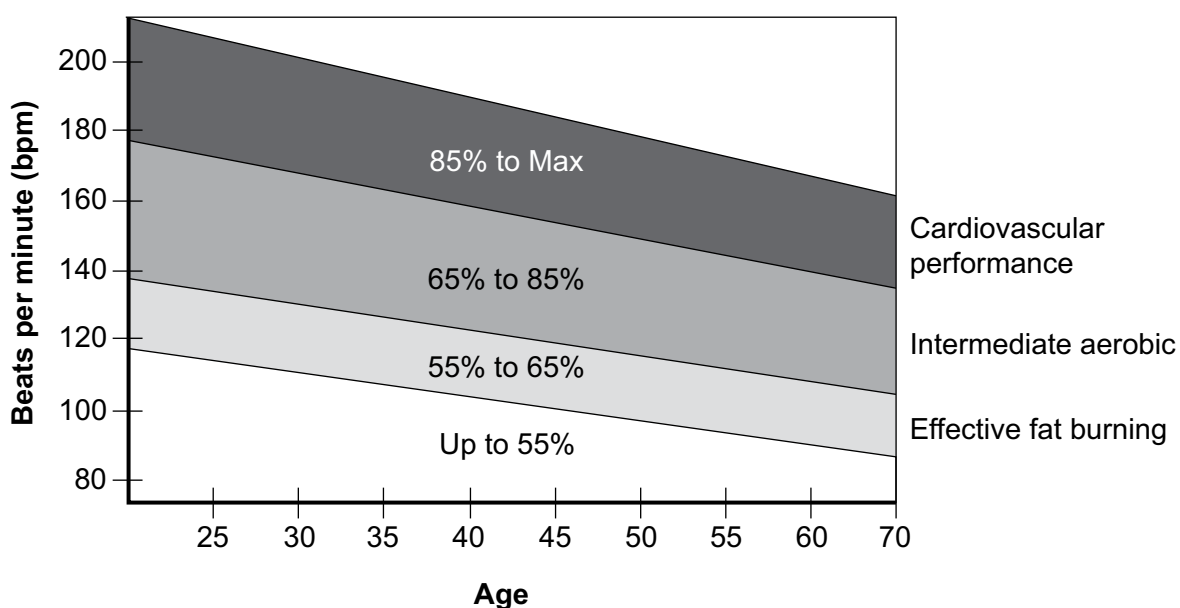

During the first few months of your exercise program, keep your heart rate near the low end of your target zone as you exercise. After a few months, your heart rate can be increased gradually until it is near the middle of your target zone as you exercise.

To measure your heart rate, stop exercising but continue moving your legs or walking around and place two fingers on your wrist. Take a six-second heartbeat count and multiply the results by 10 to find your heart rate. For example, if your six-second heartbeat count is 14, your heart rate is 140 beats per minute. (A six-second count is used because your heart rate will drop rapidly when you stop exercising.) Adjust the intensity of your exercise until your heart rate is at the proper level.

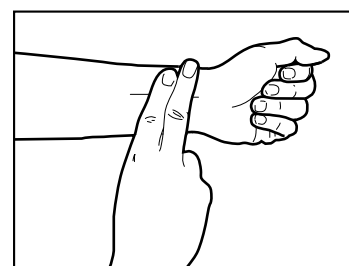

Exercising Information

Muscle chart

Aerobic Exercise

Aerobic exercise improves the fitness of your lungs and heart - your body's most important muscle. Aerobic exercise fitness is promoted by any activity that uses your large muscles (arms, legs, or buttock, for example). Your heart beats quickly and you breathe deeply. An aerobic exercise should be part of your entire exercise routine.

Weight Training

Along with aerobic exercising which helps get rid of and keep off the excess fat that our bodies can store, weight training is an essential part of the exercise routine process. Weight training helps tone, build and strengthen muscle. If you are working above your target zone, you may want to do a lesser amount of reps. As always, consult your doctor before beginning any exercise program.

Targeted Muscle Groups

The exercise routine that is performed on the Air Cross Trainer will develop the upper and lower body muscle groups. These muscle groups are highlighted on the muscle chart below.

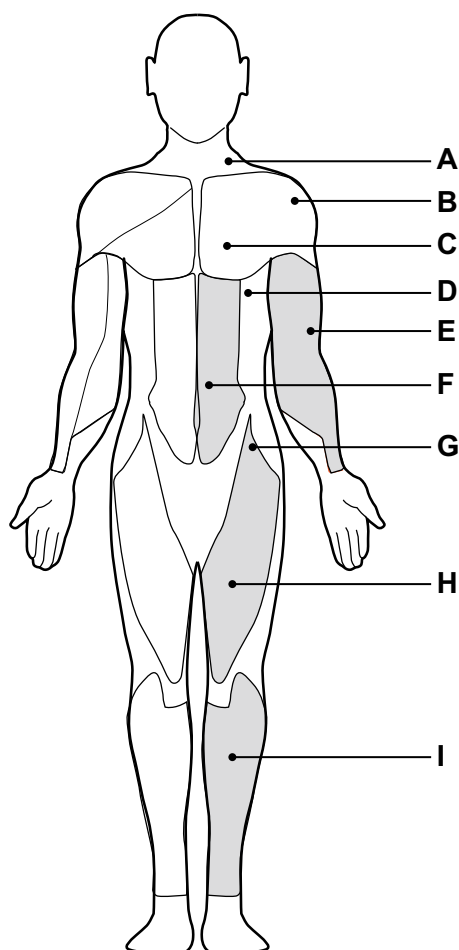

Front

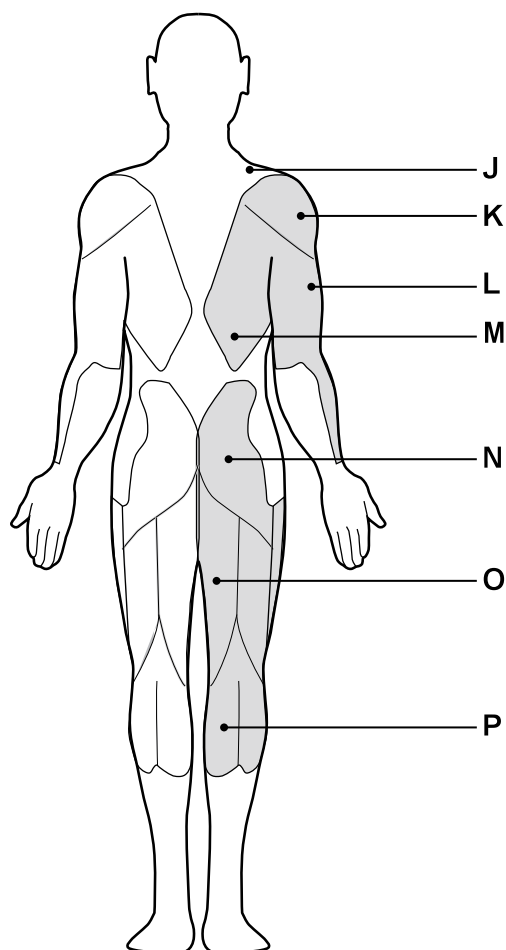

Back

A: Trapezius

B: Anterior

C: Pectoralis Major

D: Serratus Anterior

E: Biceps

F: Abdominal

G: Sartorius

H: Quadriceps

I: Tibialis

J: Trapezius

K: Posterior

L: Triceps

M: Latissimus Dorsi

N: Gluteals

O: Hamstrings

P: Gastrocnemius

Warming up and Cooling down exercises

Each workout should include the following three parts:

1. A warm-up, consisting of 5 to 10 minutes of stretching and light exercise. A proper warm-up increases your body temperature, heart rate, and circulation in preparation for exercise.
2. Training zone exercise, consisting of 20 to 30 minutes of exercising with your heart rate in your training zone. (**Note:** During the first few weeks of your exercise program, do not keep your heart rate in your training zone for longer than 20 minutes.)
3. A cool-down, with 5 to 10 minutes of stretching. This will increase the flexibility of your muscles and will help to prevent post-exercise problems.

Exercise Frequency

To maintain or improve your condition, plan three workouts each week, with at least one day of rest between workouts. After a few months of regular exercise, you may complete up to five workouts each week, if desired. Remember, the key to success is make exercise a regular and enjoyable part of your everyday life.

Suggested Stretches

For a correct warm up, see the following basic stretching exercises. Move slowly as you stretch, never bounce.

Toe touch stretch

Stand with your knees bent slightly and slowly bend forward from your hips. Allow your back and shoulders to relax as you reach down toward your toes as far as possible.

Hold for 15 counts, then relax.

Repeat 3 times.

Stretches: Hamstrings, back of knees and back.



Hamstring stretch

Sit with one leg extended. Bring the sole of the opposite foot toward you and rest it against the inner thigh of your extended leg. Reach toward your toes as far as possible.

Hold for 15 counts, then relax.

Repeat 3 times for each leg.

Stretches: Hamstrings, lower back and groin.

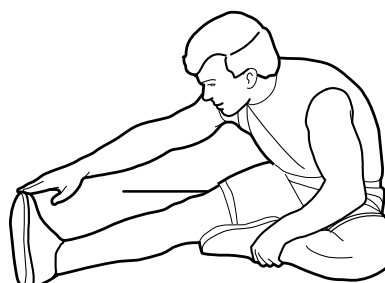

Exercising Information

Calf/achilles stretch

With one leg in front of the other, reach forward and place your hands against a wall. Keep your back leg straight and your back foot flat on the floor. Bend your front leg, lean forward and move your hips toward the wall.

Hold for 15 counts, then relax.

Repeat 3 times for each leg. To cause further stretching of the achilles tendons, bend your back leg as well.

Stretches: Calves, achilles tendons and ankles.

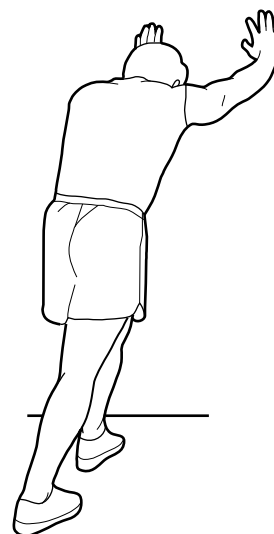

Quadriceps stretch

With one hand against the wall for balance, reach back and grasp one foot with your other hand. Keeping your bent knee pointing directly downward towards the floor, gently pull your heel towards your buttock until you feel a gentle stretch in the target area.

Hold for 15 counts, then relax.

Repeat 3 times for each leg.

Stretches: Quadriceps and hip muscles.

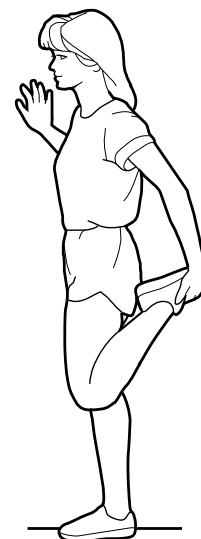

Inner thigh stretch

Sit with the soles of your feet together and your knees outward. Pull your feet toward your groin area as far as possible.

Hold for 15 counts, then relax.

Repeat 3 times.

Stretches: Quadriceps and hip muscles.

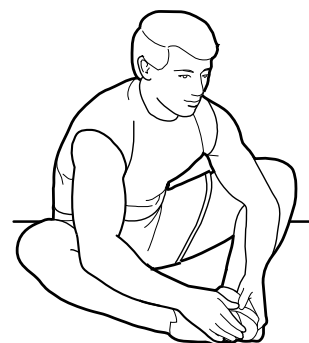

1. The safety level of the equipment can be maintained only if it is examined regularly for damage and wear, e.g. ropes, pulleys, connection points

2. Special attention to components most susceptible to wear.

Lubricate moving parts with light oil periodically to prevent premature wear.

3. Replace defective components immediately and/or keep the equipment out of use until repair.

4. The equipment can be cleaned using a damp cloth and mild non-abrasive detergent. **Do not** use solvents.

5. **Do not** attempt to repair this equipment yourself. Should you have any difficulty with

assembly, operation or use of your exercise product or if you think that you may have parts missing, contact the manufacturer, their approved service agent or the **Customer Helpline: 0345 600 1714** www.argos-support.co.uk

Guarantee:

For guarantee purposes, please retain your purchase receipt.

Information for Users on Disposal of old Equipment and Batteries (European Union only)

These symbols indicate that equipment with these symbols should not be disposed of as general household waste. If you want to dispose of the product or battery, please consider the collection systems or facilities for appropriate recycling.

Notice: The sign Pb below the symbol for batteries indicates that this battery contains lead.



Products



Battery

Exploded Parts Diagram

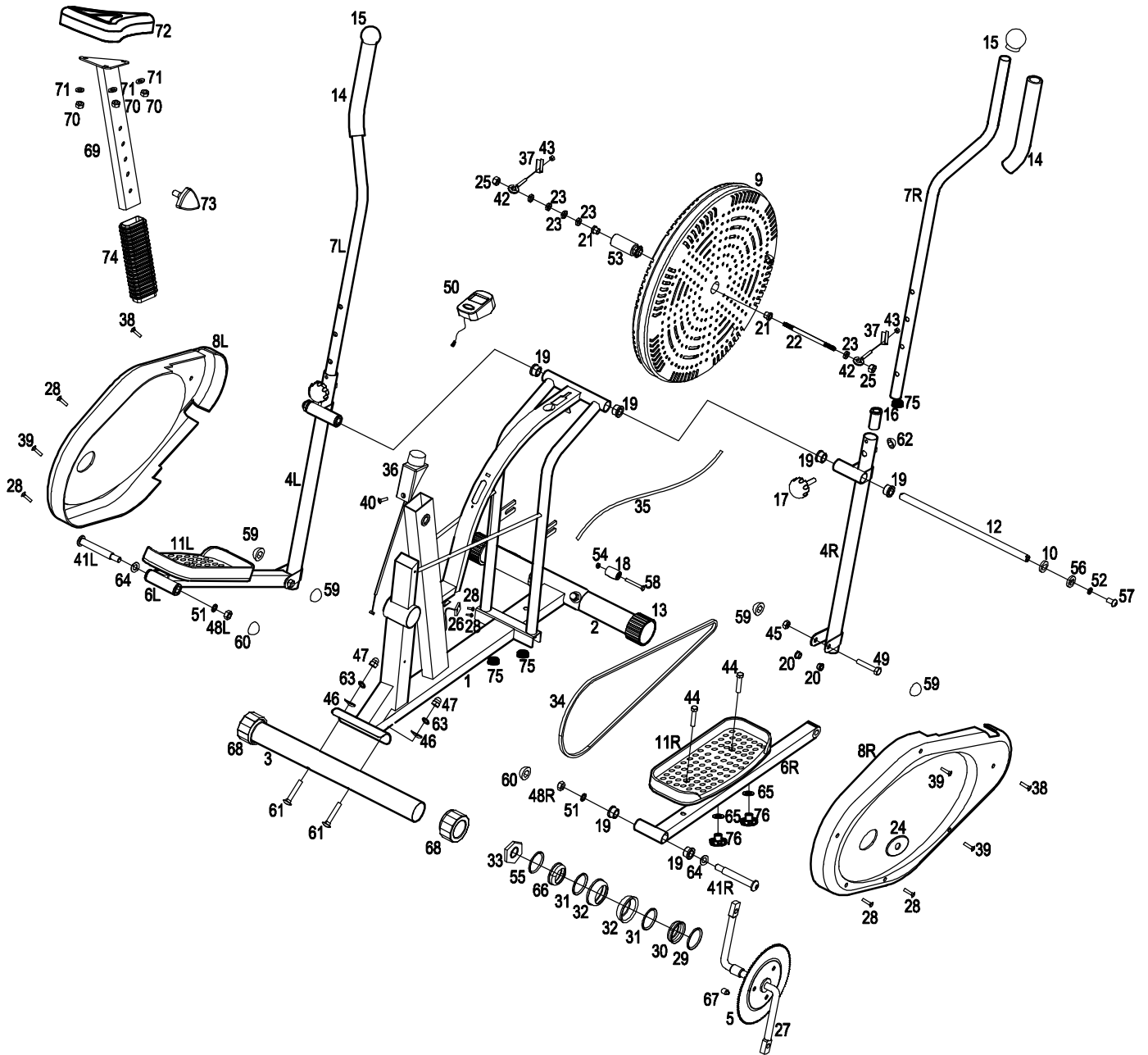

Parts List



| No. | Description | QTY | NO. | Description | QTY | NO. | Description | QTY |
|-------|-------------------|------|-------|-----------------------------------|------|-----|------------------|-----|
| 1 | Main frame | 1 | 35 | Belt | 1 | 71 | Washer D8 | 3 |
| 2 | Front bottom tube | 1 | 36 | Tension control | 1 | 72 | Saddle | 1 |
| 3 | Back bottom tube | 1 | 37 | U Sharp Washer | 2 | 73 | Triangle knob | 1 |
| 4L/R | couple bar | 1pr. | 38 | Bolt ST4.2x20 | 2 | 74 | Seat post Sleeve | 1 |
| 5 | Chain 25Hx22L | 1 | 39 | Bolt ST4.2x20 | 3 | 75 | Cap | 4 |
| 6L/R | pedal tube | 1pr. | 40 | Bolt | 1 | 76 | Knob | 4 |
| 7L/R | handle bar | 1pr. | 41R/L | Pedal hinge bolt φ16*111.8 | 1pr | | | |
| 8L/R | chain cover | 1pr. | 42 | Bolt | 2 | | | |
| 9 | Fan cover | 1 | 43 | Nut | 2 | | | |
| 10 | Washer φ16×1×φ28 | 1 | 44 | Hex Bolt M10X45 | 4 | | | |
| 11L/R | Pedal | 1pr. | 45 | Nylon Nut M10 | 2 | | | |
| 12 | Handle bar shaft | 1 | 46 | Arc washer D10 | 4 | | | |
| 13 | Front caps | 2 | 47 | Acorn nut M10 | 4 | | | |
| 14 | Foam grips | 2 | 48L/R | Nylon nut B0.5X20 | 1pr. | | | |
| 15 | Cap | 2 | 49 | Bolt M10X55 | 2 | | | |
| 16 | Plastic bushing | 2 | 50 | Computer | 1 | | | |
| 17 | Knob bolt | 2 | 51 | Spring washer 13*B2 | 2 | | | |
| 18 | Plastic roller | 2 | 52 | Spring washer φ10.5 | 2 | | | |
| 19 | Steel bushing | 10 | 53 | Chain wheel | 1 | | | |
| 20 | Steel bushing | 4 | 54 | Nylon nut | 2 | | | |
| 21 | Nut | 2 | 55 | Washer | 1 | | | |
| 22 | Fan wheel axle | 1 | 56 | D shape washer φ28xφ16.2x14XB5 | 2 | | | |
| 23 | Nut | 5 | 57 | Bolt M10X18 | 2 | | | |
| 24 | Plastic cover | 2 | 58 | Bolt | 2 | | | |
| 25 | Nut | 2 | 59 | Plastic cap S16 | 4 | | | |
| 26 | Sensor | 1 | 60 | Plastic cap S18 | 2 | | | |
| 27 | Crank | 1 | 61 | Carriage bolt M10×L63 | 4 | | | |
| 28 | Bolt ST4.2x18 | 6 | 62 | Plastic cap S13 | 2 | | | |
| 29 | Washer | 1 | 63 | Spring washer D10 | 4 | | | |
| 30 | Nut | 1 | 64 | Wave washer φ28xφ16x0.3 | 2 | | | |
| 31 | Collar ball | 2 | 65 | Flat washer D10 | 4 | | | |
| 32 | Collar housing | 2 | 66 | Nut | 1 | | | |
| 33 | Nut | 1 | 67 | magnet | 1 | | | |
| 34 | Chain | 1 | 68 | End caps | 2 | | | |
| | | | 69 | Seat tube | 1 | | | |
| | | | 70 | Nylon nut M8 | 3 | | | |

Guarantee



Product Guarantee

This product is guaranteed against manufacturing defects for a period of



This product is guaranteed for twelve months from the date of original purchase. Any defect that arises due to faulty materials or workmanship will either be replaced, refunded or repaired free of charge where possible during this period by the dealer from whom you purchased the unit.

The guarantee is subject to the following provisions:

- The guarantee does not cover accidental damage, misuse, cabinet parts, knobs or consumable items.
- The product must be correctly installed and operated in accordance with the instructions contained in this manual.
- It must be used solely for domestic purpose.
- The guarantee will be rendered invalid if the product is re-sold or has been damaged by inexpert repair.
- Specifications are subject to change without notice.
- The manufacturer disclaims any liability for the incidental or consequential damages.
- The guarantee is in addition to, and does not diminish your statutory or legal rights.
- In the event of a problem with the product within the guarantee period call the **Customer Helpline: 0345 600 1714 www.argos-support.co.uk**

Guarantor: Argos Ltd
489 - 499 Avebury Boulevard
Central Milton Keynes
MK9 2NW