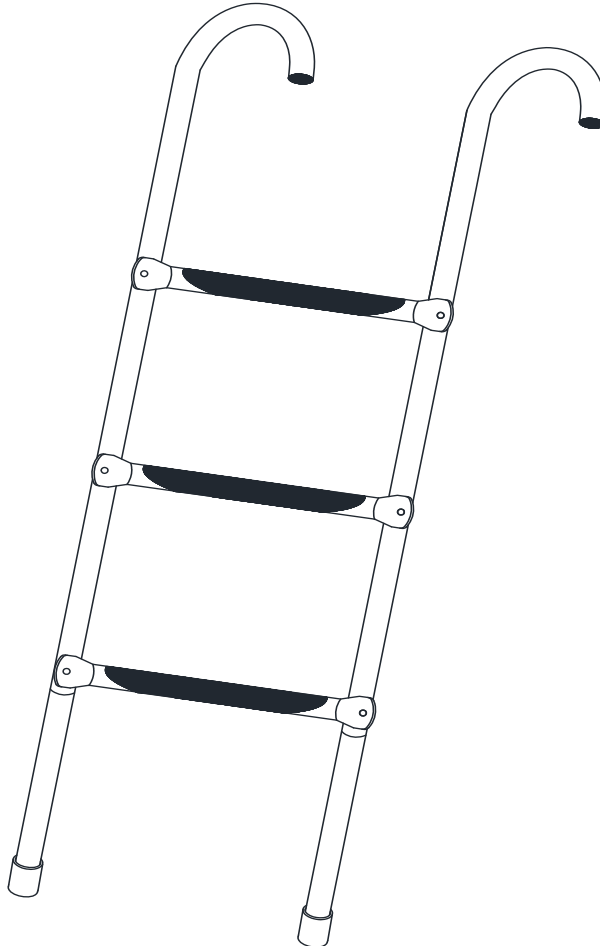

Ladder for 12ft/14ft Trampoline

Assembly Instructions

**⚠ WARNING**

This ladder is subject to 100kg weight limit.

Do not allow more than one person on the ladder at a time.

Do not allow young children to use unless supervised by an Adult.

For Customer Service, please call (+44) 03300 904420

or visit www.sportspowerfit4kids.com







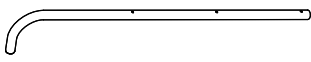
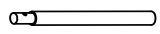

Monday – Friday 8:00 AM – 5:00 PM

Sportspower Ltd.



20/F, Parkview Centre, 7 Lau Li Street, Causeway Bay, Hong Kong

Corporate Office: us toll free 1-800-497-6106

Parts List

Key Number	Description	Diagram	Qty
A	Cane Shaped Frame Tube		2
B	Extension Frame Tube		2
C	Foot Tread Tube		3
D	Screws		6
E	Cap Nut		6
F	Arc Washer		12
G	Inner End Cap		2
H	Outer End Cap		2
I	Safety Instruction Placard		1
J	Spring Washer		6

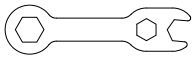
● Same as the trampoline for below parts.

Description	Diagram	Qty
Wrench		1
Allen Wrench		1

IMPORTANT

Use the above parts list to make sure all parts are present before assembling the ladder.

Do not attempt to assemble the ladder if any parts are missing or damaged.

If any parts are missing or damaged, please call the helpline number (+44) 03300 904420 for assistance.

Before you start to assemble...

- Please read the instructions carefully.
- Please dispose of all polyethylene packing material properly and keep it away from children.
- When you are ready to start, make sure you have the right tools to hand.
- Retain this Assembly Instructions for future use.

ASSEMBLY INSTRUCTION

STEP 1

Connect the assembled Extension Frame Tube (# B) to Cane Shaped Frame Tube (# A), and then insert Inner End Cap (# G) and Outer End Cap (# H) into the ends of Cane Shaped Frame Tubes (# A) as shown in FIGURE 1.

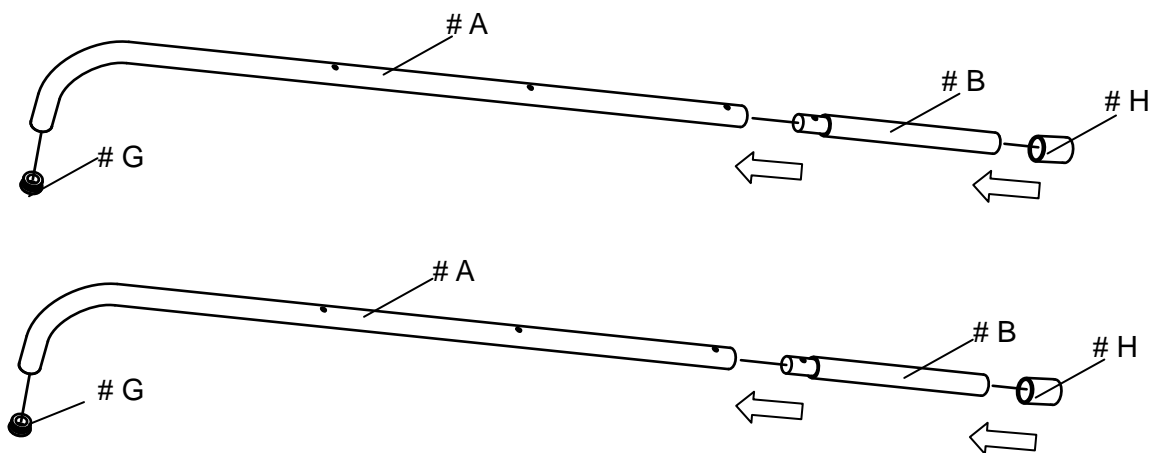

FIGURE 1

STEP 2

Attach Foot Tread Tubes (# C) with Screws (# J), Arc Washer (# F), Spring Washer (# O) and Cap Nut (# E). Tighten using Allen Wrench while holding the other end with Wrench (# D). Please note the "ARC" OF Foot Tread Tube (# C) should face Cane Shaped Frame Tube (# A) as shown in FIGURE 2.

- The Allen Wrench and Wrench included in Trampoline with enclosure Assembly Instructions.

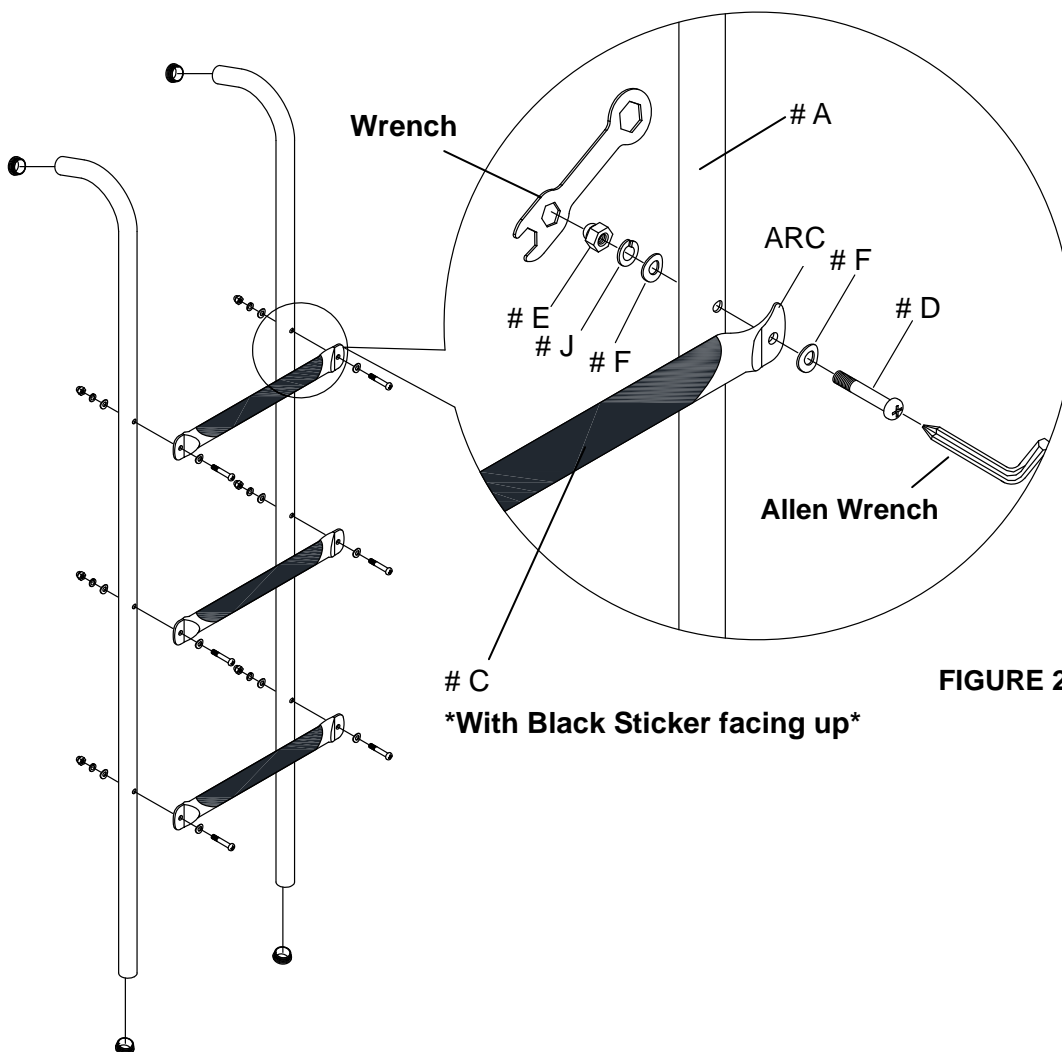

FIGURE 2

With Black Sticker facing up

STEP 3

Position the ladder by the doorway where you can enter / exit the trampoline:

- A. Lift the padding and hook the ladder onto the trampoline frame.
- B. Ensure the ladder does not interfere with the ties, springs or mat.
- C. Cover top of the ladder by padding.

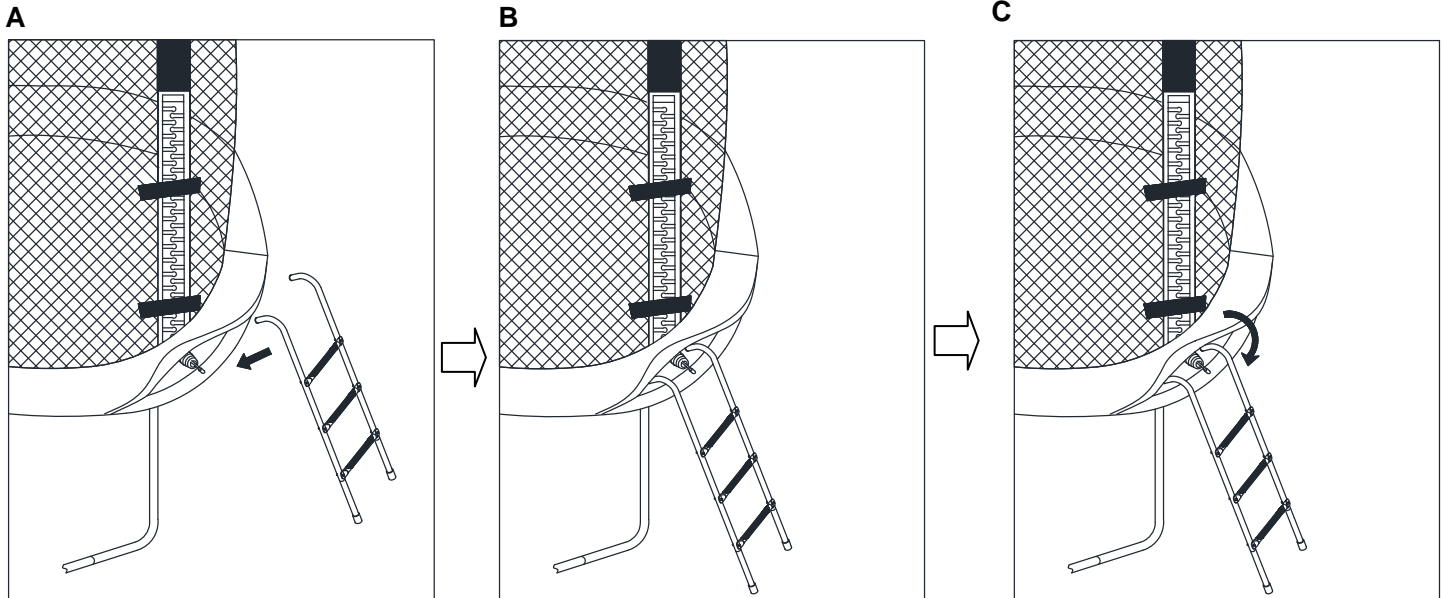

STEP 4

Use the plastic tie provided to attach Ladder Safety Instruction Placard (# 1) to the ladder as shown in FIGURE 3.

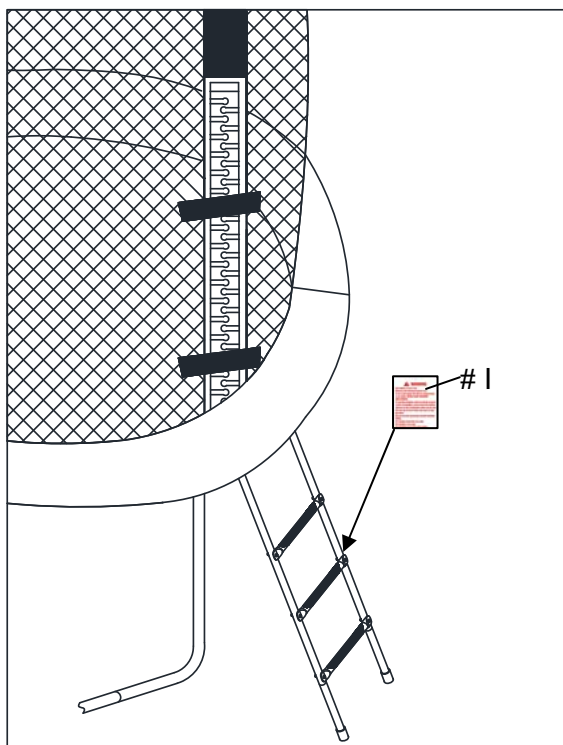

FIGURE 3

IMPORTANT : Please ensure the ladder is hooked securely onto the trampoline frame before use.

Care and Maintenance Instructions:

Inspect the ladder before each use and replace any worn, defective or missing parts.
Regularly check that all bolts are tightened.
Do not leave the ladder outdoor when not in use.
The ladder should be stored in a dry covered area when not in use.

WARNING

- To be used under the direct supervision of an adult. Never leave children unattended.
- To avoid accidents and to restrict access to the trampoline, never leave the ladder placed on the trampoline when not in use.
- For use by no more than one user at any one time.
- Do not exceed maximum weight loading 100 kg.
- Warning. For family domestic use only.
- For outdoor use only.
- No jumping on or from ladder.
- The ladder is not a toy.
- Remove all footwear before use.
- To be used under the direct supervision of an adult. **NEVER LEAVE CHILDREN UNATTENDED.**