

OPTI Folding Manual Treadmill

Assembly & User Instruction – Please keep for future reference

612/7743

opti

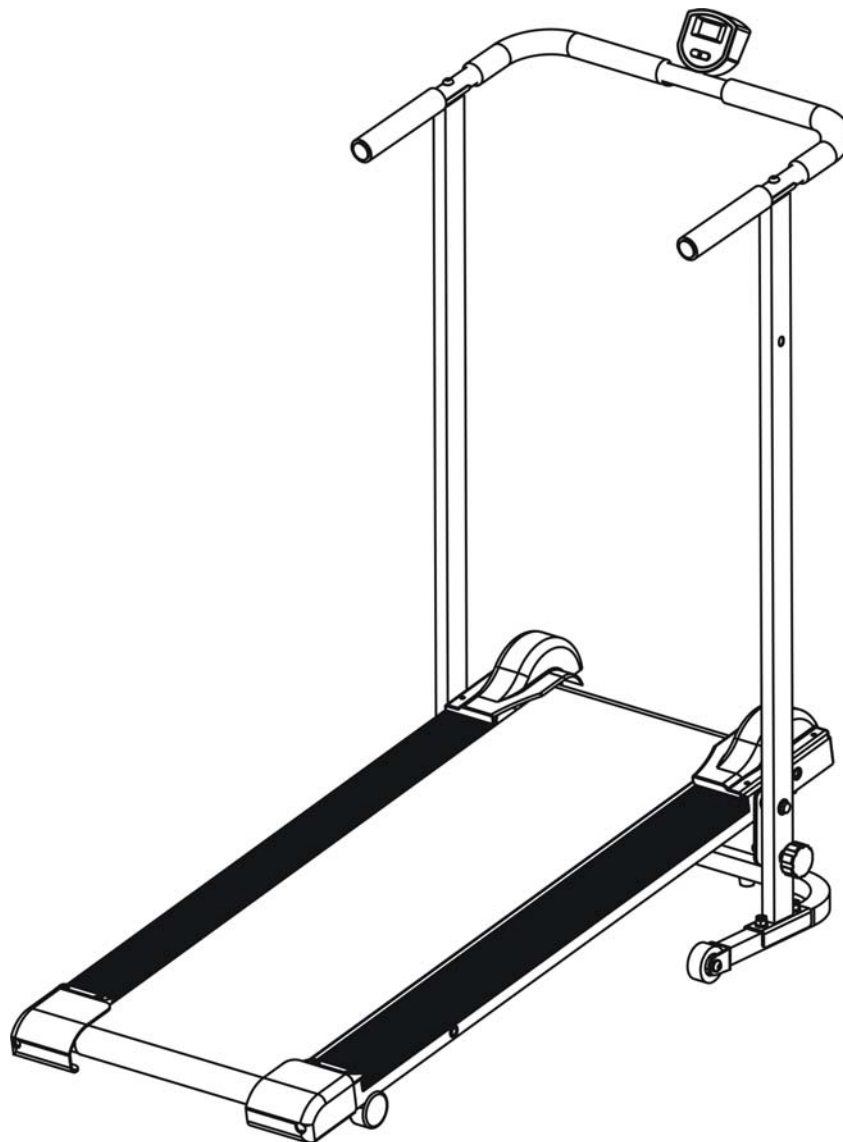

Important – Please read these instructions fully before assembly or using

These Instructions contain important information which will help you get best from your equipment and ensure safe and correct assembly, use and maintenance.

If you need help or have damaged or missing parts, call the **Customer Helpline: 0345 6001714**
<http://www.argos-support.co.uk>

Contents

Safety Information	3
Components - Parts	4
Components – Fixing	5
Assembly Instruction	6
Free area and training area	10
Computer Operation	11
Exercising Information	13
* Before Starting to exercise	13
* Muscle Chart	14
* Warming up and Cooling down	15
Care and Maintenance	17
Exploded Parts Diagram	18
Exploded Parts List	19
Guarantee	20

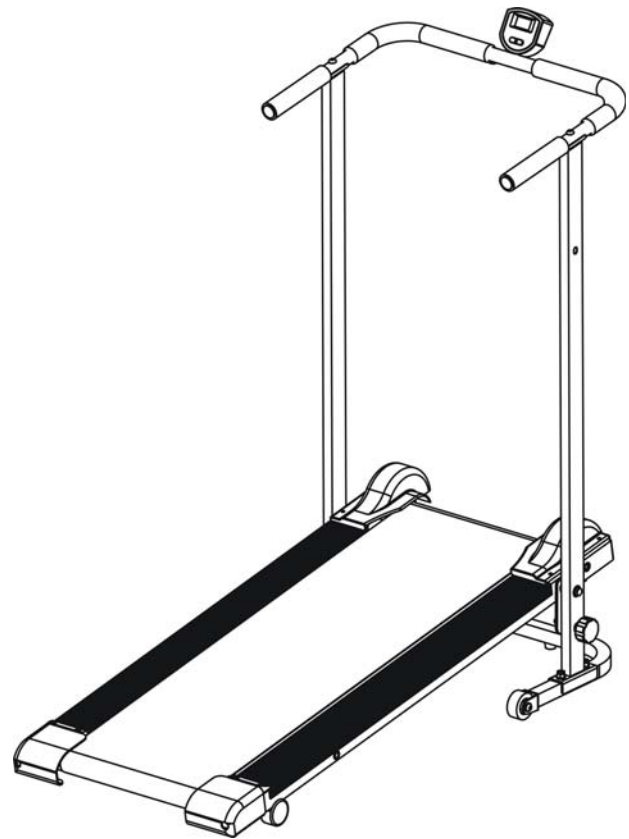



Safety Information



Important – Please read fully before using and assembly

To reduce the risk of serious injury, read the entire manual before you assemble or operate the Pro Fitness Folding Manual Treadmill, In particular, note the following safety precautions:

Assembly

- Check you have all the components and tools listed on pages 3 and 4, bearing in mind that, for ease of assembly, some components are pre-assembled.
- Keep children and animals away from the work area, small parts could choke if swallowed.
- Make sure you have enough space to layout the parts before starting.
- Assemble the item as close to its final position (in the same room) as possible.
- Position the equipment on a clear, level surface.
- Dispose of all packaging carefully and responsibly.

Using

- It is the responsibility of the owner to ensure that all users of this product are properly informed as to how to use this product safely.
 - This product is intended for domestic use only. **Do not** use in any commercial, rental, or institutional setting.
 - Before using the equipment to exercise, always do stretching exercises to properly warm up.
 - If the user experiences dizziness, nausea, chest pain, or other abnormal symptoms **stop the workout and seek immediate medical attention.**
 - Clear safety area of at least 2 000 mm in length and at least as wide as the treadmill shall be provided behind the equipment when in use

- Only one person at a time should use the equipment.
- Keep hands away from all moving parts.
- Always wear appropriate workout clothing when exercising. **Do not** wear loose or baggy clothing, since it may get caught in the equipment. Wear athletic shoes to protect your feet while exercising.
- **Do not** place any sharp objects around the equipment.
- Disabled persons should not use the equipment without a qualified person or doctor in attendance.
- This product is suitable for user's weight of: **100kgs.**

• This product conforms to: BS EN ISO 20957-1 and BS EN 957-6. Class (H) - Home Use - Class (C).

- This exercise product has been designed and manufactured to comply with the latest (BS EN 957) British and European Safety Standards.

Battery safety

- **Warning:** Incorrect installation of batteries may cause battery leakage and corrosion, resulting in damage to the computer.
- **Do not** mix old and new batteries, or batteries of different types.
- **Do not** dispose of batteries in a fire.
- **Do not** dispose of batteries with normal household waste, take to a local recycling centre



Warning: Before beginning any exercise program, consult your Doctor. This is especially important for persons over the age of 35 or persons with pre-existing health problems. You **MUST** read all instructions before using any fitness equipment. Argos and its associates assumes no responsibility for personal injury or property damage sustained by or through the use of this product.

Components-parts

If you have damaged or missing parts, please call the Customer Helpline: : **0345 6001714**

Please check you have all parts listing below

Note: Some of the smaller components may be pre-fitted to larger components. Please check carefully before contacting Argos regarding any missing components.



1. Main Frame ×1



2. Handlebar ×1

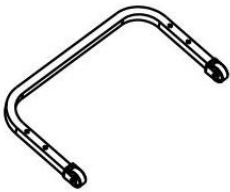

3. Base Frame ×1

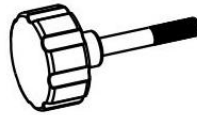

19. M8×55 Knob ×2









25. Computer ×1

Component – Fixing

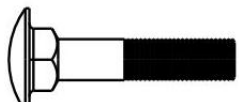
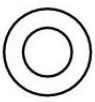

Please check you have all parts listing below

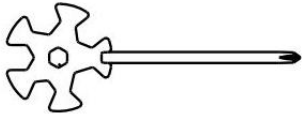
Note: Some of the fixings are pre-fitted to the larger components. Please check carefully before contacting Argos regarding any missing fixings.

<p>30</p>  <p>M8x40mm Carriage Bolt× 4</p>	<p>42</p>  <p>Φ8 Washer× 4</p>	<p>45</p>  <p>M8 Aircraft Nut× 4</p>
<p>31</p>  <p>M8x40mm Allen Bolt× 2</p>	<p>43</p>  <p>Φ8 Arc Washer× 2</p>	
 <p>Multi Wrench × 1</p>	 <p>5mm Allen Key × 1</p>	



Ruler - Use this ruler to help correctly identify the hardware

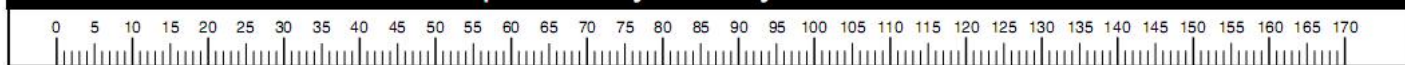

Note: Cut out this page to help fixing identification during assembly.

Assembly Instruction

Recommend two person assemble this product

Note: Carefully unpack each component, checking against the parts list that you have all the necessary parts to complete the assembly of your product.

Please note that some of the parts may be pre-fitted to major components, so please check carefully before assembling.

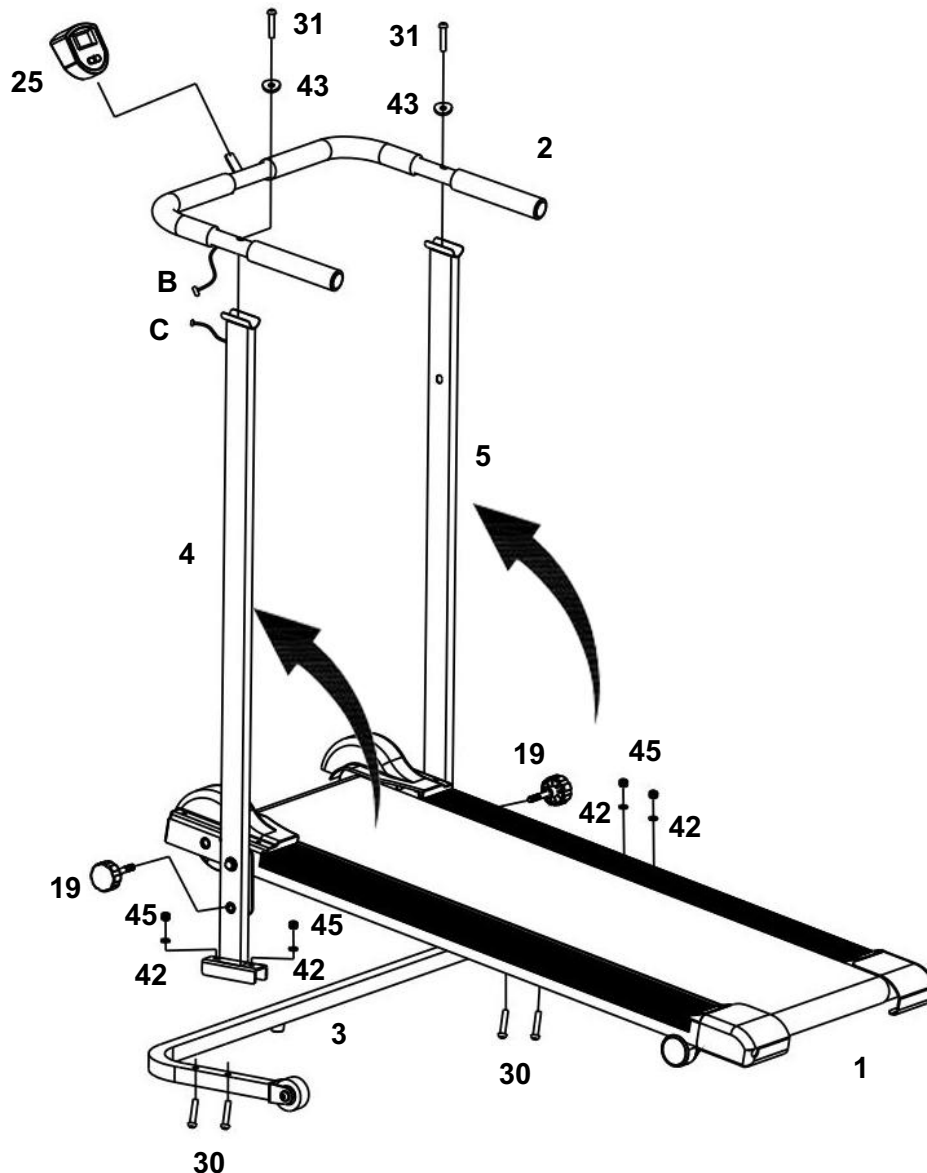

Step 1

- Raise the Left /Right Console Mast (4/5) to the upright position and secure each of them in a place using M8×55 Knob (19).
- Attach Left /Right Console Mast (4/5) onto the Base Frame (3), align the hole and secure each of them with four M8×40mm Carriage Bolt(30), four Φ 8 Washer (42) and four M8 Aircraft Nut(45).
- Attach the Handlebar (2) onto the Left /Right Console Mast (4/5) and secure in place using two M8×40mm Allen Bolt(31) and two Φ 8 Arc Washer(43).
- Fit 2 x AA batteries supplied into the back of the Computer (25).
- Connect the Sensor Wire (C) and (B) together, and then connect the Sensor Wire (B) to the back of the Computer (25). Slide the Computer (25) onto the Bracket until it is firmly locked.

Assembly Instruction



Foldable to save storage space

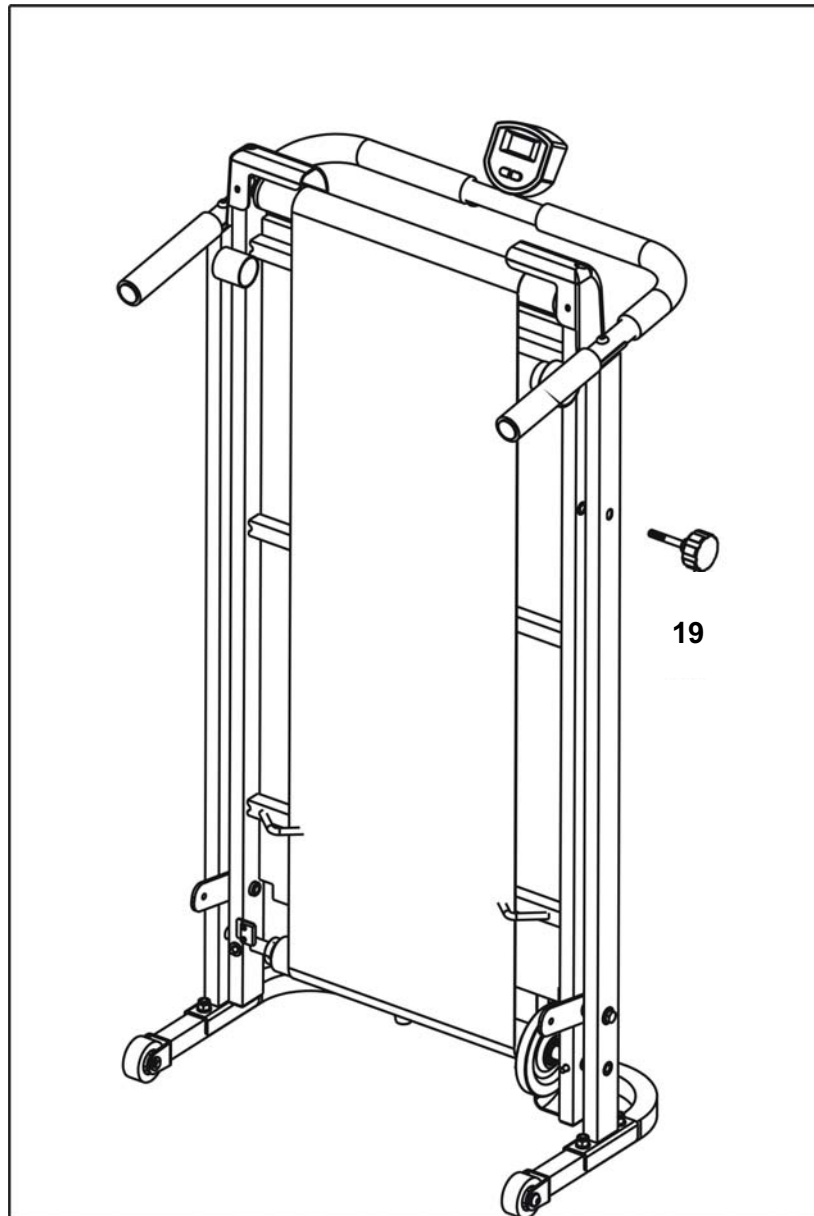

Your Treadmill can be folded down for easy storage or transportation.

- a) Simply remove two M8x55mm Knob (19), fold the Handlebar Frame down until the hole in the side of the Frame aligns with the hole in the side of the Treadmill.
- b) Lock the Frame in the position using one M8x55 Knob(19)
- c) You will find the Treadmill easy to move by pulling the Handlebar towards your body and wheeling it along on the castors.

Assembly Instruction

Adjusting the belt tracking

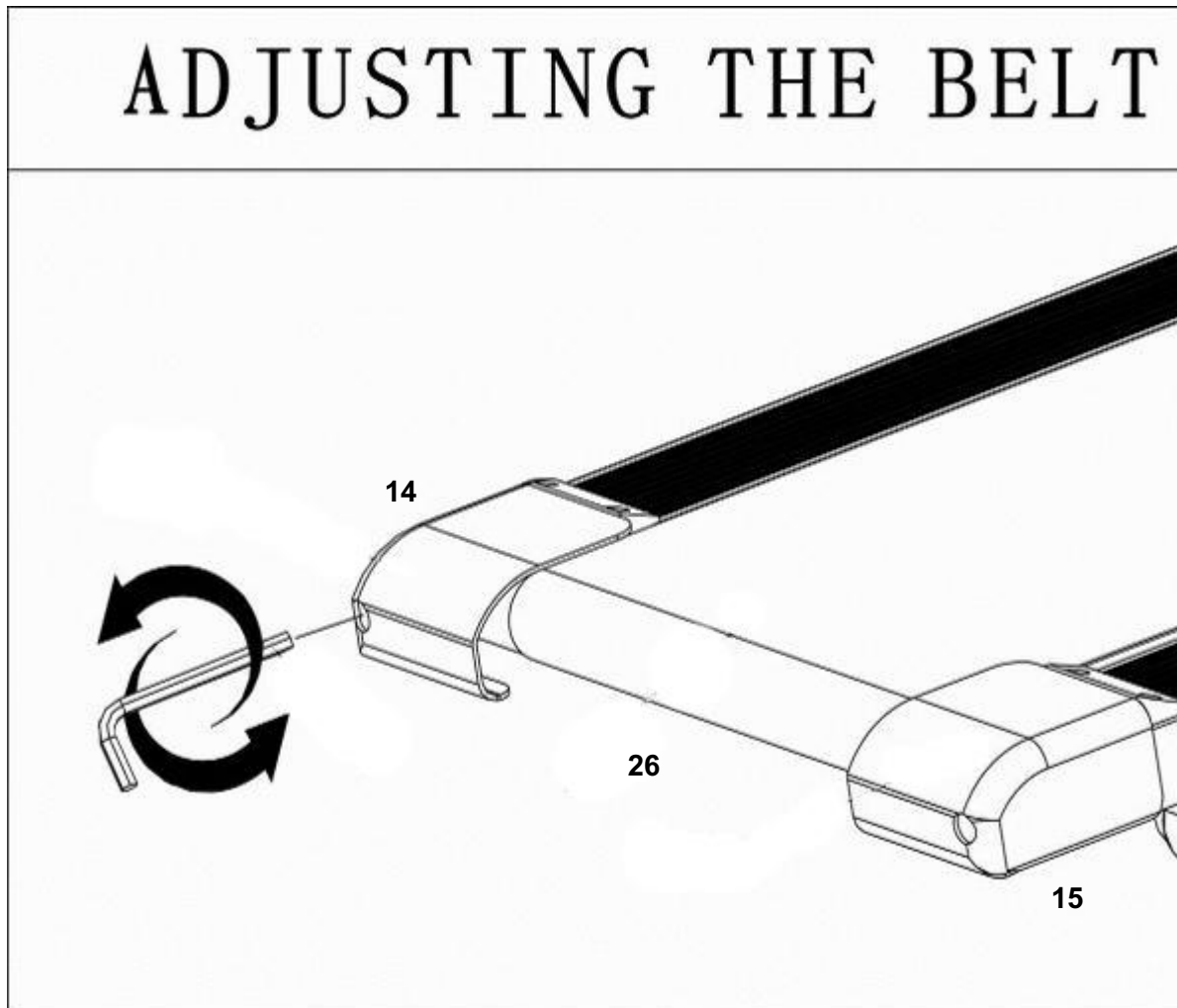

Adjusting the running belt – centered

- When using the Treadmill for the first time you may find the Running Belt(9) moves to one side. This can be easily overcome using the Belt Adjustment Bolts located at the rear of the Base Frame.
- If the Belt runs to the right you will need to adjust the Adjustment Bolt on the Right Rear Base Frame by turning it half a turn it half a turn (Clockwise) using 5# Allen Key (Supplied). Test the Belt for 1-2 minutes the Belt is still not running centrally do not tighten the right bolt again. Adjust the Adjustment Bolt on the Left Rear Base Frame one half a turn (Counter Clockwise)
- Now test it again for 1-2 minutes.

Assembly Instruction

Belt Adjustment

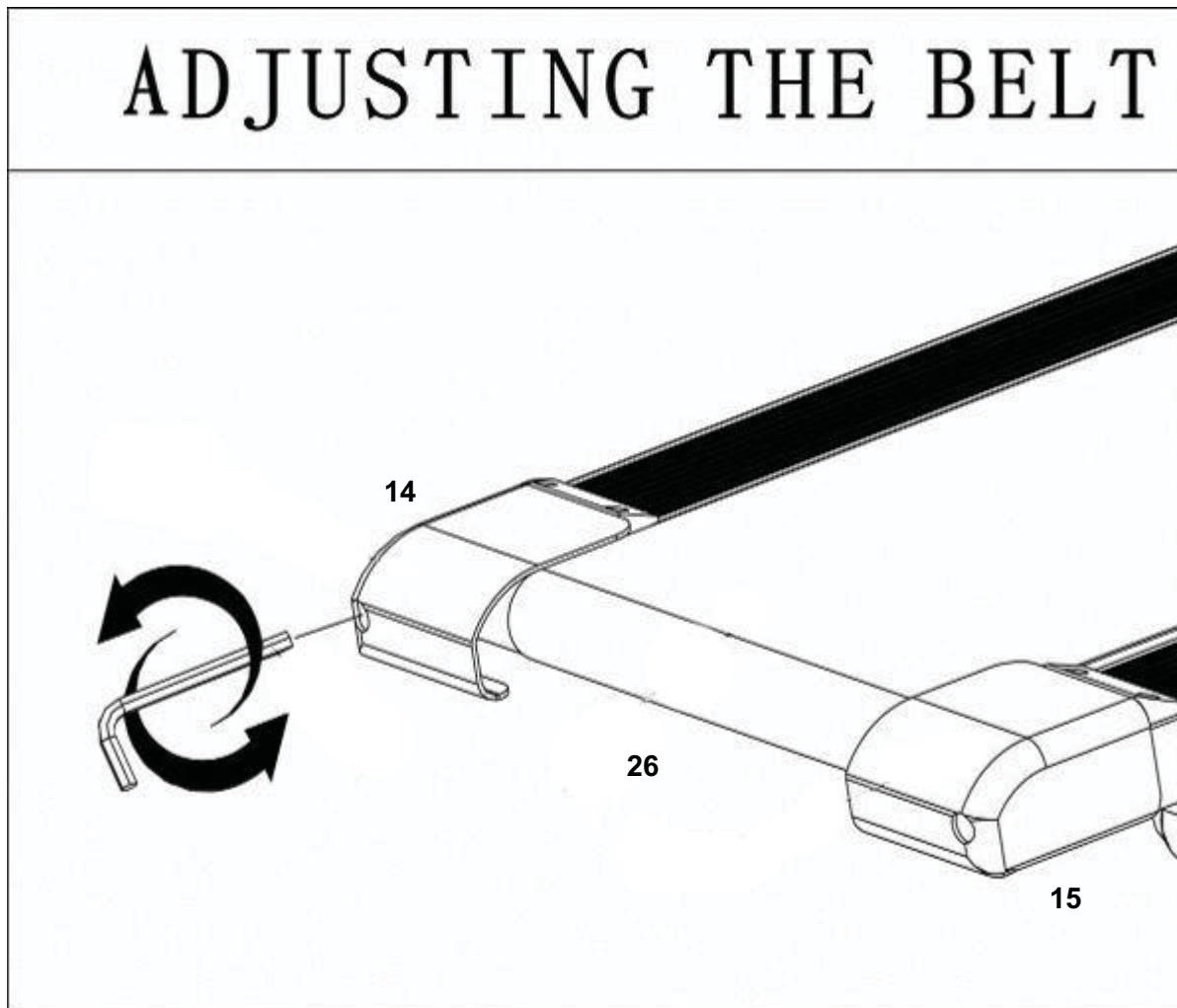

Adjusting the running belt – tension

If the Belt is too loose, turn (Clockwise) both Adjustment Bolts one half a turn each.
If it is still too loose, then turn (Clockwise) both Bolts one half a turn again.

Free area and training area

The free area should be no less than 0.6m greater than the training area in the directions from which the equipment is accessed. The free area must also include the area for emergency dismount. Where equipment is positioned adjacent to each other the value of the free area may be shared.

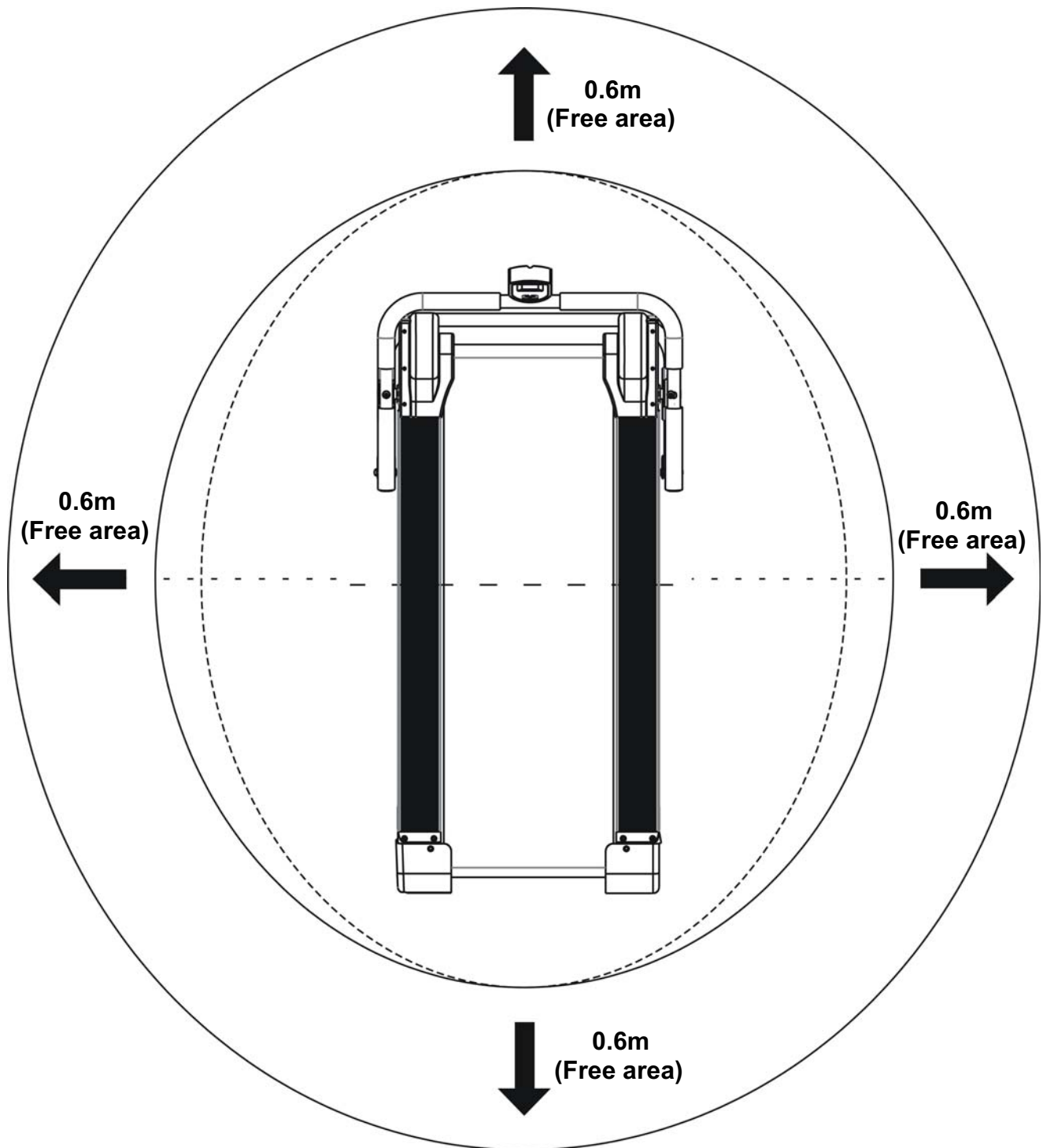

Computer Operation



Functions and operations

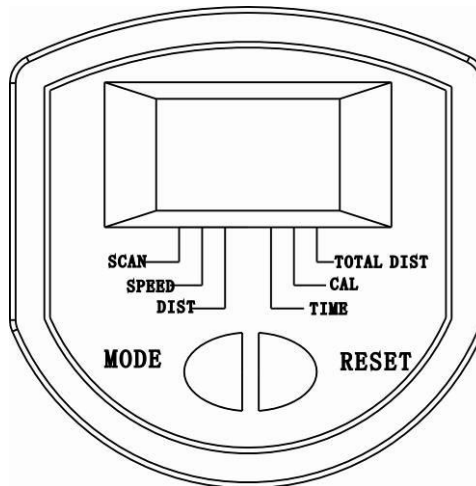

Exercise Monitor Functions and Specification:

- ✧ **SPEED** -- Display the current running speed
- ✧ **DISTANCE** – Display the current running distance
- ✧ **TOTAL DISTANCE**—Display different exercise section total running distance
- ✧ **CALORIE** --- Computed Theoretical Calorie Burn
- ✧ **TIME**— Display total workout time (Minutes and Seconds)

Specification

Function	Auto Scan	Every 4 Seconds
	Total Distance	0.0 – 999.9 Km or Mile (According to inside setting)
	Calories	0.0 – 999.9 Kcal
	Step Count	0.0 – 999.9 Km or Mile (According to inside setting)
	Time	0;00 – 99.59 (Minute: Second)
Sensor	No – Contact magnetic type	
Battery type	2x AA (1.5V) Batteries	
Operation Temperature	0°C - +40°C	

USING YOUR EXERCISE MONITOR

- ✧ Press the **MODE** Button to manually move through each of the Exercise Monitor's Function in turn. These are: **Scan/ Speed / Distance /Total Distance/ Calorie /Time.**
- ✧ If you press the **MODE** button until you reach the **Scan** mode, the display will change approximately **EVERY 4- SECONDS** to show each function in turn.
- ✧ Pressing and holding the **RESET** button will enable you to set to zero all figures remaining in every individual function.
- ✧ Start to exercise and the Exercise Monitor will begin to register the various functions. The monitor will shut down after approximately 4 Minutes of inactivity to save power.

Computer Operation

Replacement of the batteries

1. Remove the battery cover on the back of the computer.
2. Replace two AA batteries (See picture B and C
3. Make sure the batteries are installed correctly and the polarities are correct.
4. If the display is not clear or only partial segments appeared, remove the batteries and wait for 15 seconds before re-installing them.
5. The battery life is approx. 3 months under normal usage.
6. When the batteries are removed, all the functional values will reset to zero.

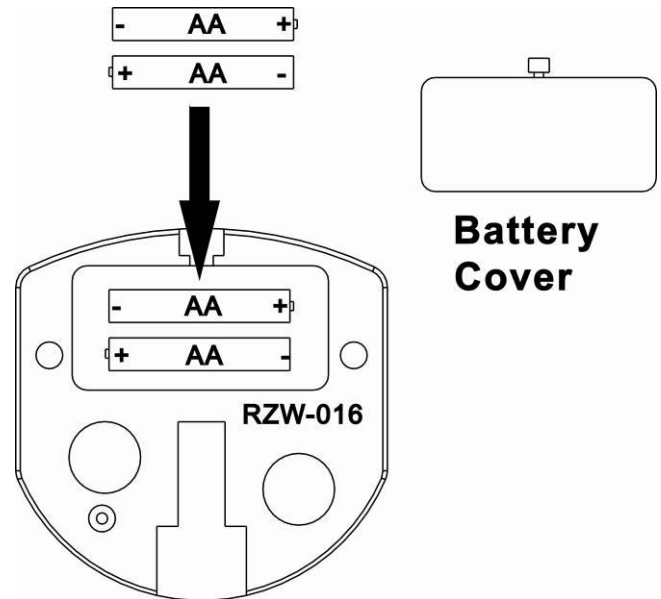

Exercise Information



Before starting to exercise

How you begin your exercise program depends on your physical condition. If you have been inactive for several years, or are severely overweight, you must start slowly and increase your time on the equipment; a few minutes per workout.

Initially, you may be able to exercise only for a few minutes in your target zone, however, your aerobic fitness will improve over the next six to eight weeks. Don't be discouraged if it takes longer. It's important to work at your own pace. Ultimately, you'll be able to exercise continuously for 30 minutes. The better your aerobic fitness, the harder you will have to work to stay in your target zone.

Please remember these essentials:

- Have your doctor review your training and diet programs to advise you of a workout routine you should adopt.
- Begin your training program slowly with realistic goals that have been set by you and your doctor.
- Monitor your pulse frequently. Establish your target heart rate based on your age and condition.
- Set up your equipment on a flat even surface at least 3 feet from walls and furniture.

Exercise intensity

To maximize the benefits of exercising, it is important to exercise with the proper intensity. The proper intensity level can be found by using your heart rate as a guide. For effective aerobic exercise, your heart rate should be maintained at a level between 65% and 85% of your maximum heart rate as you exercise. This is known as your target zone. You can find your target zone in the table below.

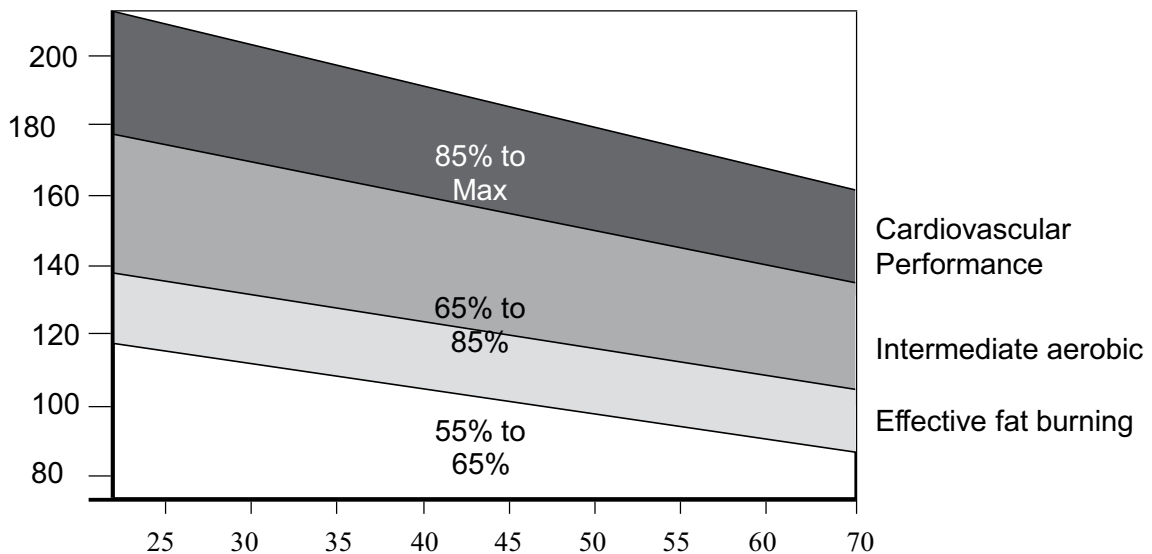

During the first few months of your exercise program, keep your heart rate near the low end of your target zone as you exercise. After a few months, your heart rate can be increased gradually until it is near the middle of your target zone as you exercise.

To measure your heart rate, stop exercising but continue moving your legs or walking around and place two fingers on your wrist. Take a six-second heartbeat count and multiply the results by 10 to find your heart rate. For example, if your six-second heartbeat count is 14, your heart rate is 140 beats per minute.

(A six-second count is used because your heart rate will drop rapidly when you stop exercising.) Adjust the intensity of your exercise until your heart rate is at the proper level.

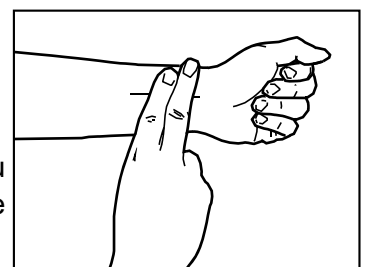

Exercise Information

Muscle Chart

Aerobic Exercise

Aerobic exercise improves the fitness of your lungs and heart - your body's most important muscle. Aerobic exercise fitness is promoted by any activity that uses your large muscles (arms, legs, or buttock, for example). Your heart beats quickly and you breathe deeply. An aerobic exercise should be part of your entire exercise routine.

Weight Training

Along with aerobic exercising which helps get rid of and keep off the excess fat that our bodies can store, weight training is an essential part of the exercise routine process. Weight training helps tone, build and strengthen muscle. If you are working above your target zone, you may want to do a lesser amount of reps. As always, consult your doctor before beginning any exercise program.

Targeted Muscle Groups

The exercise routine that is performed on the Cycle/Cross Trainer will develop the upper and lower body muscle groups. These muscle groups are highlighted on the muscle chart below.

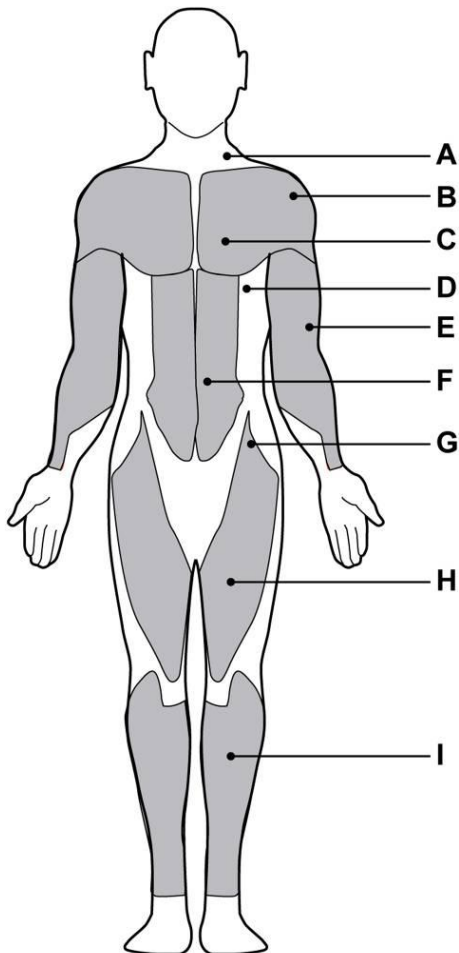

Front

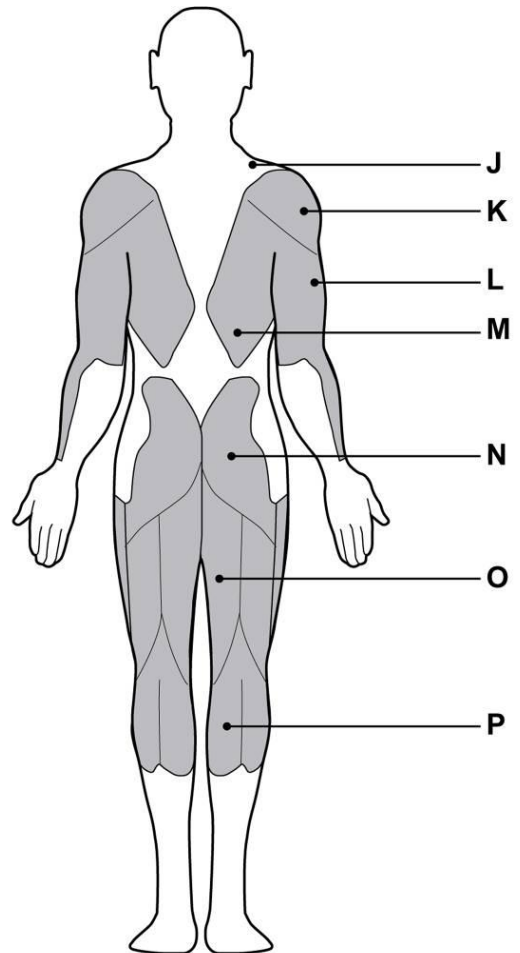

Back

- | | |
|-----------------------------|----------------------|
| A: Trapezius | F: Abdominal |
| B: Anterior | G: Sartorius |
| C: Pectoralis Major | H: Quadriceps |
| D: Serratus Anterior | I: Tibialis |
| E: Biceps | |

- | | |
|----------------------------|-------------------------|
| J: Trapezius | N: Gluteals |
| K: Posterior | O: Hamstrings |
| L: Triceps | P: Gastrocnemius |
| M: Latissimus Dorsi | |

Exercise Information



Warming up and Cooling down exercise

Each workout should include the following three parts:

1. A warm-up, consisting of 5 to 10 minutes of stretching and light exercise. A proper warm-up increases your body temperature, heart rate, and circulation in preparation for exercise.
2. Training zone exercise, consisting of 20 to 30 minutes of exercising with your heart rate in your training zone. (**Note:** During the first few weeks of your exercise program, do not keep your heart rate in your training zone for longer than 20 minutes.)
3. A cool-down, with 5 to 10 minutes of stretching. This will increase the flexibility of your muscles and will help to prevent post-exercise problems.

Exercise Frequency

To maintain or improve your condition, plan three workouts each week, with at least one day of rest between workouts. After a few months of regular exercise, you may complete up to five workouts each week, if desired. Remember, the key to success is make exercise a regular and enjoyable part of your everyday life.

Toe touch stretch

Stand with your knees bent slightly and slowly bend forward from your hips. Allow your back and shoulders to relax as you reach down toward your toes as far as possible.

Hold for 15 counts, then relax. Repeat 3 times.

Stretches: Hamstrings, back of knees and back.



Hamstring stretch

Sit with one leg extended. Bring the sole of the opposite foot toward you and rest it against the inner thigh of your extended leg. Reach toward your toes as far as possible.

Hold for 15 counts, then relax. Repeat 3 times for each leg.

Stretches: Hamstrings, lower back and groin.

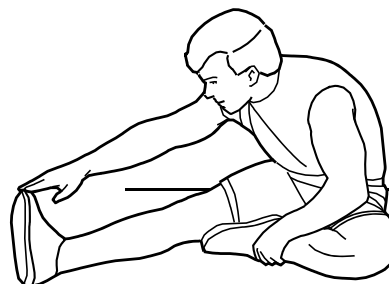

Exercise Information

Calf/Achilles stretch

With one leg in front of the other, reach forward and place your hands against a wall. Keep your back leg straight and your back foot flat on the floor. Bend your front leg, lean forward and move your hips toward the wall.

Hold for 15 counts, then relax.

Repeat 3 times for each leg. To cause further stretching of the Achilles tendons, bend your back leg as well.

Stretches: Calves, Achilles tendons and ankles.

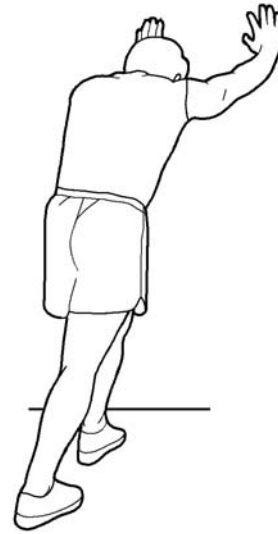

Quadriceps stretch

With one hand against the wall for balance, reach back and grasp one foot with your other hand. Keeping your bent knee pointing directly downward towards the floor, gently pull your heel towards your buttock until you feel a gentle stretch in the target area.

Hold for 15 counts, then relax. Repeat 3 times for each leg.

Stretches: Quadriceps and hip muscles.



Inner thigh stretch

Sit with the soles of your feet together and your knees outward. Pull your feet toward your groin area as far as possible.

Hold for 15 counts, then relax. Repeat 3 times.

Stretches: Quadriceps and hip muscles.



Care and Maintenance

1. Examine the equipment periodically in order to detect any damage or wear which may have been produced.
2. Lubricate moving parts with light oil periodically to prevent premature wear.
3. Inspect and tighten all parts before using the equipment, replace any defective parts immediately, and do not use

- the equipment again until it is in perfect working order.
4. The equipment can be cleaned using a damp cloth and mild non-abrasive detergent. **Do not** use solvents.
 5. **Do not** attempt to repair this equipment yourself. Should you have any difficulty with assembly, operation or

Use of your exercise product or if you think that you may have parts missing, contact the manufacturer, their approved service agent or the Customer Helpline: 0345 6001714.
Guarantee:
For guarantee purposes, please retain your purchase receipt.

Information for Users on Disposal of old Equipment and Batteries (European Union only)

These symbols indicate that equipment with these symbols should not be disposed of as general household waste. If you want to dispose of the product or battery, please consider the collection systems or facilities for appropriate recycling.

Notice: The sign Pb below the symbol for batteries indicates that this battery contains lead.



Exploded Parts Diagram

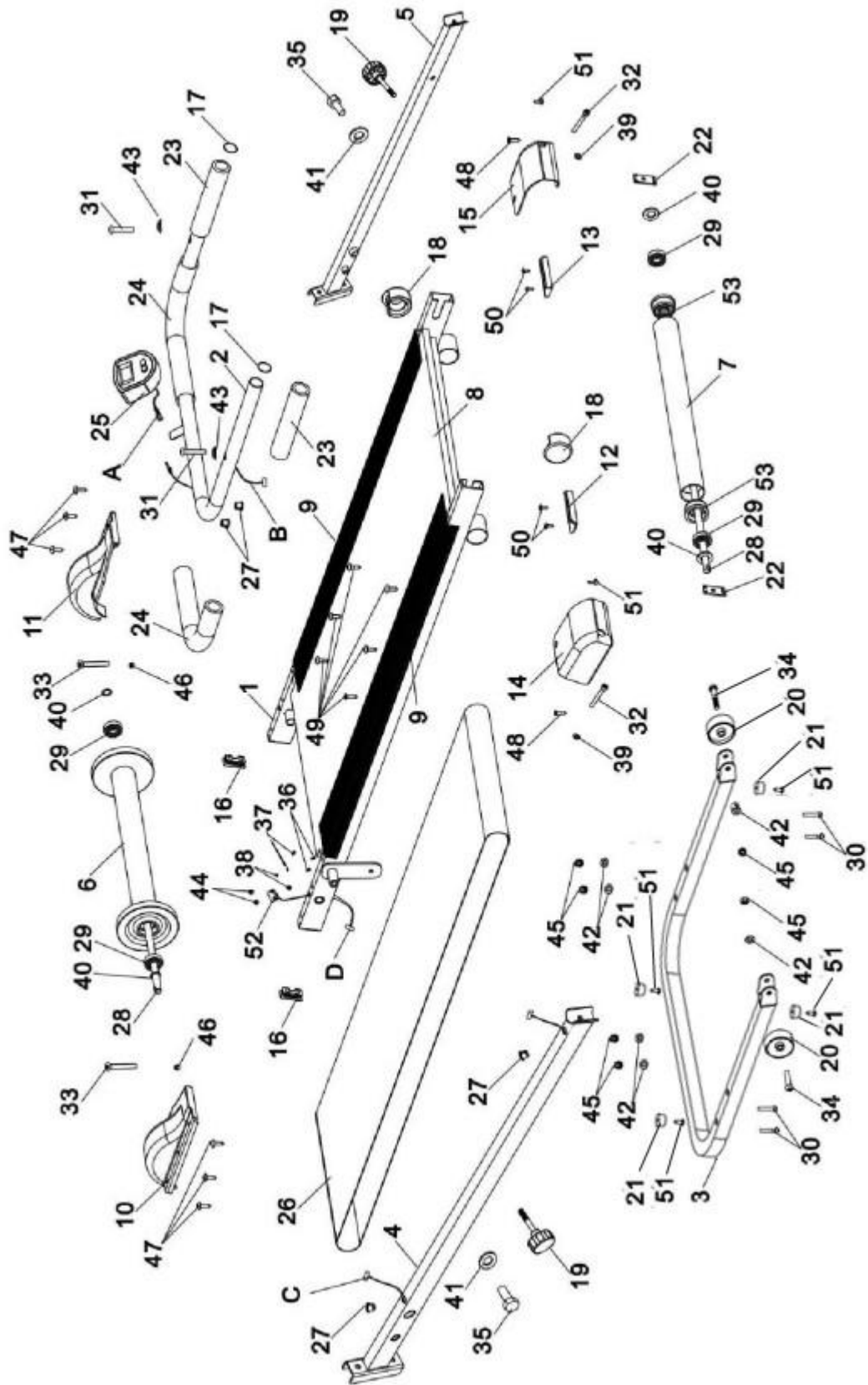

Exploded Parts List

Part #	Description	QTY	Part #	Description	QTY
1	Main Frame	1	30	M8×40mm Carriage Bolt	4
2	Handlebar	1	31	M8×40mm Allen Bolt	2
3	Base Frame	1	32	M6×50mm Allen Bolt	2
4	Left Console Mast	1	33	M6×45mm Allen Bolt	2
5	Right Console Mast	1	34	M8×45 Hex Bolt	2
6	Front Roller	1	35	M10×20mm Hex Bolt	2
7	Rear Roller	1	36	M3×12mm Philips Bolt	2
8	Running Deck	1	37	Φ3 Spring WasherØ	2
9	Side Rail	2	38	Φ3 Washer	2
10	Left Frame Cap	1	39	Φ 6 Washer	2
11	Right Frame Cap	1	40	φ12 Washer	4
12	Left End Cap Block Bracket	1	41	Φ 10 Big Washer	2
13	Right End Cap Block Bracket	1	42	Φ 8 Washer	6
14	Left End Cap	1	43	Φ 8 Arc Washer	2
15	Right End Cap	1	44	M3 Nut	2
16	20×40×1.5 End Cap	2	45	M8 Aircraft Nut	6
17	φ25×1.5 End Cap	2	46	M6 Aircraft Nut	2
18	Level Foot	2	47	ST4.8×25 Dome Head Philips Screw	6
19	M8×55 Knob	2	48	ST4.8×15 Philips Screw	2
20	Wheel	2	49	ST4.8×25 Philips Screw	6
21	Shock Pad	4	50	ST4.8×15 Dome Head Philips Screw	4
22	End Cap Guide Bracket	2	51	ST4.8×15 Dome Head Philips Screw	6
23	Foam Grip	2	52	Sensor Bracket	1
24	Foam Grip	2	53	Bearing Housing	2
25	Computer	1	A		1
26	Running Belt	1	B		1
27	Computer Wire Clamp	4	C		1
28	φ12 Axle	2	D		1
29	Bearing	4			

Guarantee



Product Guarantee

This product is guaranteed against manufacturing defects from a period of



YEAR

This product is guaranteed against for one years from the date of original purchase Any defect that arises due to faulty materials or workmanship will either be replaced refunded or repaired free of charge where possible during this period by the dealer from whom you purchased the unit.

The guarantee is subject to the following provisions:

- The guarantee does not cover accidental damage, misuse, cabinet parts, knobs or consumable items.
- The product must be correctly installed and operated in accordance with the instructions contained in this manual
- It must be used solely for domestic purpose
- The guarantee will rendered invalided if the products is re-sold or has been damaged by inexpert repair
- Specifications are subject to change without notice
- The manufacturer disclaim any liability for the incidental or consequential damages.
- The guarantee is in addition to, and does not diminish your statutory or legal right
- In the event of problem with the product with in the guarantee period call the

Customer Helpline: 0345 6001714

<http://www.argos-support.co.uk>

Guarantor: Argos Ltd
489 – 499 Avebury Boulevard
Central Milton Keynes
MK9 2NW