

Natural Finish Wood & Glass Tel Table

Assembly Instructions - Please keep for future reference

609/3114

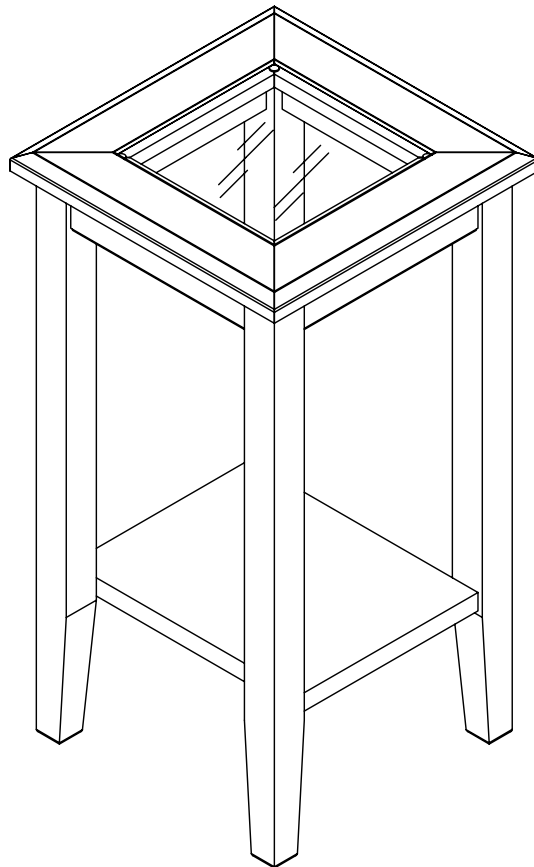

Dimensions

Width - 30cm
Depth - 30cm
Height - 57cm

Important - Please read these instructions fully before starting assembly

If you need help or have damaged or missing parts, call the **Customer Helpline: 08456 400800.**

Components - Panels

If you have damaged or missing componets, call the **Customer Helpline:08456 400800.**

Please check you have all the panels listed below

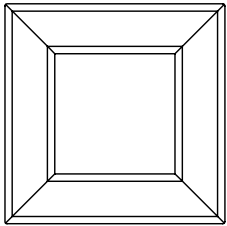

1 Top (30 × 30cm)



2 Leg × 2 (55.2 × 3.4cm)



3 Leg × 2 (55.2 × 3.4cm)

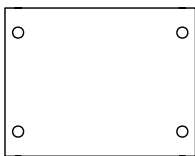

6 Bottom (26 × 20.2cm)

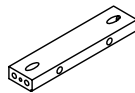

5 Support rail × 2
(20.2 × 4.5cm)

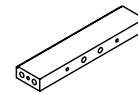

4 Support rail × 2
(20.2 × 4.5cm)

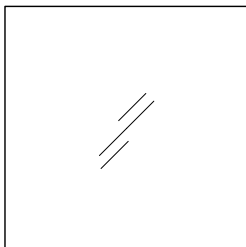





7 Glass (18.2 × 18.2cm)

Components - Fittings

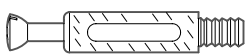
Please check you have all the fittings listed below

Note: The quantities below are the correct amount to complete the assembly. In some cases more fittings may be supplied than are required.

A  Wooden dowel × 20	B  Locking pin × 4	C  Locking nut × 4
D  Ø3.5×40mm Screw × 8	E  Ø5×30mm Screw × 8	F  Pad × 4

Tools required

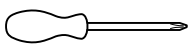

Phillips screwdriver
(medium & large)



Small
hammer

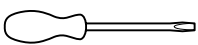

Flatblade screwdriver
(medium)

Ruler - Use this ruler to help correctly identify the screws

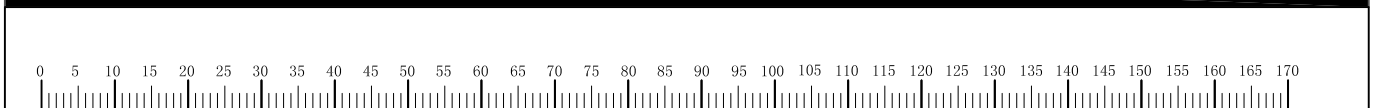

Assembly Instructions

Step 1

Fitting dowels

a: Insert Locking pin **B** into Leg **2** and Leg **3**.

Note: Insert Locking pin as far as shown.

Do not over tighten.

b: Insert 6 Wooden dowels **A** into Support rail **4**.

Insert 4 wooden dowels **A** into Support rail **5**.

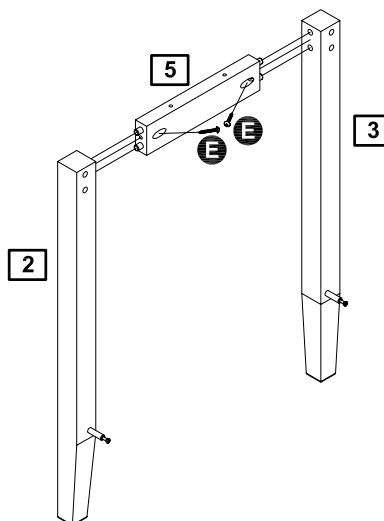
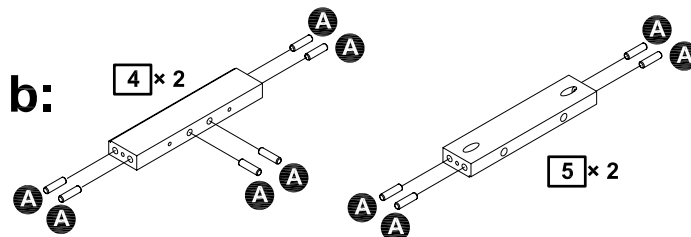
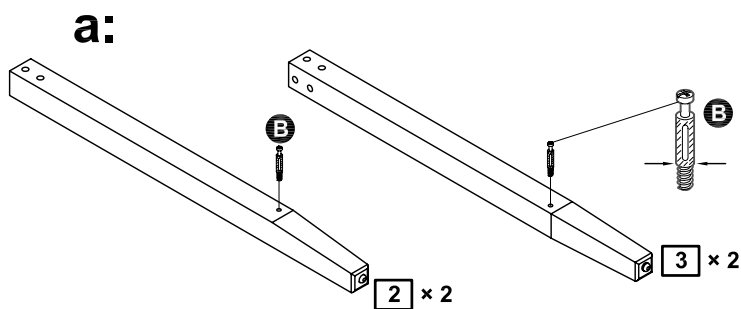

Step 2

Side frames assembly

Fix Support rail **5** onto Leg **2** and Leg **3** by using 2 Screw **E**.

Repeat with another Side frame.

Step 3

Attaching side frames

a: Position Bottom **6** and Support rails **4** onto Side frames.

b: Insert 4 Locking nuts **C** into Bottom **6**.

Use a screwdriver to turn locking nuts **C** clockwise to lock.

c: Fix Support rails **4** by using 4 Screws **E**.

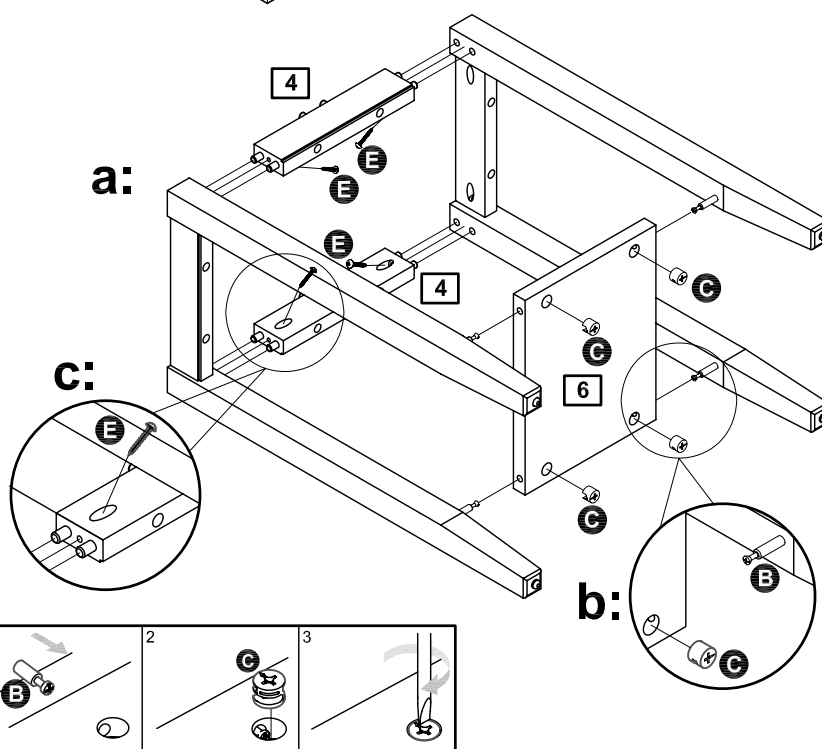

Assembly Instructions

Step 4

Attaching top

Fix Top **1** onto the assembly by using 8 screws **D**.

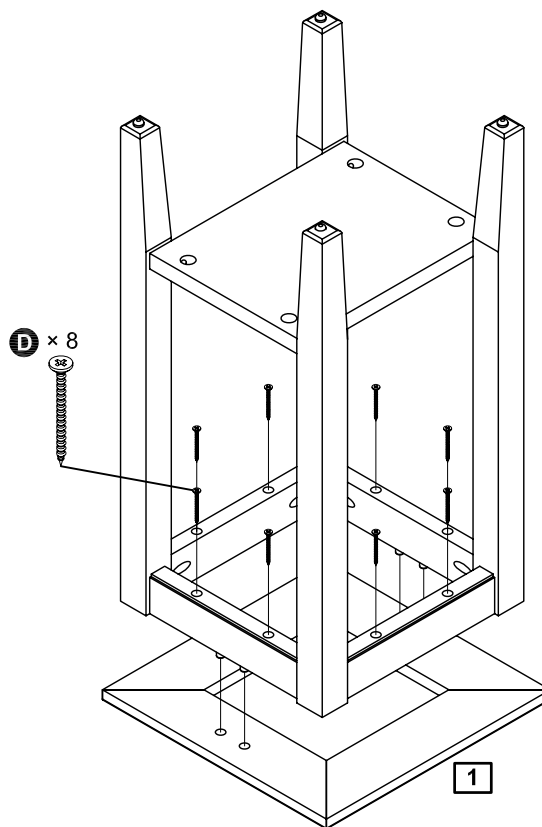

Step 5

Positioning glass

Put 4 Pads **F** onto the corners of the assembly top.

Carefully put glass **7** onto the assembly.

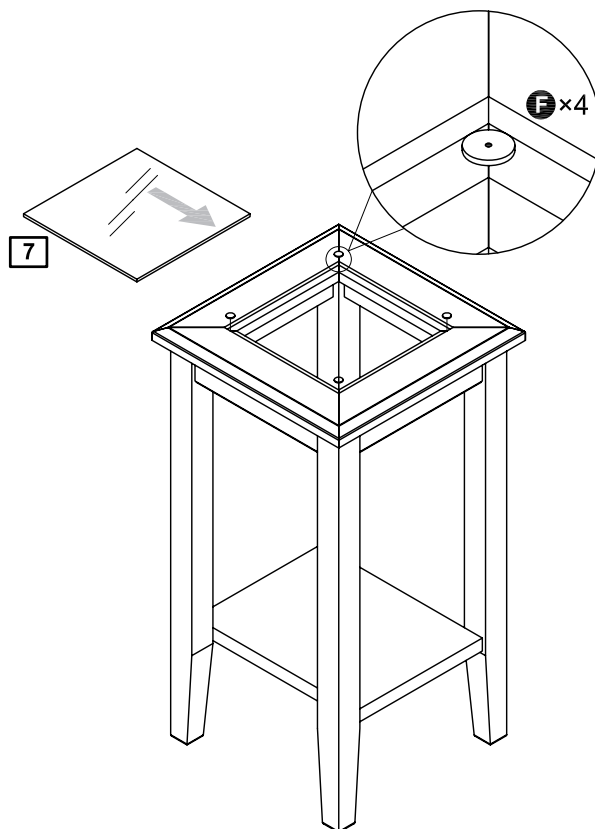

Assembly is complete.

If you need help or have damaged or missing parts, call the **Customer Helpline: 08456 400800.**