

Components

Ⓐ 1 x Table Top

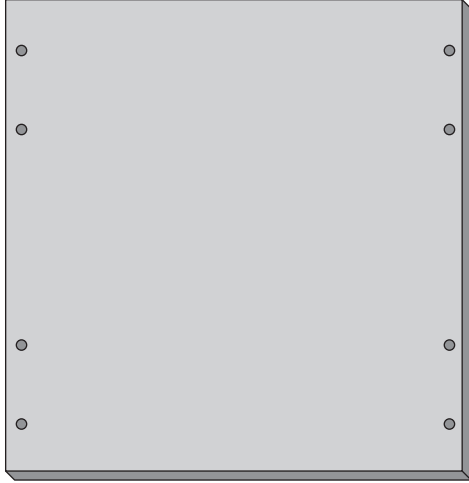

Ⓑ 1 x Table Bottom

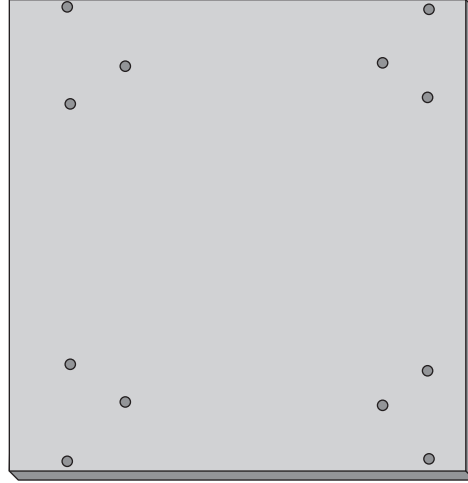

Ⓒ 2 x Base End Panel



Ⓔ 2 x Base Side Panel

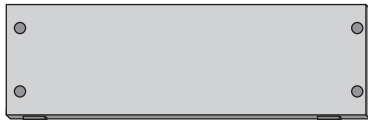

Ⓓ 2 x Table Side Panel



Cubes End Table

Simple Assembly Instructions - Please keep for future reference

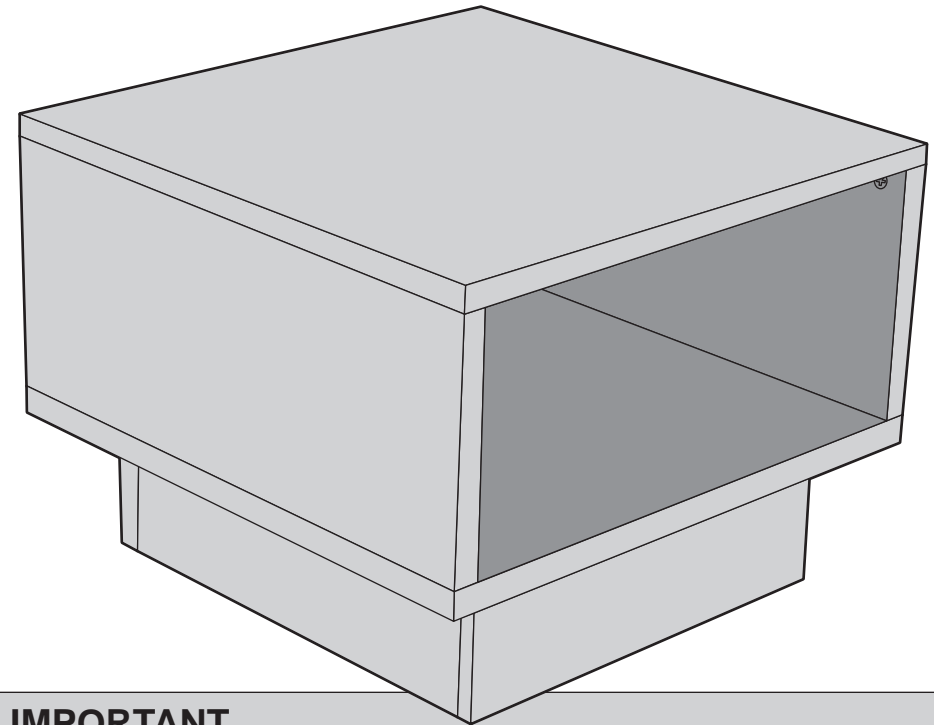

IMPORTANT

Fittings

Ⓐ 4 x Screw



Ⓑ 24 x Dowel



Ⓒ 4 x Locking Pin



Ⓓ 4 x Locking Nut



Ⓔ 1 x Glue

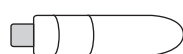

1. Read these instructions carefully and familiarise yourself with the procedure before assembling the unit.

2. Check that you have all the component parts following the list on the back cover and familiarise yourself with each part before proceeding.

3. Take all the fittings out of the plastic bag and separate them into their groups.

4. Ensure you have enough space to lay out all the parts before assembly.

5. To avoid scratching it is recommended that you assemble the unit on a soft level surface.

Assembly Instructions

Stage 1 – Fitting the Base

 **CAUTION:** Always check the assembly method is correct before applying glue.

NOTE: It would be useful to ask someone to help you at this stage.

1. Place a small amount of Glue **E** into the dowel holes. Insert Dowels **B** into the Base End Panels **C**. See fig. 1.

NOTE: Ensure the top fixing holes are aligned and face upwards on the side panels before assembly.

2. Place a small amount of Glue **E** into the dowel holes and onto the joints surfaces. Fix the Base End Panels **C** onto the Base Side Panels **E**. See fig. 2.

3. Place a small amount of Glue **E** into the dowel holes and onto the joints surfaces. Use Dowels **B** to fix the Table Bottom **B** onto the unit. See fig. 3.

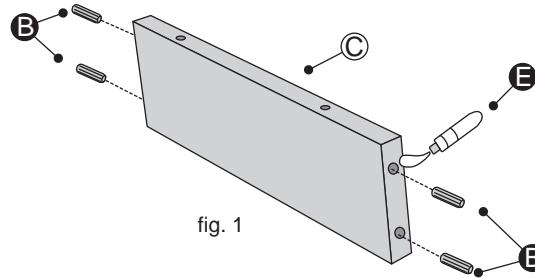

fig. 1

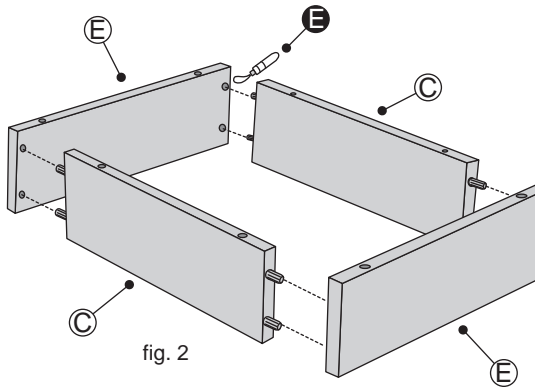

fig. 2

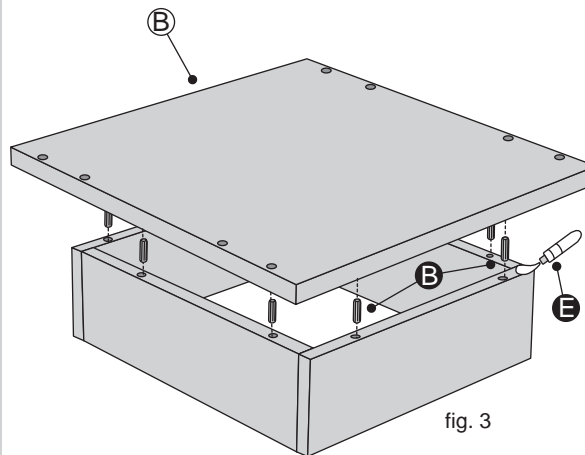



fig. 3

Assembly Instructions

Stage 2 – Fitting the Side Panels

 **CAUTION:** Always check the assembly method is correct before applying glue.

NOTE: It would be useful to ask someone to help you at this stage.

1. Place a small amount of Glue **E** into the dowel holes. Insert Dowels **B** into the Table Side Panels **D**. See fig. 4.

2. Place a small amount of Glue **E** into the dowel holes and onto the joints surfaces. Fix the Table Side Panels **D** onto the unit. See fig. 5.

NOTE: Ensure the screw holes on the Side Panels are facing inwards.

3. Use Screws **A** to fix the Table Side Panels **D** onto the unit. See fig. 6.

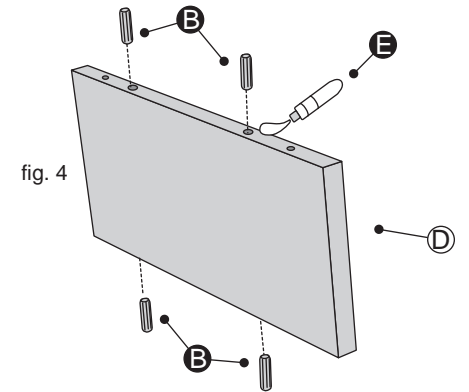

fig. 4

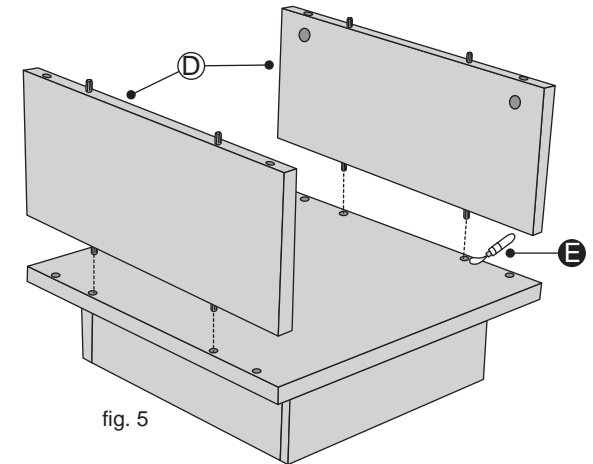

fig. 5

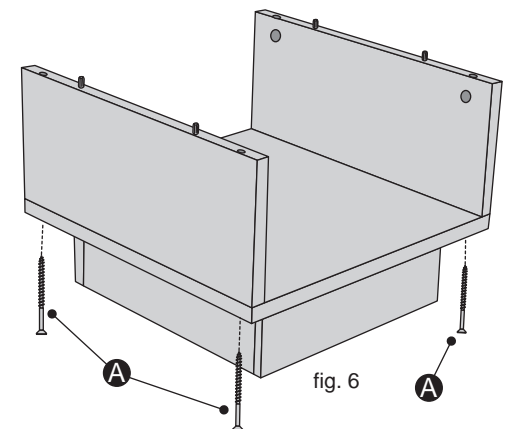



fig. 6

Assembly Instructions

Stage 3 – Fitting the Table Top

 **CAUTION:** Always check the assembly method is correct before applying glue.

NOTE: It would be useful to ask someone to help you at this stage.

1. Screw in Locking Pins **C** into the Table Top **A**.
See fig. 7.

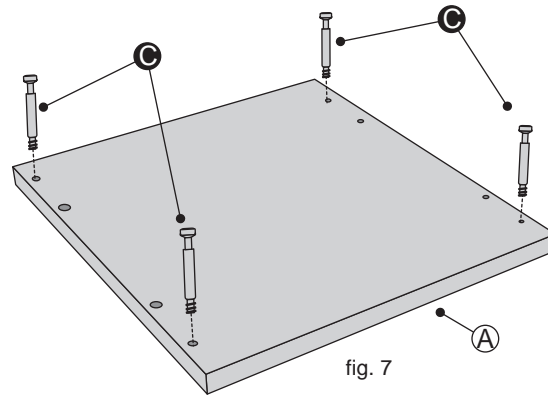

2. Place a small amount of Glue **E** into the dowel holes and onto the joints surfaces. Carefully locate the Table Top **A** onto the unit.
See fig. 8.

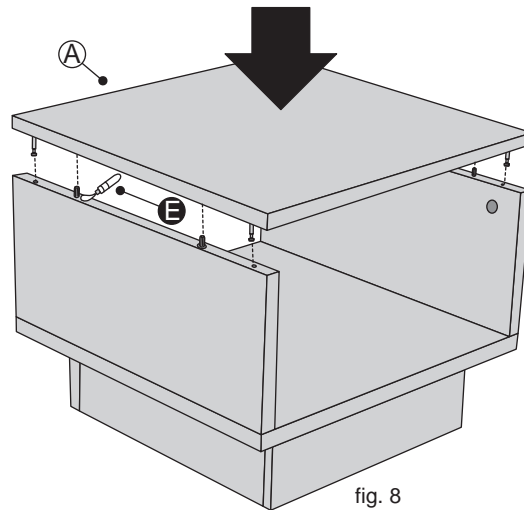

Assembly Instructions

Stage 4 – Finishing the Unit

NOTE: It would be useful to ask someone to help you at this stage.

1. Use Locking Nuts **D** to fix the Table Top **A** onto the unit.
See fig. 9.

2. Carefully place the unit in the desired location.
See fig. 10.

NOTE: Before use make sure the unit is secure. Allow glue to dry for 24 hours before use.

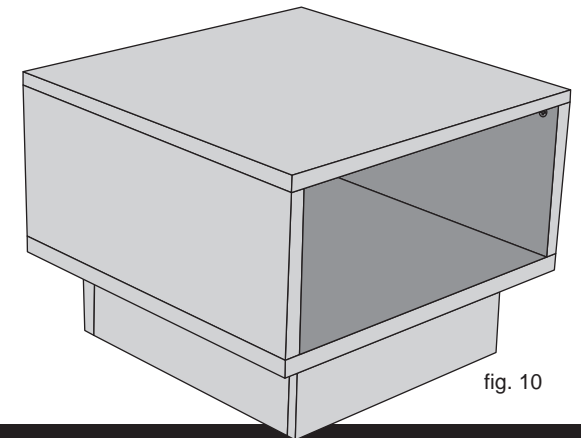
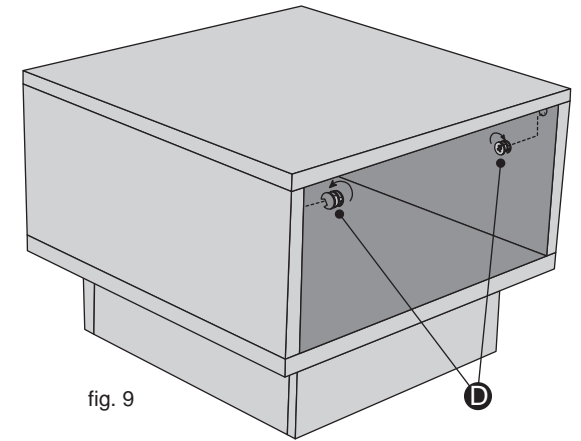

Care and Maintenance

Safety

To avoid any risk of suffocation to animals or children dispose of the plastic bags immediately.

Cleaning

As with all surfaces clean with a damp cloth and mild detergent, do not use bleach or abrasive products.

Fitting

From time to time please ensure there are no loose screws on the product.