

HM 6 TIER EXTENDABLE SHOE RACK CHROME

Assembly Instructions - Please keep for future reference

607/7446

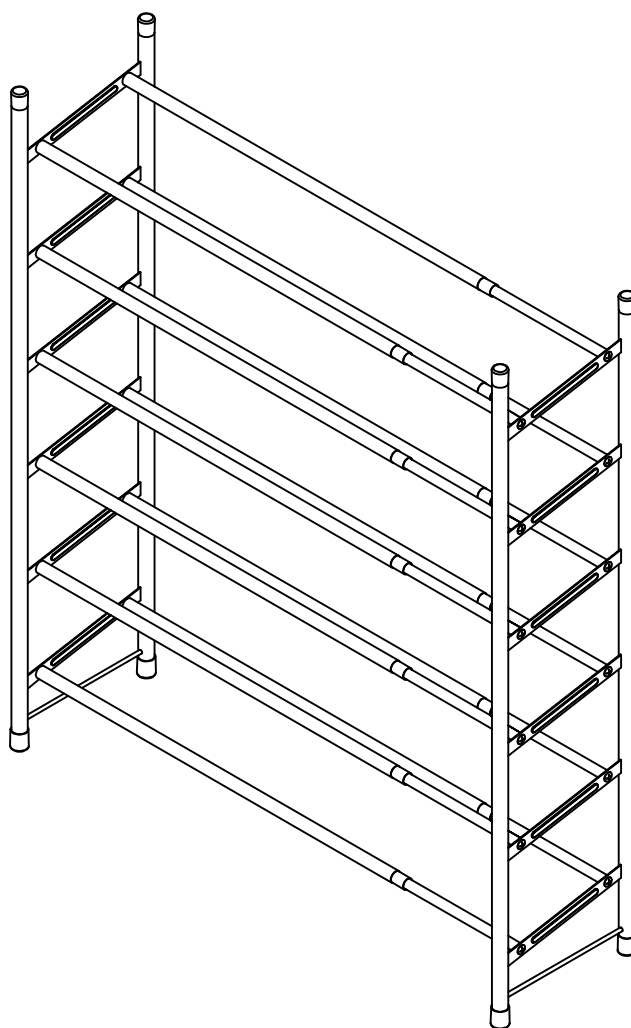

Dimensions

Width - 62.5-118.5cm

Depth - 22.5cm

Height - 78-100cm

Important – Please read these instructions fully before starting assembly

If you need help or have damaged or missing parts, call the **Customer Helpline: 03456 400800**



Safety and Care Advice

Important – Please read these instructions fully before starting assembly

- Check you have all the components and tools listed on the following pages.
- Remove all fittings from the plastic bags and separate them into their groups.
- Keep children and animals away from the work area, small parts could choke if swallowed.
- Make sure you have enough space to layout the parts before starting.

- During assembly do not stand or put weight on the product, this could cause damage.
- Assemble the item as close to its final position (in the same room) as possible.
- Assemble on a soft level surface to avoid damaging the unit or your floor.
- Parts of the assembly will be easier with 2 people.



- To reduce the likelihood of damaging your product please ensure that your power drill is set on a low torque setting.

Care and maintenance

- Only clean using a damp cloth and mild detergent, do not use bleach or abrasive cleaners.
- From time to time check that there are no loose screws on this unit.
- This product should not be discarded with household waste. Take to your local authority waste disposal centre.

Handy Hints

- Assemble all parts and bolts loosely during assembly, only once the product is complete should you fully tighten the bolts
- Regularly check and ensure that all bolts and fittings are tightened properly.

Note: If required the next page can be cut out and used as reference throughout the assembly. Keep this page with these instructions for future reference.

Components - Parts

If you have damaged or missing components, call the **Customer Helpline: 03456 400800**

Please check you have all the fittings listed below

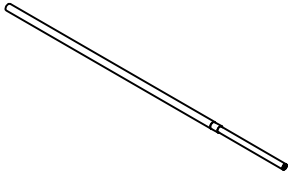

1 Steel Tube x 12

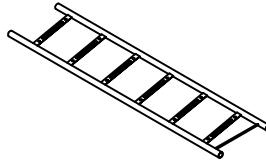

2 Side Frame x 2

Components - Fittings

Please check you have all the fittings listed below

Note: The quantities below are the correct amount to complete the assembly. In some cases more fittings may be supplied than are required.

A



Screw x 24

B



Rubber End Cap x 8

Tools required

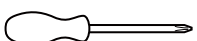

Screwdriver

Assembly Instructions

Step 1

Assemble the Unit

1. Connect Steel Tube **1** with Side Frame **2** together using Screw **A**.
2. Insert End Cap **B** to Top and Bottom Side Frame **2**.

see fig.1

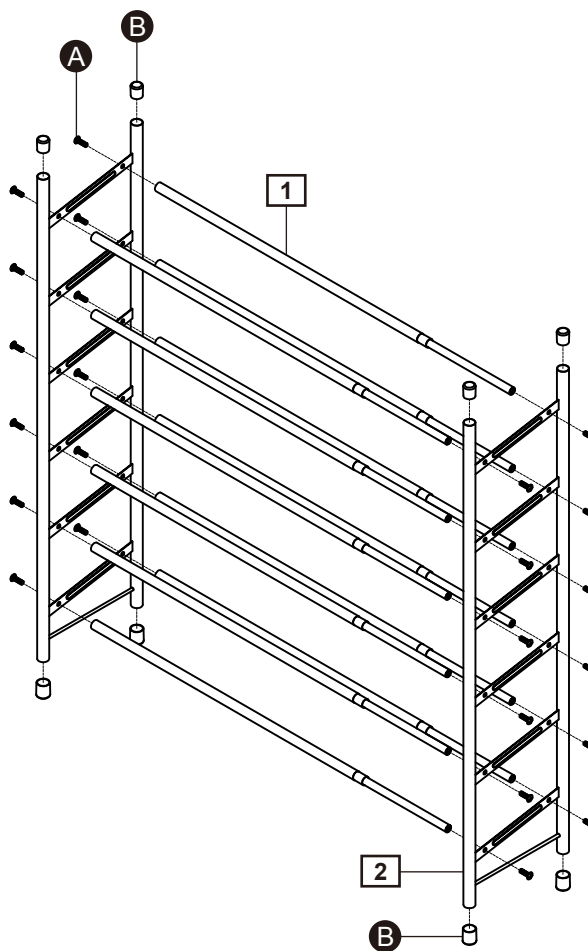

fig. 1

Step 2

The unit is complete

see fig.2

Important Note:

The maximum load for each tier is 4 kg. Please do not put any heavier object than 4 kg on each tier.

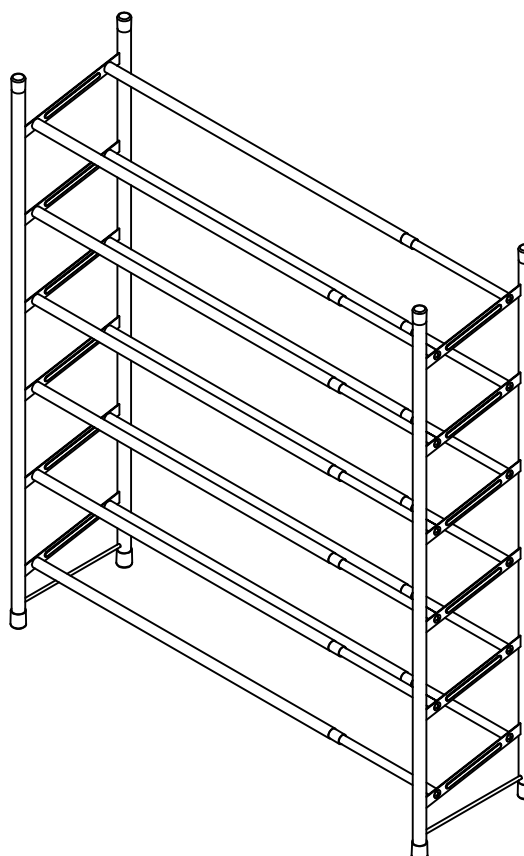

fig. 2