



ASSEMBLY INSTRUCTIONS

Pour le français, voir la page 2. Para el español, ver la página 3.

7' x 4.5' OUTDOOR STORAGE SHED

MODEL 60057

BEFORE ASSEMBLY:

- Assemble on a level surface.
- At least 3 people recommended for setup.



WATCH THE HOW-TO ON YOUTUBE



Scan the code, or visit go.lifetime.com/60057playlist

YouTube® and the YouTube logo are trademarks of Google, LLC.

FOR DOMESTIC USE ONLY! IMPORTANT, RETAIN FOR FUTURE REFERENCE: READ CAREFULLY.

TOOLS REQUIRED

(Not included—unless otherwise indicated*)



TABLE OF CONTENTS

Icon legend.....	4
Warnings & notices.....	5
Platform construction.....	6
Truss assembly.....	11
Gable assembly.....	15
Door assembly.....	18
Floor assembly.....	29
Wall assembly.....	33
Shelving installation.....	43
Door & gable installation.....	46
Parts identifier.....	i-iv
Roof assembly.....	52
Door alignment.....	69
Shed anchoring.....	72
Latch installation.....	75
Cleaning & care.....	87
Registration.....	88
Warranty.....	89

QUESTIONS?

Call:
1-800-225-3865
(English, French, Spanish)

CONTACT LIFETIME CUSTOMER SERVICE:

Live Chat:
www.lifetime.com/customerservice/home
(click on "LIVE CHAT" tab)

For Customer Service in mainland Europe
and the United Kingdom, E-mail:
csinternational@lifetime.com

Model: **60057**
Product ID:



INSTRUCTIONS D'ASSEMBLAGE

For English, see page 1. Para el español, ver la página 3.

ABRI EXTÉRIEUR DE 2,13 m x 1,4 m

MODÈLE n° 60057

AVANT L'ASSEMBLAGE :

- Assembler sur une surface de niveau.
- Nous recommandons, au moins, 3 adultes pour l'assemblage.



REGARDER LA VIDÉO SUR YOUTUBE



Scanner le code, ou visiter go.lifetime.com/60057playlist

YouTube® et le logotype YouTube sont des marques déposées de Google, LLC.

POUR L'USAGE DOMESTIQUE SEULEMENT ! IMPORTANT, CONSERVER POUR RÉFÉRENCE : LIRE ATTENTIVEMENT !

OUTILS REQUIS

(Non inclus — sauf indication contraire*)



SOMMAIRE

Légende des icônes.....	4
Avertissements et avis.....	5
Assemblage de la plate-forme.....	6
Assemblage des fermes.....	11
Assemblage des pignons.....	15
Assemblage des portes.....	18
Assemblage du plancher.....	29
Assemblage des murs.....	33
Installation du rayonnage.....	43
Installation des portes.....	46
Identificateur de pièces.....	i-iv
Assemblage du toit.....	52
Alignement des portes.....	69
L'ancrage de l'abri.....	72
Installation de loquet.....	75
Nettoyage et entretien.....	87
Enregistrement.....	88
Garantie.....	90

QUESTIONS ?

Composer le
1-800-225-3865
(anglais, français, espagnol)

CONTACTER LIFETIME® :

Entretien en direct:
www.lifetime.com/customerservice/home
(cliquer sur la languette « LIVE CHAT »)

Pour les services à la clientèle du
continent européen, é-mail:
csinternational@lifetime.com

Modèle : 60057
Référence du produit :



INSTRUCCIONES DE ENSAMBLAJE

For English, see page 1. Pour le français, voir la page 2.

CASETA EXTERIOR DE 2,13 m x 1,4 m

MODELO n° 60057

ANTES DE ENSAMBLAR:

- Ensamblar sobre una superficie nivelada.
- Recomendamos, al menos, 3 adultos para el ensamblaje.

MIRAR EL VIDEO EN YOUTUBE



Escanear el código, o visitar go.lifetime.com/60057playlist

YouTube® y el logotipo YouTube son marcas registradas de Google, LLC.



¡SÓLO PARA USO DOMÉSTICO! ¡IMPORTANTE, GUARDAR PARA FUTURA REFERENCIA: LEER CUIDADOSAMENTE!

INSTRUMENTAL REQUERIDO

(No incluido, salvo indicación contraria*)



ÍNDICE

Leyenda de íconos.....	4
Advertencias y avisos.....	5
Ensamblaje de la plataforma.....	6
Ensamblaje de las cerchas.....	11
Ensamblaje de las fachadas.....	15
Ensamblaje de las puertas.....	18
Ensamblaje del piso.....	29
Ensamblaje de los muros.....	33
Instalación de la estantería.....	43
Instalación de las puertas.....	46
Identificador de piezas.....	i-iv
Ensamblaje del tejado.....	52
Alineación de la puertas.....	69
Anclaje de la caseta.....	72
Instalación del pestillo.....	75
Limpieza y cuidado.....	87
Registro.....	88
Garantía.....	91

¿PREGUNTAS?

PONERSE EN CONTACTO CON LOS SERVICIOS DE CLIENTES LIFETIME®:

Llamar:
1-800-225-3865
(inglés, francés, español)

Chat en vivo:
www.lifetime.com/customerservice/home
(clicar en la lengüeta «LIVE CHAT»)

Para el servicio a clientes en el
continente europeo, correo electrónico:
csinternational@lifetime.com

Modelo: 60057
ID del producto:



ICON LEGEND / LÉGENDE DES ICÔNES / LEYENDA DE ÍCONOS



- Indicates special heed should be taken when reading.
- Indique qu'une attention spéciale doit être portée à la lecture.
- Indica que uno debe prestar atención al leer.



- Indicates the parts (or no parts) required for a section.
- Indique les pièces (ou aucune pièce) à utiliser pour une section.
- Indica las piezas (o ninguna pieza) que se usarán en una sección.



- Indicates the hardware (no new hardware) required for a specific page or section.
- Indique la quincaillerie (ou aucune nouvelle quincaillerie) n'est requis pour une page précise.
- Indica el herraje (que no se necesita nuevo herraje) para una página específica.



- Indicates the tools (or no tools) to be used for a section.
- Indique les outils (ou aucun outil) à utiliser pour une section.
- Indica las herramientas (o ninguna herramienta) que se utilizarán para una sección.



- Indicates to use/not use an electric drill for a specific step.
- Indique quand utiliser une/que ne pas utiliser de perceuse électrique pour une étape précise.
- Indica la utilización de/que no utilizar un taladro eléctrico para un paso específico.



- Indicates the number of adults required to perform a specific step, e.g., 2, 3, 4, etc. **You may be able to do certain steps by yourself but, for safety reasons, it's best to have two or more adults. And...it's always easier with one or two helpers.**
- Indique le nombre d'adultes requis pour effectuer une étape spécifique, p. ex., 2, 3, 4, etc. **Il est possible de réaliser certaines étapes seul mais, pour des raisons de sécurité, il est préférable d'être au moins deux adultes. Et... c'est toujours plus facile avec un assistant ou deux.**
- Indica el número de adultos requeridos para realizar un paso específico, p.ej., 2, 3, 4, etc. **Es posible realizar unos pasos solo mas, por razones de seguridad, es mejor tener dos adultos o más. Y... siempre es más fácil con un ayudante o dos.**



- Indicates to repeat a step or an action.
- Indique de répéter une étape ou une action.
- Indica repetir un paso o una acción.

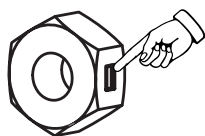

- Indicates the use of a centerlock nut. A nut with this marking will require some effort to tighten. This hardware was designed with this feature in order to prevent loosening later.
- Cette image indique l'usage d'un écrou de blocage central. Un écrou avec ce marquage requerra plus d'effort pour le serrer. Cet écrou a été conçu avec cette fonction afin d'empêcher son desserrage plus tard.
- Indica el uso de una tuerca de bloque central. Una tuerca con esta marca requerirá un poco de esfuerzo para apretarlo. Esta tuerca fue diseñada con esta característica con el fin de evitar su aflojamiento más tarde.

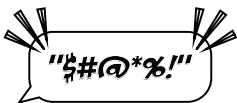

- Indicates a specific step is harder to perform.
- Indique qu'une étape spécifique est plus difficile à exécuter.
- Indica que un paso específico es más difícil de realizar.



- Indicates that one should only hand-tighten the hardware until instructed otherwise.
- Indique qu'il ne faut serrer la quincaillerie qu'à la main jusqu'à ce que l'on reçoive des instructions contraires.
- Indica que sólo se debe apretar a mano el herraje hasta que indique lo contrario.





WARNINGS & NOTICES / AVERTISSEMENTS ET AVIS / ADVERTENCIAS Y AVISOS



English:

- **Failure to follow these warnings may result in serious injury or property damage and will void warranty.**
- To ensure safety, do not attempt to assemble this product without following the instructions carefully.
- Consult all local building codes to verify if the shed requires a building permit.
- Verify the platform foundation is completely level before assembling the shed.
- Be aware that plastic pieces can be damaged by overtightening the screws. To avoid damage, we strongly recommend the use of a drill with a low torque setting. A #2 Phillips screwdriver may also be used.
- Three capable adults are required for assembly.
- All who participate in the assembly process should wear safety glasses throughout the assembly.
- If using a ladder during assembly, use extreme caution.
-  In heavy snowfall areas, we recommend removing snow from the roof. Remove the snow from the roof when the depth of snow equals the length of your hand.
- Do not use or store hot objects near the product.
- Proper and complete assembly are essential to reduce the risk of accident or injury.
- When drilling through metal, beware of burrs, shavings and other sharp edges.
- During and after assembly, do not slide or lift the shed by pushing up on the roof. Move the shed by pushing on the corner panels only.
- Failure to anchor the shed may result in property damage and/or personal injury. The last section, *Shed Anchoring*, in this manual shows the hardware you will need to complete the anchoring. You can find the hardware at your local hardware store.
- **Most injuries are caused by misuse and/or not following instructions. Use caution when using this product.**

Français :

- **Ne pas suivre ces avertissements peut entraîner des blessures graves ou des dommages à la propriété et annulera la garantie.**
- Afin d'assurer la sécurité, ne pas tenter d'assembler ce produit sans suivre attentivement les instructions.
- Consulter tous les codes du bâtiment afin de vérifier si l'abri nécessite un permis de construire.
- Vérifier que la fondation de la plate-forme est complètement à niveau avant l'assemblage de l'abri.
- Ne pas oublier que les pièces de plastique peuvent être endommagées en serrant trop les vis. Afin d'éviter les dommages, nous recommandons fortement l'utilisation d'une perceuse à faible couple. Un tournevis cruciforme n° 2 peut aussi être utilisé.
- Trois adultes en bonne condition physique sont nécessaires pour l'assemblage.
- Tout ceux qui participent au processus de l'assemblage doivent porter des lunettes de sécurité tout au long de l'assemblage.
- Si une échelle est utilisée pour l'assemblage, il faut être extrêmement prudent.
- Dans les zones de fortes tombées de neige, il est recommandé de dégager le toit. Enlever la neige du toit quand la profondeur est égale à la longueur de la main.
- Ne pas utiliser ou entreposer des objets très chauds près de ce produit.
-  Un bon assemblage complet est nécessaire pour réduire le risque d'accident ou de blessure.
-  En perçant le métal, faire attention aux bavures, copeaux et autre bords aiguisés.
- Pendant et après l'assemblage, ne pas faire glisser ou soulever l'abri en poussant le toit vers le haut. Déplacer l'abri en poussant les panneaux muraux angulaires seulement.
- Si vous n'ancrez pas votre abri, des dommages à la propriété et/ou des blessures peuvent en résulter. La dernière section, *Ancrage de l'abri*, de ce manuel indique les matériaux nécessaires pour l'ancrage. Les matériaux se trouvent dans la quincaillerie locale.
- **La majorité des blessures sont causées par une mauvaise utilisation et/ou le non suivi des instructions. Être prudent en utilisant ce produit.**

Español:

- **No seguir estas advertencias puede resultar en lesiones graves o daños a la propiedad y anulará la garantía.**
- A fin de garantizar la seguridad, no intentar ensamblar este producto sin seguir cuidadosamente las instrucciones.
- Consultar todos los códigos de construcción locales para verificar si el cobertizo requiere un permiso de construcción.
- Verificar que el concreto de la plataforma esté nivelado completamente antes de ensamblar el cobertizo.
- Tener en cuenta que las piezas de plástico pueden dañarse si los tornillos se aprietan de más. A fin de evitar daños, lo exhortamos a que use un taladro con función de torque bajo. También puede usarse un desatornillador Phillips no. 2.
- Se necesitan tres adultos para el ensamble.
- Todos los que participen en el proceso de ensamble debe usar anteojos de seguridad durante todo el ensamble.
- Si se usa una escalera durante el ensamblado, es preciso tener cuidado.
- En áreas de nevadas fuertes, recomendamos retirar la nieve del techo. Quitar la nieve del tejado cuando la profundidad de ella es igual a la longitud de la mano.
- No usar ni guardar objetos calientes cerca del producto.
-  El ensamblaje correcto y completo son esenciales para reducir el riesgo de accidente o lesión.
-  Al perforar metal, tenga cuidado las rebabas, virutas y otros bordes afilados.
- Durante y después del ensamblaje, no deslizar ni levantar el cobertizo para empujar en el tejado. Mover el cobertizo para empujar los paneles murales angulares solamente.
- No anclar el cobertizo puede resultar en daños a la propiedad y/o en lesiones personales. La última sección, *Anclaje de el cobertizo*, en este manual muestra el herraje necesaria para terminar el anclaje. Se encuentra el herraje en la ferretería local.
- **La mayoría de las lesiones suceden a causa del mal uso y/o por no seguir las instrucciones. Tener precaución al usar este producto.**



• You must provide a platform on which to assemble your shed. Proper building permit documentation may be required in your neighborhood. Consult all local building codes prior to assembling the shed. Before beginning assembly, you must pour or construct a platform. There are two types:

- Concrete
- Wood Frame

Select the type, but know the surface must be leveled and flat before installation. If the surface is not properly leveled and flat, the shed will not assemble correctly. Proper surface leveling will save you time in the long run, so please do not ignore this step. **We recommend a Concrete platform. It will be the most durable and long-lasting choice. The platform you choose must be built above ground in order to avoid water pooling inside the shed. All lumber must be rated for outdoor use!**



• Il faut construire une plate-forme sur laquelle vous devez assembler votre abri. Il est possible que le quartier exige une documentation visant les permis de construire. Consulter tous les codes du bâtiment locaux, ainsi que les décrets des villes et comtés, pour vérifier que la construction de l'abri extérieur n'exige pas un permis de construire. Avant de commencer l'assemblage, il faut couler ou construire une plate-forme. Il y a deux styles :

- Béton
- Cadre à bois

Sélectionner le style, mais savoir que la surface d'installation doit être de niveau et plate. Si la surface n'est pas correctement de niveau et plate, l'assemblage de l'abri ne se fera pas correctement. On gagnera du temps sur le long terme grâce à une surface bien de niveau, ne négliger donc pas cette étape. **Nous recommandons une plate-forme en béton. Ce choix sera le plus durable. La plate-forme que vous choisissez doit être construite au-dessus du sol afin d'éviter l'accumulation d'eau à l'intérieur de l'abri. Tous le bois d'oeuvre doit être approuvé pour l'usage à l'extérieur !**



• Es preciso construir una plataforma sobre la cual usted debe ensamblar su caseta. Puede suceder que en el vecindario se requiera la documentación apropiada de un permiso de construcción. Consultar todos los códigos locales de construcción y los reglamentos de la ciudad y el municipio para asegurarse de que la construcción de la caseta no requiere un permiso de construcción. Antes de comenzar el ensamble, es necesario verter o construir una plataforma. Hay dos clases:

- Concreto
- Armazón de madera

Seleccionar la clase, mas saber que la superficie debe estar nivelada y plana antes de comenzar el ensamble. Si la superficie no está nivelada y plana de manera adecuada, la caseta no podrá ensamblarse correctamente. La nivelación de la superficie le ahorrará tiempo de trabajo, por lo tanto, le pedimos que no ignore este paso. **Recomendamos una plataforma hecho de concreto. Será la elección más perdurable. La plataforma debe ser construida arriba del suelo para evitar el flujo de agua dentro de la caseta. ¡Toda la madera debe estar clasificada para el uso externo!**

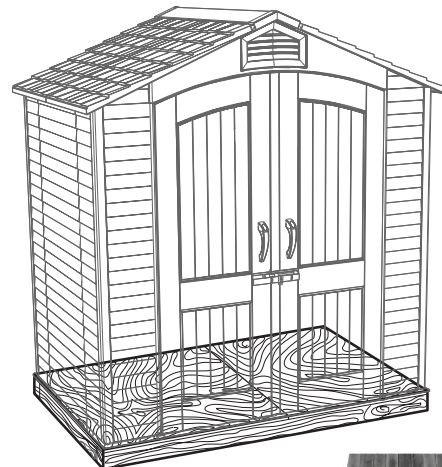
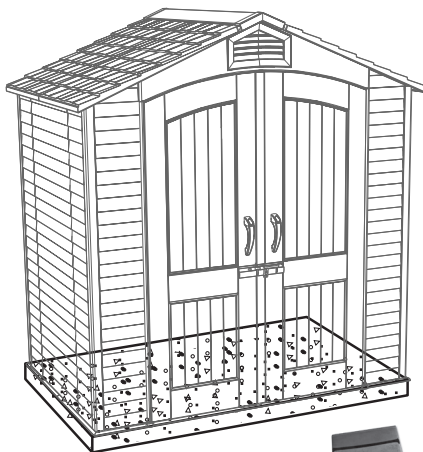

SECTION 1 (CONTINUED) / SECTION 1 (SUITE) / SECCIÓN 1 (CONTINUACIÓN)

CONCRETE REQUIRED / BÉTON REQUIS / CONCRETO REQUERIDO



1 yd³ (≈0,77 m³)

1.1

CONCRETE PLATFORM / PLATE-FORME EN BÉTON / PLATAFORMA DE CONCRETO

- The concrete should be approximately 4" (≈10,2 cm) thick. The actual dimensions of the shed, at its widest and longest points, are 84" x 56" (≈2,13 m x ≈1,42 m). Ensure you select a site that will accommodate these measurements. **The floor dimensions are a bit smaller than those of the roof; therefore, you will need to build a level surface of 81 1/2" x 54" (≈2,07 m x ≈1,37 m).**
- Le béton doit être une épaisseur de ≈10,2 cm (4 po). Les dimensions réelles de votre abri, aux points les plus large et long, sont ≈2,13 m x ≈1,42 m (84 po x 56 po). Veiller à sélectionner un site qui accommodera ces dimensions. **Les dimensions du plancher de l'abri sont plus petites que le toit; ensuite, il faut créer une surface nivelée de ≈2,07 m x ≈1,37 m (81 1/2 po x 54 po).**
- El concreto debe tener, por lo menos, ≈10,2 cm (4 in) de espesor. Las dimensiones reales de la caseta, a sus puntos más anchos y largos, son ≈2,13 m x ≈1,42 m (84 in x 56 in). Asegurarse de seleccionar un sitio que acomodará estas medidas. **Las dimensiones del piso de la caseta son más pequeñas que el tejado; entonces, es necesario crear una superficie nivelada de ≈2,07 m x ≈1,37 m (81 1/2 in x 54 in).**

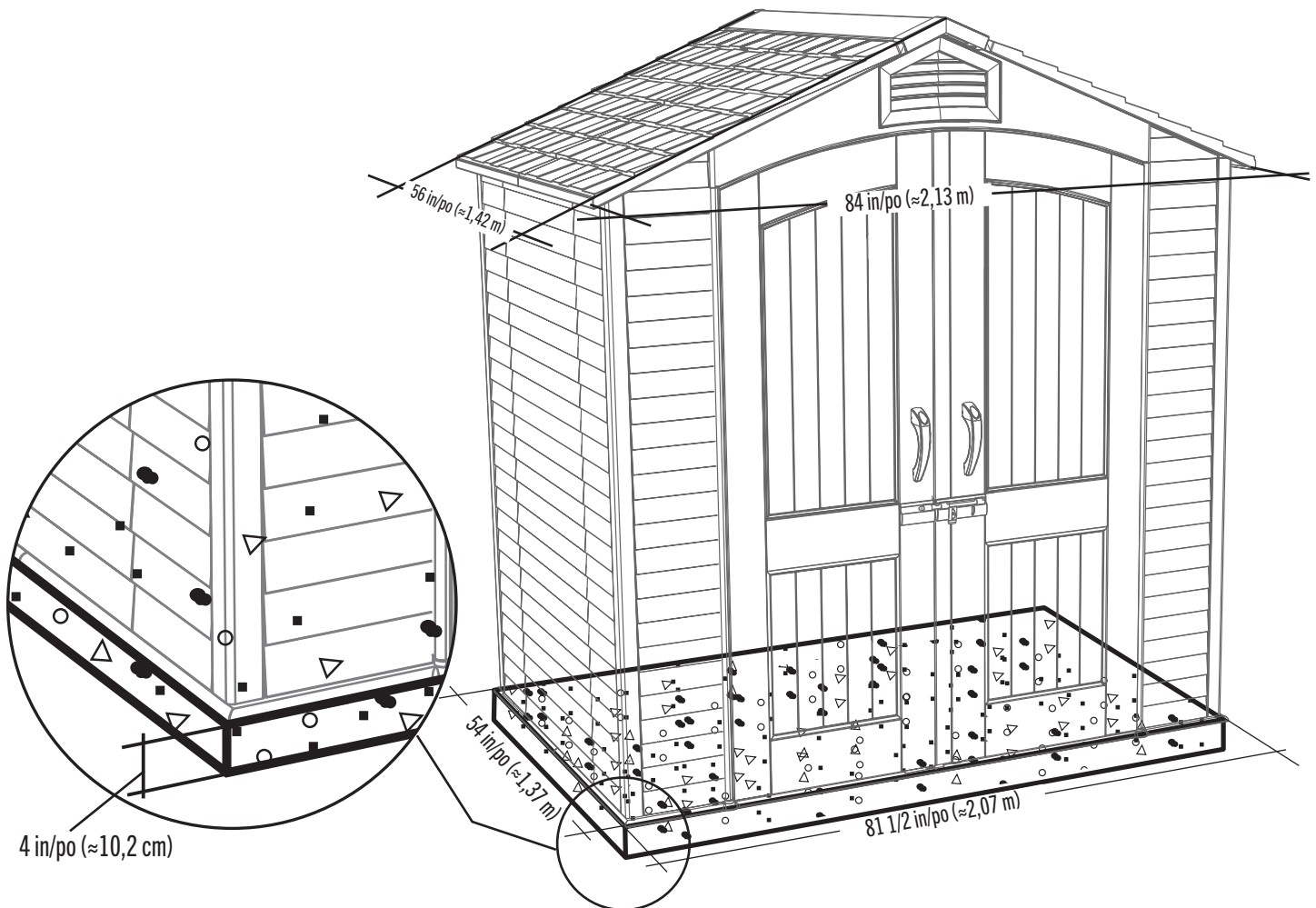

► SECTION 1 (CONTINUED) / SECTION 1 (SUITE) / SECCIÓN 1 (CONTINUACIÓN)

WOOD REQUIRED / BOIS REQUIS / MADERA REQUERIDA



1.2

WOOD PLATFORM / PLATE-FORME EN BOIS / PLATAFORMA DE MADERA

- The actual dimensions of the shed, at its widest and longest points, are 84" x 56" ($\approx 2,13$ m x $\approx 1,42$ m). Ensure you select a site that will accommodate these measurements. **The floor dimensions are a bit smaller than those of the roof; therefore, you will need to build a level surface of 81 1/2" x 54" ($\approx 2,07$ m x $\approx 1,37$ m).**
- Les dimensions réelles de l'abri, aux points les plus larges et longs, sont $\approx 2,13$ m x $\approx 1,42$ m (84 po x 56 po). Veiller à sélectionner un site qui accommodera ces dimensions. **Les dimensions du plancher de votre abri sont plus petites que le toit; ensuite, il faut créer une surface nivelée de $\approx 2,07$ m x $\approx 1,37$ m (81 1/2 po x 54 po).**
- Las dimensiones reales de la caseta, a sus puntos más anchos y más largos, son $\approx 2,13$ m x $\approx 1,42$ m (84 in x 56 in). Asegurarse de seleccionar un sitio que acomodará estas medidas. **Las dimensiones del piso de la caseta son más pequeñas que el tejado; entonces, es necesario crear una superficie nivelada de $\approx 2,07$ m x $\approx 1,37$ m (81 1/2 in x 54 in).**

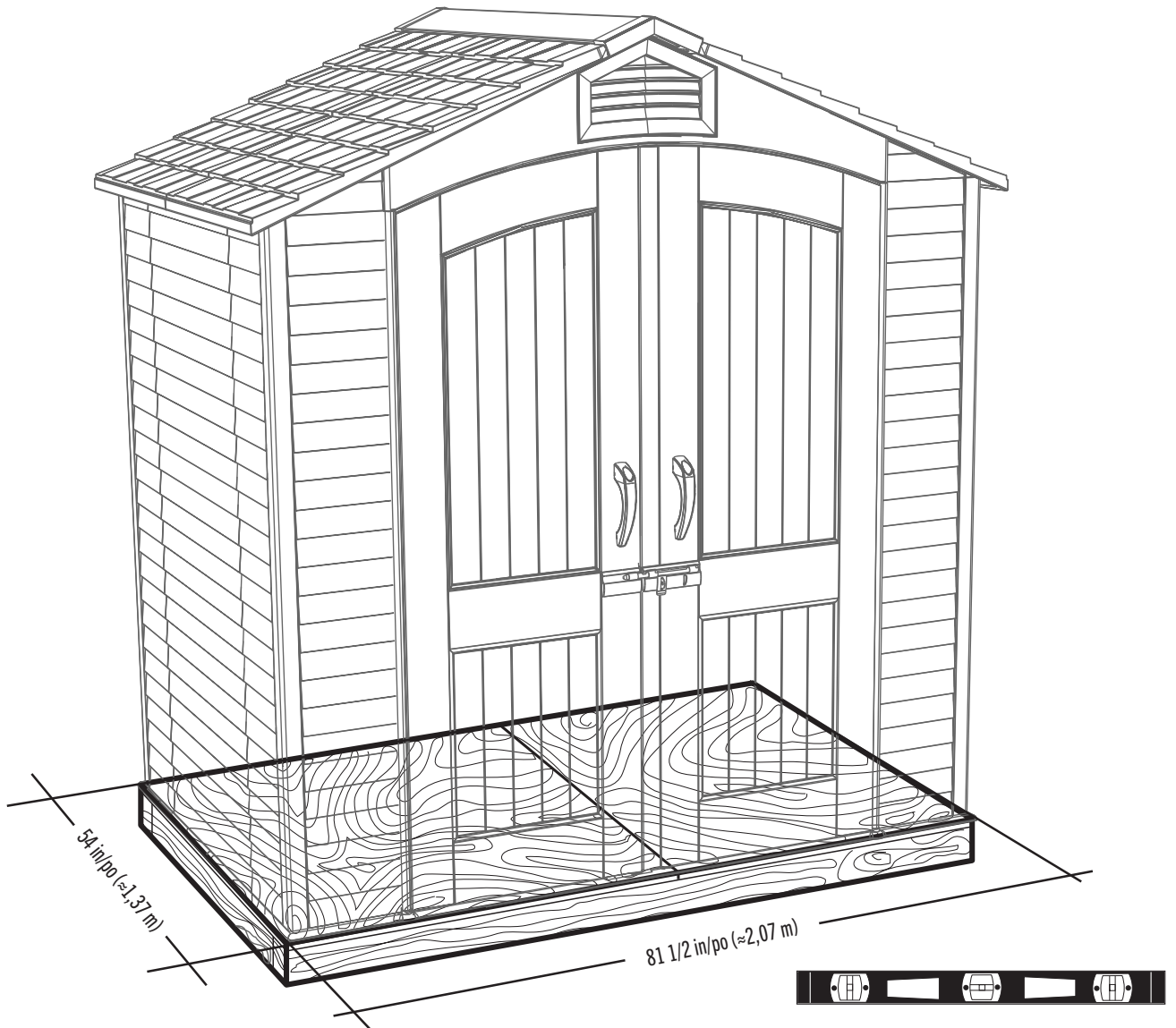

SECTION 1 (CONTINUED) / SECTION 1 (SUITE) / SECCIÓN 1 (CONTINUACIÓN)

TOOLS, PARTS, AND HARDWARE REQUIRED / OUTILS, PIÈCES, ET ACCESSOIRES REQUIS / INSTRUMENTAL, PIEZAS, Y HERRAJE REQUERIDOS

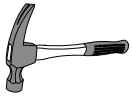

2 in/po x 4 in/po x 81 1/2 in/po (≈5,1 cm x ≈10,2 cm x ≈2,07 m) (x2)



2 in/po x 4 in/po x 51 in/po (≈5,1 cm x ≈10,2 cm x ≈1,3 m) (x7)

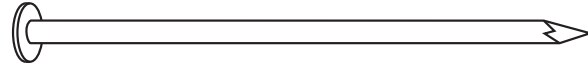

16d 3 1/2 in/po (16d x ≈8,89 cm) (x28)

1.2.1

WOOD PLATFORM / PLATE-FORME EN BOIS / PLATAFORMA DE MADERA

- Ensure all lumber is treated and approved for outdoor use. Build frame to 81 1/2" x 54" (≈2,07 m x ≈1,37 m) (outside dimensions). You can also use the plywood as a flat surface when building this frame.
- Vérifier que votre bois d'œuvre a été traité et approuvé pour l'utilisation à l'extérieur. Contruiser un cadre de ≈2,07 m x ≈1,37 m (81 1/2 po x 54 po) (dimensions extérieures). On peut aussi utiliser le contreplaqué comme une surface plate pendant l'assemblage de ce cadre.
- Asegúrese que use madera tratada y aprobada para el uso externo. Construya el armazón a ≈2,07 m x ≈1,37 m (81 1/2 in x 54 in) (dimensiones exteriores). Se puede también usar el contrachapado como una superficie plana al ensamblar este armazón.

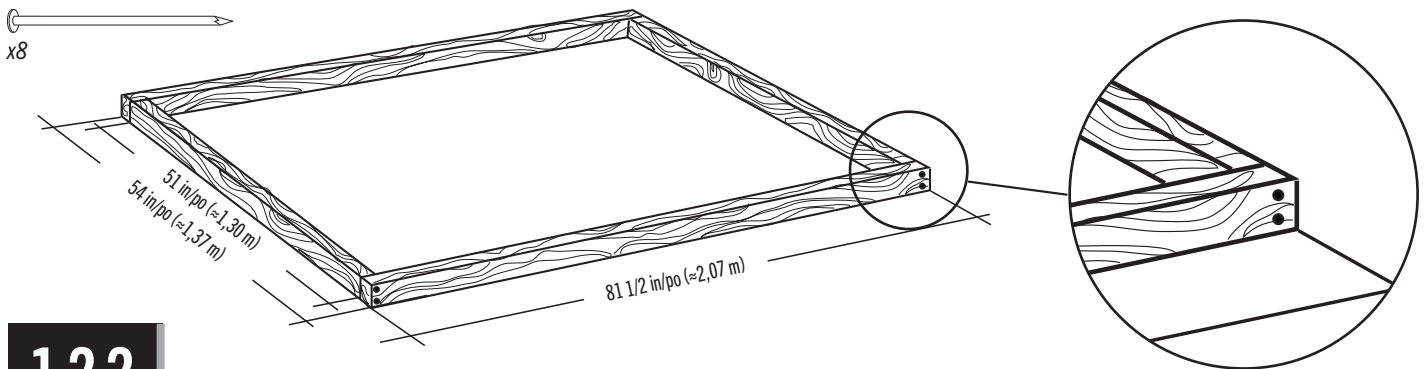

1.2.2

- To ensure studs are in the correct location for nailing plywood in the next step, start measuring from the corner 16" (≈40,1 cm), and then measure from center to center.
- Pour être sûr d'avoir assez de montant pour clouer le contreplaqué dans la prochaine étape, commencer à mesurer à partir de cette montant ≈40,1 cm (16 po) vers le centre du deuxième montant. Ensuite, mesurer de centre à centre pour les montants restants.
- Para asegurarse que los montantes están en las ubicaciones correctas para el contrachapado en el paso siguiente, comenzar a medir desde el borde del montante hasta el centro del próximo montante ≈40,1 cm (16 in). Luego, tomar la medida de centro a centro en los montantes restantes.

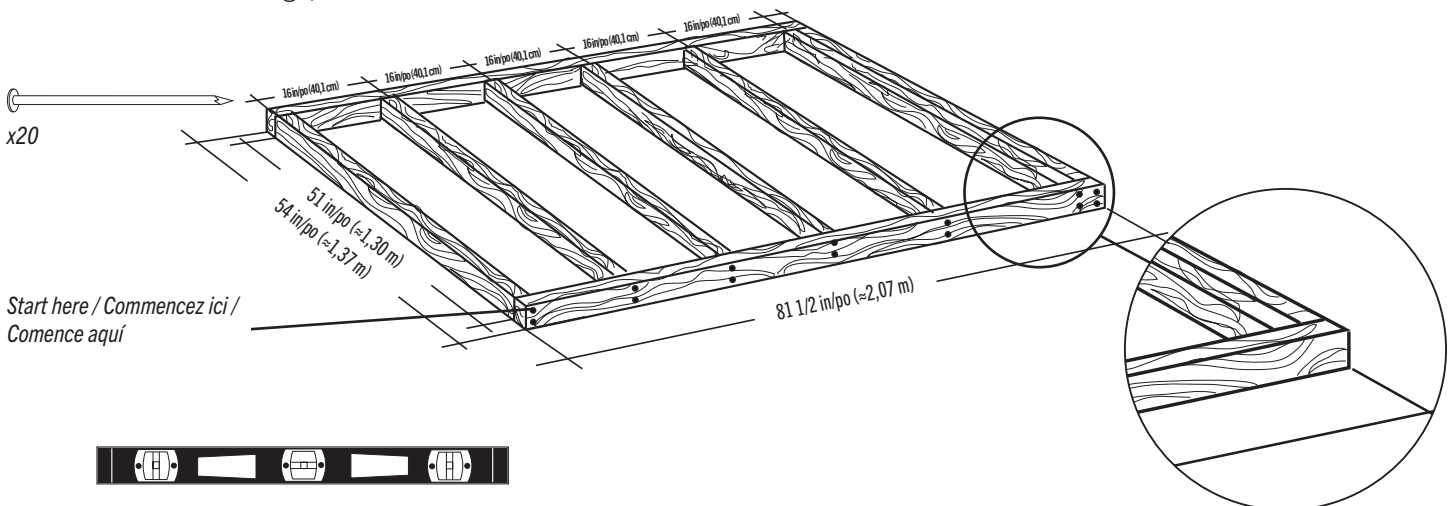

SECTION 1 (CONTINUED) / SECTION 1 (SUITE) / SECCIÓN 1 (CONTINUACIÓN)

TOOLS, PARTS, AND HARDWARE REQUIRED / OUTILS, PIÈCES, ET QUINCAILLERIE REQUIS / INSTRUMENTAL, PIEZAS, Y HERRAJE REQUERIDOS

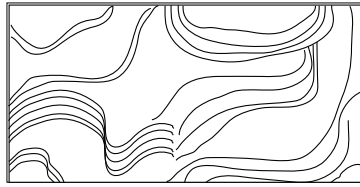
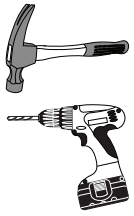

48 in/po x 54 in/po x 3/4 in/po
(≈1,22 m x ≈1,37 m x ≈19,1 mm) (x1)

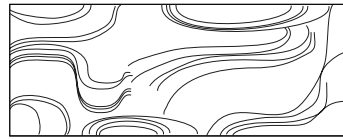

33 1/2 in/po x 54 in/po x 3/4 in/po
(≈85,1 cm x ≈1,37 m x ≈19,1 mm) (x1)



8d 2 1/2 in/po (8d, ≈6,35 cm) (x32)

1.2.3

- Square the frame, measuring from corner to corner. **Measurement A and B should be about the same length.**
- Carrer le cadre en mesurant d'angle à angle. **La mesure « A » et « B » doivent être à peu près la même longueur.**
- Cuadrar el armazón midiendo de esquina a esquina. **La medida «A» y «B» deben ser aproximadamente el mismo largo.**

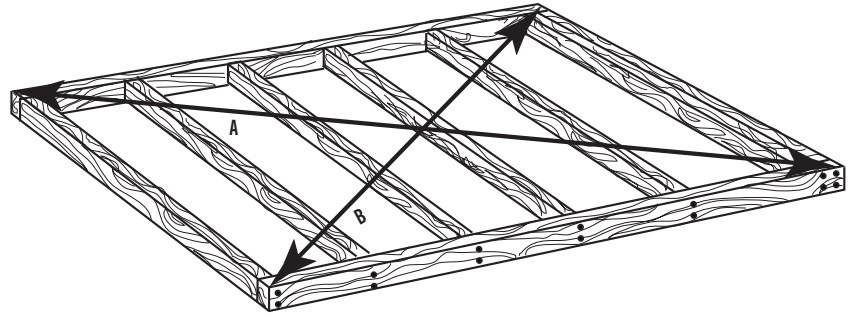

1.2.4

- Using nails, fasten the plywood to the frame. Then, drill 5/16" (≈8 mm) holes for drainage.
- En utilisant des clous, attacher bien le contreplaqué au cadre. Ensuite, percer des trous de ≈8 mm pour le drainage.
- Usando unos clavos, sujetar el contrachapado al armazón. Entonces, taladrar agujeros de ≈8 mm para el drenaje.

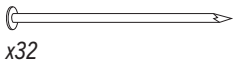

x32

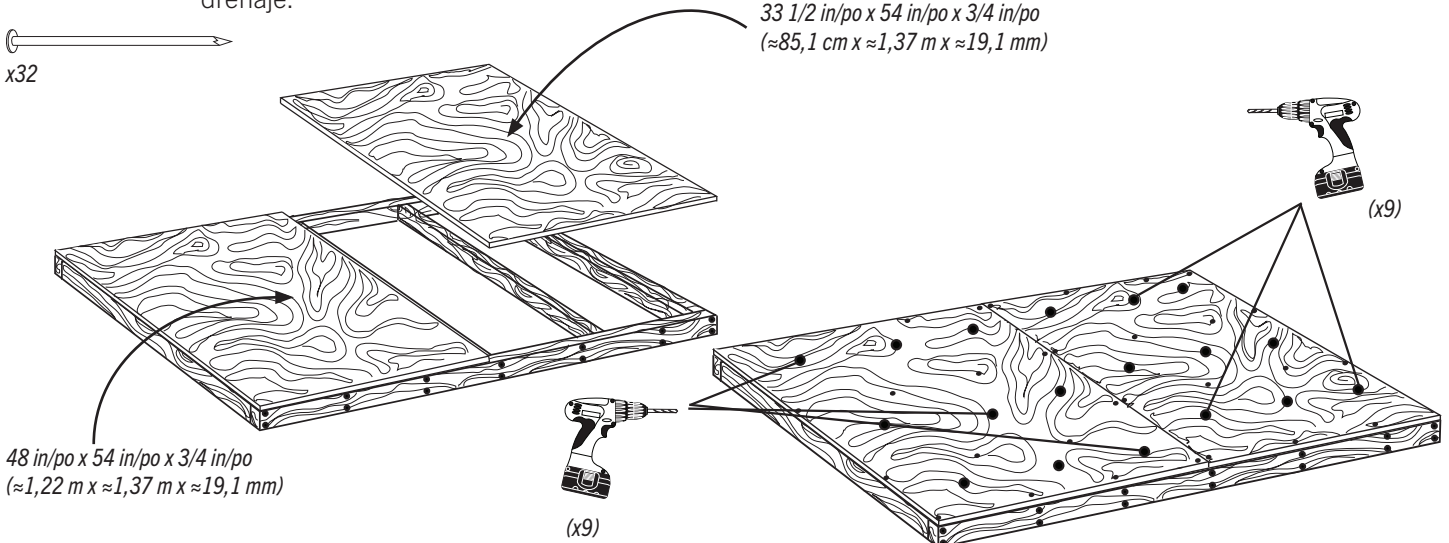

48 in/po x 54 in/po x 3/4 in/po
(≈1,22 m x ≈1,37 m x ≈19,1 mm)

33 1/2 in/po x 54 in/po x 3/4 in/po
(≈85,1 cm x ≈1,37 m x ≈19,1 mm)

(x9)

(x9)



- 5/16" (≈8 mm) drainage holes
- Trous de drainage de ≈8 mm
- Agujeros para canalización de ≈8 mm

x18!

2

TRUSS ASSEMBLY / ASSEMBLAGE DES FERMES / ENSAMBLAJE DE LAS CERCHAS



HARDWARE REQUIRED / QUINCAILLERIE REQUISE / HERRAJE REQUERIDO

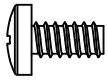

ADY (x4)



ADJ (x2)



CXK (x8)

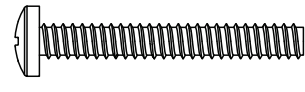

ETC (x4)

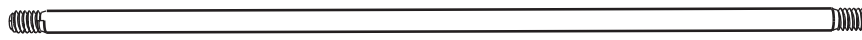

ADH (x1)

8 1/4 in/po (20,96 cm)



PARTS REQUIRED / PIÈCES REQUISES / PIEZAS REQUERIDAS

Metal parts / Pièces en métal / Piezas de metal

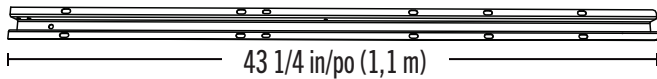

AFH (x2)

43 1/4 in/po (1,1 m)

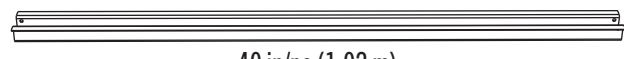

AFG (x1)

40 in/po (1,02 m)

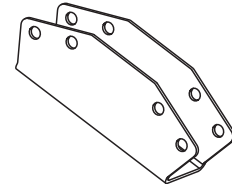

ETD (x1)



TOOLS REQUIRED / OUTILS REQUIS / INSTRUMENTAL REQUERIDO

(Not included—unless otherwise indicated*) / (Non inclus — sauf indication contraire*) / (No incluido, salvo indicación contraria*)



7/16 in/po (≈11 mm) (x2)



3/8 in/po (≈10 mm)

► SECTION 2 (CONTINUED) / SECTION 2 (SUITE) / SECCIÓN 2 (CONTINUACIÓN)

TOOLS AND HARDWARE REQUIRED / OUTILS ET QUINCAILLERIE REQUIS / INSTRUMENTAL Y HERRAJE REQUERIDOS



- If you have trouble with this section, follow the code below to view a video on the assembly in this section.
- En cas de problèmes avec cette section, suivre le code en bas pour voir un vidéo sur l'assemblage à cette section.
- En caso de problemas con esta sección, seguir el código debajo para ver un video sobre el ensamble en esta sección.



<http://go.lifetime.com/7truss>

2.1

- Align the holes in a **connector (ETD)** with those in the ends of the **truss channels (AFH)**.
- Aligner les trous dans le **connecteur (ETD)** avec ceux aux extrémités des **canaux (AFH)**.
- Alinear los agujeros en el **conector (ETD)** con ellos a los extremos de los **canalones (AFH)**.

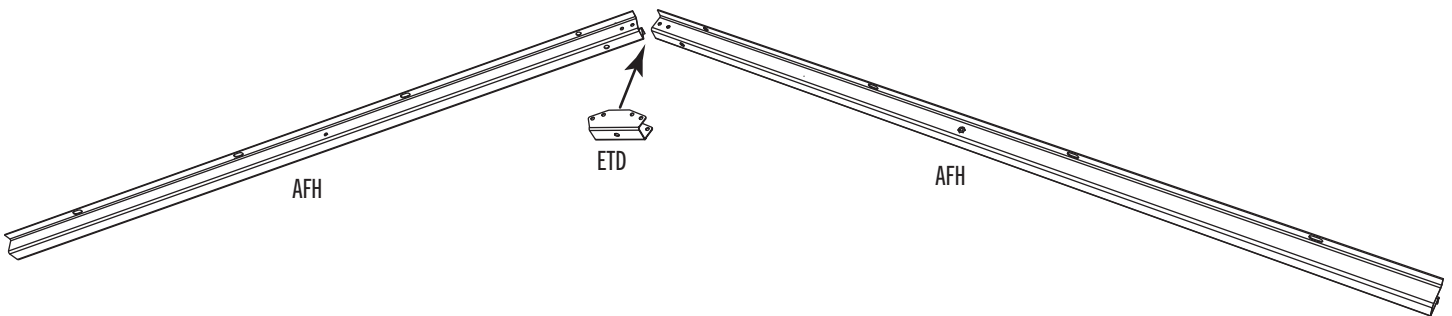

► SECTION 2 (CONTINUED) / SECTION 2 (SUITE) / SECCIÓN 2 (CONTINUACIÓN)

TOOLS AND HARDWARE REQUIRED / OUTILS ET QUINCAILLERIE REQUIS / INSTRUMENTAL Y HERRAJE REQUERIDOS

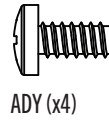
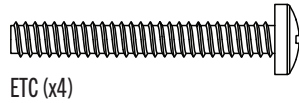
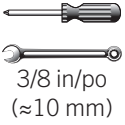

2.2

- Secure the connector to the truss gutter channels using the hardware included.
- Attacher le connecteur aux canaux à l'aide de la quincaillerie incluse.
- Sujetar el conector a los canales usando el herraje incluido.

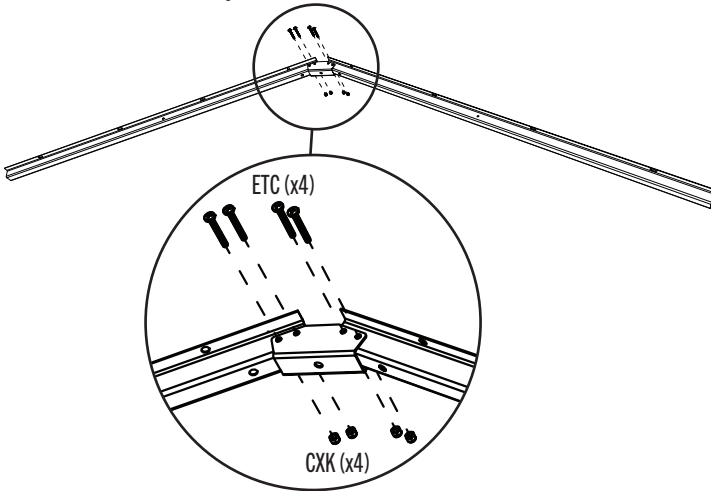

2.3

- Align the holes in a **truss brace (AFG)** with those in the truss gutter channels.
- Aligner les trous dans le **support de la ferme (AFG)** avec ceux des canaux de gouttière.
- Alinear los agujeros en el **soporte de la cercha (AFG)** con ellos en los canalones de la cercha.

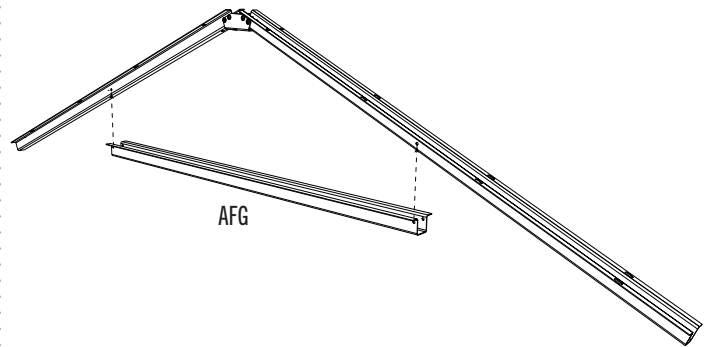

2.4

- Attach the truss brace to the truss gutter channels using the hardware included.
- Attacher le support de ferme aux canaux à l'aide de la quincaillerie incluse.
- Sujetar el soporte de cercha a los canalones usando el herraje incluido.

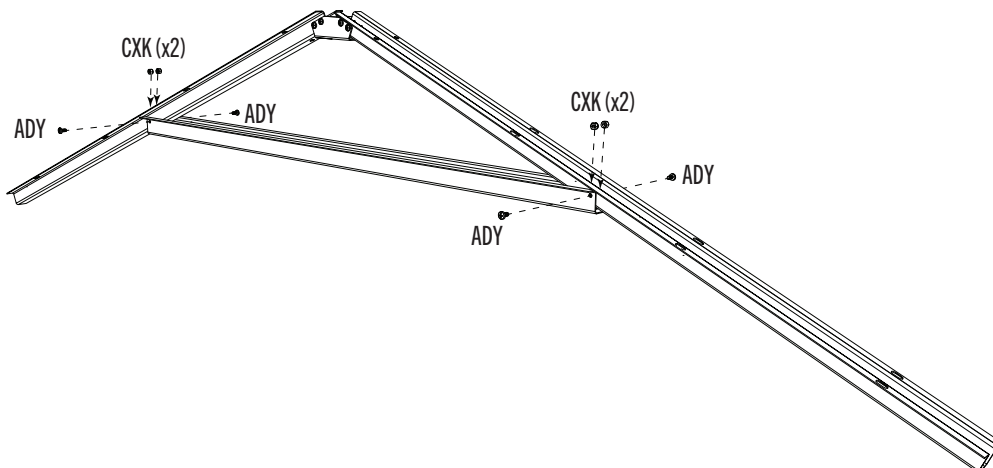

SECTION 2 (CONTINUED) / SECTION 2 (SUITE) / SECCIÓN 2 (CONTINUACIÓN)

TOOLS AND HARDWARE REQUIRED / OUTILS ET QUINCAILLERIE REQUIS / INSTRUMENTAL Y HERRAJE REQUERIDOS



7/16 in/po
(≈11 mm)
(x2)

8 1/4 in/po (20,96 cm)
ADH (x1)

ADJ (x2)

2.5

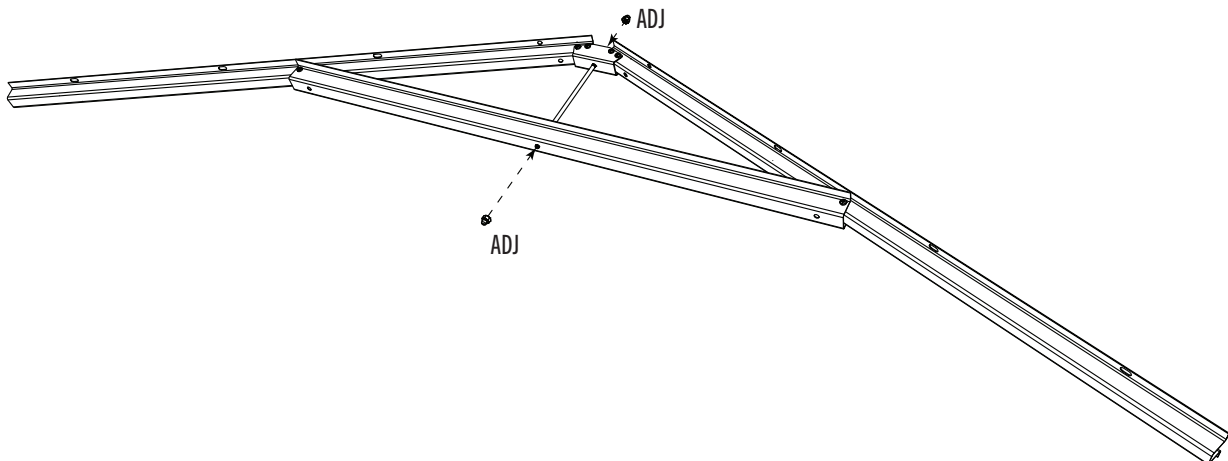
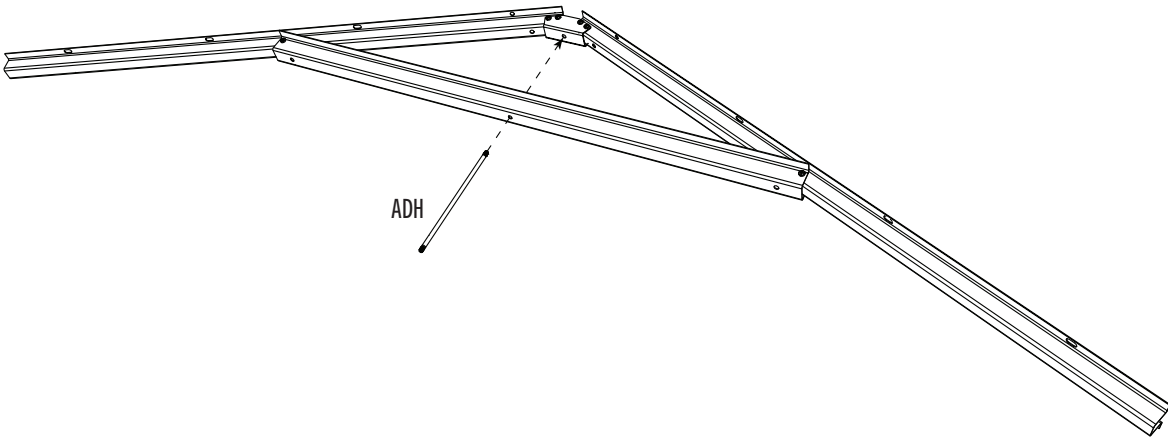
- Slide a **truss rod (ADH)** through the holes in the truss brace and connector. Secure with two **cap nuts (ADJ)**. Lay truss flat and tighten all hardware securely.
- Faire glisser un **support de la ferme (ADH)** à travers les trous dans le support et le connecteur. Attacher-le bien à l'aide des **écrous borgnes (ADJ)**. Serrer bien toute la quincaillerie.
- Deslizar un **varilla del soporte (ADH)** por los agujeros en el soporte y el conector. Sujetarlo bien usando las **tuercas ciegas (ADJ)**. Apretar bien todo el herraje.



3

GABLE ASSEMBLY / ASSEMBLAGE DES PIGNONS / ENSAMBLAJE DE LAS FACHADAS



HARDWARE REQUIRED / QUINCAILLERIE REQUISE / HERRAJE REQUERIDO

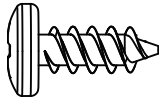

ADZ (x3)

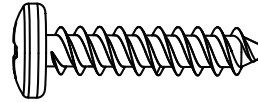

ADV (x6)



PARTS REQUIRED / PIÈCES REQUISES / PIEZAS REQUERIDAS

Metal parts / Pièces en métal / Piezas de metal

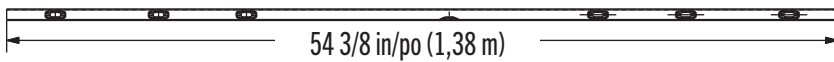

AFE (x1)

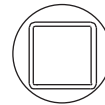

Plastic parts / Pièces en plastique / Piezas de plástico



AGF (x1)

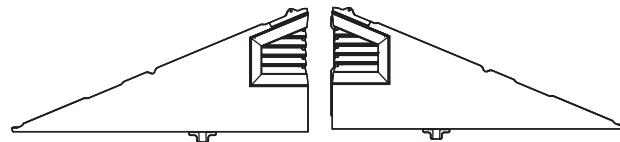

AGI (x1)

AGH (x1)



TOOLS REQUIRED / OUTILS REQUIS / INSTRUMENTAL REQUERIDO

(Not included—unless otherwise indicated) / (Non inclus — sauf indication contraire*) / (No incluido, salvo indicación contraria*)*



► SECTION 3 (CONTINUED) / SECTION 3 (SUITE) / SECCIÓN 3 (CONTINUACIÓN)

TOOLS AND HARDWARE REQUIRED/ OUTILS ET QUINCAILLERIE REQUIS / INSTRUMENTAL Y HERRAJE REQUERIDOS

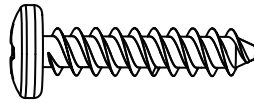

ADV (x6)



- In case of any trouble with this section, scan the QR code below to view a video on its assembly.
- En cas de problème avec cette section, scanner le QR code en dessous pour voir une vidéo de l'assemblage.
- En caso de problemas con esta sección, escanear el código QR debajo para ver un video del ensamblaje.

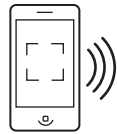

<http://go.Lifetime.com/7x7shed-section3>

3.1

- Align the holes in the **lintel (AFE)** with those in the **entry gable (AGF)**.
- Aligner les trous dans le **linteau (AFE)** avec ceux du **pignon d'entrée (AGF)**.
- Alinear los agujeros en el **dintel (AFE)** con ellos en la **fachada de entrada (AGF)**.

- The flat holes face away from the gable.
- Les trous plats doivent être face à l'écart du pignon.
- Los agujeros planos dan hacia afuera.

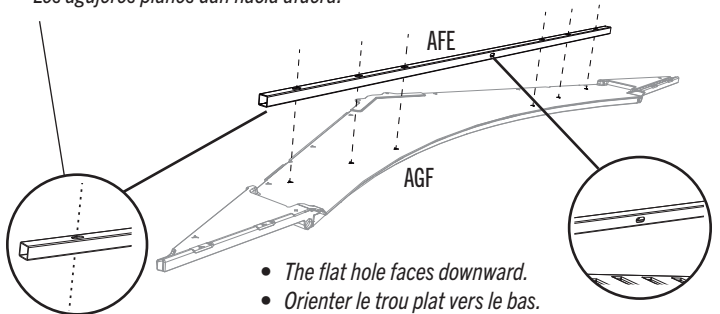

- The flat hole faces downward.
- Orienter le trou plat vers le bas.
- Orientar el agujero plano hacia abajo.

3.2



- Secure with the hardware included.
- Fixer les uns aux autres en utilisant la quincaillerie incluse.
- Fijar los unos a los otros usando el herraje incluido.

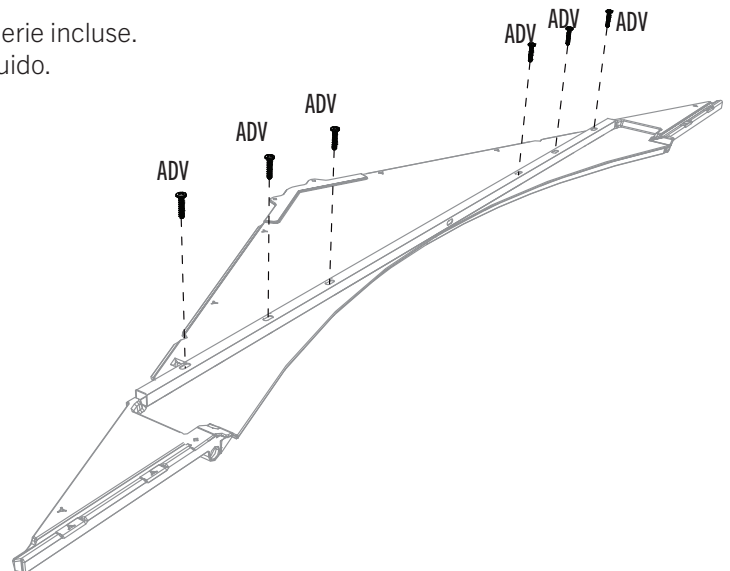

SECTION 3 (CONTINUED) / SECTION 3 (SUITE) / SECCIÓN 3 (CONTINUACIÓN)

TOOLS AND HARDWARE REQUIRED/ OUTILS ET QUINCAILLERIE REQUIS / INSTRUMENTAL Y HERRAJE REQUERIDOS

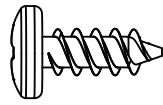

ADZ (x3)

3.3

- Align the holes in the **left (AGH)** and **right (AGI)** rear gable halves.
- Aligner les trous dans les **toits à pignons gauche (AGH)** et **droite (AGI)**.
- Alinear los agujeros en las **fachadas traseras izquierda (AGH)** y **derecha (AGI)**.

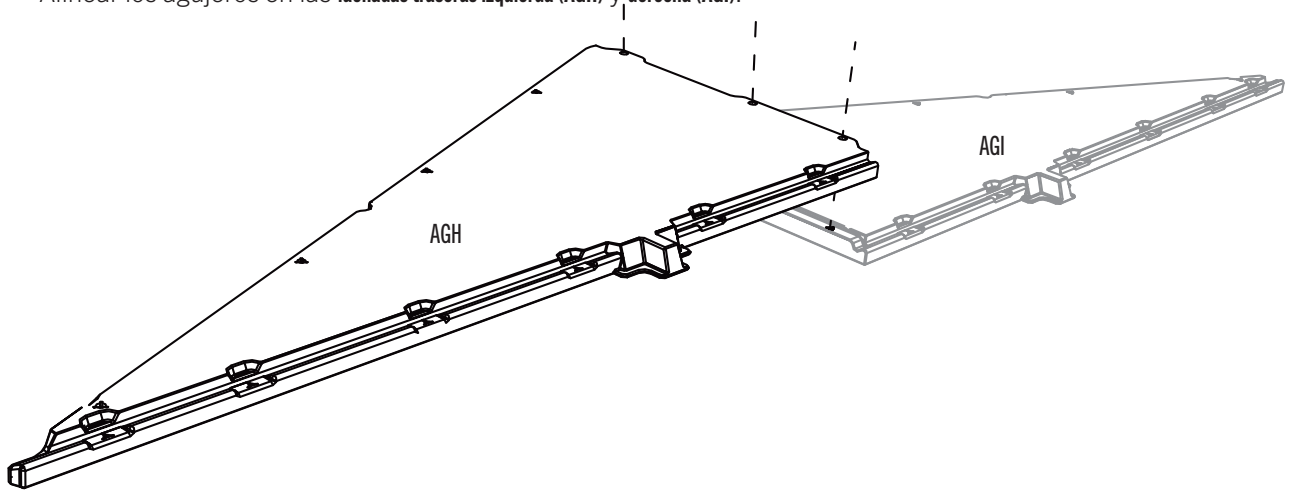

3.4

- Secure the two together with three (3) **screws (ADZ)**.
- Fixer l'un à l'autre à l'aide de trois (3) **vis (ADZ)**.
- Fijar el uno al otro usando tres (3) **tornillos (ADZ)**.

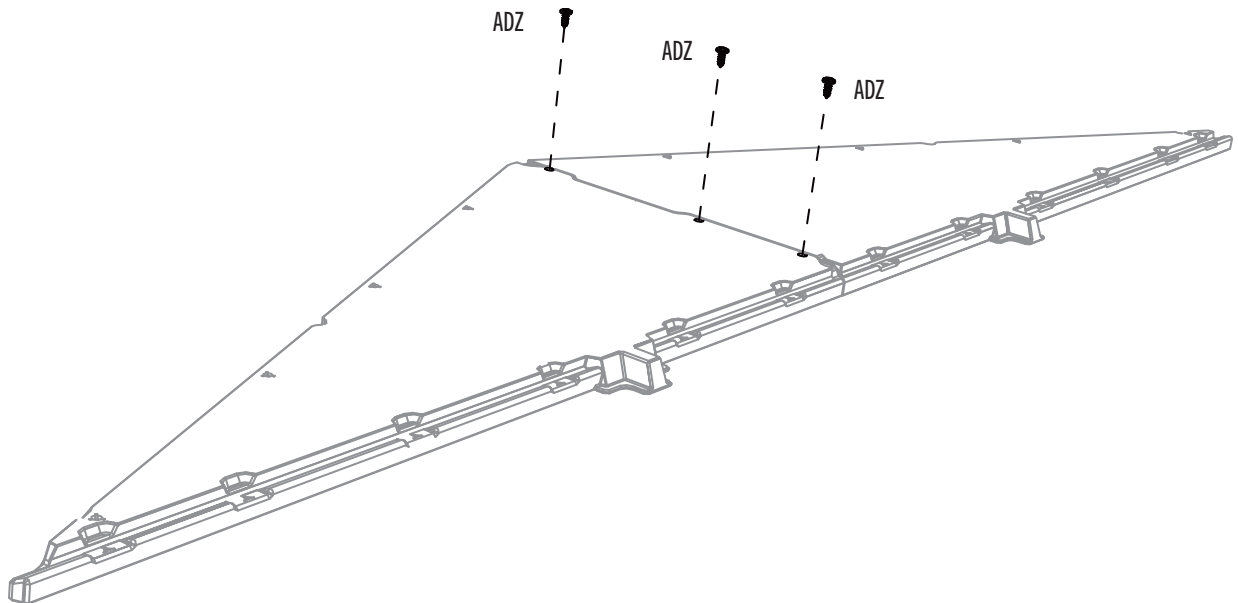

4

LEFT DOOR ASSEMBLY / ASSEMBLAGE DE LA PORTE GAUCHE / ENSAMBLAJE DE LA PUERTA IZQUIERDA



HARDWARE REQUIRED / QUINCAILLERIE REQUISE / HERRAJE REQUERIDO

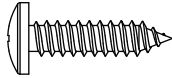

ADW (x1)

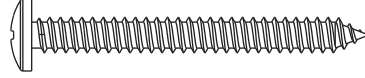

BYZ (x2)

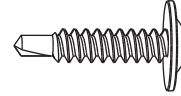

CHK (x5)

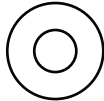

AEE (x3)

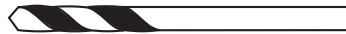

ARA (x1)

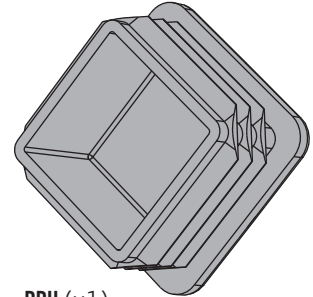

BBH (x1)

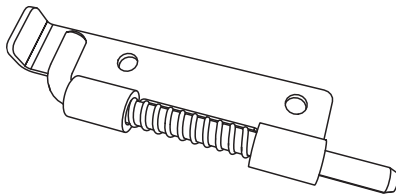

DGR (x1) (*Bottom / Inférieur / Inferior*)

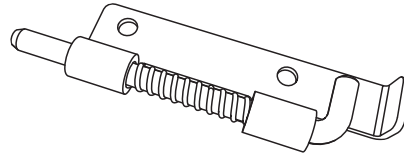

DGS (x1) (*Top / Supérieur / Superior*)



PARTS REQUIRED / PIEZAS REQUERIDAS / PIÈCES REQUISES

Metal parts / Pièces en métal / Piezas de metal

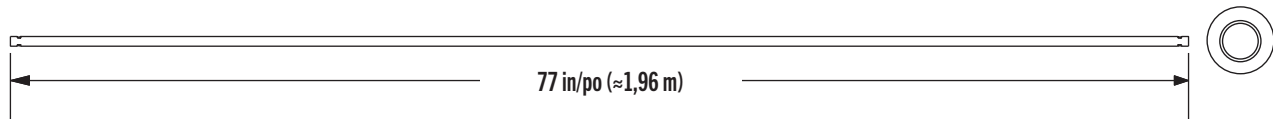

CHH (x1)

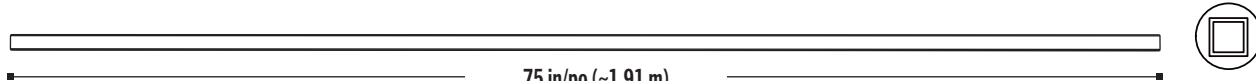

CHI (x1)

4

LEFT DOOR ASSEMBLY / ASSEMBLAGE DE LA PORTE GAUCHE / ENSAMBLAJE DE LA PUERTA IZQUIERDA



PARTS REQUIRED / PIEZAS REQUERIDAS / PIÈCES REQUISES

Plastic parts / Pièces en plastique / Piezas de plástico

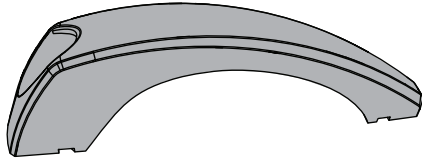

BYR (x1)



BYR (x1)

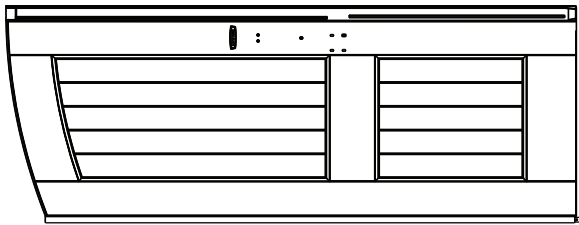

AGO (x1)



TOOLS REQUIRED / OUTILS REQUIS / INSTRUMENTAL REQUERIDO

(Not included—unless otherwise indicated*) / (Non inclus — sauf indication contraire*) / (No incluido, salvo indicación contraria*)



ARA (x1)*

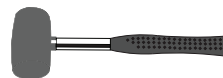

► SECTION 4 (CONTINUED) / SECTION 4 (SUITE) / SECCIÓN 4 (CONTINUACIÓN)

TOOLS AND HARDWARE REQUIRED / OUTILS ET QUINCAILLERIE REQUIS / INSTRUMENTAL Y HERRAJE REQUERIDOS



- In case of any trouble with this section, scan the QR code below to view a video on its assembly.
- En cas de problème avec cette section, scanner le QR code en dessous pour voir une vidéo de l'assemblage.
- En caso de problemas con esta sección, escanear el código QR debajo para ver un video del ensamblaje.

 YouTube

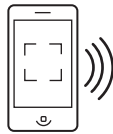

<http://go.lifetime.com/7x7shed-section4>

4.1

- Slide a **hinge tube (CHH)** down into the hole in the **left door (AGO)**.
- Faire glisser le **tube d'articulation (CHH)** dans le trou dans la **porte gauche (AGO)**.
- Deslizar el **tubo de articulación (CHH)** en el agujero en la **puerta izquierda (AGO)**.

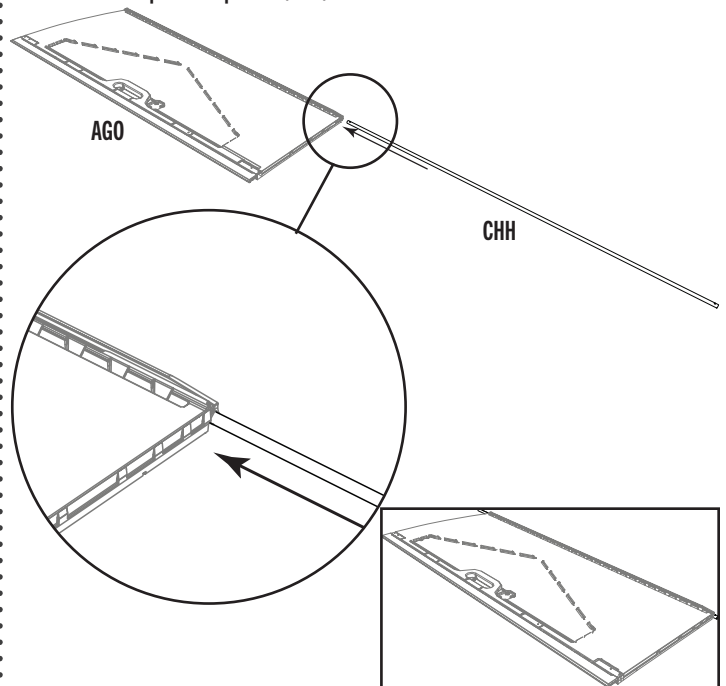

4.2

- Insert a **square tube (CHI)** into the square hole in the bottom of the door until the end hangs out about 1/2" (≈ 12 mm).
- Insérer un **tube carré (CHI)** dans le trou carré au fond de la port jusqu'à ce que l'extrémité dépasse à peu près 1/2 po (≈ 12 mm).
- Insertar un **tubo cuadrado (CHI)** en el agujero cuadrado al fondo de la puerta hasta que el extremo extienda unos 1/2" (≈ 12 mm).

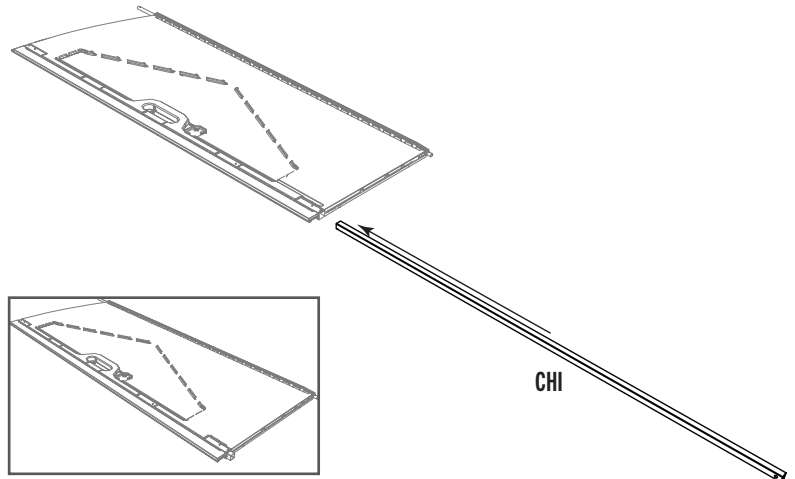

► SECTION 4 (CONTINUED) / SECTION 4 (SUITE) / SECCIÓN 4 (CONTINUACIÓN)

TOOLS AND HARDWARE REQUIRED / OUTILS ET QUINCAILLERIE REQUIS / INSTRUMENTAL Y HERRAJE REQUERIDOS

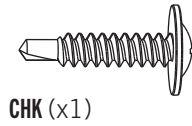

CHK (x1)

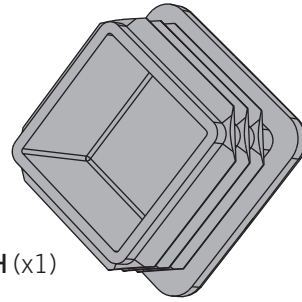

BBH (x1)

4.3

- Insert an **end cap (BBH)** into the end of the **square tube (CHI)**. Gently, finish inserting the tube until it's flush with the bottom of the door.
- Insérer un **capuchon (BBH)** dans l'extrémité du **tube carré (CHI)**. Insérer gentiment le tube jusqu'à ce qu'il soit aligné avec le fond de la porte.
- Insertar un **tapón (BBH)** en el extremo del **tubo cuadrado (CHI)**. Insertar ligeramente el tubo hasta que esté alineado con el fondo de la puerta.

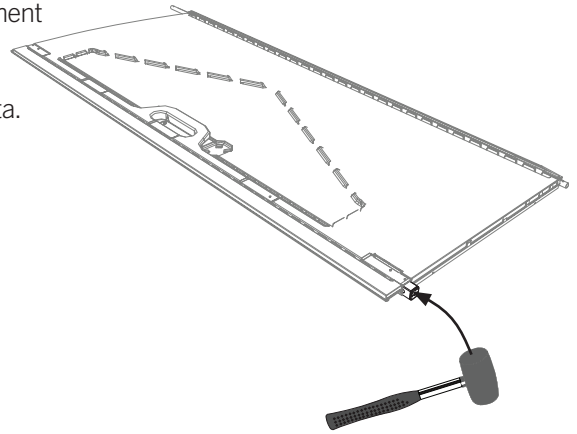
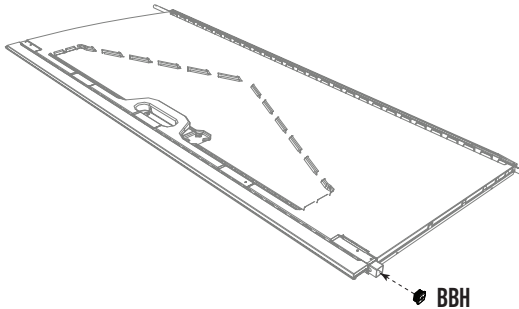

4.4

- Once the end cap is flush with the bottom of the door, insert **self-drilling/self-tapping screw (CHK)** into the door panel at the location shown to hold the square tube in place.
- Une fois que le capuchon soit a ras du bord inférieur de la porte, insérer une **vis autoperceuse/autotaraudeuse (CHK)** dans la porte à l'emplacement indiqué afin de maintenir le tube carré en place.
- Una vez que el tapón esté a ras del borde inferior de la puerta, insertar un **tornillo auto-perforante/auto-roscante (CHK)** en la puerta a la ubicación ilustrada para mantener el tubo cuadrado en su lugar.

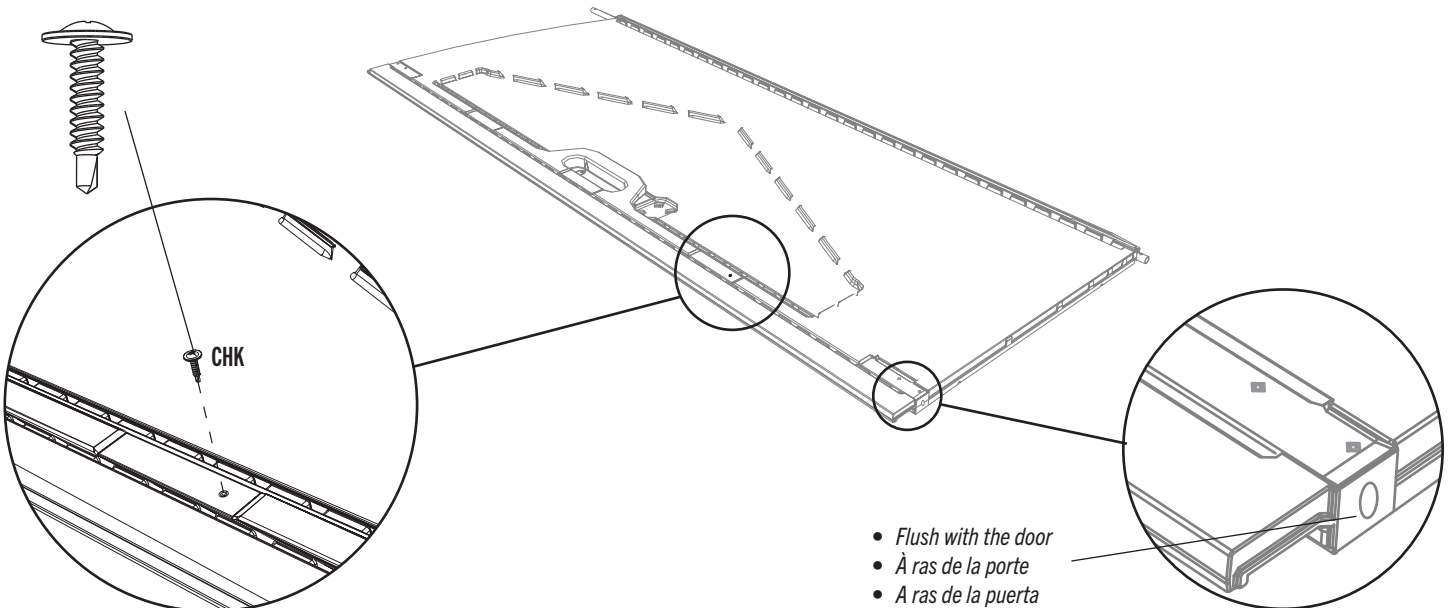

- *Flush with the door*
- *À ras de la porte*
- *A ras de la puerta*

► SECTION 4 (CONTINUED) / SECTION 4 (SUITE) / SECCIÓN 4 (CONTINUACIÓN)

TOOLS AND HARDWARE REQUIRED / OUTILS ET QUINCAILLERIE REQUIS / INSTRUMENTAL Y HERRAJE REQUERIDOS



ARA (x1)



4.5

- Drill two holes at the top and bottom of the door at the locations indicated.
- Percer deux trous aux parties supérieur et inférieur de la porte aux emplacements indiqués.
- Taladrar dos agujeros a las partes superior e inferior de la puerta a las ubicaciones indicadas.

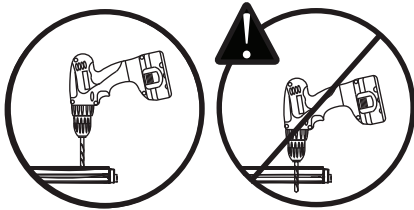
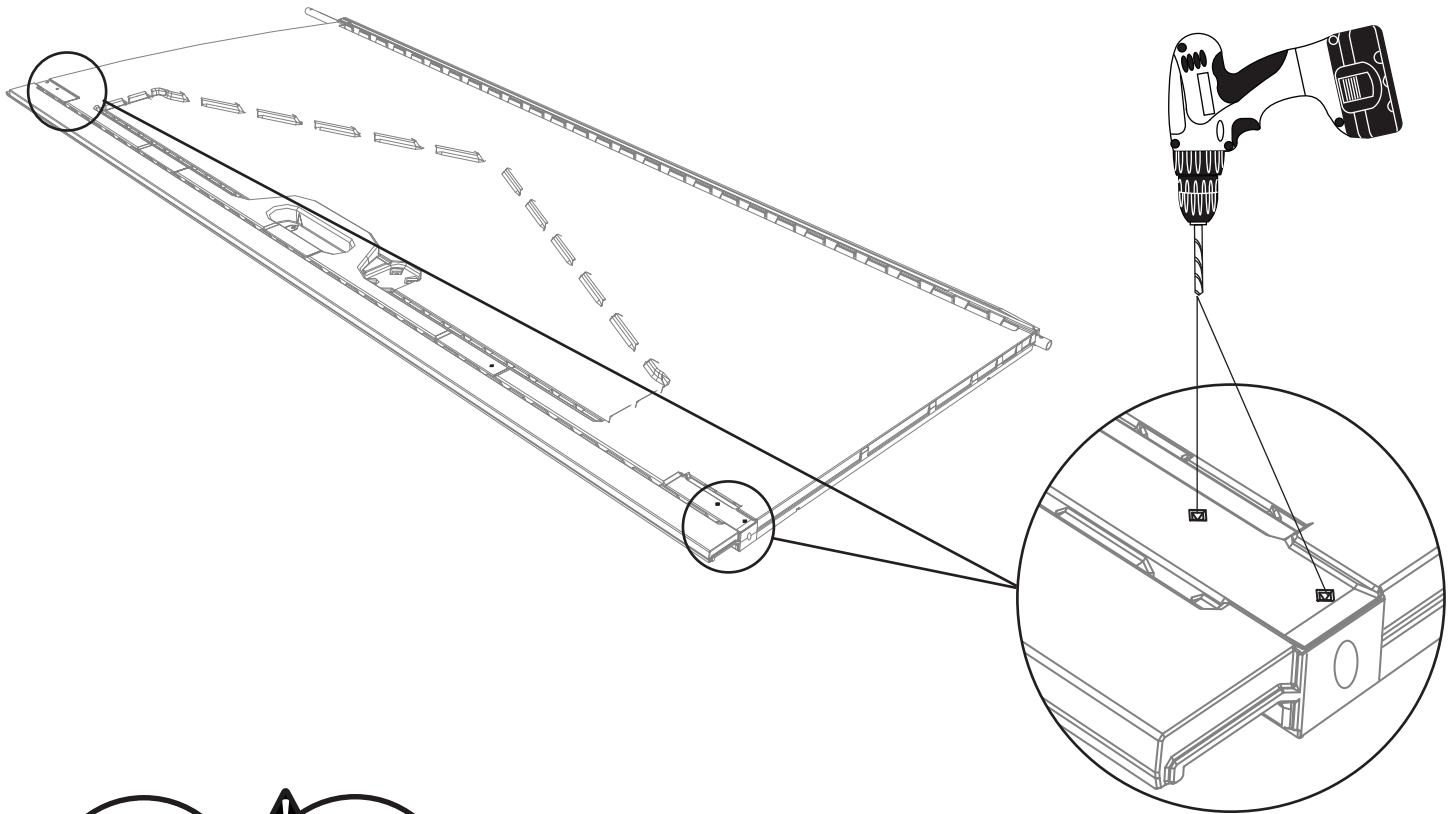

► SECTION 4 (CONTINUED) / SECTION 4 (SUITE) / SECCIÓN 4 (CONTINUACIÓN)

TOOLS AND HARDWARE REQUIRED / OUTILS ET QUINCAILLERIE REQUIS / INSTRUMENTAL Y HERRAJE REQUERIDOS

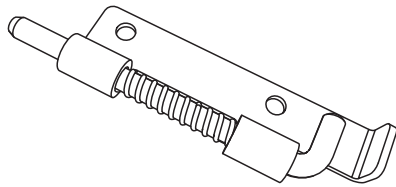

DGS (x1) (Top / Supérieur / Superior)

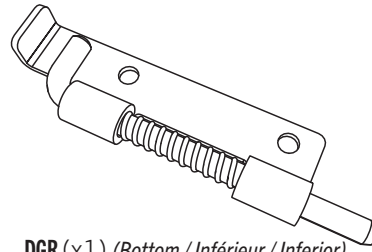

DGR (x1) (Bottom / Inférieur / Inferior)

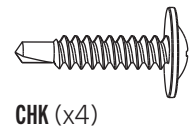

CHK (x4)

4.6

- Secure the two **deadbolts (DGR & DGS)** to the top and bottom of the door using the hardware provided. The deadbolts should move freely. If they do not, loosen the screws a tad.
- Bien attacher les deux **verrous (DGR et DGS)** aux parties supérieure et inférieure de la porte en utilisant la quincaillerie incluse. Les verrous doivent faire glisser librement. Si non, desserrer un peu les vis.
- Sujetar bien los **cerrojos (DGR y DGS)** a las partes superior e inferior de la puerta usando el herraje incluido. Los cerrojos deben mover libremente. Si no, aflojar un poco los tornillos.

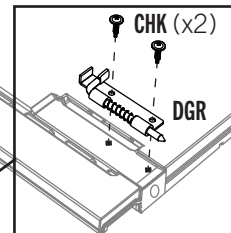
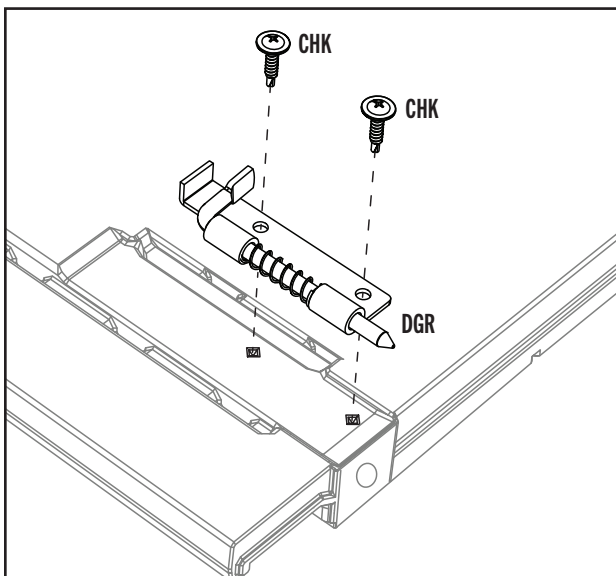
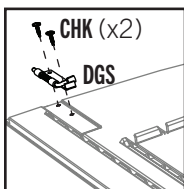

► SECTION 4 (CONTINUED) / SECTION 4 (SUITE) / SECCIÓN 4 (CONTINUACIÓN)

TOOLS AND HARDWARE REQUIRED / OUTILS ET QUINCAILLERIE REQUIS / INSTRUMENTAL Y HERRAJE REQUERIDOS

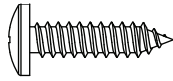

ADW (x1)

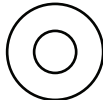

AEE (x3)

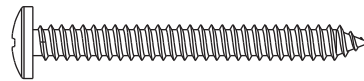

BYZ (x2)

4.7

- Attach the **handle pieces (BYR & BYS)** using the hardware provided.
- Attacher les **pièces de la poignée (BYR et BYS)** à l'aide de la quincaillerie incluse.
- Sujetar las **piezas del picaporte (BYR y BYS)** usando el herraje incluido.

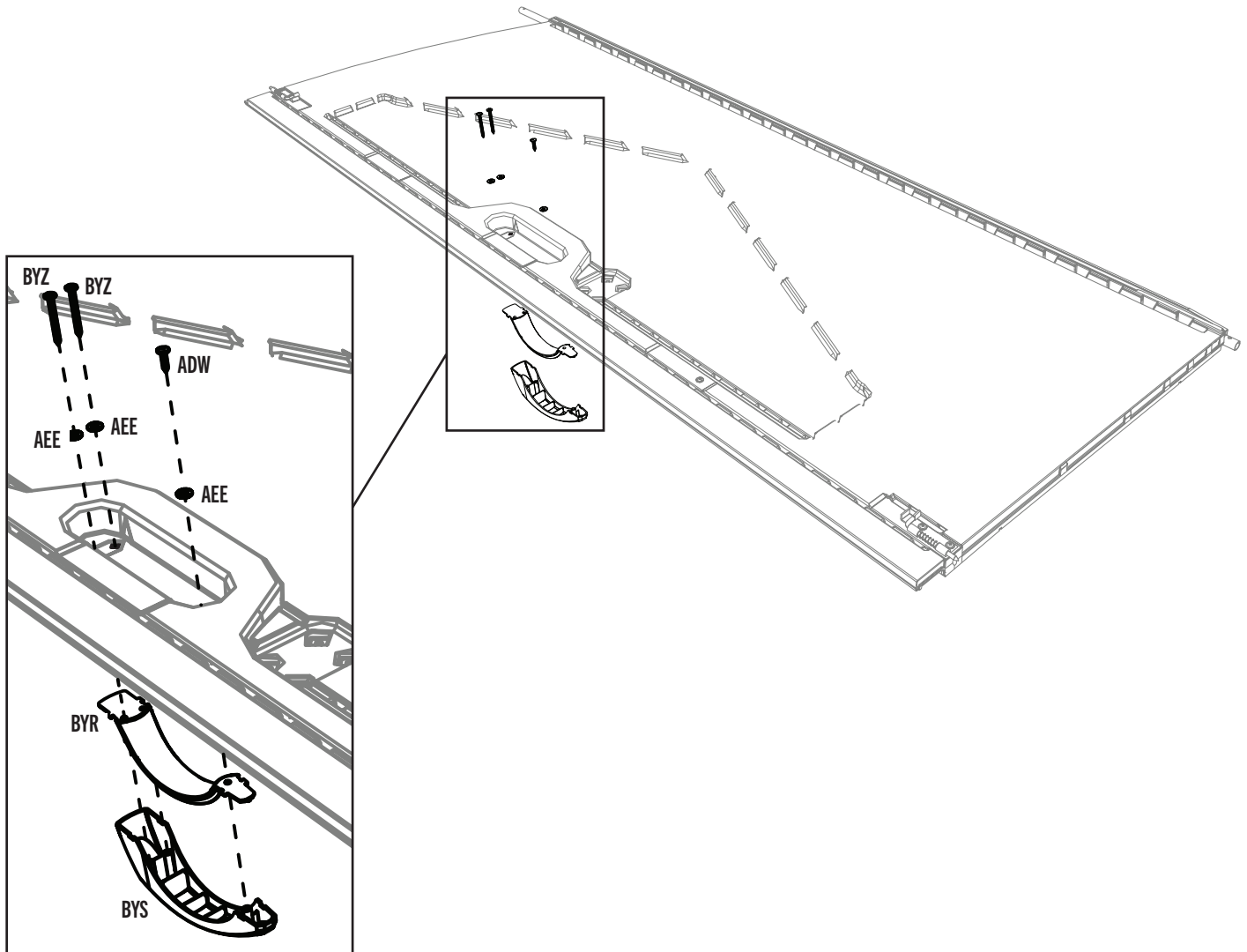

5

RIGHT DOOR ASSEMBLY / ASSEMBLAGE DE LA PORTE DROITE / ENSAMBLAJE DE LA PUERTA DERECHA



HARDWARE REQUIRED / QUINCAILLERIE REQUISE / HERRAJE REQUERIDO

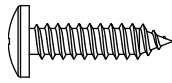

ADW (x1)

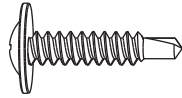

CHK (x1)

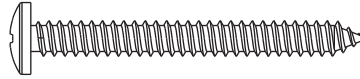

BYZ (x2)

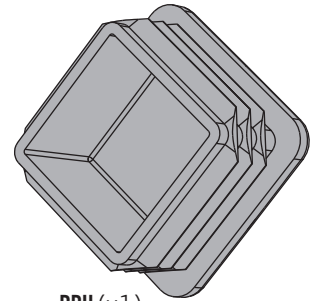

BBH (x1)

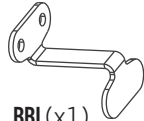

BBI (x1)

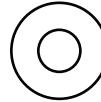

AEE (x1)



PARTS REQUIRED / PIÈCES REQUISES / PIEZAS REQUERIDAS

Metal parts / Pièces en métal / Piezas de metal

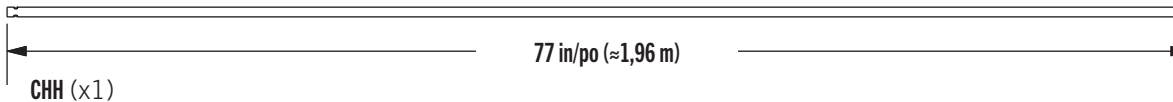

CHH (x1)

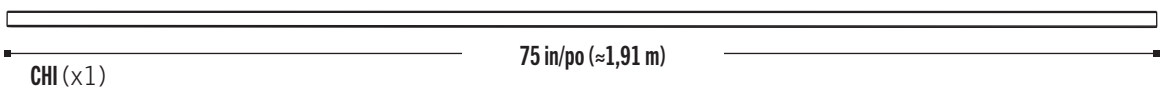

CHI (x1)

Plastic parts / Pièces en plastique / Piezas de plástico

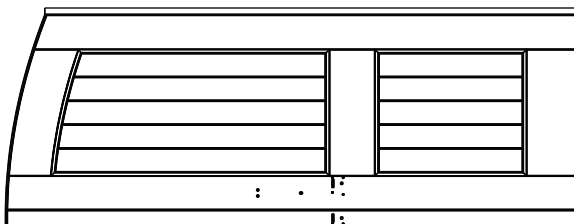

AGZ (x1)

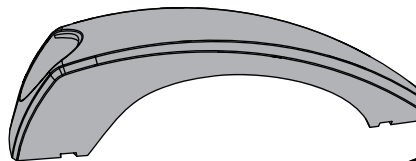

BYS (x1)



BYR (x1)



TOOLS REQUIRED / OUTILS REQUIS / INSTRUMENTAL REQUERIDO

(Not included—unless otherwise indicated*) / (Non inclus — sauf indication contraire*) / (No incluido, salvo indicación contraria*)

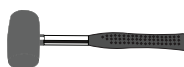

ARA (x1)*

► SECTION 5 (CONTINUED) / SECTION 5 (SUITE) / SECCIÓN 5 (CONTINUACIÓN)

TOOLS AND HARDWARE REQUIRED / OUTILS ET QUINCAILLERIE REQUIS / INSTRUMENTAL Y HERRAJE REQUERIDOS



- In case of any trouble with this section, scan the QR code below to view a video on its assembly.
- En cas de problème avec cette section, scanner le QR code en dessous pour voir une vidéo de l'assemblage.
- En caso de problemas con esta sección, escanear el código QR debajo para ver un video del ensamblaje.



<http://go.lifetime.com/7x7shed-section5>

5.1

- Slide a **hinge tube (CHH)** down into the hole in the **right door (AGZ)**.
- Faire glisser le **tube d'articulation (CHH)** dans le trou dans la **porte droite (AGZ)**.
- Deslizar el **tubo de articulación (CHH)** en el agujero en la **puerta derecha (AGZ)**.

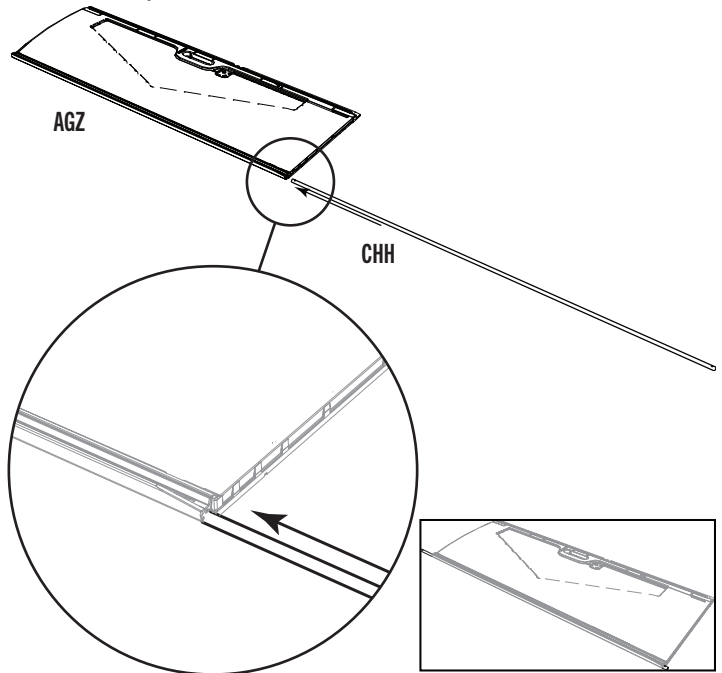

5.2

- Insert a **square tube (CHI)** into the square hole in the bottom of the door until the end hangs out about 1/2" (≈ 12 mm).
- Insérer un **tube carré (CHI)** dans le trou carré au fond de la port jusqu'à ce que l'extrémité dépasse à peu près 1/2" (≈ 12 mm).
- Insertar un **tubo cuadrado (CHI)** en el agujero cuadrado al fondo de la puerta hasta que el extremo extienda unos 1/2" (≈ 12 mm).

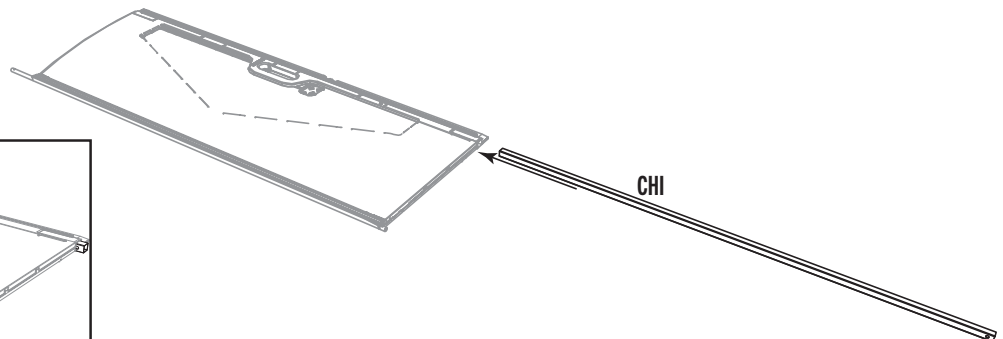
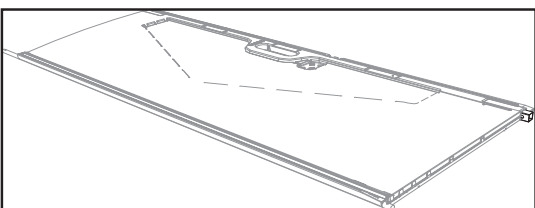

► SECTION 5 (CONTINUED) / SECTION 5 (SUITE) / SECCIÓN 5 (CONTINUACIÓN)

TOOLS AND HARDWARE REQUIRED / OUTILS ET QUINCAILLERIE REQUIS / INSTRUMENTAL Y HERRAJE REQUERIDOS



ARA (x1)

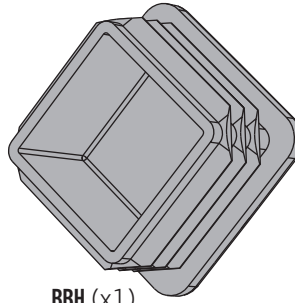

BBH (x1)

5.3

- Insert an **end cap (BBH)** into the end of the **square tube (CHI)**. Gently, finish inserting the tube until it's flush with the bottom of the door.
- Insérer un **capuchon (BBH)** dans l'extrémité du **tube carré (CHI)**. Insérer gentiment le tube jusqu'à ce qu'il soit aligné avec le fond de la porte.
- Insertar un **tapón (BBH)** en el extremo del **tubo cuadrado (CHI)**. Insertar ligeramente el tubo hasta que esté alineado con el fondo de la puerta.

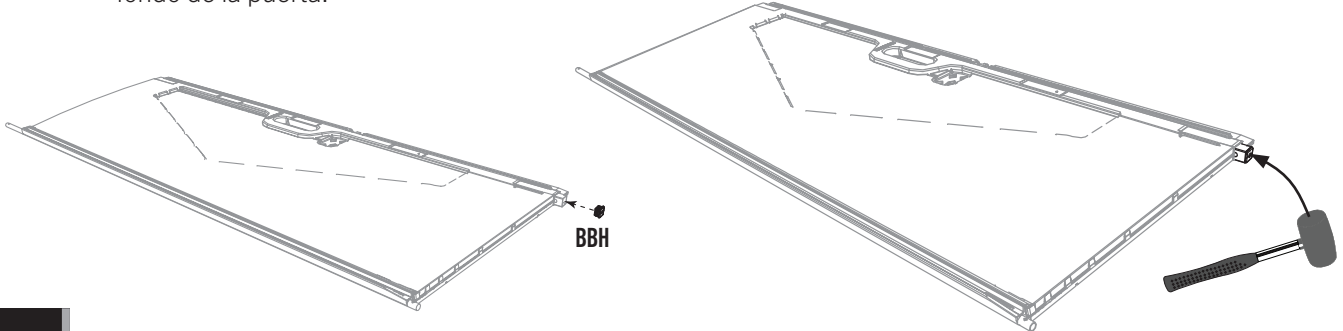

5.4

- Using an **1/8" (≈3 mm) drill bit (ARA)**, drill through the door and into the square tube. Do not drill all the way through the door—just into the tube.
- En utilisant un **foret de 1/8" (≈3 mm) (ARA)**, percer la porte et le tube carré. Ne pas percer complètement à travers la porte — juste dans le tube.
- Usando una **broca de 1/8" (≈3 mm) (ARA)**, taladrar la puerta y el tubo cuadrado. No taladrar por la puerta entera, sólo al tubo.

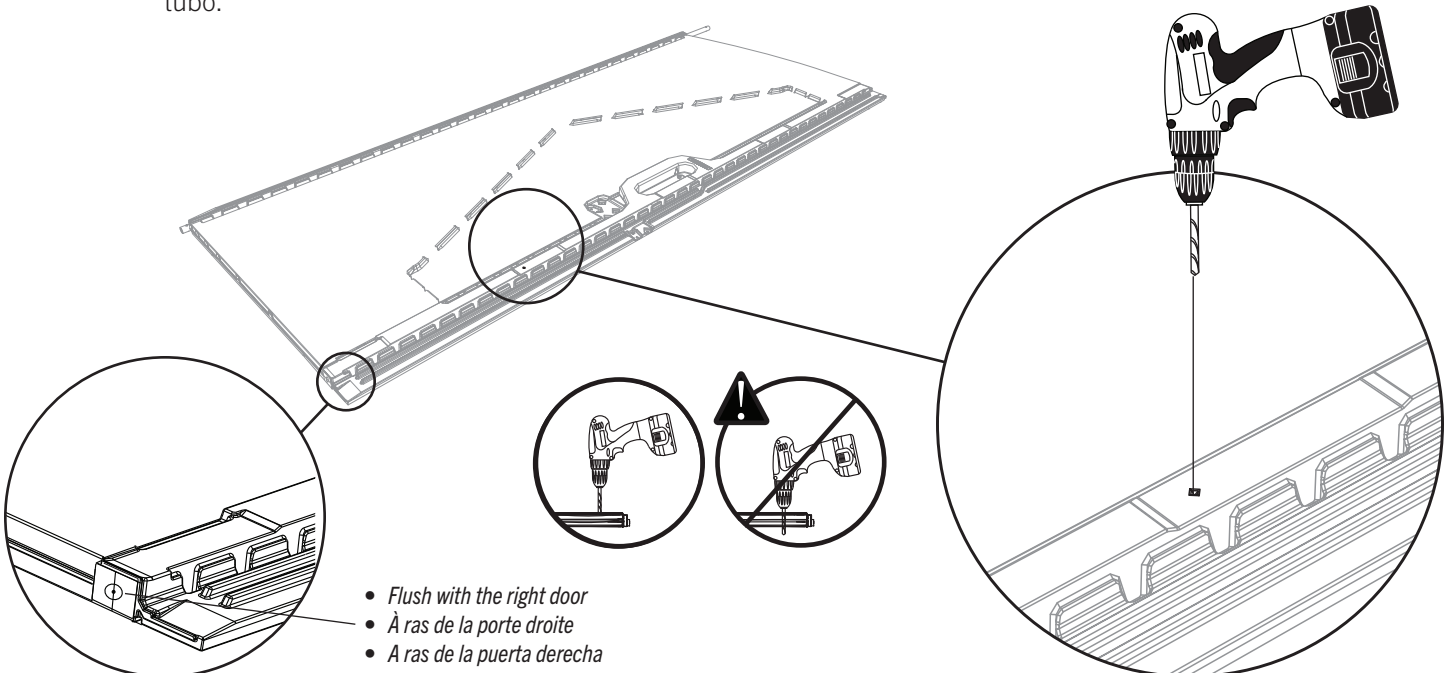

SECTION 5 (CONTINUED) / SECTION 5 (SUITE) / SECCIÓN 5 (CONTINUACIÓN)

TOOLS AND HARDWARE REQUIRED / OUTILS ET QUINCAILLERIE REQUIS / INSTRUMENTAL Y HERRAJE REQUERIDOS

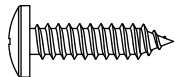

ADW (x1)

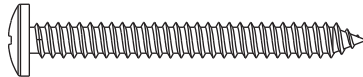

BYZ (x2)

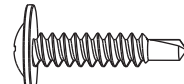

CHK (x1)

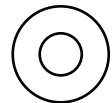

AEE (x1)

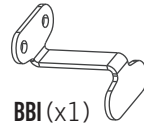

BBI (x1)

5.5

- Once the end cap is flush with the bottom of the door, insert **self-drilling/self-tapping screw (CHK)** into the door panel at the location shown to hold the square tube in place.
- Une fois que le capuchon soit à ras du bord inférieur de la porte, insérer une **vis autoperceuse/autotaraudeuse (CHK)** dans la porte à l'emplacement indiqué afin de maintenir le tube carré en place.
- Una vez que el tapón esté a ras del borde inferior de la puerta, insertar un tornillo **auto-perforante/auto-roscante (CHK)**.

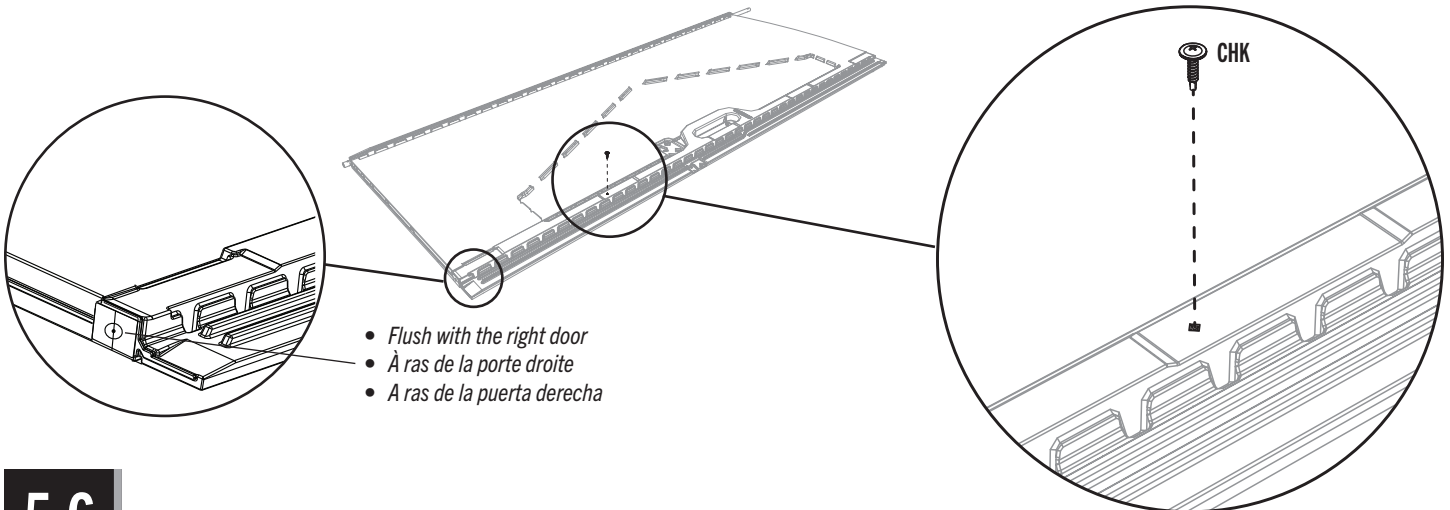

5.6

- Attach the **handle pieces (BYR & BYS)** using the hardware provided.
- Attacher les **pièces de la poignée (BYR et BYS)** à l'aide de la quincaillerie incluse.
- Sujetar las **piezas del picaporte (BYR y BYS)** usando el herraje incluido.

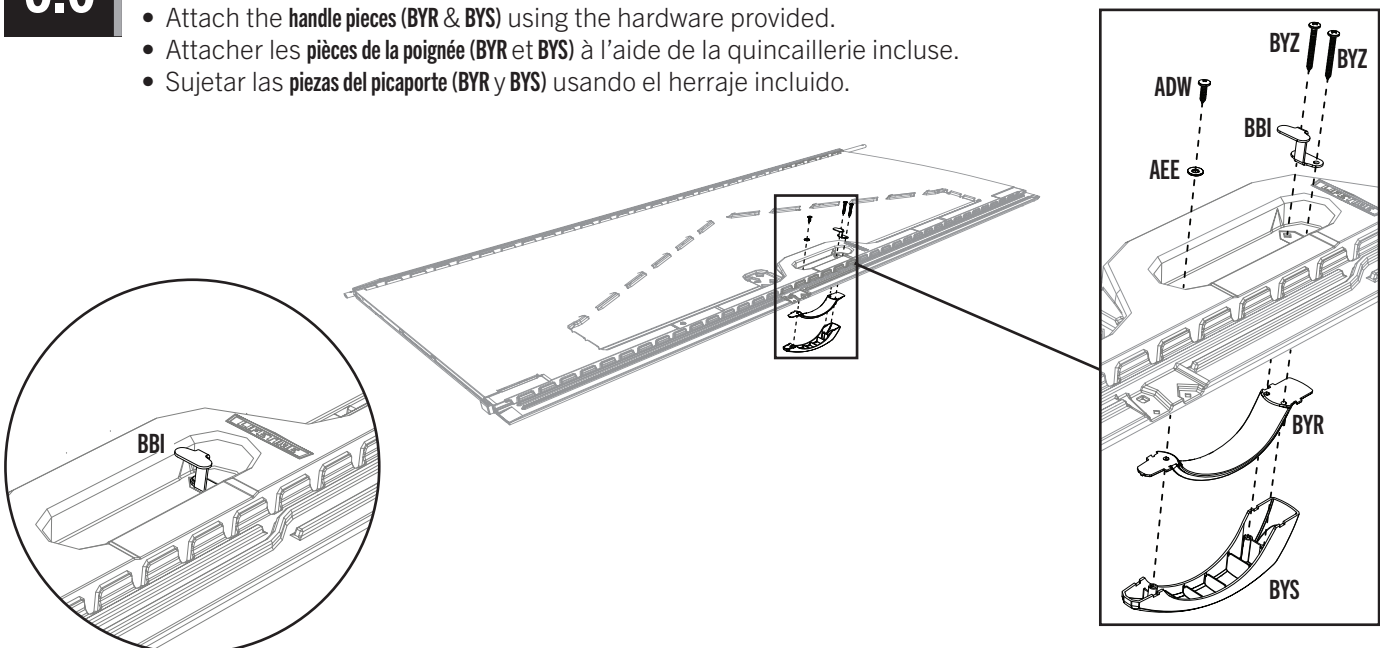

6

FLOOR ASSEMBLY / ASSEMBLAGE DU PLANCHER / ENSAMBLAJE DEL PISO



HARDWARE REQUIRED / QUINCAILLERIE REQUISE / HERRAJE REQUERIDO

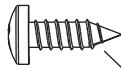

BQC (x4)

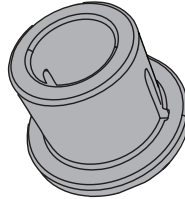

AHO (x2)



ADC (x1)



- These screws do not anchor the floor; they only hold the panels together.
- Ces vis n'ancrent pas le plancher ; ils ne servent que pour attacher les panneaux les uns aux autres.
- Estos tornillos no anclan el piso; sirven sólo para sujetar los paneles los unos a los otros.



PARTS REQUIRED / PIÈCES REQUISES / PIEZAS REQUERIDAS

Plastic parts / Pièces en plastique / Piezas de plástico

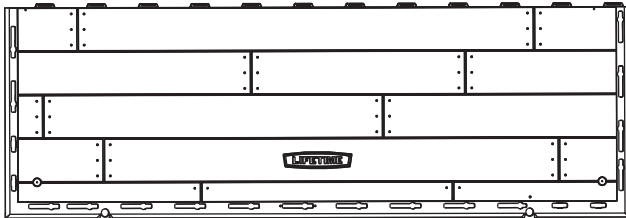

AGR (x2)



TOOLS REQUIRED / OUTILS REQUIS / INSTRUMENTAL REQUERIDO

(Not included—unless otherwise indicated*) / (Non inclus — sauf indication contraire*) / (No incluido, salvo indicación contraria*)



► SECTION 6 (CONTINUED) / SECTION 6 (SUITE) / SECCIÓN 6 (CONTINUACIÓN)

TOOLS AND HARDWARE REQUIRED / OUTILS ET QUINCAILLERIE REQUIS / INSTRUMENTAL Y HERRAJE REQUERIDOS



- If you have trouble with this section, follow the code below to view a video on the assembly in this section.
- Si vous avez des problèmes avec cette section, suivez le code en bas pour voir un vidéo sur l'assemblage dans cette section.
- Si tiene problemas con esta sección, siga el código debajo para ver un video sobre el ensamble en esta sección.

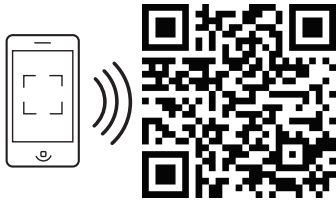

<http://go.lifetime.com/7x4floorassembly>

6.1

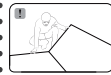

- Hold an **outer floor panel (AGR)** at an angle and slide the tabs along the edge underneath the other **outer floor panel (AGR)**. The tabs interlock. Lay the panel down flat.
- Poser un **panneau de plancher extérieur (AGR)** à un angle, faire glisser les languettes le long du bord au-dessus de l'autre **panneau de plancher extérieur (AGR)**. Les languettes s'enclenchent les uns les autres. Étendre-le par terre.
- Colocar un **panel de piso exterior (AGR)** a un ángulo, y deslizar las lengüetas a lo largo del borde debajo el otro **panel de piso exterior (AGR)**. Las lengüetas se entrelazan las unas con las otras. Aplanar el panel.

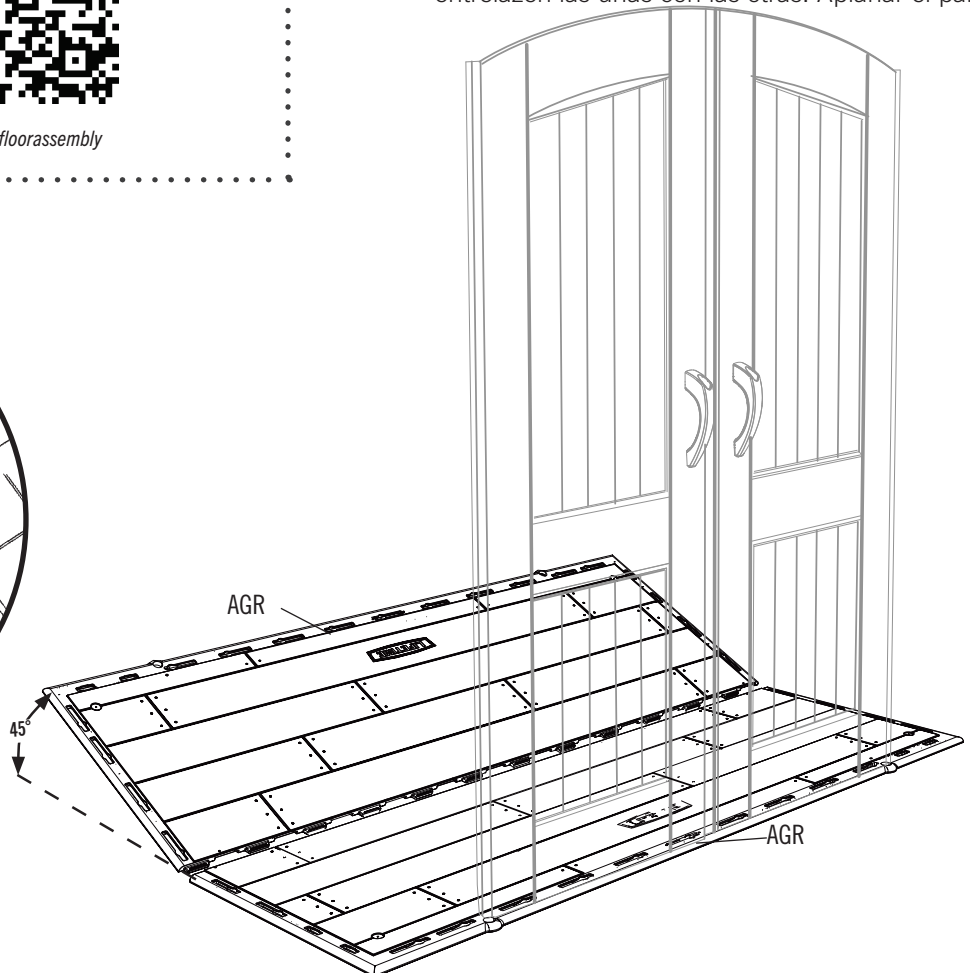
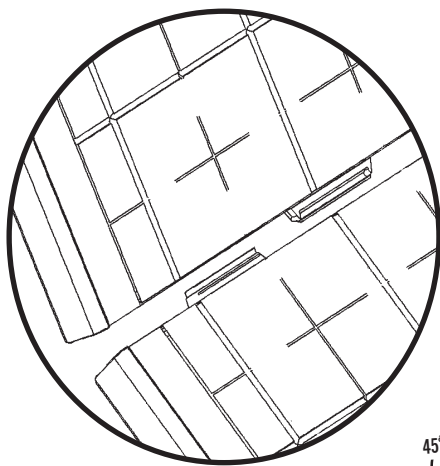

► SECTION 6 (CONTINUED) / SECTION 6 (SUITE) / SECCIÓN 6 (CONTINUACIÓN)

TOOLS AND HARDWARE REQUIRED / OUTILS ET QUINCAILLERIE REQUIS / INSTRUMENTAL Y HERRAJE REQUERIDOS

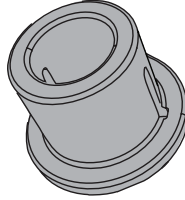

AHO (x2)

6.2

- Decide on which end you would like to install your doors. Insert **bushings (AHO)** through the holes in the floor. **The slit in the bushings should face the front of the shed.**
- Choisir l'extrémité où vous désirez installer les portes. Insérez les **bagues (AHO)** à travers les trous dans le plancher. **La fente dans la bague doit donner sur le bord avant de l'abri.**
- Decida en cuál borde le gustaría instalar las puertas. Introducir los **casquillos (AHO)** a través de los agujeros en el piso. **La rendija en el casquillo debe dar hacia el borde delantero de la caseta.**

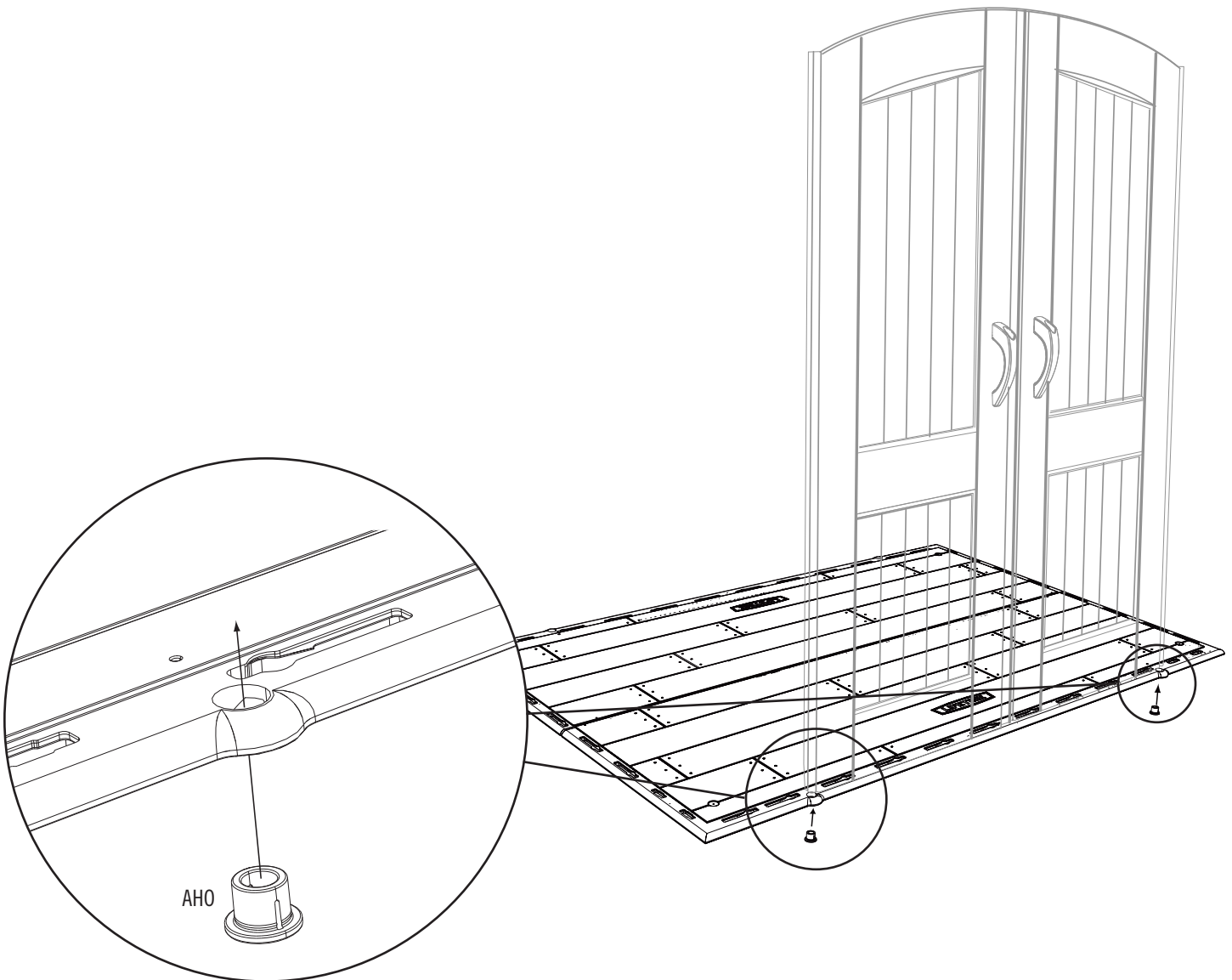

► SECTION 6 (CONTINUED) / SECTION 6 (SUITE) / SECCIÓN 6 (CONTINUACIÓN)

TOOLS AND HARDWARE REQUIRED / OUTILS ET QUINCAILLERIE REQUIS / INSTRUMENTAL Y HERRAJE REQUERIDOS

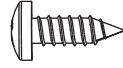

BQC (x4)

6.3



- Insert the **screws (BQC)** through the divots in the floor panels and into the tabs of the adjacent floor panel. (The divots are near the seams of the floor panels.) **These screws do not anchor the floor; they only hold the panels together.**
- Insérer les **vis (BQC)** à travers les marques dans les panneaux de plancher et dans les languettes du panneaux de plancher contigu. (Les marques se trouvent près des jonctions des panneaux de plancher.) **Ces vis n'ancrent pas le plancher; ils ne servent que pour attacher les panneaux les uns avec les autres.**
- Insertar los **tornillos (BQC)** a través de las marcas en los paneles de piso y dentro de las lengüetas de los paneles de piso adyacentes. (Se encuentran las marcas cerca de las juntas de los paneles de piso.) **Estos tornillos no anclan el piso; sirven sólo para sujetar los paneles los unos con los otros.**

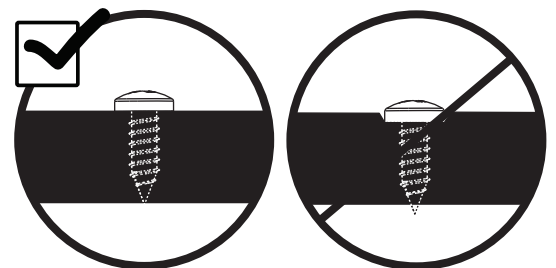
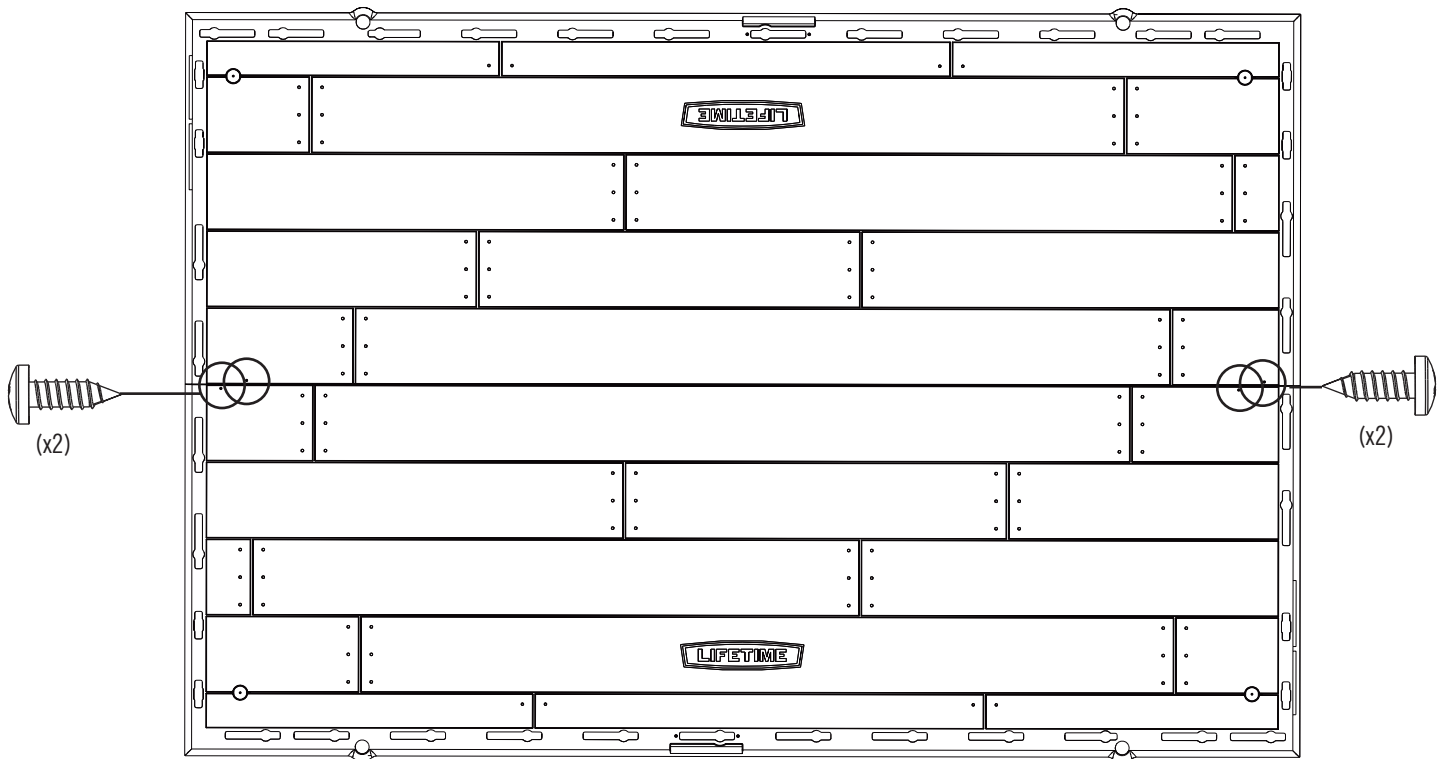

7

WALL ASSEMBLY / ASSEMBLAGE DES MURS / ENSAMBLAJE DE LOS MUROS



HARDWARE REQUIRED / QUINCAILLERIE REQUISE / HERRAJE REQUERIDO

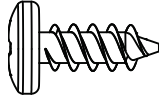

ADZ (x55)

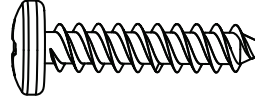

ADV (x6)



PARTS REQUIRED / PIÈCES REQUISES / PIEZAS REQUERIDAS

Metal parts / Pièces en métal / Piezas de metal



AFM (x4)

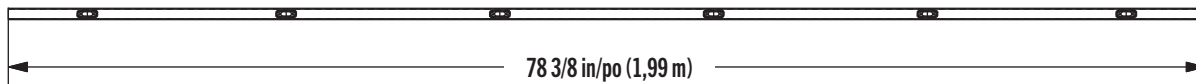

BXX (x1)



Plastic parts / Pièces en plastique / Piezas de plástico

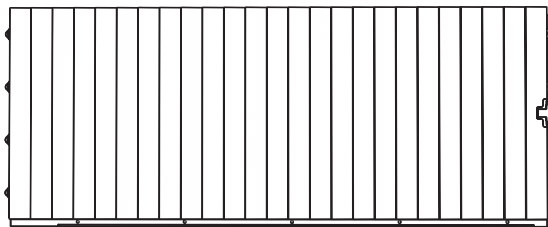

AHD (x4)

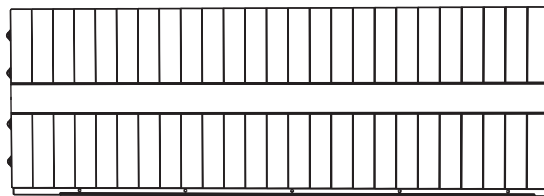

AGL (x4)

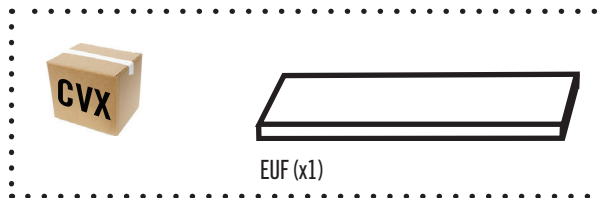

EUF (x1)



TOOLS REQUIRED / OUTILS REQUIS / INSTRUMENTAL REQUERIDO

(Not included—unless otherwise indicated*) / (Non inclus — sauf indication contraire*) / (No incluido, salvo indicación contraria*)



► SECTION 7 (CONTINUED) / SECTION 7 (SUITE) / SECCIÓN 7 (CONTINUACIÓN)

TOOLS AND HARDWARE REQUIRED / OUTILS ET QUINCAILLERIE REQUIS / INSTRUMENTAL Y HERRAJE REQUERIDOS

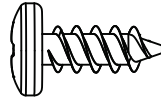

ADZ (x20)



- If you have trouble with this section, follow the code below to view a video on the assembly in this section.
- Si vous avez des problèmes avec cette section, suivez le code en bas pour voir un vidéo sur l'assemblage dans cette section.
- Si tiene problemas con esta sección, siga el código debajo para ver un video sobre el ensamble en esta sección.



<http://go.lifetime.com/7x4wallassembly>

7.1



- Attach a wall support channel (AFM) to a wall panel (AHD) using five (5) screws (ADZ). Repeat this step for all wall panels (AHD).
- Attacher un canal de support mural (AFM) au panneau mural (AHD) à l'aide de cinq (5) vis (ADZ). Répéter cette étape pour tous les panneaux muraux (AHD).
- Sujetar un canal de soporte mural (AFM) al panel mural (AHD) usando cinco (5) tornillos (ADZ). Repetir este paso para todos los paneles murales (AHD).

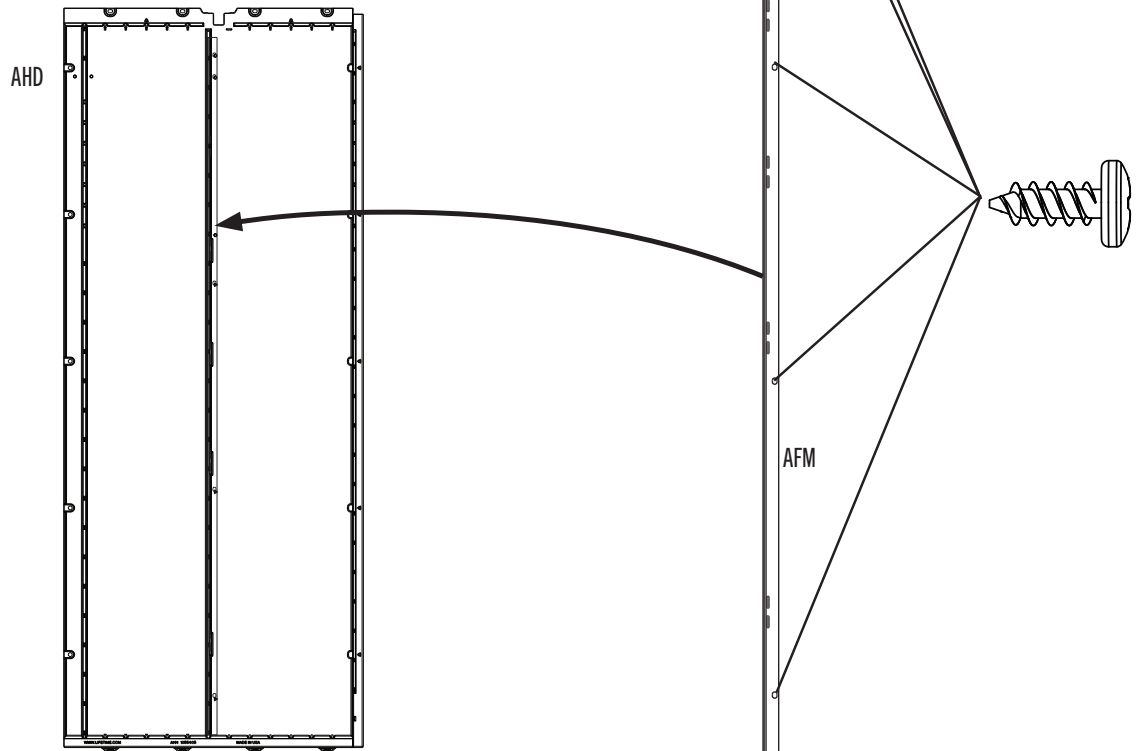

► SECTION 7 (CONTINUED) / SECTION 7 (SUITE) / SECCIÓN 7 (CONTINUACIÓN)

TOOLS AND HARDWARE REQUIRED / OUTILS ET QUINCAILLERIE REQUIS / INSTRUMENTAL Y HERRAJE REQUERIDOS



7.2

- Insert the two left-most tabs at the bottom of the **corner panel (AGL)** into the two right-most slots along the front edge of the floor.
- Insérer les deux languettes gauches au bord inférieur du **panneau angulaire (AGL)** dans les deux rainures droites le long du bord avant du plancher.
- Introducir las lengüetas al borde inferior del **panel angular (AGL)** en las ranuras a lo largo del borde delantero del piso.

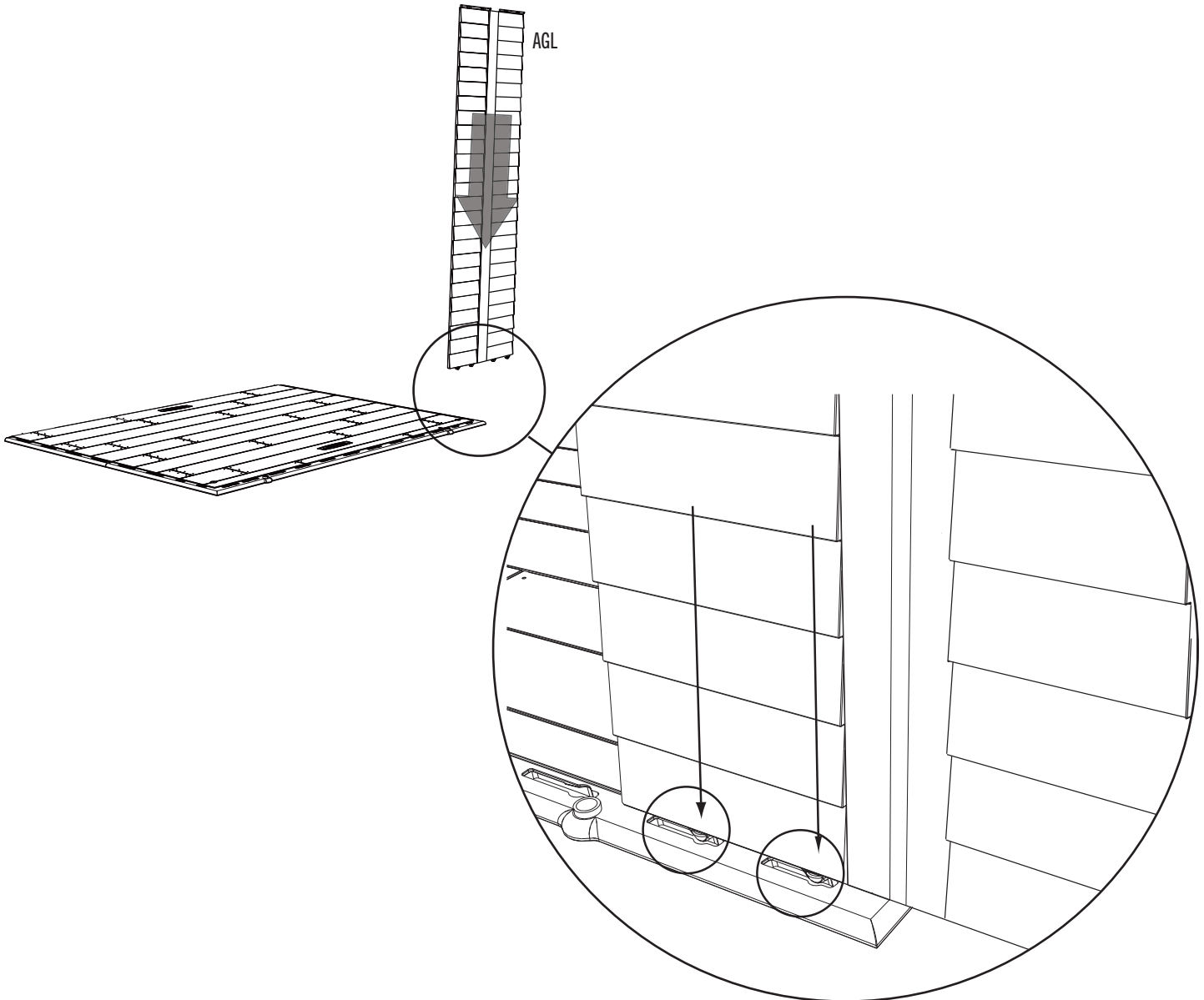

► SECTION 7 (CONTINUED) / SECTION 7 (SUITE) / SECCIÓN 7 (CONTINUACIÓN)

TOOLS AND HARDWARE REQUIRED / OUTILS ET QUINCAILLERIE REQUIS / INSTRUMENTAL Y HERRAJE REQUERIDOS



7.3

- Slide the corner panel to the left.
- Faire glisser le panneau angulaire à gauche.
- Deslizar el panel angular a la izquierda.



- *If the bushings are in the way, temporarily remove them to insert the wall panel.*
- *Si les bagues interfèrent avec l'installation, les retirer temporairement pour pouvoir insérer le panneau mural.*
- *Si los casquillos interfieren con la instalación, retirarlos temporalmente para poder insertar el panel mural.*

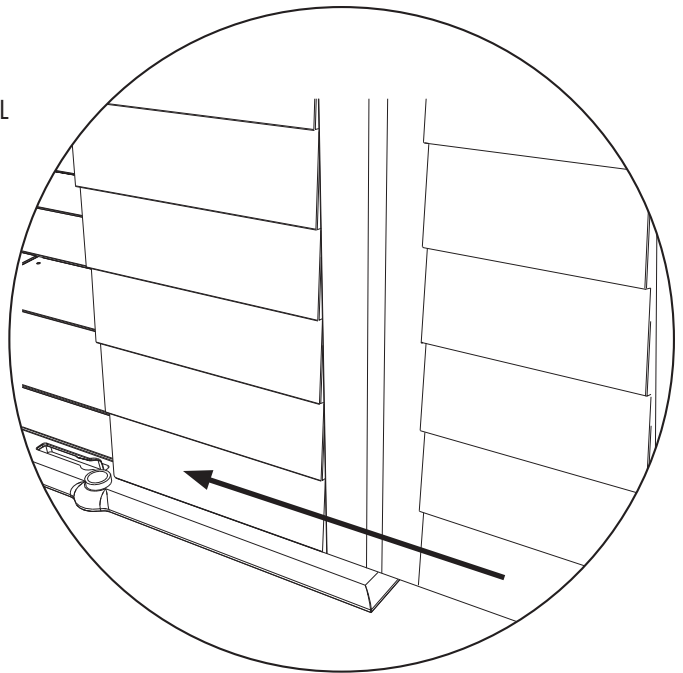
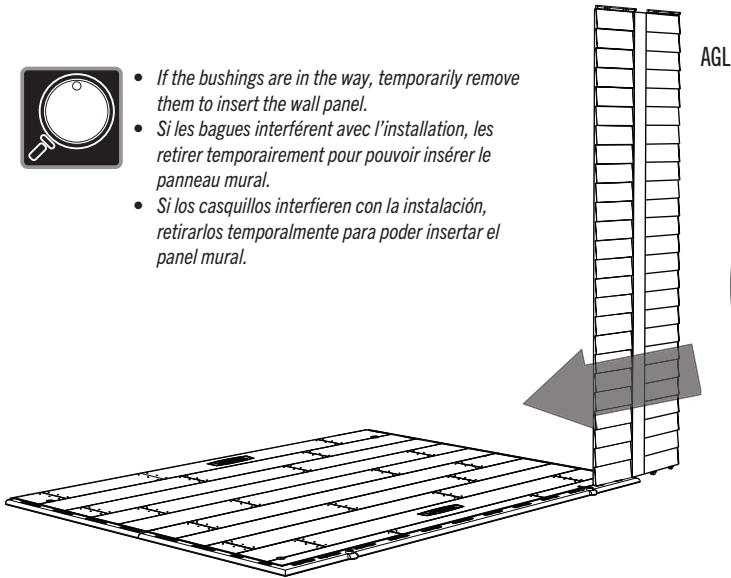

7.4

- Bend the corner panel.
- Plier le panneau angulaire.
- Doblar el panel angular.

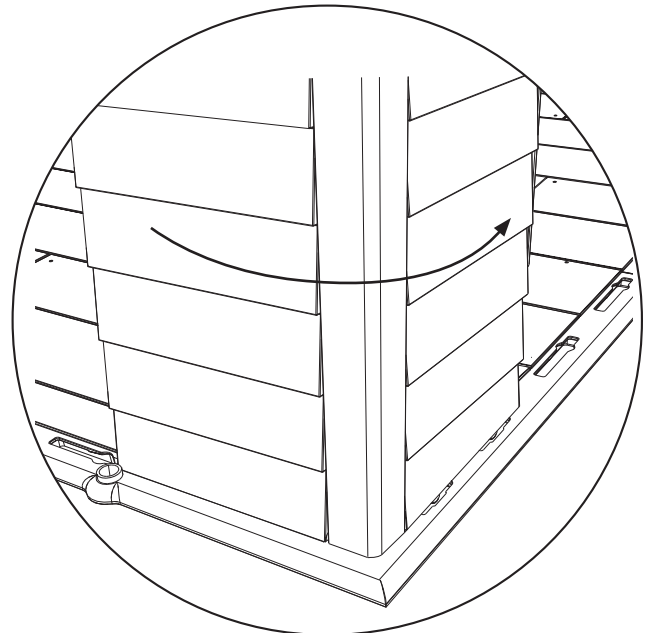

► SECTION 7 (CONTINUED) / SECTION 7 (SUITE) / SECCIÓN 7 (CONTINUACIÓN)

TOOLS AND HARDWARE REQUIRED / OUTILS ET QUINCAILLERIE REQUIS / INSTRUMENTAL Y HERRAJE REQUERIDOS



7.5

- Pull down on the panel to insert the remaining tabs. To help with insertion, place the **plastic block (EUF)** under the floor panel directly under the tab being inserted. You should hear a “click” when the tab pops into place. **Repeat this step for the second tab.**
- Tirer le panneau pour insérer les languettes restantes. Pour aider avec l'assemblage, mettre le **bloque en plastique (EUF)** sous le panneau de plancher directement sous la languette à insérer. **Répéter ce processus pour la deuxième languette.**
- Tirar para abajo el panel para insertar las lengüetas restantes. Para ayudar con el ensamble, deslizar el **bloque de plástico (EUF)** debajo el panel de piso directamente debajo la lengüeta que quiere insertar. Se escucha un «clic» cuando la lengüeta se encaja en su lugar. **Repetir este proceso para la segunda lengüeta.**

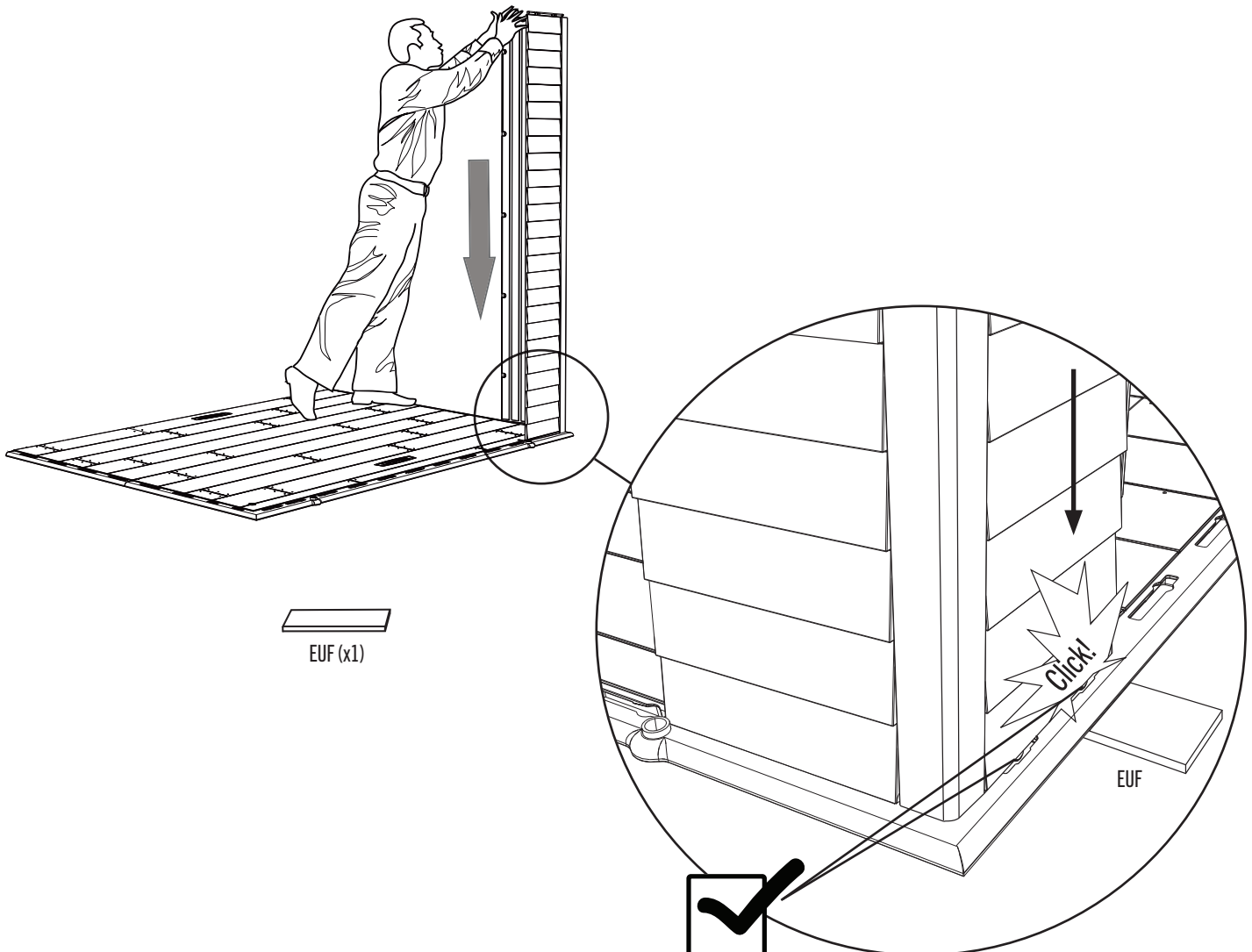

► SECTION 7 (CONTINUED) / SECTION 7 (SUITE) / SECCIÓN 7 (CONTINUACIÓN)

TOOLS AND HARDWARE REQUIRED / OUTILS ET QUINCAILLERIE REQUIS / INSTRUMENTAL Y HERRAJE REQUERIDOS

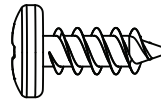

ADZ (x5)

7.6

- Insert the tabs of the **wall panel (AHD)** into the slots along the right edge of the floor. Slide the panel toward the corner panel. Secure the panels to one another using five (5) **screws (ADZ)**. The attachment points may have a thin membrane that the screws will puncture.
- Insérer les languettes du **panneau mural (AHD)** dans les fentes le long du bord droit du plancher. Faire glisser le panneau vers le panneau angulaire. Attacher les panneaux l'un à l'autre à l'aide de cinq (5) **vis (ADZ)**. Les points de fixation peuvent avoir une fine membrane que les vis perceront.
- Insertar las lengüetas del **panel mural (AHD)** dentro de las ranuras a lo largo del borde derecho del piso. Deslizar el panel hacia el panel angular. Sujetar los paneles los unos a los otros usando cinco (5) **tornillos (ADZ)**. Los puntos de fijación pueden tener una membrana delgada que los tornillos perforarán.

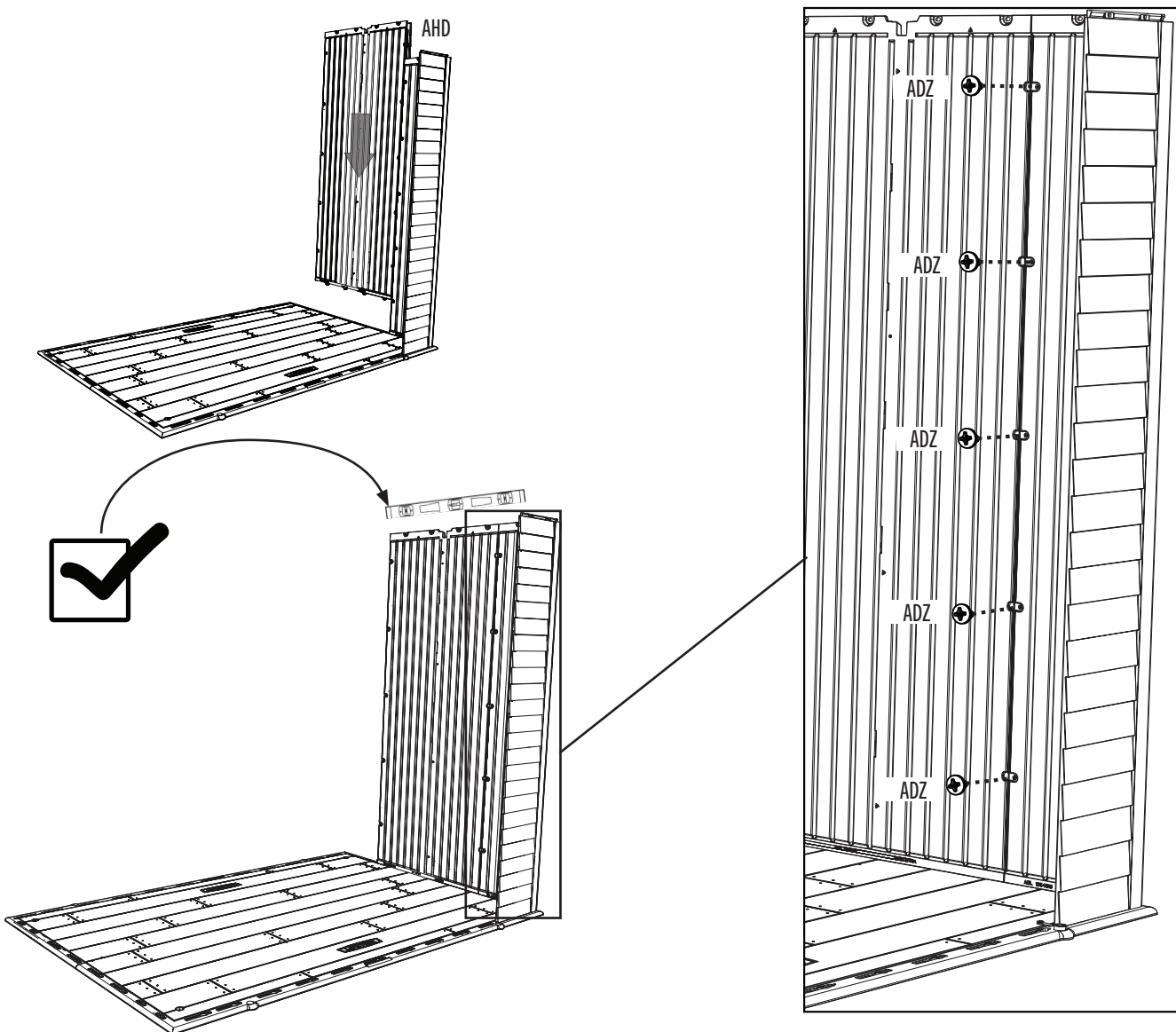

► SECTION 7 (CONTINUED) / SECTION 7 (SUITE) / SECCIÓN 7 (CONTINUACIÓN)

TOOLS AND HARDWARE REQUIRED / OUTILS ET QUINCAILLERIE REQUIS / INSTRUMENTAL Y HERRAJE REQUERIDOS

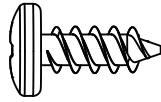

ADZ (x15)

7.7

- Attach this **corner panel (AGL)** in the same manner you did the previous corner panel.
- Attacher ce **panneau angulaire (AGL)** de la même façon que le panneau angulaire précédent.
- Sujetar este **panel angular (AGL)** de la misma manera que el panel angular anterior.

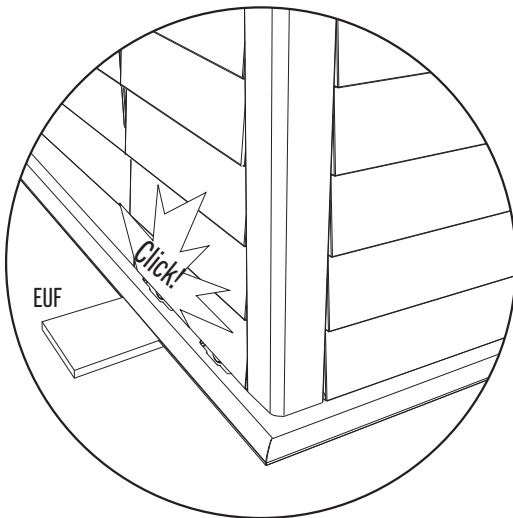

EUF (x1)

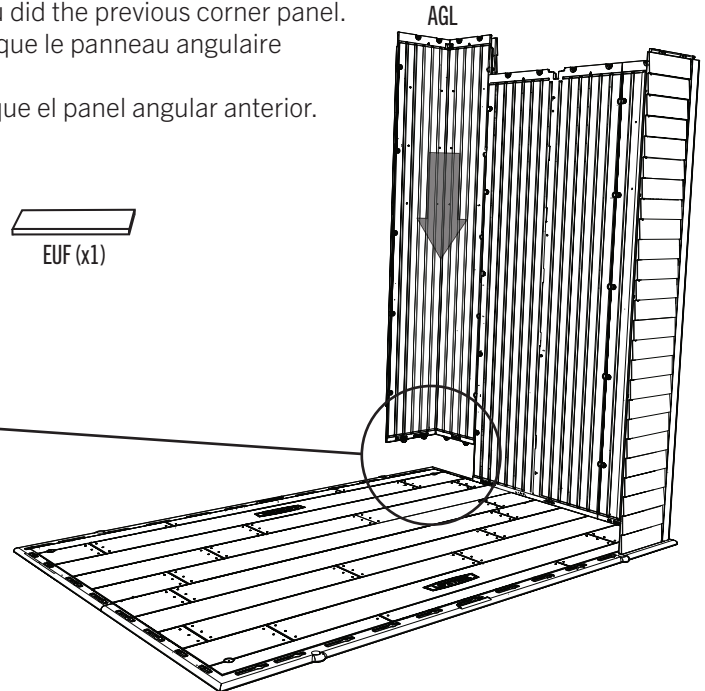

7.8

- Insert the tabs of two (2) **wall panels (AHD)** into the slots along the rear edge of the floor. Slide the panels toward the corner panel. Secure the panels to one another using five (5) **screws (ADZ)** for each panel.
- Insérer les languettes des deux (2) **panneaux muraux (AHD)** dans les fentes le long du bord arrière du plancher. Faire glisser les panneaux vers le panneau angulaire. Attacher les panneaux les un aux autres à l'aide de cinq (5) **vis (ADZ)** pour chaque panneau.
- Insertar las lengüetas de dos (2) **paneles murales (AHD)** dentro de las ranuras a lo largo del borde trasero del piso. Deslizar los paneles hacia el panel angular. Sujetar los paneles los unos a los otros usando cinco (5) **tornillos (ADZ)** para cada panel.

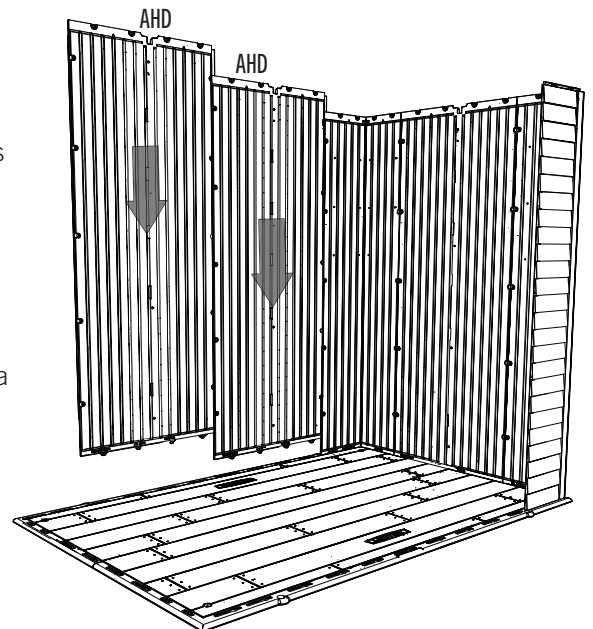

► SECTION 7 (CONTINUED) / SECTION 7 (SUITE) / SECCIÓN 7 (CONTINUACIÓN)

TOOLS AND HARDWARE REQUIRED / OUTILS ET QUINCAILLERIE REQUIS / INSTRUMENTAL Y HERRAJE REQUERIDOS

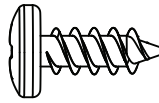

ADZ (x10)

7.9

- Attach this **corner panel (AGL)** in the same manner you did the previous corner panel.
- Attacher ce **panneau angulaire (AGL)** de la même façon que le panneau angulaire précédent.
- Sujetar este **panel angular (AGL)** de la misma manera que el panel angular anterior.

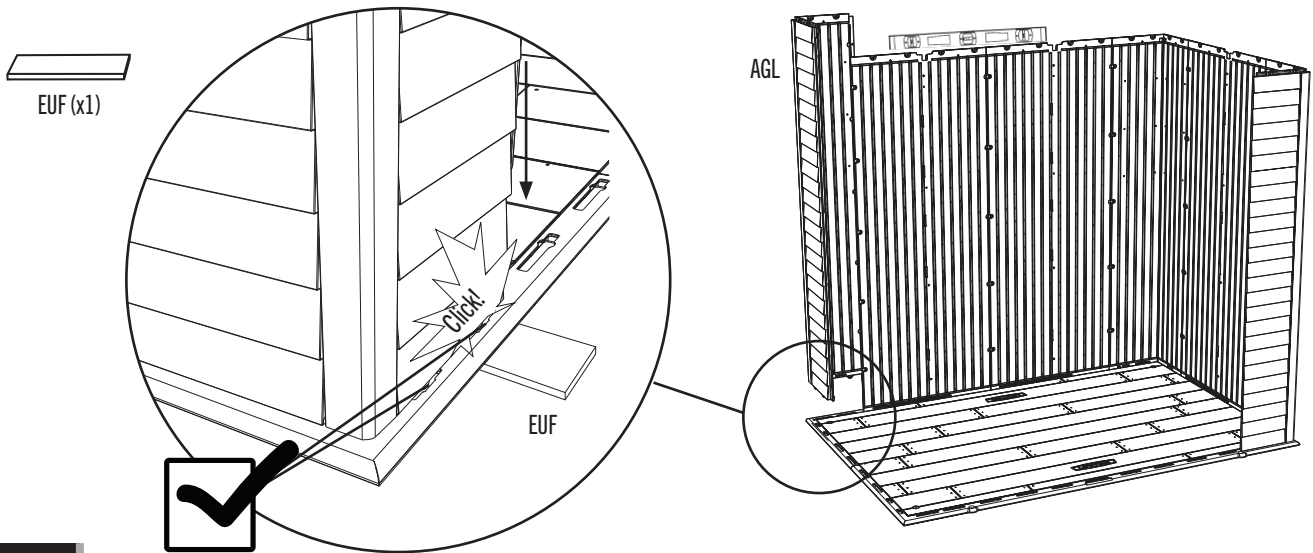

7.10

- Insert the tabs of the **wall panel (AHD)** into the slots along the left edge of the floor. Slide the panel toward the corner panel. Secure the panels to one another using five (5) **screws (ADZ)**.
- Insérer les languettes du **panneau mural (AHD)** dans les fentes le long du bord gauche du plancher. Faire glisser le panneau vers le panneau angulaire. Attacher les panneaux l'un à l'autre à l'aide de cinq (5) **vis (ADZ)**.
- Insertar las lengüetas del **panel mural (AHD)** dentro de las ranuras a lo largo del borde izquierdo del piso. Deslizar el panel hacia el panel angular. Sujetar los paneles los unos a los otros usando cinco (5) **tornillos (ADZ)**.

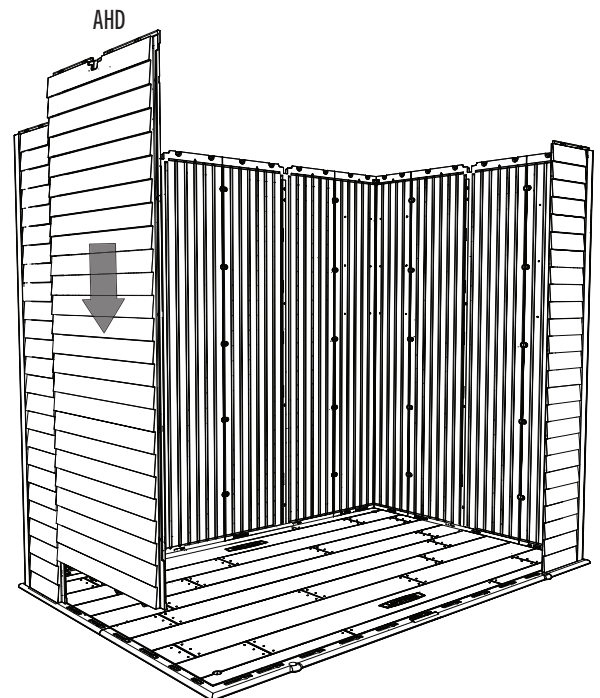

► SECTION 7 (CONTINUED) / SECTION 7 (SUITE) / SECCIÓN 7 (CONTINUACIÓN)

TOOLS AND HARDWARE REQUIRED / OUTILS ET QUINCAILLERIE REQUIS / INSTRUMENTAL Y HERRAJE REQUERIDOS

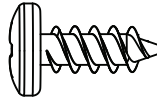

ADZ (x5)

7.11

- Attach this **corner panel (AGL)** in the same manner you did the previous corner panel.
- Attacher ce **panneau angulaire (AGL)** de la même façon que le panneau angulaire précédent.
- Sujetar este **panel angular (AGL)** de la misma manera que el panel angular anterior.



- If the bushings are in the way, temporarily remove them to insert the wall panel.
- Si les bagues interfèrent avec l'installation, les retirer temporairement pour pouvoir insérer le panneau mural.
- Si los casquillos interfieren con la instalación, retirarlos temporalmente para poder insertar el panel mural.

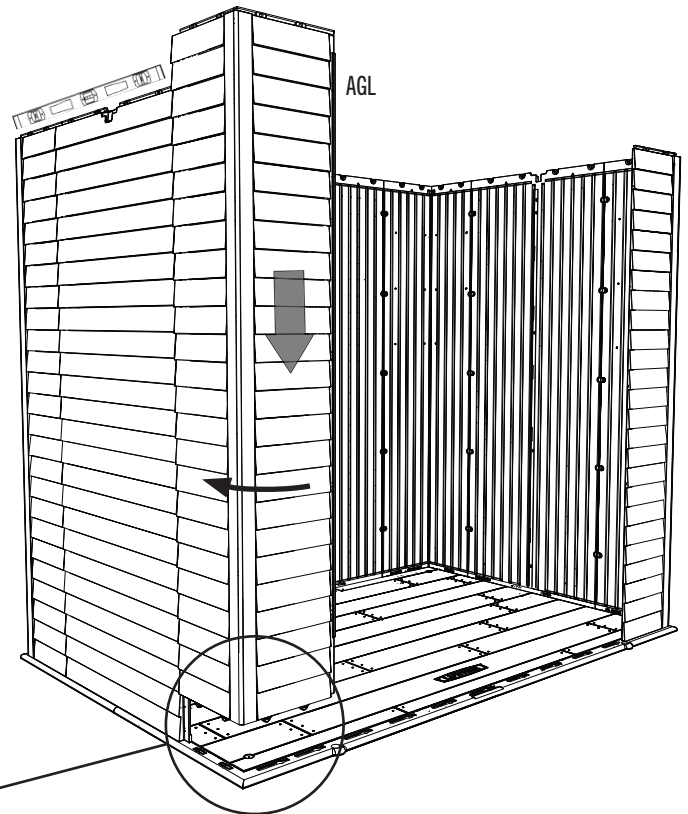

EU (x1)

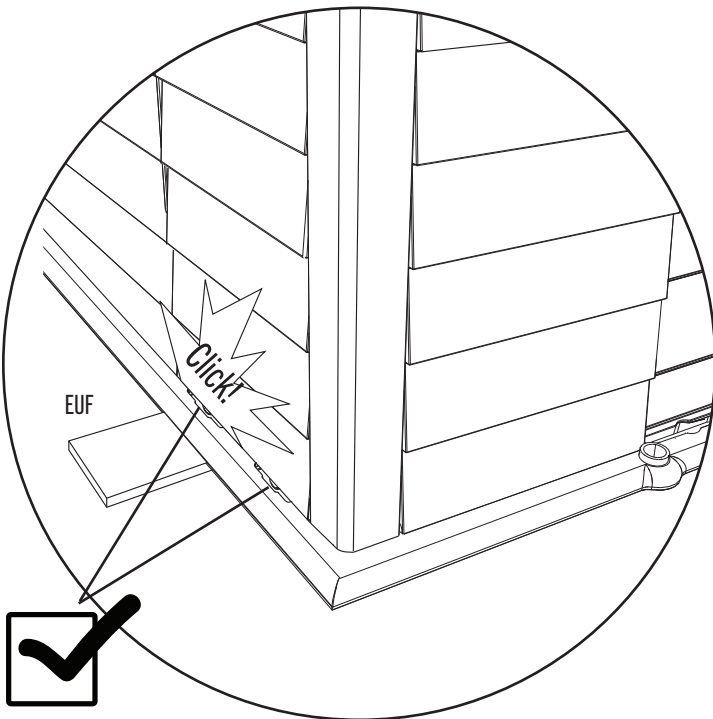

► SECTION 7 (CONTINUED) / SECTION 7 (SUITE) / SECCIÓN 7 (CONTINUACIÓN)

TOOLS AND HARDWARE REQUIRED / OUTILS ET QUINCAILLERIE REQUIS / INSTRUMENTAL Y HERRAJE REQUERIDOS

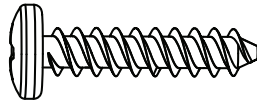

ADV (x6)

7.12

- Use a hand screwdriver to attach the **wall support tube (BXX)** to the top of the rear wall panels using six (6) **screws (ADV)**.
- Utiliser un tournevis manuel pour attacher le **tube de support mural (BXX)** au bord supérieur des panneaux muraux arrière à l'aide de six (6) **vis (ADV)**.
- Usar un destornillador manual para sujetar el **tubo de soporte mural (BXX)** al borde superior de los paneles murales traseros usando seis (6) **tornillos (ADV)**.

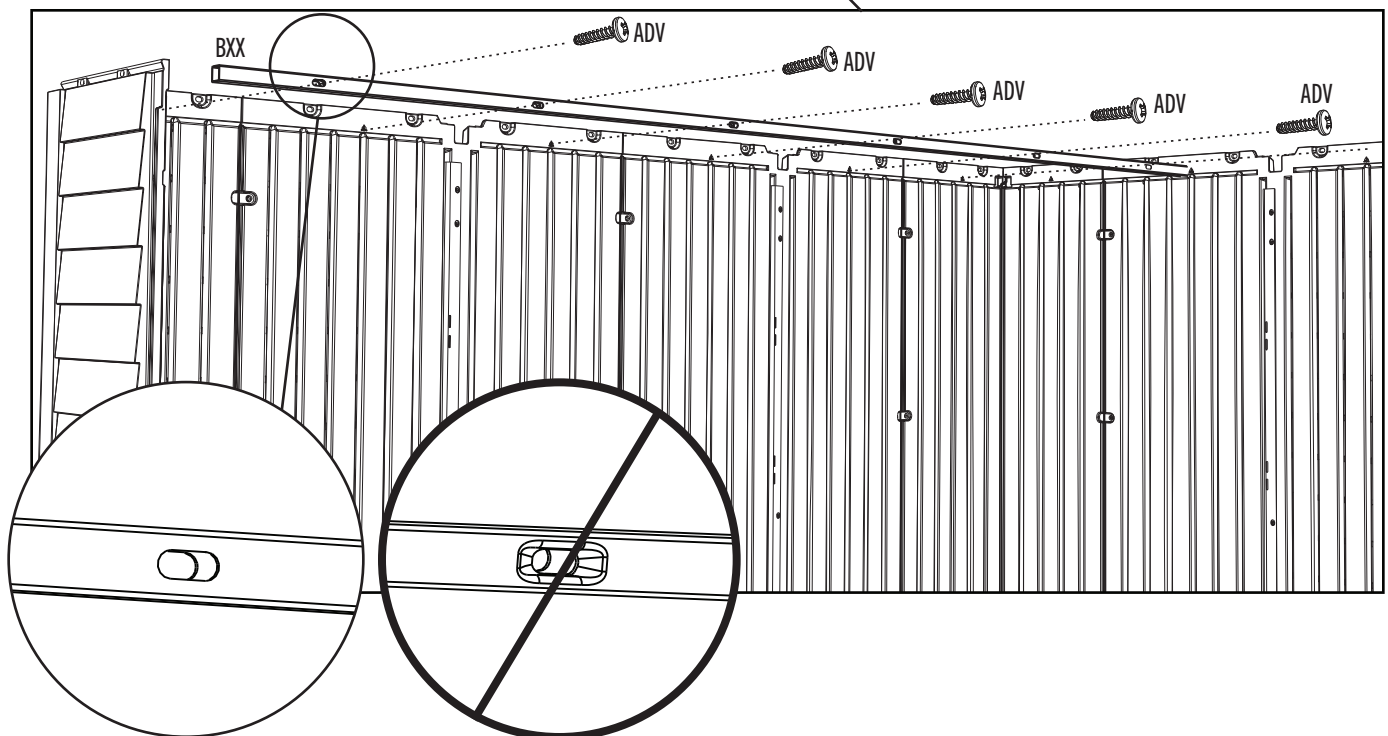
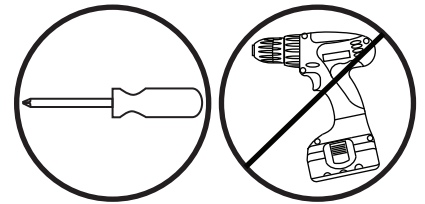
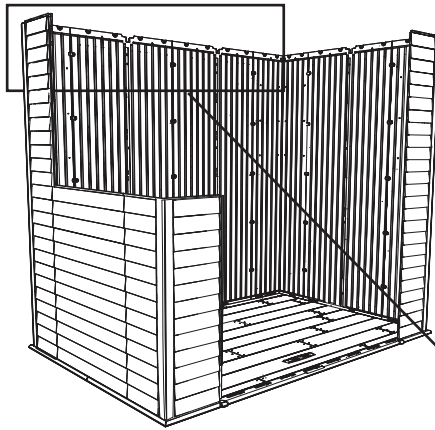

8

SHELF INSTALLATION / INSTALLATION DU RAYONNAGE / INSTALACIÓN DE LA ESTANTERÍA



HARDWARE REQUIRED / QUINCAILLERIE REQUISE / HERRAJE REQUERIDO

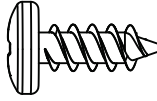

ADZ (x12)



PARTS REQUIRED / PIÈCES REQUISES / PIEZAS REQUERIDAS

Metal parts / Pièces en métal / Piezas de metal



AIY (x2)

.....
Plastic parts / Pièces en plastique / Piezas de plástico

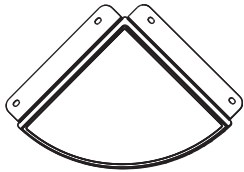

AFZ (x2)



AFS (x1)



TOOLS REQUIRED / OUTILS REQUIS / INSTRUMENTAL REQUERIDO

(Not included—unless otherwise indicated) / (Non inclus — sauf indication contraire*) / (No incluido, salvo indicación contraria*)*



► SECTION 8 (CONTINUED) / SECTION 8 (SUITE) / SECCIÓN 8 (CONTINUACIÓN)

TOOLS AND HARDWARE REQUIRED / OUTILS ET QUINCAILLERIE REQUIS / INSTRUMENTAL Y HERRAJE REQUERIDOS



- In case of problems with this section, follow the code below to view a video on the assembly in this section.
- En cas de problèmes avec cette section, suivre le code en bas pour voir un vidéo sur l'assemblage dans cette section.
- En caso de problemas con esta sección, seguir el código debajo para ver un vídeo sobre el ensamble en esta sección.



<http://go.lifetime.com/7shelving>

8.1

- Insert two (2) shelf brackets (AIY) into the slots in two adjacent wall/shelf support channels. **The shelf brackets must be at the same height.**
- Insérer deux (2) équerres (AIY) dans les fentes dans deux canaux de support pour les murs/étagères adjacents. **Les équerres doivent être à la même hauteur.**
- Insertar dos (2) escuadras (AIY) en las ranuras en dos canales de soporte para las paredes/estantes adyacentes. **Las escuadras deben estar a la misma altura.**

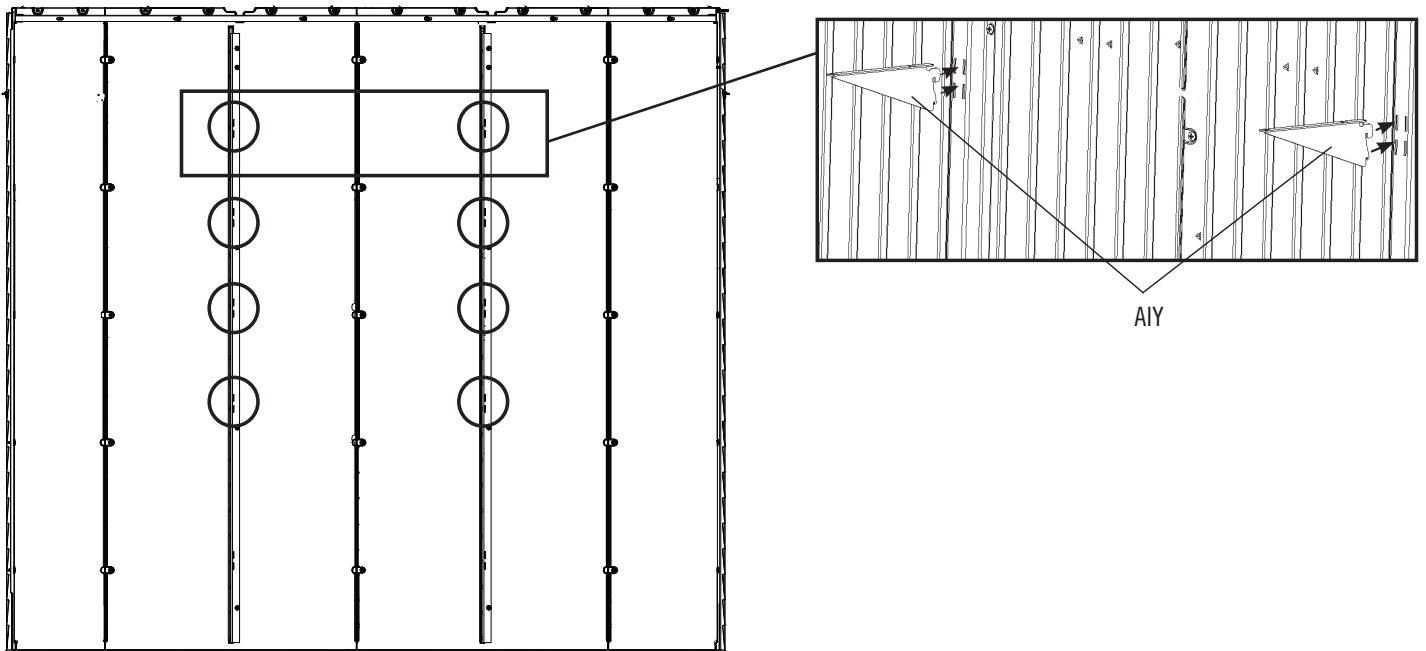

► SECTION 8 (CONTINUED) / SECTION 8 (SUITE) / SECCIÓN 8 (CONTINUACIÓN)

TOOLS AND HARDWARE REQUIRED / OUTILS ET QUINCAILLERIE REQUIS / INSTRUMENTAL Y HERRAJE REQUERIDOS

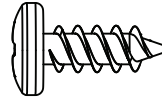

ADZ (x12)

8.2

- Attach the **shelf (AFS)** to the brackets using four (4) **screws (ADZ)**.
- Attacher l'**étagère (AFS)** aux équerres à l'aide de quatre (4) **vis (ADZ)**.
- Sujetar el **estante (AFS)** a las escuadras usando cuatro (4) **tornillos (ADZ)**.

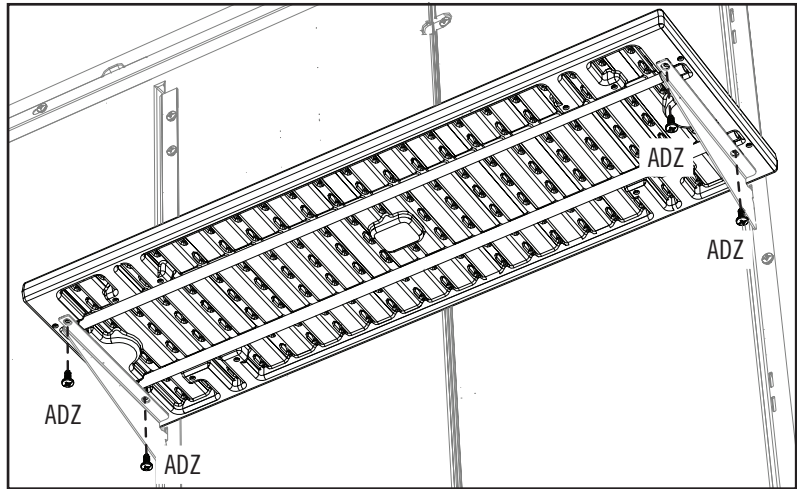



↓ **30 lb. (14 kg)**

8.3

- Fold up the flaps of a **corner shelf (AFZ)** and place it in any corner of the shed. Align the holes in the flaps with those in the corner wall panel. Secure with four (4) **screws (ADZ)**. **Repeat the previous step for the second corner shelf.**
- Plier les bords de l'**étagère angulaire (AFZ)** et mettez-le dans any corner de l'abri. Aligner les trous dans les bords avec ceux dans le panneau angulaire. Attacher-le au mur à l'aide de quatre (4) **vis (ADZ)**. **Répéter l'étape précédente pour la deuxième étagère angulaire.**
- Doblar los bordes del **estante angular (AFZ)** y colocarlo en cualquier esquina de la caseta. Alinear los agujeros en los bordes con los agujeros en el panel angular. Sujetar el estante usando cuatro (4) **tornillos (ADZ)**. **Repetir paso anterior para el segundo estante angular.**

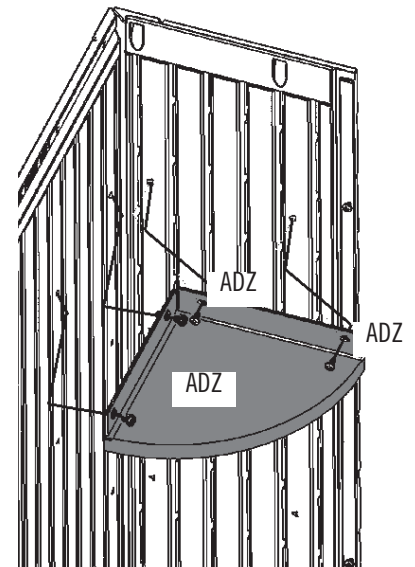
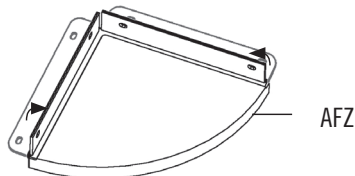
↓ **10 lb. (4,5 kg)**



9

DOOR & ENTRY GABLE INSTALLATION / INSTALLATION DES PORTES ET LE PIGNON D'ENTRÉE / INSTALACIÓN DE LAS PUERTAS Y LA FACHADA DE ENTRADA



HARDWARE REQUIRED / QUINCAILLERIE REQUISE / HERRAJE REQUERIDO

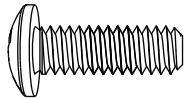

BFY (x5)

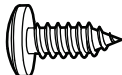

ADX (x2)

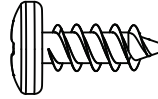

ADZ (x11)



ADJ (x5)

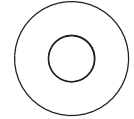

BXZ (x16)



AHP (x2)



BYM (x1)



PARTS REQUIRED / PIÈCES REQUISES / PIEZAS REQUERIDAS

Metal parts / Pièces en plastique / Piezas de plástico

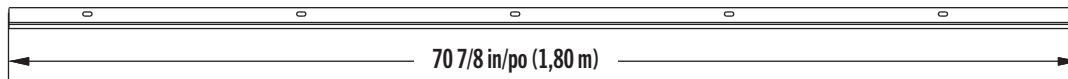

BYA (x1)

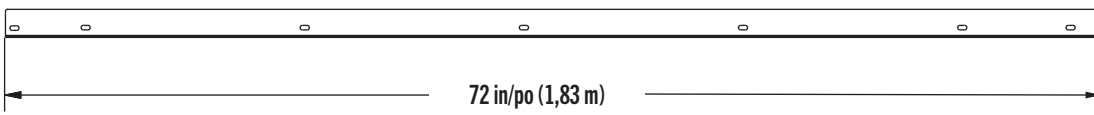

BYB (x1)

Plastic parts / Pièces en plastique / Piezas de plástico



AGF (x1)

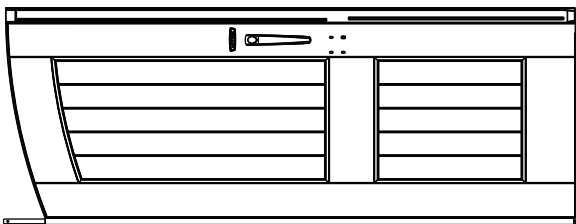

AGO (x1)

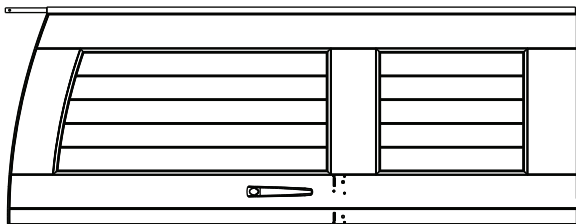

AGZ (x1)



TOOLS REQUIRED / OUTILS REQUIS / INSTRUMENTAL REQUERIDO

(Not included—unless otherwise indicated*) / (Non inclus — sauf indication contraire*) / (No incluido, salvo indicación contraria*)



7/16 in/po (≈11 mm)





PARTS IDENTIFIER / IDENTIFICATEUR DE PIÈCES / IDENTIFICADOR DE PIEZAS

CONTENTS OF BOX 1 / CONTENU DE LA BOÎTE 1 / CONTENIDO DE LA CAJA 1

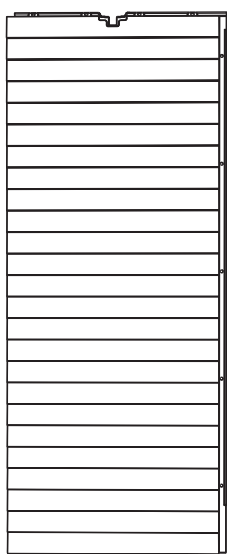

AHD (x4)

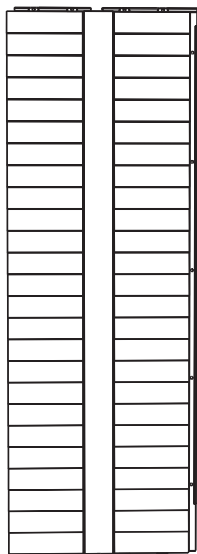

AGL (x4)

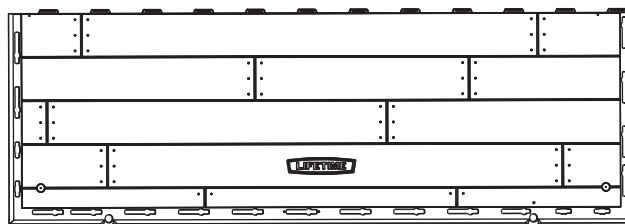

AGR (x2)

CONTENTS OF SMALL PARTS BOX / CONTENU DE LA BOÎTE DE PETITES PIÈCES / CONTENIDO DE LA CAJA DE PIEZAS PEQUEÑAS

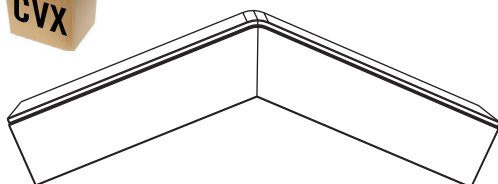

BYW (x2)

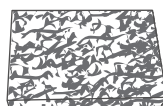

BYX (x4)



EUF (x1)

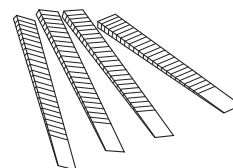

EUG (x4)

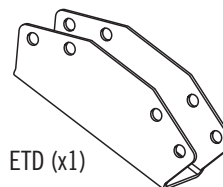

ETD (x1)

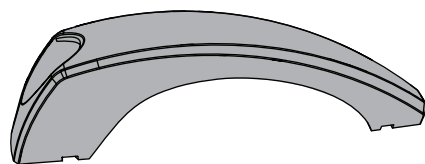

BYS (x2)



BYR (x2)

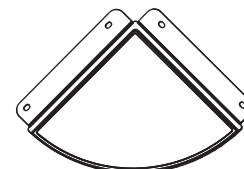

AFZ (x2)

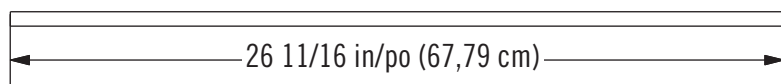

BYY (x4)



AIY (x2)

BLISTER PACKS / BLÎSTERS DE QUINCAILLERIE / BLISTERES DE HERRAJE



Remove this section for quick reference / Enlever cette section pour référence rapide / Retirar esta sección para referencia rápida



PARTS IDENTIFIER / IDENTIFICATEUR DE PIÈCES / IDENTIFICADOR DE PIEZAS

CONTENTS METAL KIT / CONTENU DU KIT DE PIÈCES EN MÉTAL / CONTENIDO DEL KIT DE PIEZAS DE METAL



Remove this section for quick reference / Enlever cette section pour référence rapide / Retirar esta sección para referencia rápida

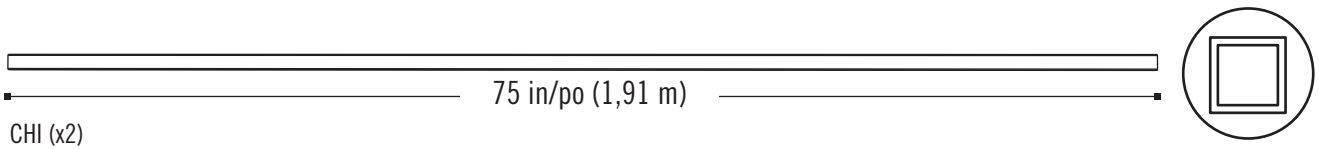
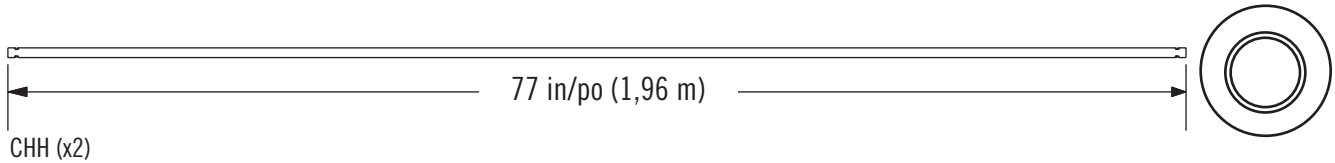
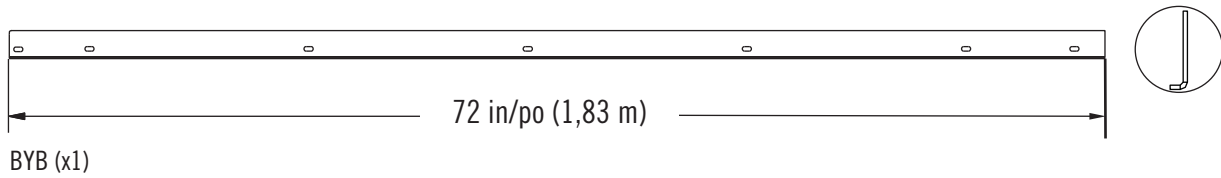
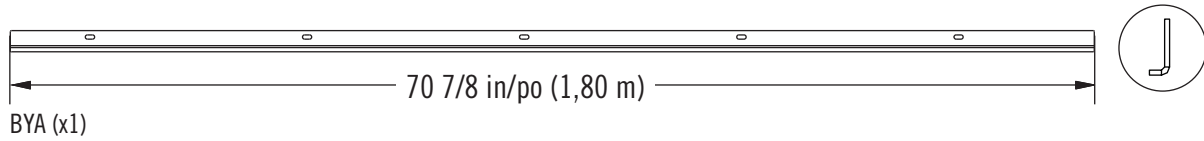
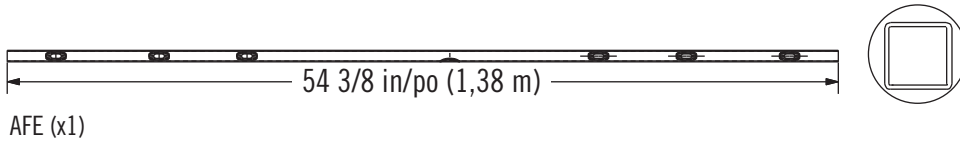
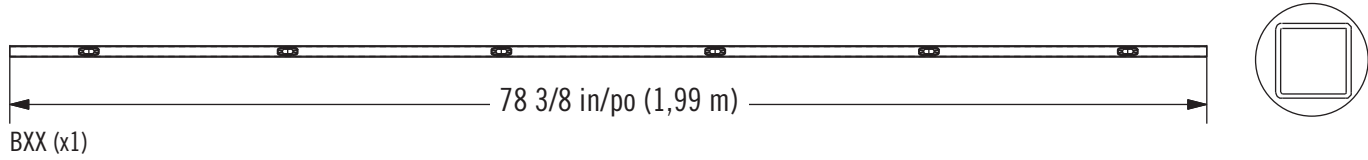
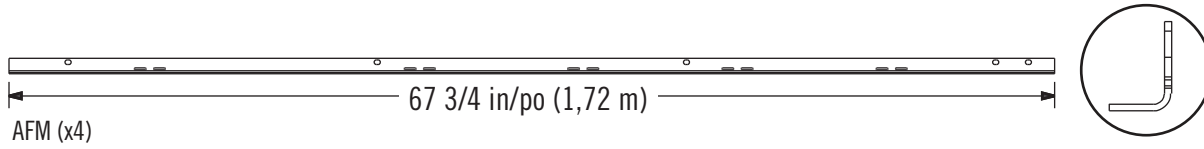
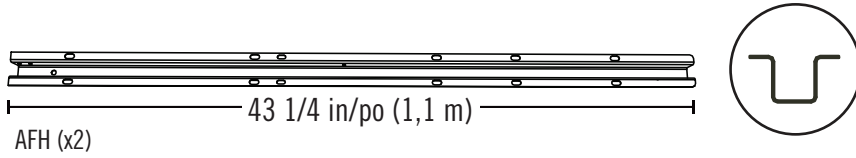
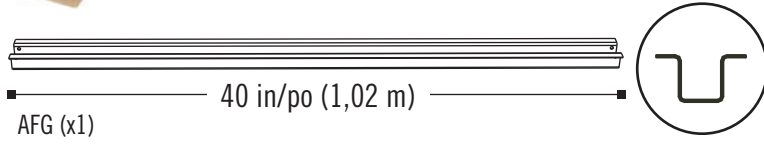



PARTS IDENTIFIER / IDENTIFICATEUR DE PIÈCES / IDENTIFICADOR DE PIEZAS

CONTENTS OF BOX 2 / CONTENU DE LA BOÎTE 2 / CONTENIDO DE LA CAJA 2

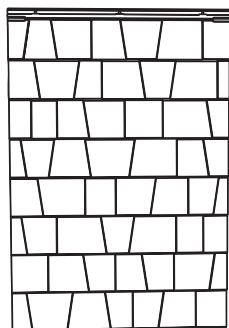

AGQ (x4)

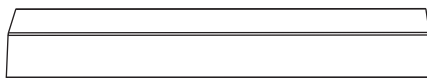

FYV (x1)



AFS (x1)

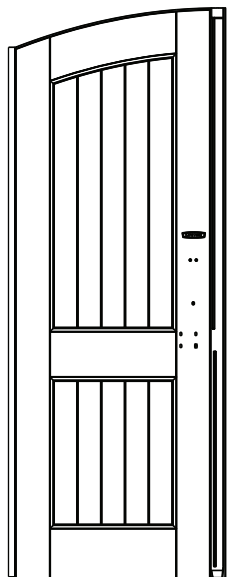

AGO (x1)

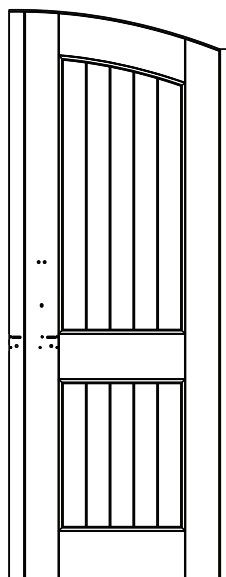

AGZ (x1)



AGF (x1)

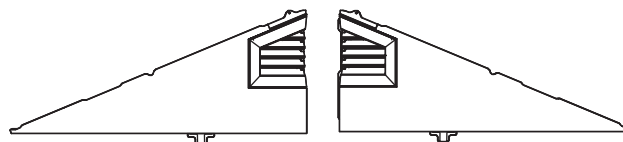

AGI (x1)

AGH (x1)

Remove this section for quick reference / Enlever cette section pour référence rapide / Retirar esta sección para referencia rápida



Remove this section for quick reference / Enlever cette section pour référence rapide / Retirar esta sección para referencia rápida

*THIS PAGE INTENTIONALLY LEFT BLANK
CETTE PAGE A ÉTÉ INTENTIONNELLEMENT LAISSÉE EN BLANC
ESTA PÁGINA SE HA DEJADO EN BLANCO INTENCIONADAMENTE*

► SECTION 9 (CONTINUED) / SECTION 9 (SUITE) / SECCIÓN 9 (CONTINUACIÓN)

TOOLS AND HARDWARE REQUIRED / OUTILS ET ACCESSOIRES REQUIS / INSTRUMENTAL Y HERRAJE REQUERIDOS

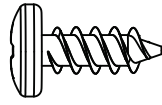

ADZ (x6)

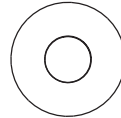

BXZ (x6)



- If you have trouble with this section, follow the code below to view a video on the assembly in this section.
- Si vous avez des problèmes avec cette section, suivez le code en bas pour voir un vidéo sur l'assemblage dans cette section.
- Si tiene problemas con esta sección, siga el código debajo para ver un video sobre el ensamble en esta sección.



<http://go.lifetime.com/7doorinstall>

9.1

- Place the **right door jamb (BYB)**, the wider of the two jambs, onto the edge of the right, front corner wall panel. The curved edge curves toward the inside of the shed. Align the holes in the jamb with those in the corner wall panel. Secure the jamb to the panel using six (6) **screws (ADZ)**. **The top hole does not yet require a screw.**
- Mettre le **montant droit (BYB)**, le plus large des deux montants, sur le bord du panneau angulaire droit avant. Le bord recourbé du montant courbe vers l'intérieur de l'abri. Aligner les trous dans le montant avec ceux du panneau angulaire. Attacher bien le montant au panneau à l'aide de six (6) **vis (ADZ)**. **Le trou supérieur n'exige pas encore d'une vis.**
- Colocar la **jamba derecha (BYB)**, la más ancha de las dos jambas, en el borde del panel angular derecho delantero. El borde curvado va hacia el interior de la caseta. Alinear los agujeros en la jamba con ellos en el panel angular. Sujetar la jamba al panel usando seis (6) **tornillos (ADZ)**. **El agujero superior no requiere un tornillo todavía.**

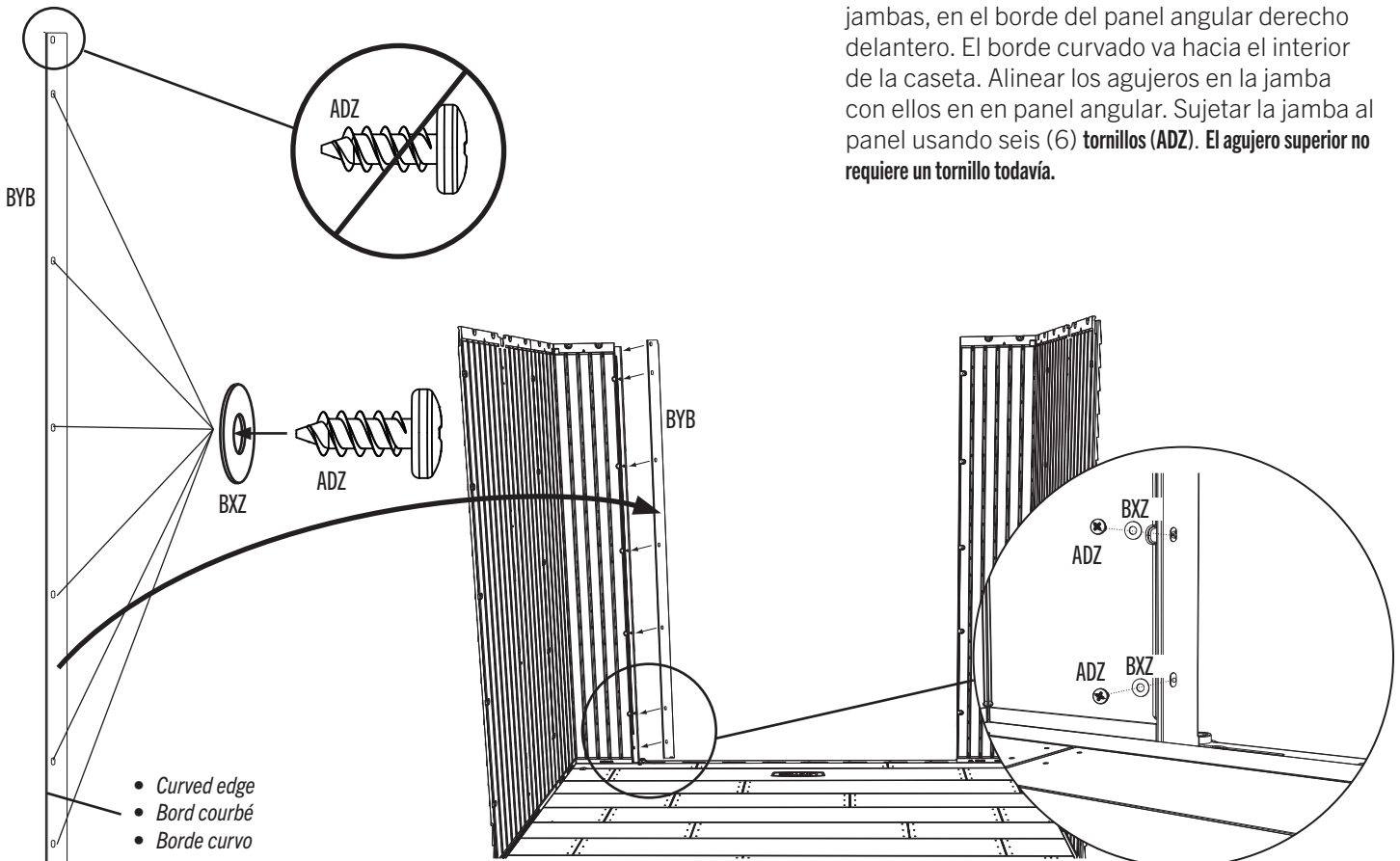

► SECTION 9 (CONTINUED) / SECTION 9 (SUITE) / SECCIÓN 9 (CONTINUACIÓN)

TOOLS AND HARDWARE REQUIRED / OUTILS ET ACCESSOIRES REQUIS / INSTRUMENTAL Y HERRAJE REQUERIDOS



7/16 in/po
(≈11 mm)

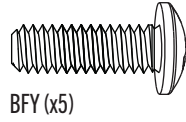

BFY (x5)

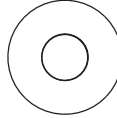

BXZ (x10)



ADJ (x5)

9.2

- Place the **left door jamb (BYA)** onto the edge of the left, front corner wall panel. The curved edge curves toward the outside of the shed. Align the holes in the jamb with those in the corner wall panel. Secure the jamb to the panel using the hardware included.
- Mettre le **montant gauche (BYA)** sur le bord du panneau angulaire gauche avant. Le bord recourbé du montant courbe vers l'extérieur de l'abri. Alignez les trous dans le montant avec ceux du panneau angulaire. Attacher bien le montant au panneau à l'aide de la quincaillerie incluse.
- Colocar la **jamba izquierda (BYA)** en el borde del panel angular izquierdo delantero. El borde curvado va hacia el exterior de la caseta. Alinear los agujeros en la jamba con ellos en panel angular. Sujetar la jamba al panel usando el herraje incluido.

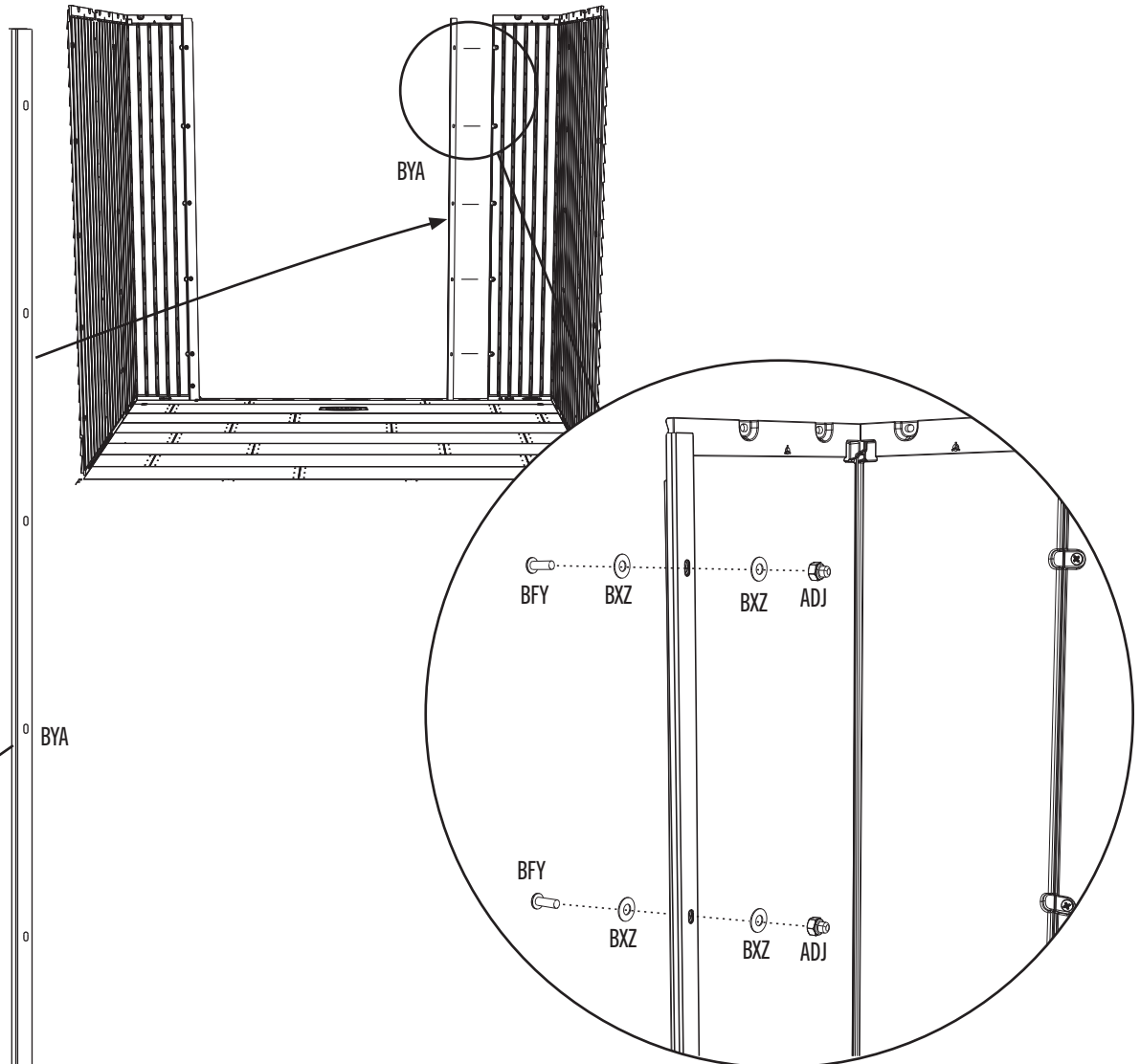

- Curved edge
- Bord courbé
- Borde curvo

► SECTION 9 (CONTINUED) / SECTION 9 (SUITE) / SECCIÓN 9 (CONTINUACIÓN)

TOOLS AND HARDWARE REQUIRED / OUTILS ET ACCESSOIRES REQUIS / INSTRUMENTAL Y HERRAJE REQUERIDOS



AHP (x2)

9.3



- Pull the hinge tube down out of the door about six inches. Align the hole at the bottom of the hinge tube with the slit in the bushing, and insert the tube. Insert a **cotter pin (AHP)** and bend the ends.
- Rallonger le tube d'articulation à peu près quinze centimètres du bord inférieur de la porte. Aligner le trou dans la partie inférieure du tube avec la fente dans la bague, et insérer le tube. Insérer une **clavette (AHP)**, et plier les extrémités.
- Extienda el tubo de articulación unos quince centímetros del borde inferior de la puerta. Alinear el agujero en la parte inferior del tubo con la rendija en el casquillo, e insertar el tubo. Insertar una **clavija (AHP)** y doble los extremos.

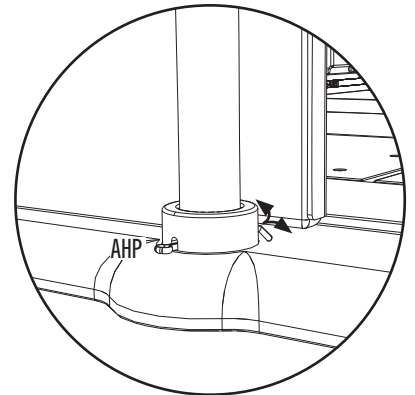
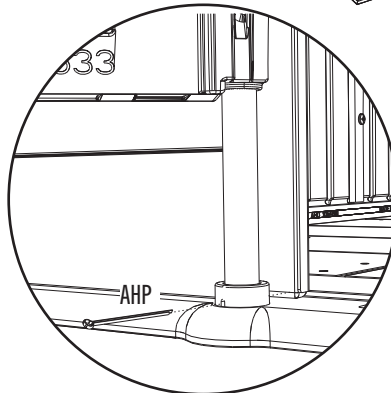
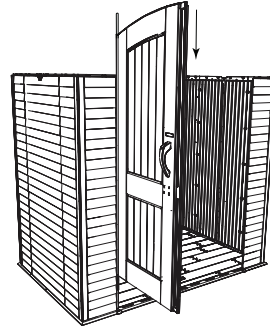
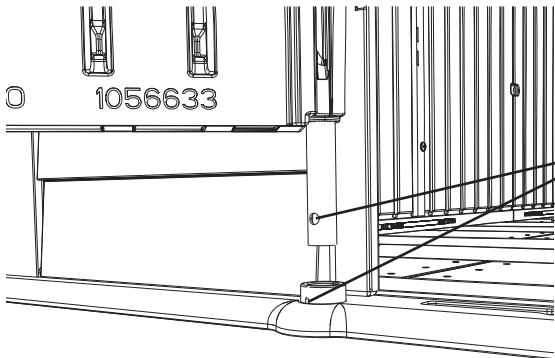

9.4



- Repeat the last step for the right door.
- Répéter l'étape précédente pour la porte droite.
- Repetir el paso anterior para la puerta derecha.

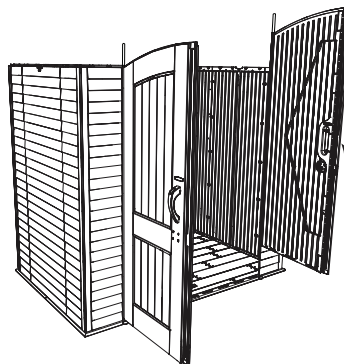

► SECTION 9 (CONTINUED) / SECTION 9 (SUITE) / SECCIÓN 9 (CONTINUACIÓN)

TOOLS AND HARDWARE REQUIRED / OUTILS ET ACCESSOIRES REQUIS / INSTRUMENTAL Y HERRAJE REQUERIDOS

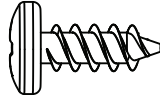

ADZ (x5)

9.5

- Slide the holes in the entry gable down over the two hinge tubes.
- Faire glisser les trous dans le pignon d'entrée sur les deux tubes.
- Deslizar los agujeros en la fachada de entrada sobre los dos tubos.

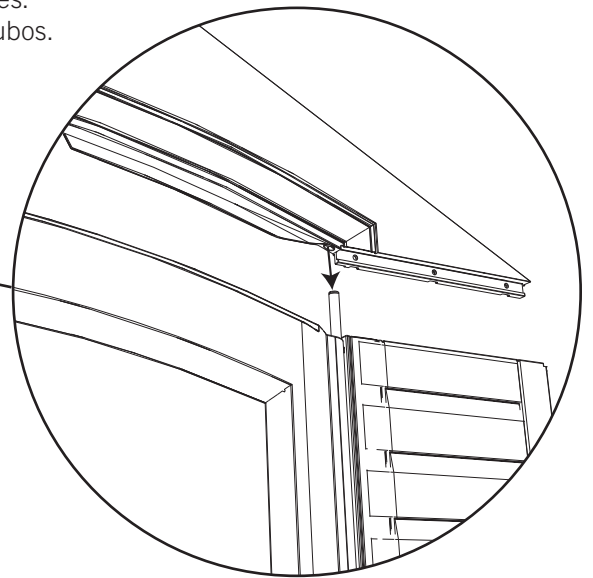
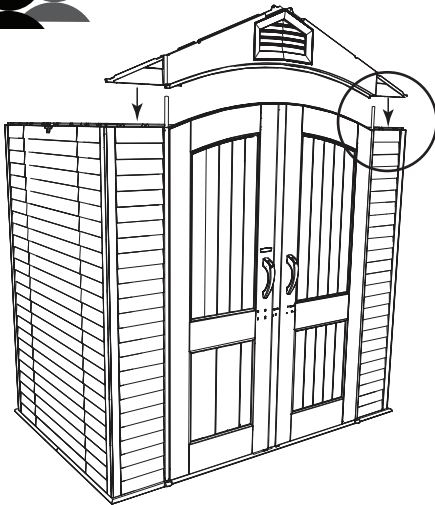

9.6

- Secure the entry gable to the shed using five (5) screws (ADZ).
- Sujeter la fachada de entrada a la caseta usando cinco (5) tornillos (ADZ).
- Attacher le pignon d'entrée à l'abri à l'aide de cinq (5) vis (ADZ).

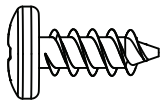

ADZ (x5)

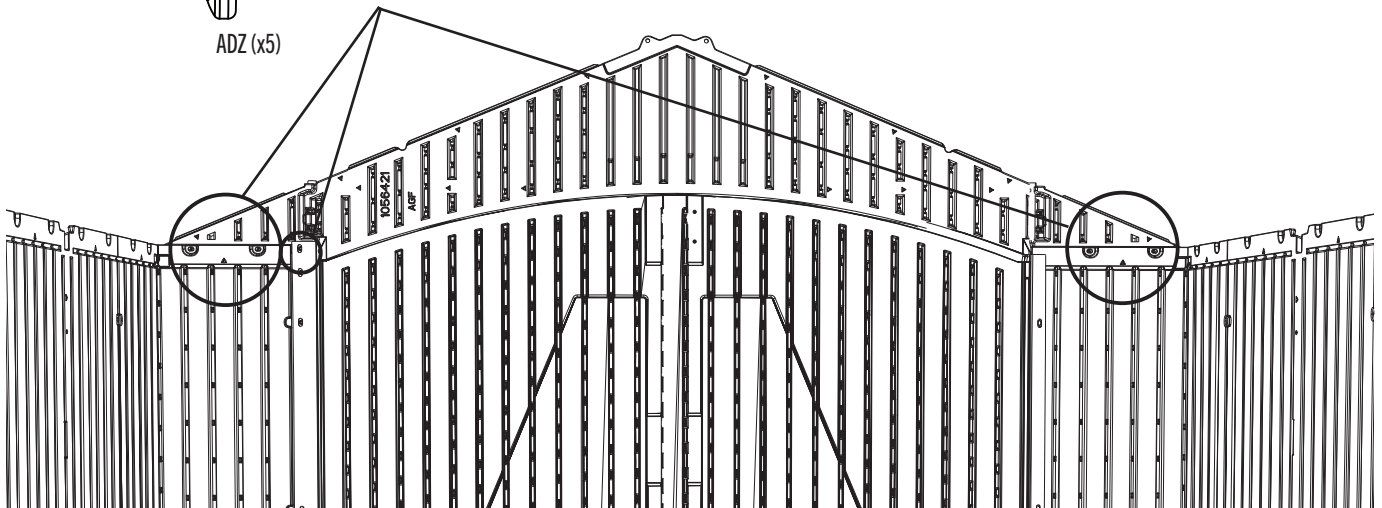

► SECTION 9 (CONTINUED) / SECTION 9 (SUITE) / SECCIÓN 9 (CONTINUACIÓN)

TOOLS AND HARDWARE REQUIRED / OUTILS ET ACCESSOIRES REQUIS / INSTRUMENTAL Y HERRAJE REQUERIDOS

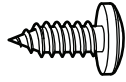

ADX (x2)



BYM (x1)

9.7

- Attach the **strike plate (BYM)** to the floor as shown.
- Attacher la **plaque de verrouillage (BYM)** au plancher comme illustré.
- Sujetar la **placa de cierre (BYM)** al piso como se muestra.

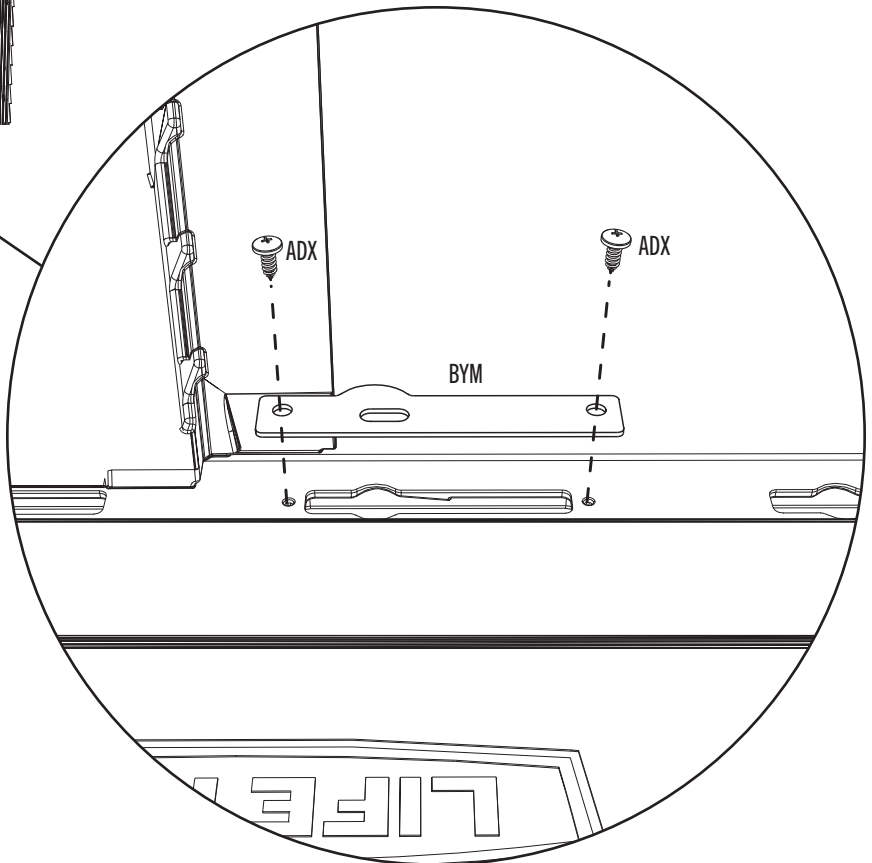
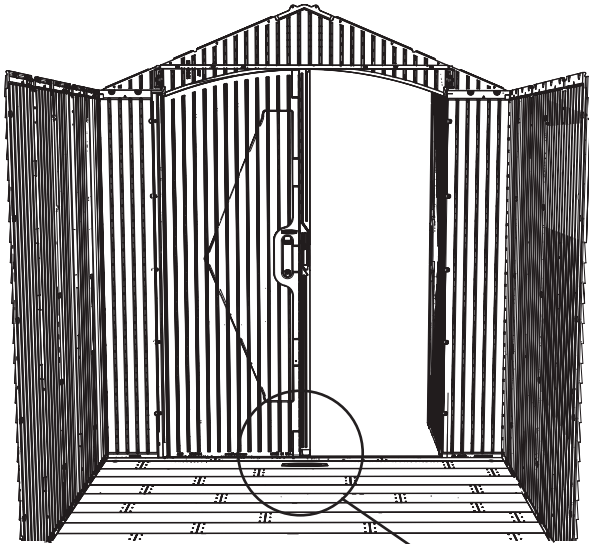



HARDWARE REQUIRED / QUINCAILLERIE REQUISE / HERRAJE REQUERIDO

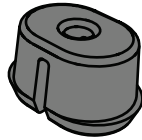

FEX (x16)

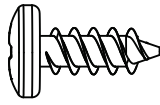

ADZ (x64)

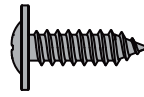

GJZ (x16)

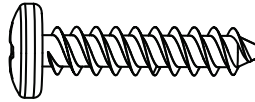

ADV (x16)

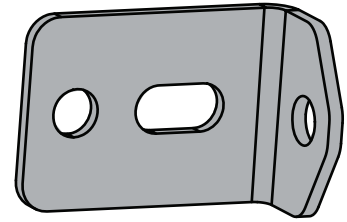

HLO (x16)



PARTS REQUIRED / PIÈCES REQUISES / PIEZAS REQUERIDAS

Metal parts / Pièces en plastique / Piezas de plástico

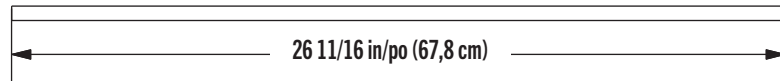

BYY (x4)

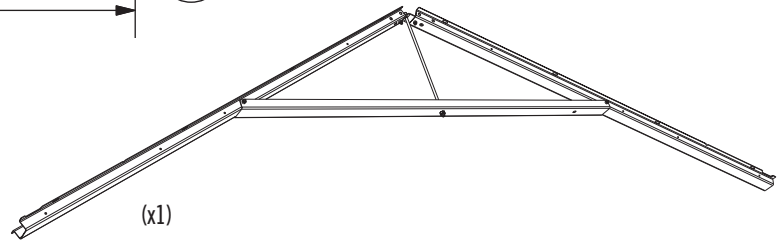

Plastic parts / Pièces en plastique / Piezas de plástico

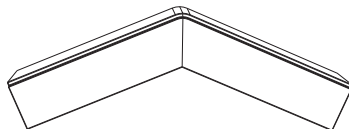

BYW (x2)

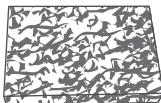

BYX (x4)

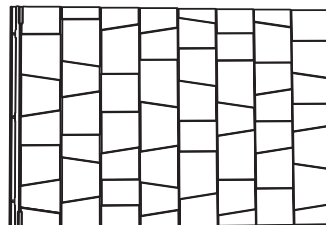

AGQ (x4)

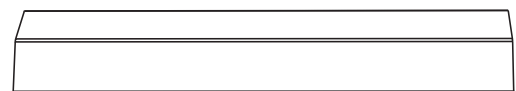

FYV (x1)

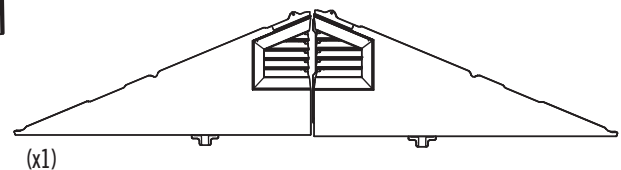

TOOLS REQUIRED / OUTILS REQUIS / INSTRUMENTAL REQUERIDO

(Not included—unless otherwise indicated*) / (Non inclus — sauf indication contraire*) / (No incluido, salvo indicación contraria*)



► SECTION 10 (CONTINUED) / SECTION 10 (SUITE) / SECCIÓN 10 (CONTINUACIÓN)

TOOLS AND HARDWARE REQUIRED / OUTILS ET QUINCAILLERIE REQUIS / INSTRUMENTAL Y HERRAJE REQUERIDOS



- If you have trouble with this section, follow the code below to view a video on the assembly in this section.
- Si vous avez des problèmes avec cette section, suivez le code en bas pour voir un vidéo sur l'assemblage dans cette section.
- Si tiene problemas con esta sección, siga el código debajo para ver un video sobre el ensamble en esta sección.

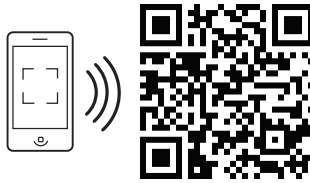

<http://go.lifetime.com/7x4roofinstall>

10.1

- Insert a **support tube (BYY)** into the notches of a **roof support panel (AGQ)**. Repeat this step for all roof panels.
- Insérer un **tube de support (BYY)** dans les encoches du **panneau de toit (AGQ)**. Répéter cette étape pour tous les panneaux de toit.
- Insertar un **tubo de soporte (BYY)** en la muescas del **panel de tejado (AGQ)**. Repetir este paso para todos los paneles de tejado.

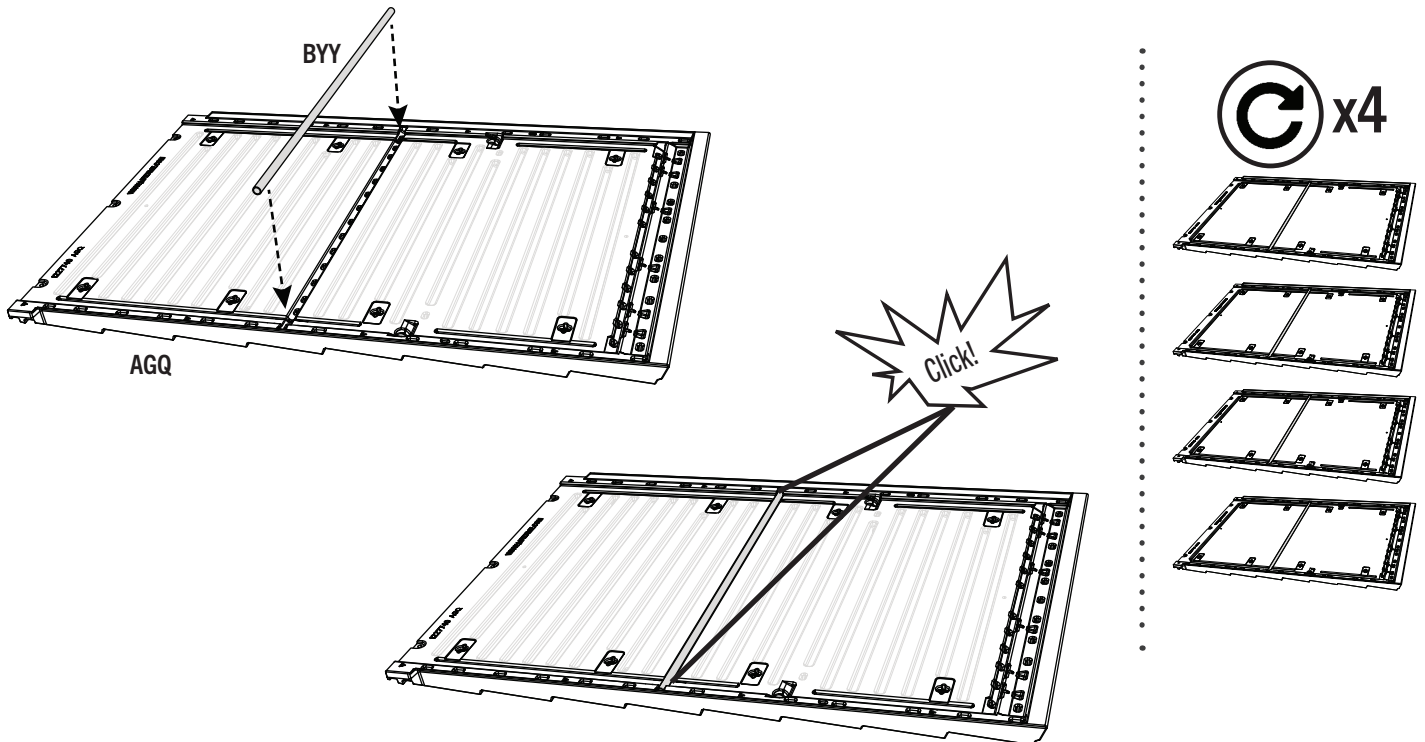

► SECTION 10 (CONTINUED) / SECTION 10 (SUITE) / SECCIÓN 10 (CONTINUACIÓN)

TOOLS AND HARDWARE REQUIRED / OUTILS ET QUINCAILLERIE REQUIS / INSTRUMENTAL Y HERRAJE REQUERIDOS

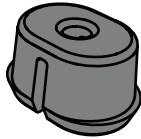

FEX (x4)

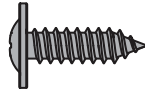

GJZ (x4)

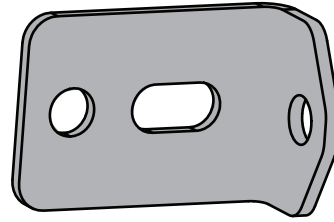

HLO (x4)

10.2

- Press four (4) **screw anchors (FEX)** into place on a roof panel, as shown. *Place the screw anchors on the side where the 3-letter ID is found.*
- Placez quatre (4) **ancrages à vis (FEX)** dans chaque panneau comme indiqué. *Placez les ancrages à vis sur le côté où se trouve l'identifiant à 3 lettres.*
- Presione para ubicar cuatro (4) **tornillos de anclaje (FEX)** en cada panel como se muestra. *Coloque los anclajes de tornillo en el lateral donde se encuentra el identificador de 3 letras.*

- 3-letter ID
- ID à 3 lettres
- ID de 3 letras

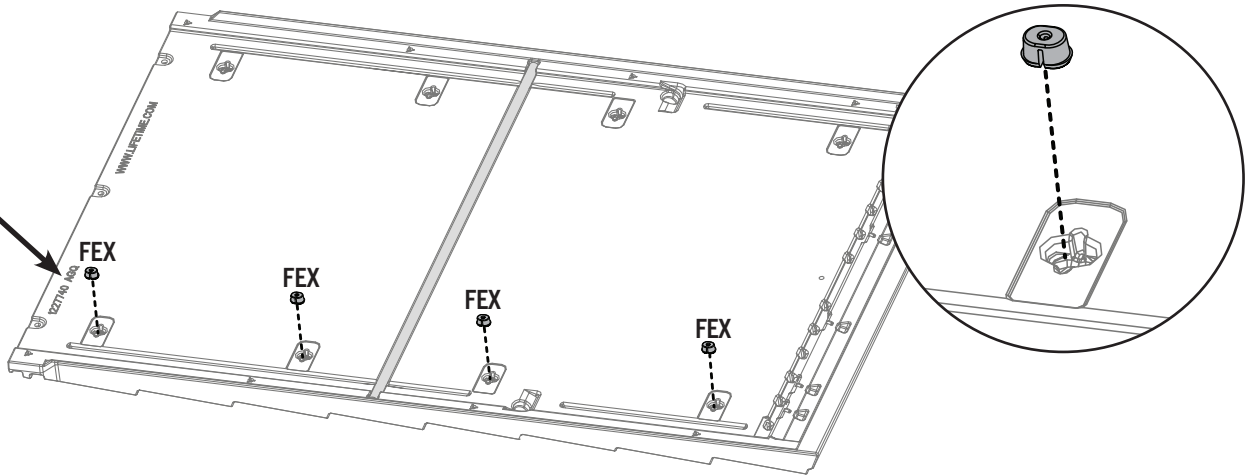

10.3

- Attach the **L-brackets (HLO)** with the hardware indicated.
- Fixez les **équerres en L (HLO)** à l'aide du matériel indiqué.
- Fije los **soportes en L (HLO)** con los herrajes indicados.

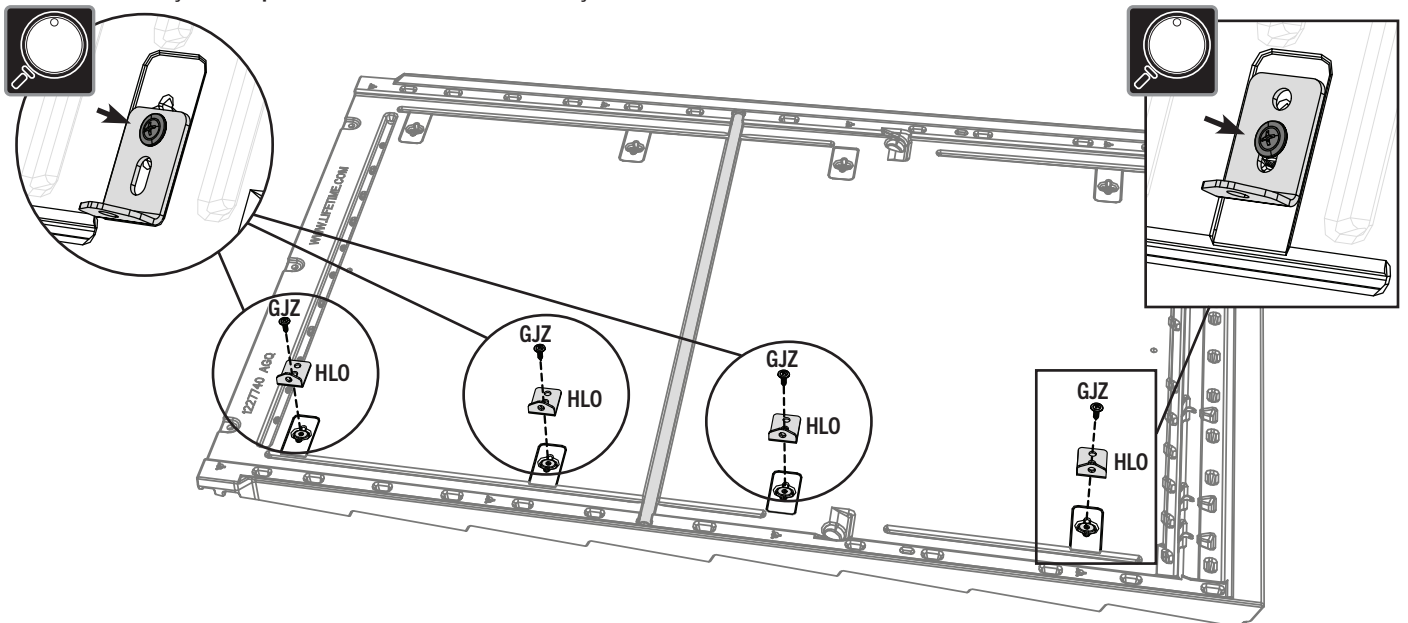

► SECTION 10 (CONTINUED) / SECTION 10 (SUITE) / SECCIÓN 10 (CONTINUACIÓN)

TOOLS AND HARDWARE REQUIRED / OUTILS ET QUINCAILLERIE REQUIS / INSTRUMENTAL Y HERRAJE REQUERIDOS



10.4



- Set a truss assembly into the notches on the first two opposite wall panels.
- Mettre une ferme dans les encoches des premiers deux panneaux muraux opposés.
- Colocar una cercha dentro de las muescas de los primeros dos paneles murales opuestos.

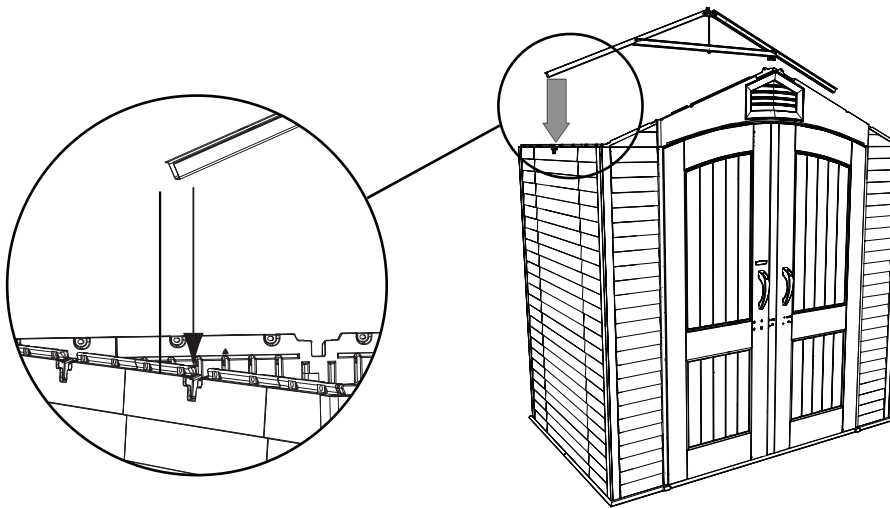

10.5



- Set the **roof panel (AGQ)** down onto the wall panel, gable, and truss. The L-brackets should face the gable. The groove along the bottom of the roof panel goes over the top of the wall panel.
- Posez le **panneau de toit (AGQ)** sur le panneau mural, le pignon et la ferme. Les équerres en L doivent être orientées vers le pignon. La rainure située au bas du panneau de toit passe au-dessus du panneau de mur.
- Coloque el **panel del techo (AGQ)** sobre el panel de la pared, el hastial y la viga. El soporte en L debe quedar orientado hacia el hastial. La ranura a lo largo de la parte inferior del panel del techo va por encima de la parte superior del panel de la pared.

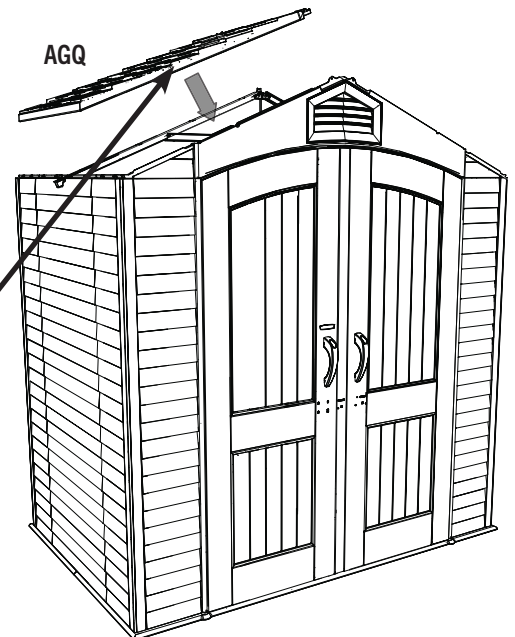

*The L-brackets are on this edge.
Les équerres en L sont sur ce bord.
Los soportes en L van en este borde.*

► SECTION 10 (CONTINUED) / SECTION 10 (SUITE) / SECCIÓN 10 (CONTINUACIÓN)

TOOLS AND HARDWARE REQUIRED / OUTILS ET QUINCAILLERIE REQUIS / INSTRUMENTAL Y HERRAJE REQUERIDOS



ADV (x4)

10.6

- Align the four holes in the wall panel with the slits at the bottom of the roof panel, and insert four (4) **screws (ADV)** to secure the panel in place.
- Aligner les quatre trous dans le panneau mural avec ceux au bord inférieur du panneau de toit, et insérer quatre (4) **vis (ADV)** pour l'attacher en place.
- Alinear los cuatro agujeros en el panel de pared con los al borde inferior del panel de tejado, e insertar cuatro (4) **tornillos (ADV)** para sujetarlo en su lugar.

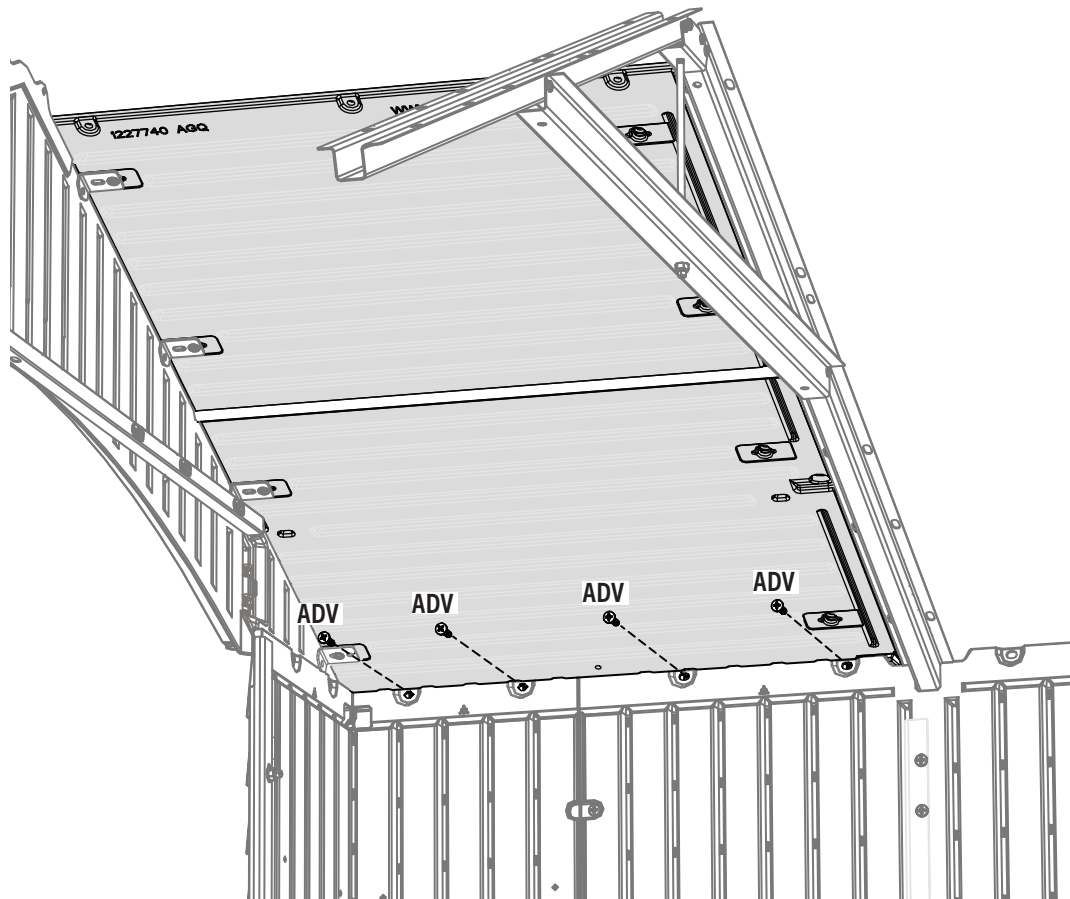

► SECTION 10 (CONTINUED) / SECTION 10 (SUITE) / SECCIÓN 10 (CONTINUACIÓN)

TOOLS AND HARDWARE REQUIRED / OUTILS ET QUINCAILLERIE REQUIS / INSTRUMENTAL Y HERRAJE REQUERIDOS

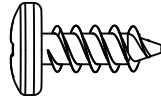

ADZ (x8)

10.7

- Align the L-brackets with the holes on the gable and insert four (4) screws (ADZ) to secure the gable to the roof panel.
- Alignez les équerres en L avec les trous situés du pignon et insérez quatre (4) vis (ADZ) pour fixer le pignon au panneau de toiture.
- Alinee los soportes en L con los orificios del hastial e inserte cuatro (4) tornillos (ADZ) para fijar el hastial al panel del techo.

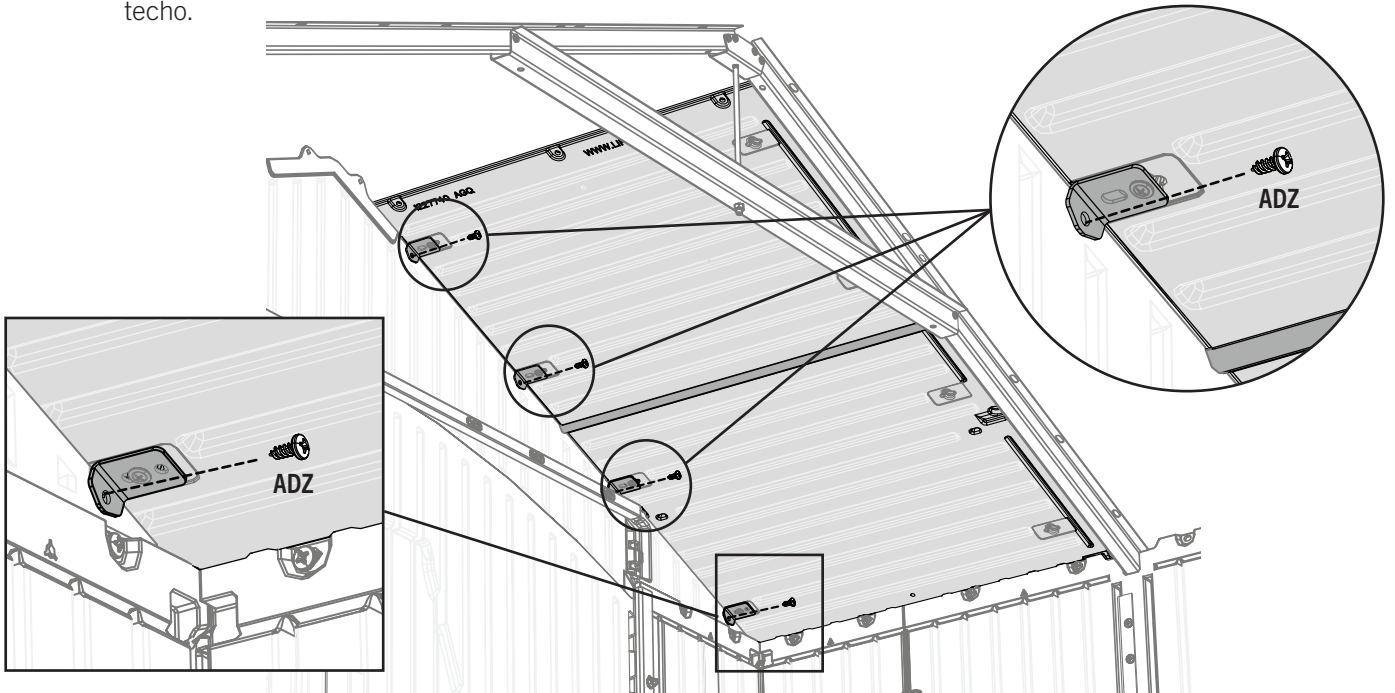

10.8

- Insert four (4) screws (ADZ) along the truss as shown.
- Insérez quatre (4) vis (ADZ) le long de la ferme comme indiqué.
- Inserte cuatro (4) tornillos (ADZ) a lo largo de la viga como se muestra.

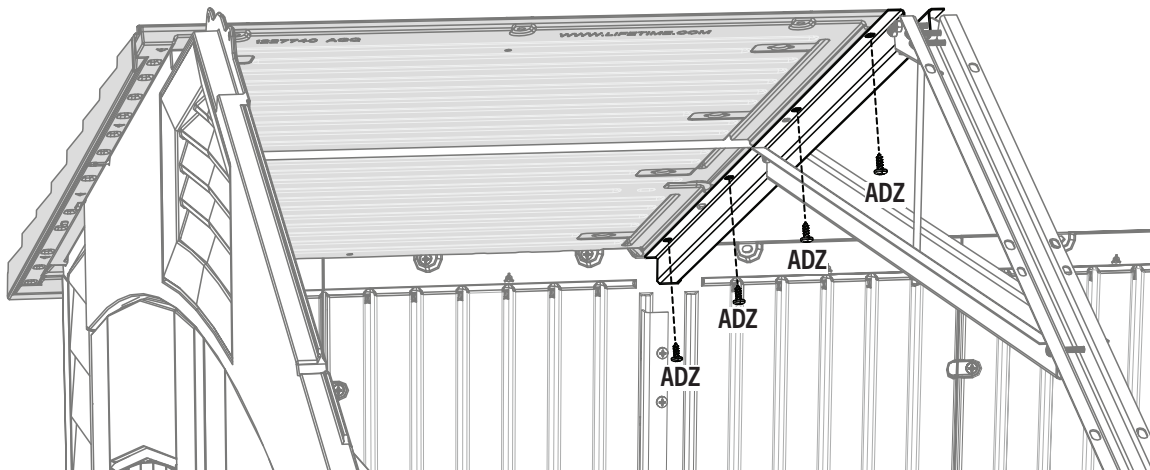

► SECTION 10 (CONTINUED) / SECTION 10 (SUITE) / SECCIÓN 10 (CONTINUACIÓN)

TOOLS AND HARDWARE REQUIRED / OUTILS ET QUINCAILLERIE REQUIS / INSTRUMENTAL Y HERRAJE REQUERIDOS

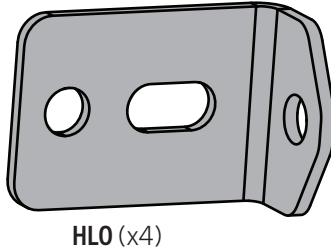
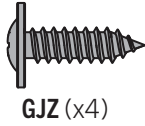

10.9

- Add the **screw anchors (FEX)**, the **L-bracket (HLO)** and the **screws (GJZ)** to the side of a second roof panel. *This hardware will be placed opposite of where the 3-letter ID is located.*
- Ajoutez les **ancrages à vis (FEX)**, l'**équerre en L (HLO)** et les **vis (GJZ)** sur un côté d'un deuxième panneau de toit. Ce matériel sera positionné sur le côté opposé à celui de l'identifiant à trois lettres.
- Añada los **anclajes de tornillo (FEX)**, el **soporte en L (HLO)** y los **tornillos (GJZ)** en un lado de un segundo panel de techo. Este herraje se colocará en el lado opuesto como identificador de tres letras.

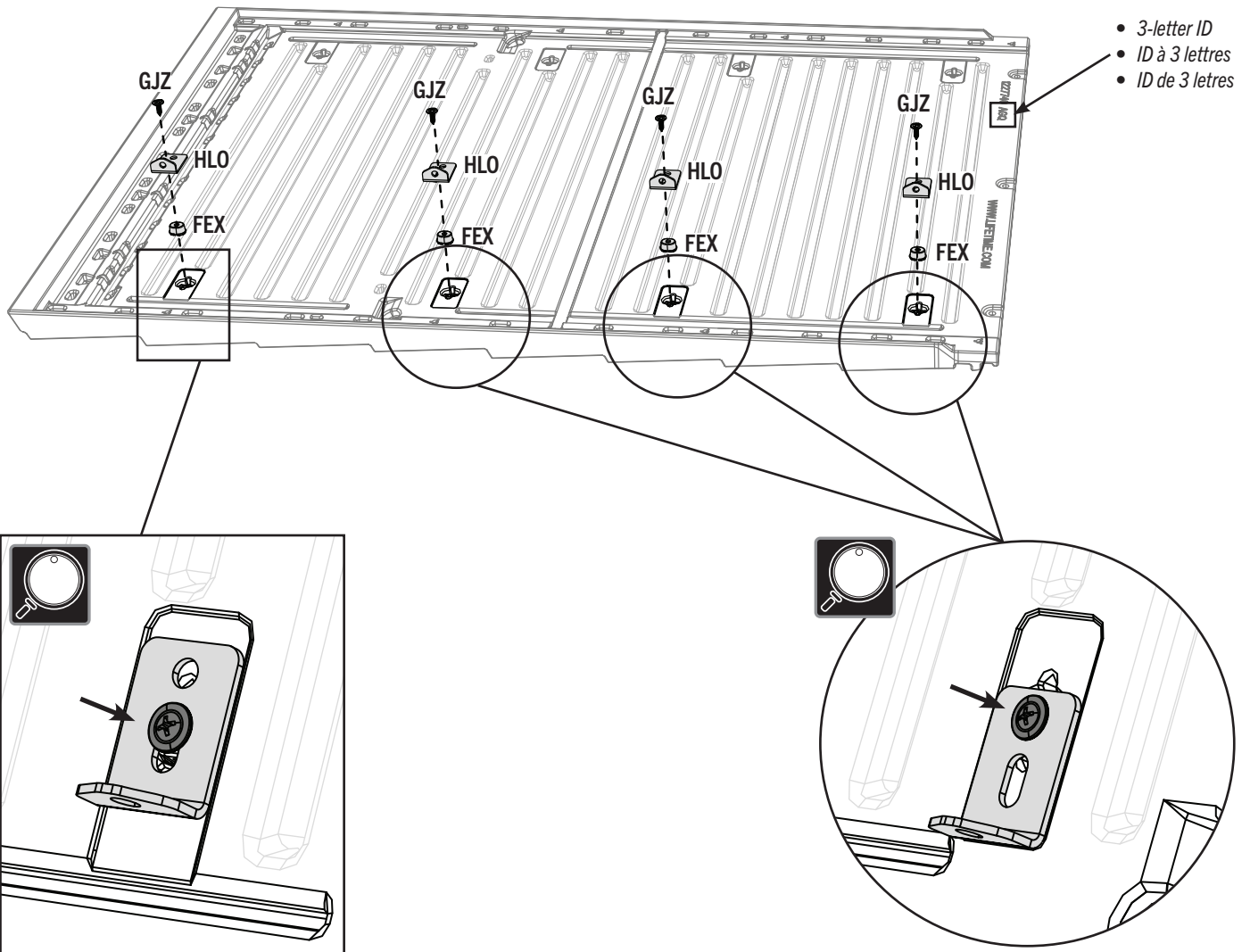

► SECTION 10 (CONTINUED) / SECTION 10 (SUITE) / SECCIÓN 10 (CONTINUACIÓN)

TOOLS AND HARDWARE REQUIRED / OUTILS ET QUINCAILLERIE REQUIS / INSTRUMENTAL Y HERRAJE REQUERIDOS

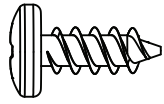

ADZ (x8)

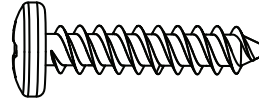

ADV (x4)

10.10

- Place the second roof panel.
- Placez le deuxième panneau de toit.
- Coloque el segundo panel del techo.

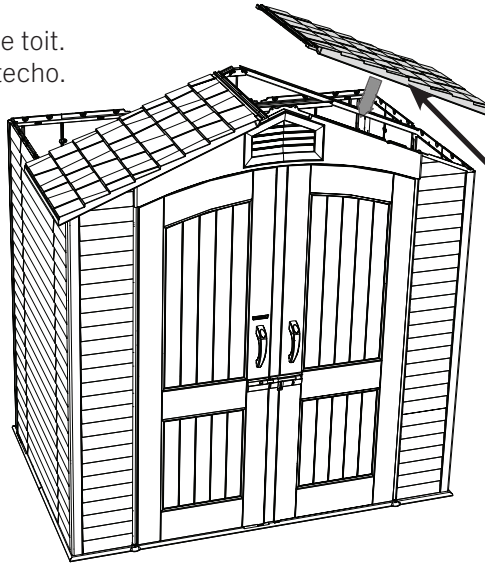

The L-brackets are on this edge.
Les équerres en L sont sur ce bord.
Los soportes en L van en este borde.

10.11

- Repeat steps 10.6–10.8 for the second roof panel.
- Répétez les étapes 10.6-10.8 pour le deuxième panneau de toit.
- Repita los pasos del 10.6 al 10.8 para el segundo panel del techo.

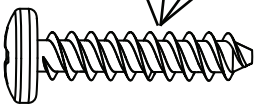
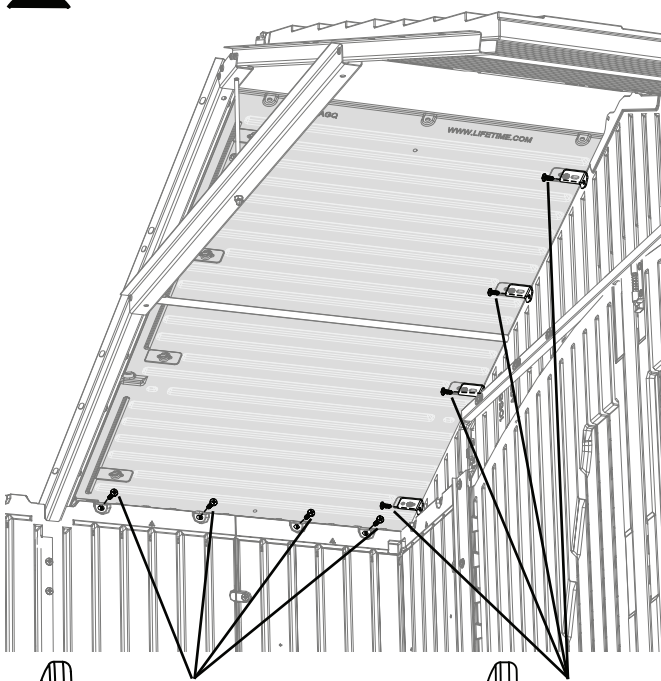

ADV

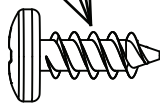

ADZ

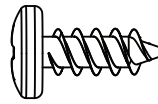
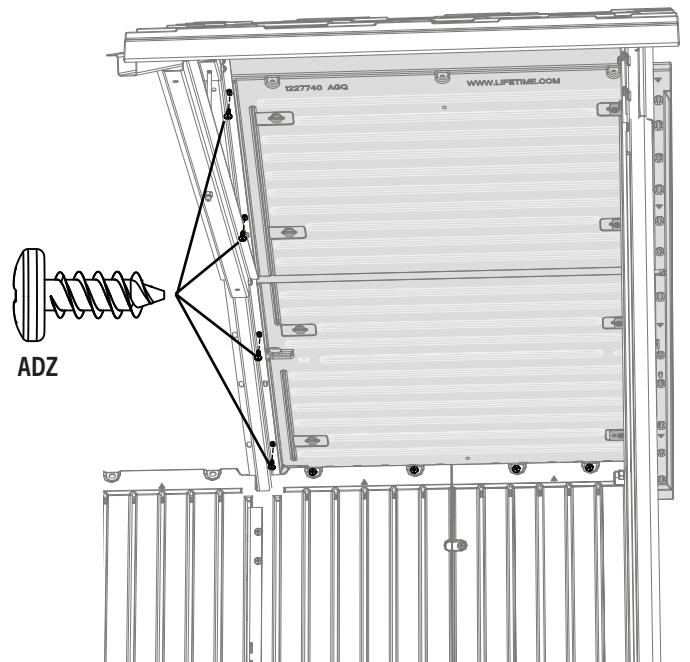

ADZ

► SECTION 10 (CONTINUED) / SECTION 10 (SUITE) / SECCIÓN 10 (CONTINUACIÓN)

TOOLS AND HARDWARE REQUIRED / OUTILS ET QUINCAILLERIE REQUIS / INSTRUMENTAL Y HERRAJE REQUERIDOS

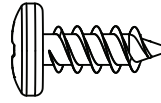

ADZ (x12)

10.12

- Set the rear gable onto the back wall panels, and secure it with twelve (12) screws (ADZ).
- Mettre le pignon arrière aux panneaux muraux arrière, et attacher-le à l'aide de douze (12) vis (ADZ).
- Colocar la fachada trasera en los paneles murales traseros, y sujetarla usando doce (12) tornillos (ADZ).

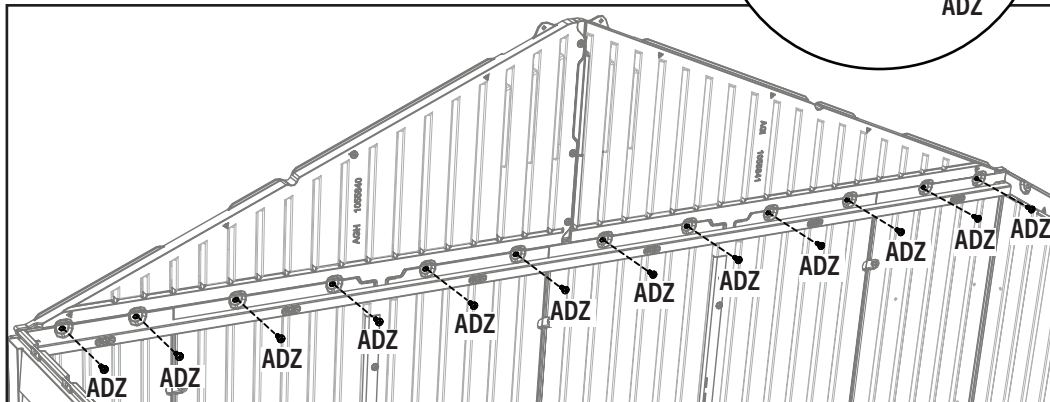
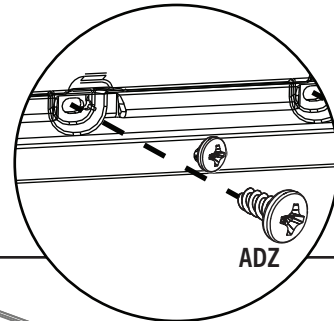
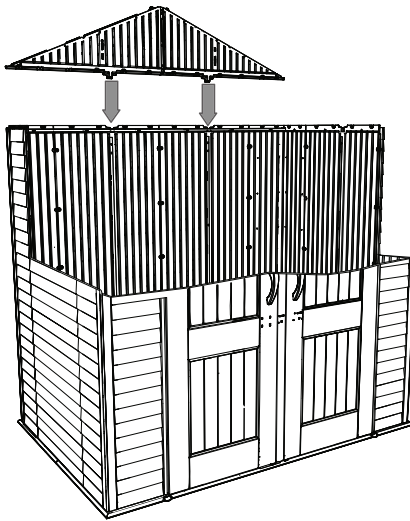

► SECTION 10 (CONTINUED) / SECTION 10 (SUITE) / SECCIÓN 10 (CONTINUACIÓN)

TOOLS AND HARDWARE REQUIRED / OUTILS ET QUINCAILLERIE REQUIS / INSTRUMENTAL Y HERRAJE REQUERIDOS

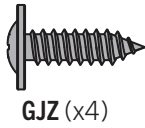

GJZ (x4)

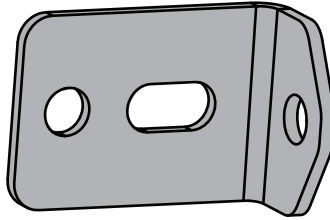

HLO (x4)

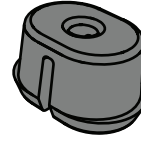

FEX (x4)

10.13

- Add the **screw anchors (FEX)**, the **L-bracket (HLO)** and the **screws (GJZ)** to the side of the third roof panel. *This hardware will be placed opposite of where the 3-letter ID is located.*
- Ajoutez les **ancrages à vis (FEX)**, l'**équerre en L (HLO)** et les **vis (GJZ)** sur le côté opposé de celui de l'identifiant à trois lettres.
- Añada los **anclajes de tornillo (FEX)**, el **soporte en L (HLO)** y los **tornillos (GJZ)** en el lado de del tercer panel de techo. Este herraje se colocará en el lado opuesto como identificador de tres letras.

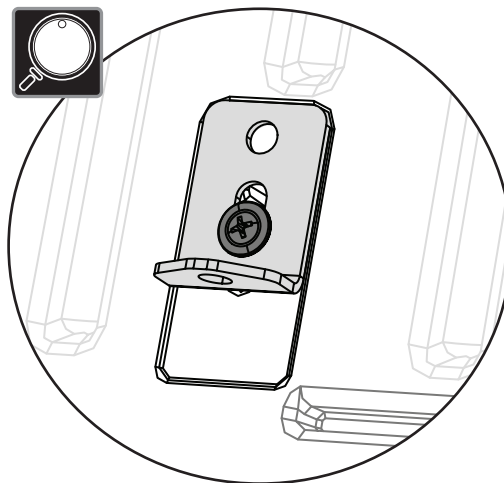
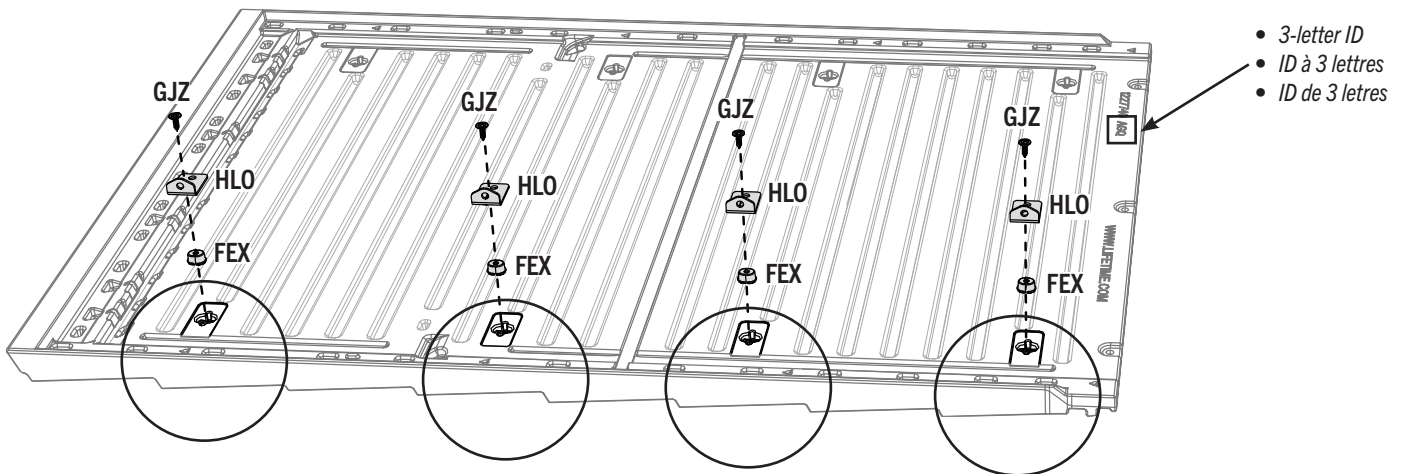

► SECTION 10 (CONTINUED) / SECTION 10 (SUITE) / SECCIÓN 10 (CONTINUACIÓN)

TOOLS AND HARDWARE REQUIRED / OUTILS ET QUINCAILLERIE REQUIS / INSTRUMENTAL Y HERRAJE REQUERIDOS

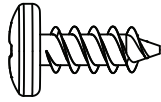

ADZ (x8)

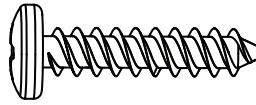

ADV (x4)

10.14

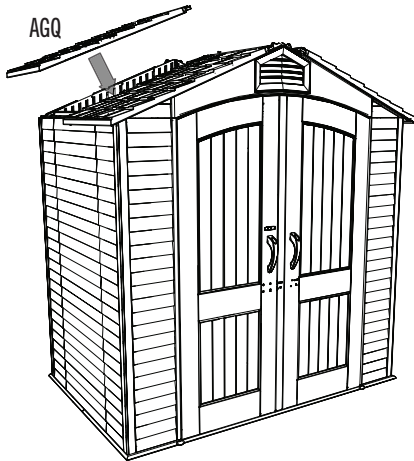

- Set the third **roof panel (AGQ)** down onto the wall panel, gable, and truss. Align the L-brackets with the holes on the gable.
- Posez le troisième **panneau de toit (AGQ)** sur le panneau mural, le pignon et la ferme. Alignez les équerres en L avec les trous situés du pignon.
- Coloque el tercer **panel del techo (AGQ)** sobre el panel de la pared, el hastial y la viga. Alinee los soportes en L con los orificios del hastial.

10.15



- Repeat steps 10.6–10.8 for the third roof panel.
- Répétez les étapes 10.6-10.8 pour le troisième panneau de toit.
- Repita los pasos del 10.6 al 10.8 para el tercer panel del techo.

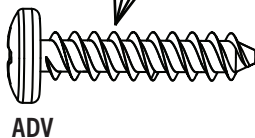
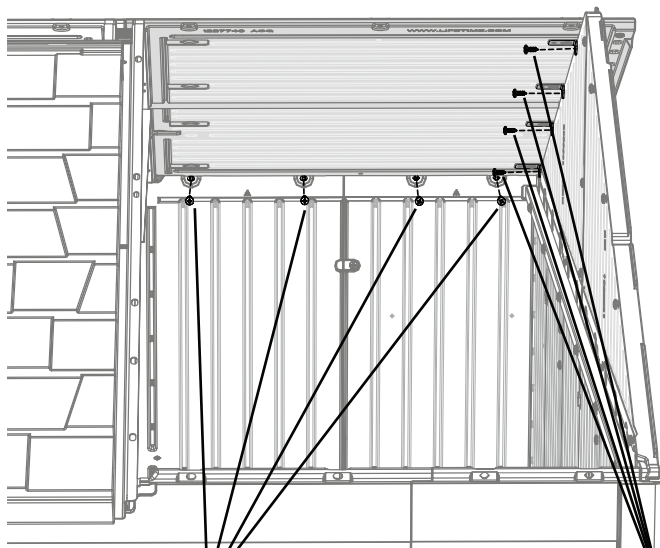

ADV

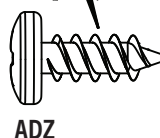

ADZ

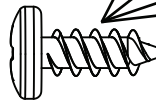
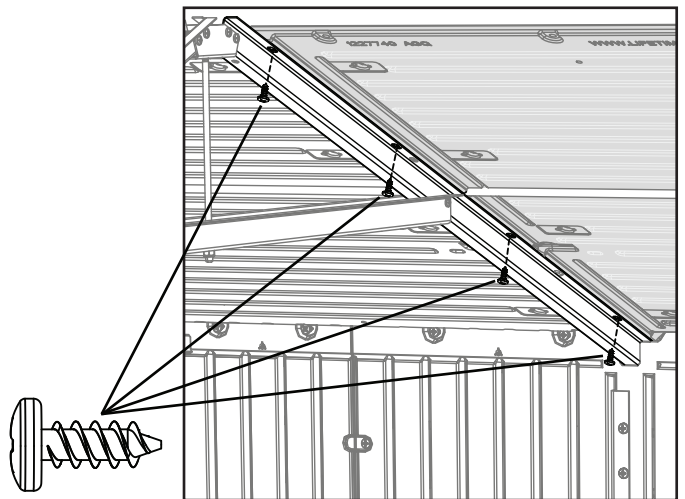

ADZ

► SECTION 10 (CONTINUED) / SECTION 10 (SUITE) / SECCIÓN 10 (CONTINUACIÓN)

TOOLS AND HARDWARE REQUIRED / OUTILS ET QUINCAILLERIE REQUIS / INSTRUMENTAL Y HERRAJE REQUERIDOS

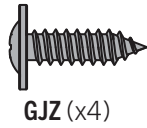

GJZ (x4)

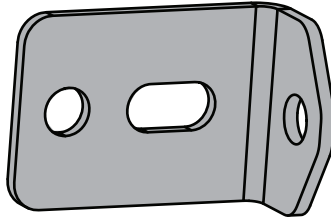

HLO (x4)

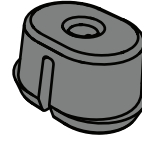

FEX (x4)

10.16

- Add the screw anchors (FEX), the L-bracket (HLO) and the screws (GJZ) to the side of the fourth roof panel. *Place the hardware on the side where the 3-letter ID is found.*
- Ajoutez les ancrages à vis (FEX), l'équerre en L (HLO) et les vis (GJZ) sur le côté du quatrième panneau de toit. *Placez le quincaillerie sur le côté où se trouve l'identifiant à 3 lettres.*
- Añada los anclajes de tornillo (FEX), el soporte en L (HLO) y los tornillos (GJZ) en el lado de del cuarto panel de techo. *Coloque el herraje en el lateral donde se encuentra el identificador de 3 letras.*

- 3-letter ID
- ID à 3 lettres
- ID de 3 letras

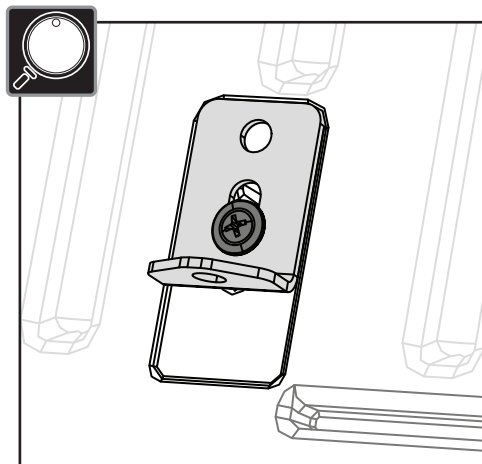
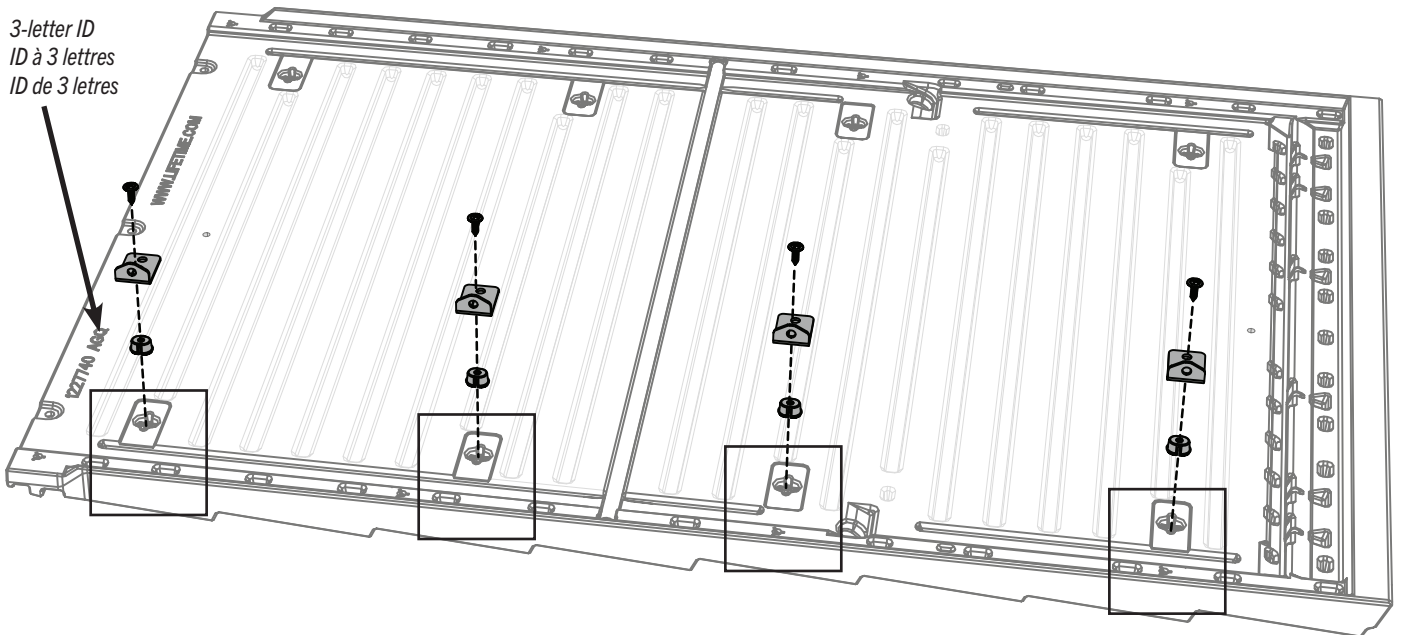

► SECTION 10 (CONTINUED) / SECTION 10 (SUITE) / SECCIÓN 10 (CONTINUACIÓN)

TOOLS AND HARDWARE REQUIRED / OUTILS ET QUINCAILLERIE REQUIS / INSTRUMENTAL Y HERRAJE REQUERIDOS

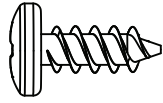

ADZ (x8)

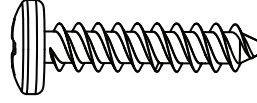

ADV (x4)

10.17

- Set the fourth **roof panel (AGQ)** down onto the wall panel, gable, and truss. Align the L-brackets with the holes on the gable.
- Posez le quatrième **panneau de toit (AGQ)** sur le panneau mural, le pignon et la ferme. Alignez les équerres en L avec les trous situés du pignon.
- Coloque el cuarto **panel del techo (AGQ)** sobre el panel de la pared, el hastial y la viga. Alinee los soportes en L con los orificios del hastial.



10.18

- Repeat steps 10.6–10.8 for the fourth roof panel.
- Répétez les étapes 10.6-10.8 pour le quatrième panneau de toit.
- Repita los pasos del 10.6 al 10.8 para el cuarto panel del techo.

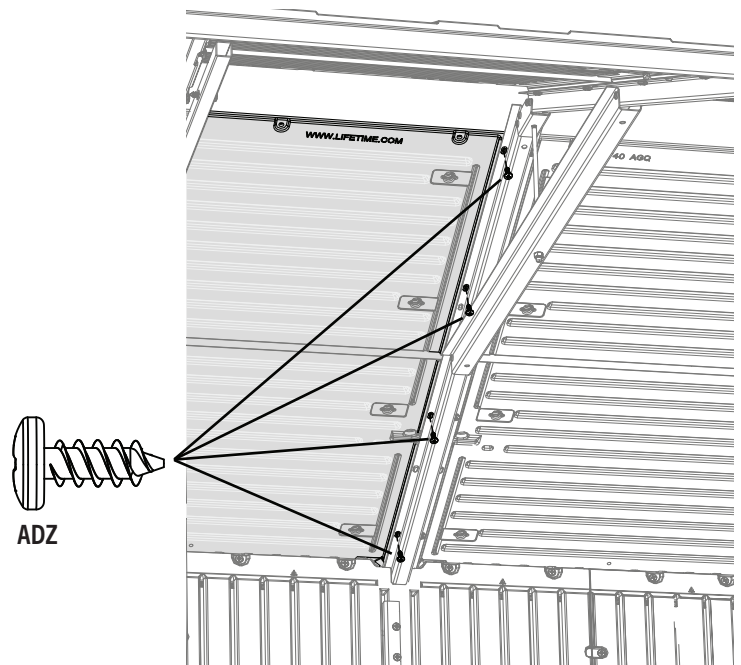
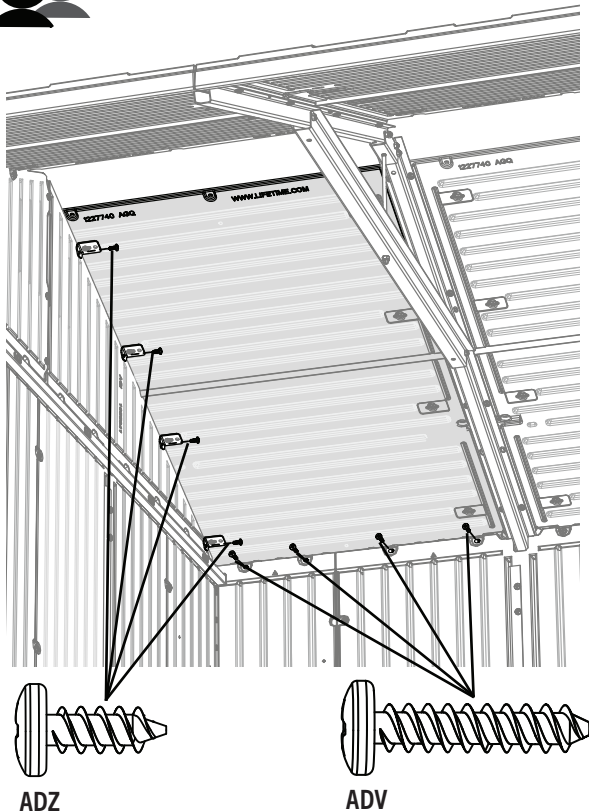

► SECTION 10 (CONTINUED) / SECTION 10 (SUITE) / SECCIÓN 10 (CONTINUACIÓN)

TOOLS AND HARDWARE REQUIRED / OUTILS ET QUINCAILLERIE REQUIS / INSTRUMENTAL Y HERRAJE REQUERIDOS

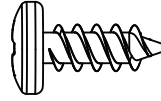

ADZ (x2)

10.19

- Insert two (2) pieces of **foam (BYX)** into each **end cap (BYW)** as shown. **There are two end caps.**
- Insérer deux (2) pièces de **mousse (BYX)** dans chaque **capuchon (BYW)** comme illustré. **Il y a deux capuchons.**
- Insertar dos (2) piezas de **espuma (BYX)** en cada **tapón (BYW)** como se muestra. **Hay dos tapones.**

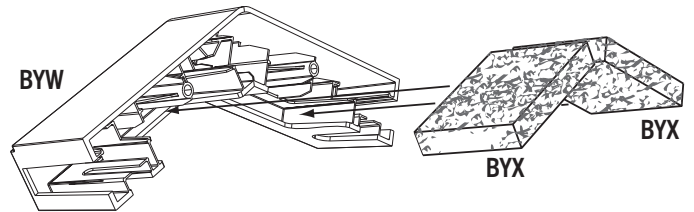
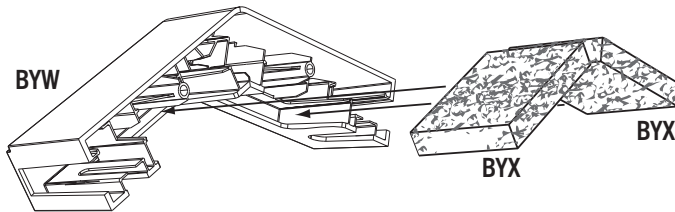

10.20

- Connect the end cap to the outside of the shed using two (2) **screws (ADZ)**.
- Attacher le capuchon à l'extérieur de l'abri à l'aide de deux (2) **vis (ADZ)**.
- Sujetar el tapón al exterior de la caseta usando dos (2) **tornillos (ADZ)**.

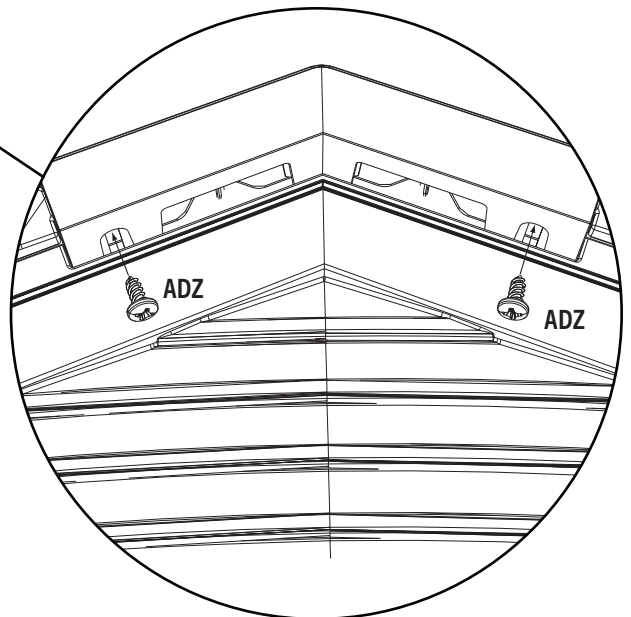
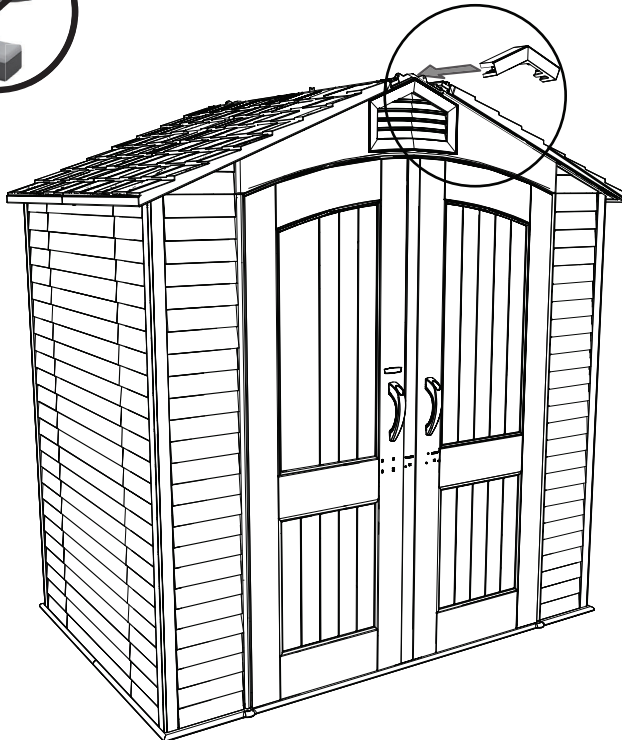

► SECTION 10 (CONTINUED) / SECTION 10 (SUITE) / SECCIÓN 10 (CONTINUACIÓN)

TOOLS AND HARDWARE REQUIRED / OUTILS ET QUINCAILLERIE REQUIS / INSTRUMENTAL Y HERRAJE REQUERIDOS

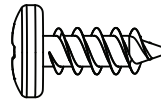

ADZ (x2)

10.21

- Connect the end cap to the inside of the shed using two (2) screws (ADZ).
- Attacher le capuchon à l'intérieur de l'abri à l'aide de deux (2) vis (ADZ).
- Sujetar el tapón al interior de la caseta usando dos (2) tornillos (ADZ).

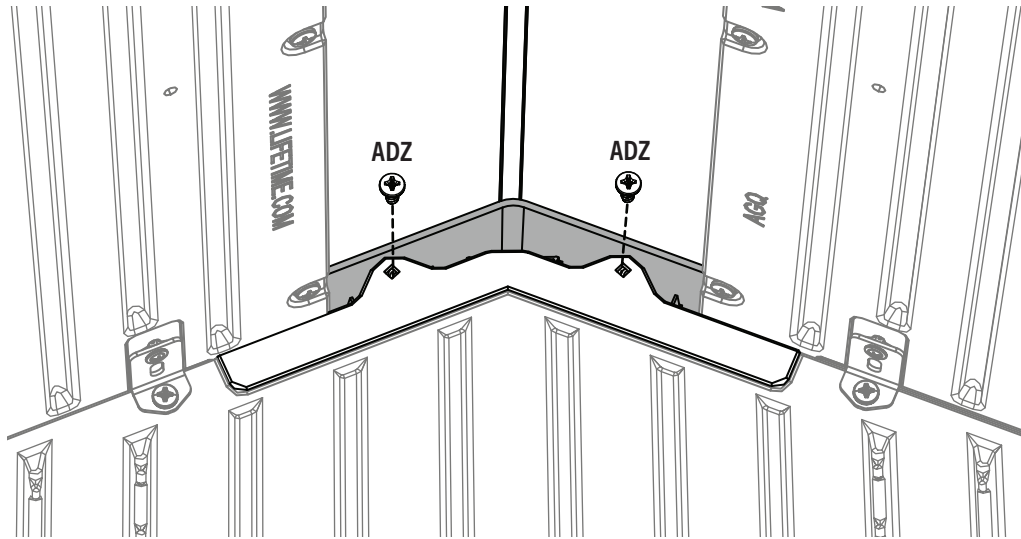

10.22

- Slide the skylight (FYV) onto the top of the shed and underneath the end cap. The end of the skylight should touch the inside wall of the end cap.
- Faire glisser la lucarne (FYV) sur le toit et en dessous du capuchon. L'extrémité de la lucarne doit toucher le paroi intern du capuchon.
- Deslizar el tragaluz (FYV) en el tejado y debajo el tapón. El extremo del tragaluz debe tocar la pared interna del tapón.

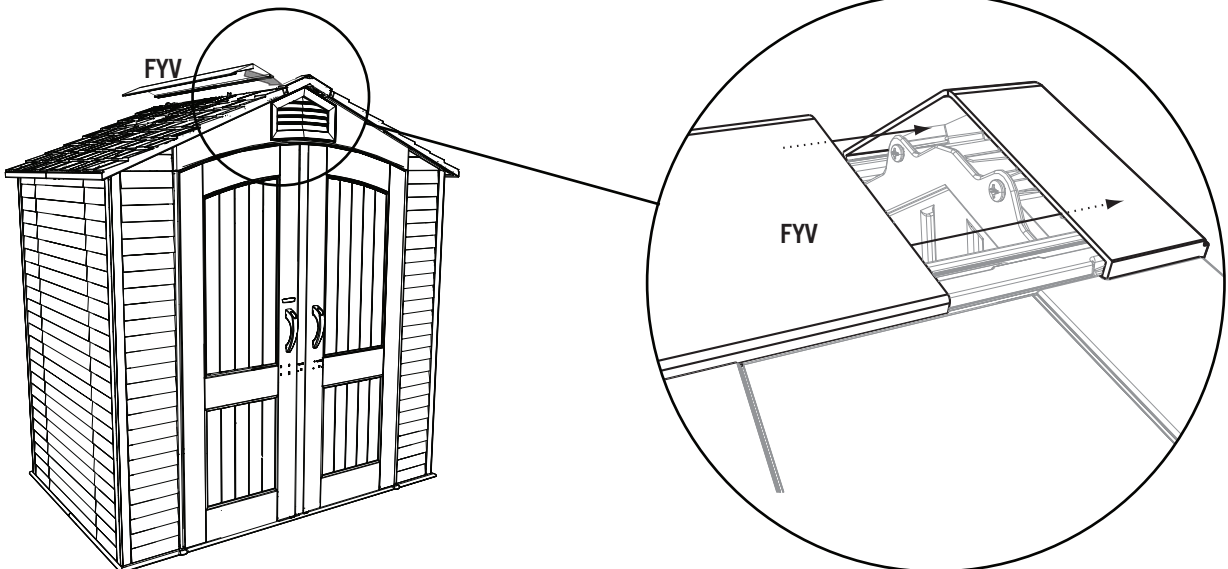

► SECTION 10 (CONTINUED) / SECTION 10 (SUITE) / SECCIÓN 10 (CONTINUACIÓN)

TOOLS AND HARDWARE REQUIRED / OUTILS ET QUINCAILLERIE REQUIS / INSTRUMENTAL Y HERRAJE REQUERIDOS

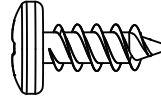

ADZ (x12)

10.23



- Connect the skylight (FYV) to the roof panels using twelve (12) screws (ADZ).
- Attacher la lucarne (FYV) à l'intérieur de l'abri à l'aide de douze (12) vis (ADZ).
- Sujetar el tragaluz (FYV) de la caseta usando doce (12) tornillos (ADZ).

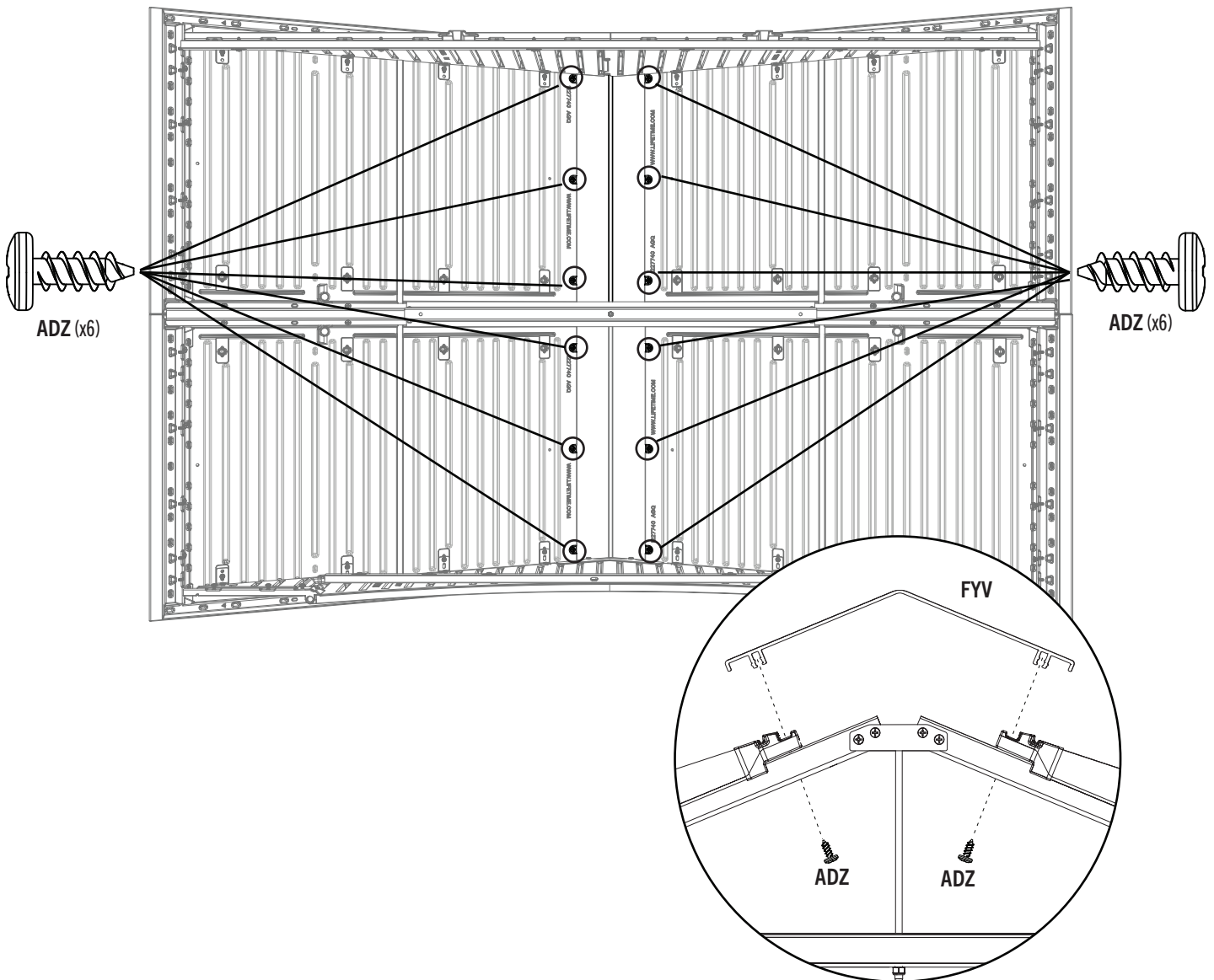

► SECTION 10 (CONTINUED) / SECTION 10 (SUITE) / SECCIÓN 10 (CONTINUACIÓN)

TOOLS AND HARDWARE REQUIRED / OUTILS ET QUINCAILLERIE REQUIS / INSTRUMENTAL Y HERRAJE REQUERIDOS

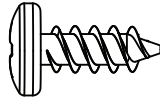

ADZ (x4)

10.24

- Connect the end cap to the outside of the shed using two (2) screws (ADZ).
- Attacher le capuchon à l'extérieur de l'abri à l'aide de deux (2) vis (ADZ).
- Sujetar el tapón al exterior de la caseta usando dos (2) tornillos (ADZ).

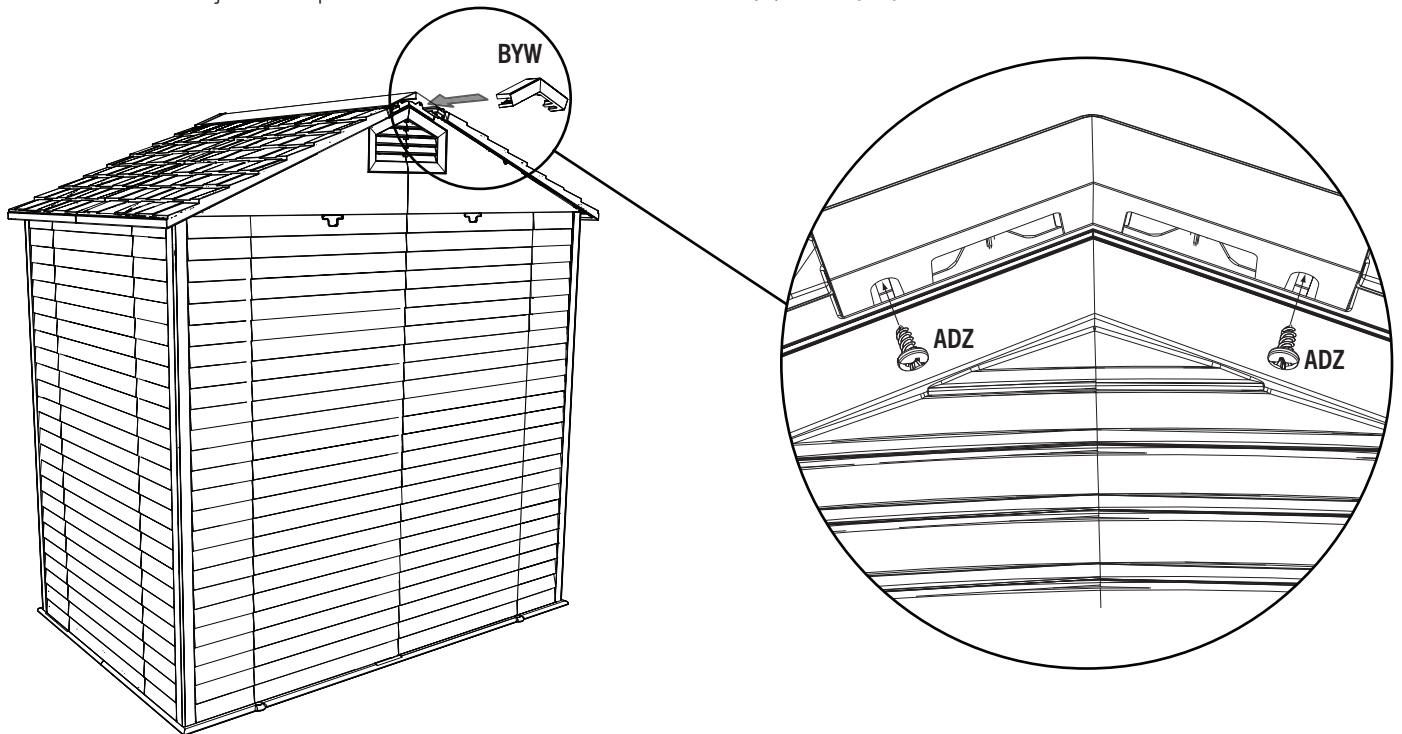

10.25

- Connect the end cap to the inside of the shed using two (2) screws (ADZ).
- Attacher le capuchon à l'intérieur de l'abri à l'aide de deux (2) vis (ADZ).
- Sujetar el tapón al interior de la caseta usando dos (2) tornillos (ADZ).

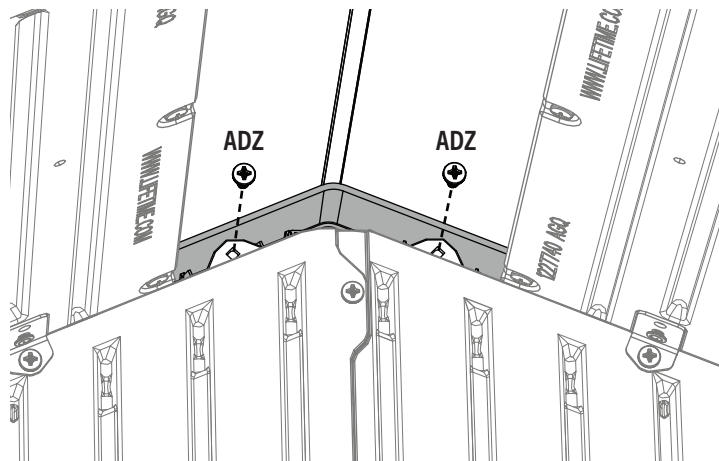

11

DOOR ALIGNMENT / ALIGNEMENT DES PORTES / ALINEACIÓN DE LAS PUERTAS



HARDWARE REQUIRED / QUINCAILLERIE REQUISE / HERRAJE REQUERIDO



PARTS REQUIRED / PIÈCES REQUISES / PIEZAS REQUERIDAS

Wood parts / Pièces en bois / Piezas de madera

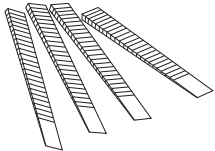

EUG (x4)



TOOLS REQUIRED / OUTILS REQUIS / INSTRUMENTAL REQUERIDO

(Not included—unless otherwise indicated*) / (Non inclus — sauf indication contraire*) / (No incluido, salvo indicación contraria*)

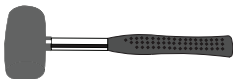

► SECTION 11 (CONTINUED) / SECTION 11 (SUITE) / SECCIÓN 11 (CONTINUACIÓN)

TOOLS AND HARDWARE REQUIRED / OUTILS ET QUINCAILLERIE REQUIS / INSTRUMENTAL Y HERRAJE REQUERIDOS



- If you have trouble with this section, follow the code below to view a video on the assembly in this section.
- Si vous avez des problèmes avec cette section, suivez le code en bas pour voir un vidéo sur l'assemblage dans cette section.
- Si tiene problemas con esta sección, siga el código debajo para ver un video sobre el ensamble en esta sección.



<http://go.lifetime.com/dooralignment7>

11.1

- If the doors are not level, follow the steps on the next page to even them out.
- Si les portes ne sont pas de niveau l'une avec l'autre, suivre les étapes sur la page suivante pour les niveler.
- Si las puertas no son niveladas, seguir los pasos en la página siguiente para nivelarlas.

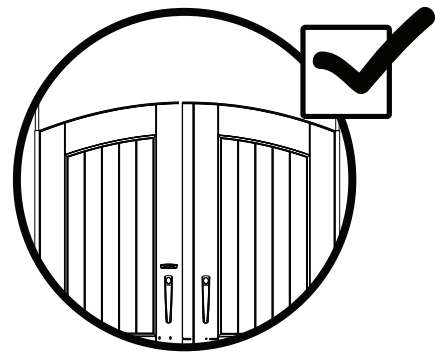

► SECTION 11 (CONTINUED) / SECTION 11 (SUITE) / SECCIÓN 11 (CONTINUACIÓN)

TOOLS AND HARDWARE REQUIRED / OUTILS ET QUINCAILLERIE REQUIS / INSTRUMENTAL Y HERRAJE REQUERIDOS



11.2

- If the left door is higher, follow this step.
- Si la porte gache est plus haute, suivre cette étape.
- Si la puerta izquierda es más alta, seguir este paso.

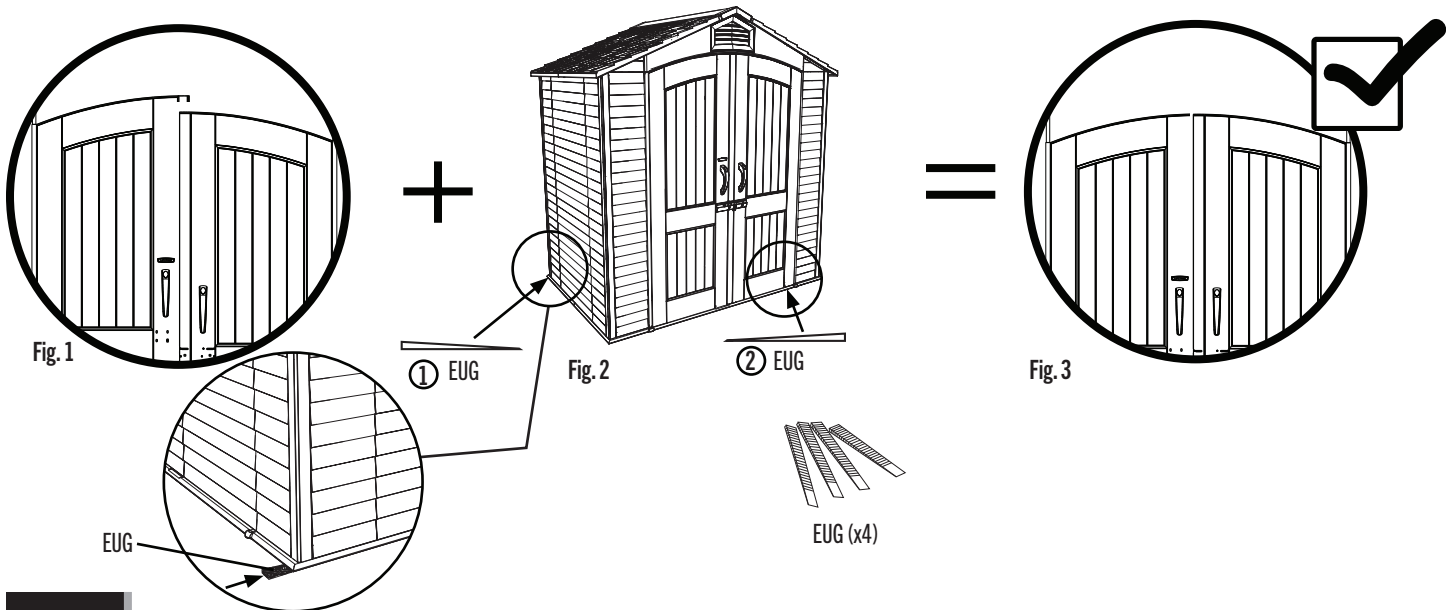

11.3

- If the right door is higher, follow this step.
- Si la porte droite est plus haute, suivre cette étape.
- Si la puerta derecha es más alta, seguir este paso.

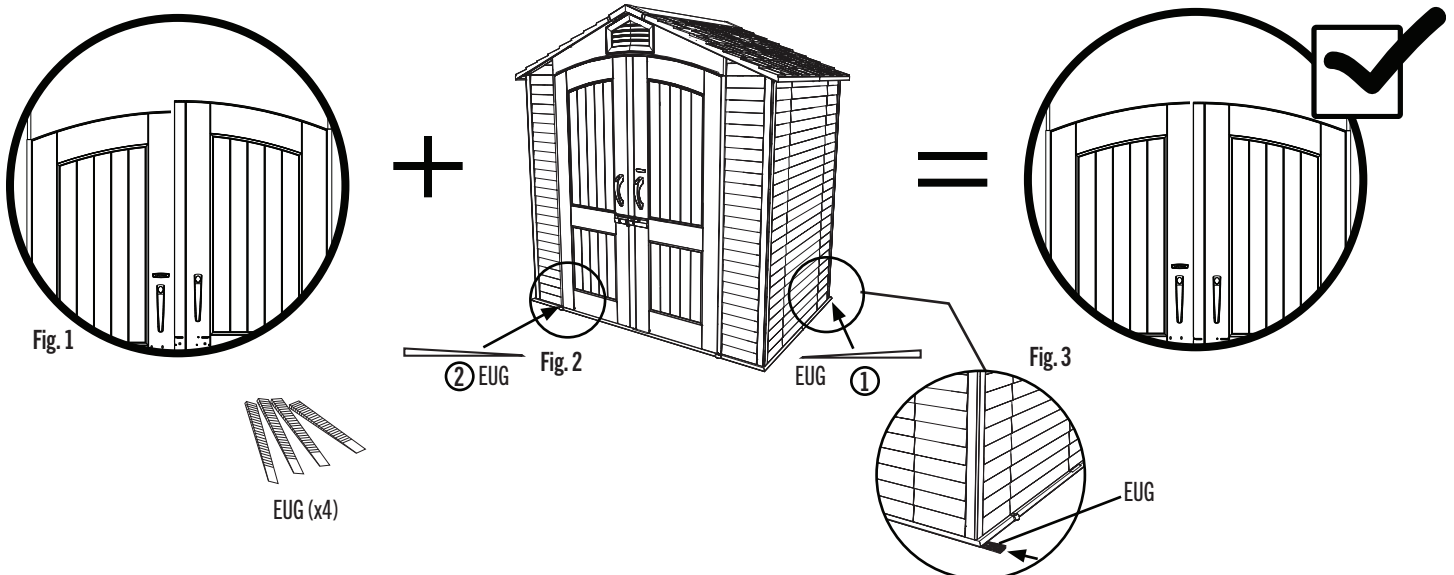



HARDWARE REQUIRED / QUINCAILLERIE REQUISE / HERRAJE REQUERIDO



PARTS REQUIRED / PIÈCES REQUISES / PIEZAS REQUERIDAS



TOOLS REQUIRED / OUTILS REQUIS / INSTRUMENTAL REQUERIDO

(Not included—unless otherwise indicated) / (Non inclus — sauf indication contraire*) / (No incluido, salvo indicación contraria*)*

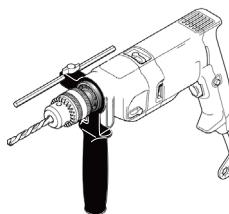

5/16 in/po (≈8 mm) Wood Drill Bit
 Foret à bois de 5/16 in/po (≈8 mm)
 Broca para madera de 5/16 in/po (≈8 mm)



5/16 in/po (≈8 mm) Masonry Drill Bit
 Foret à maçonnerie de 5/16 in/po (≈8 mm)
 Broca para albañilería de 5/16 in/po (≈8 mm)

▶ SECTION 12 (CONTINUED) / SECTION 12 (SUITE) / SECCIÓN 12 (CONTINUACIÓN)

TOOLS AND HARDWARE REQUIRED / OUTILS ET QUINCAILLERIE REQUIS / INSTRUMENTAL Y HERRAJE REQUERIDOS

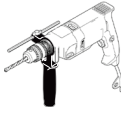

5/16 in/po
(≈8 mm)



12.1



- To anchor your shed, you must purchase the correct anchoring hardware. **For a concrete platform**, we recommend using a hammer drill, 5/16" (≈8 mm) masonry bit, four (4) 3/8" x 2" (≈10 mm x ≈5 cm) concrete screws and four (4) 3/8" x 1" (≈10 mm x ≈2,5 cm) fender washers. **Do not exceed a 3/8" (≈10 mm) diameter screw. Refer to your local hardware store for this hardware.**
- Pour ancrer l'abri, il faut acheter la quincaillerie d'ancrage correcte. **Pour une plate-forme en béton**, nous recommandons l'usage d'une perceuse de percussion, un foret à maçonnerie de ≈8 mm, quatre (4) vis d'ancrage à béton de ≈10 mm x ≈5 cm (3/8 po x 2 po), et quatre (4) rondelles de protection de ≈10 mm x ≈2,5 cm (3/8 po x 1 po). **Ne pas dépasser de diamètre de ≈10 mm (3/8 po). Une quincaillerie locale aura cette quincaillerie.**
- Para anclar la caseta, es necesario comprar el herraje de anclaje correcto. **Para una plataforma de concreto**, recomendamos el uso de un martillo perforador, una broca de albañilería de ≈8 mm, cuatro (4) tornillos de anclaje para concreto de ≈10 mm x ≈5 cm (3/8 in x 2 in), y cuatro (4) rondanas de protección de ≈10 mm x ≈2,5 cm (3/8 in x 1 in). **No exceder un diámetro de ≈10 mm (3/8 in). Referirse a su ferretería local para obtener este herraje.**

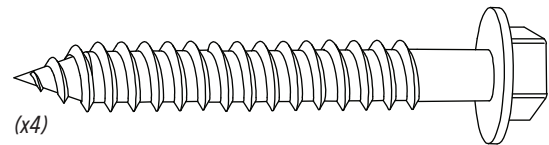
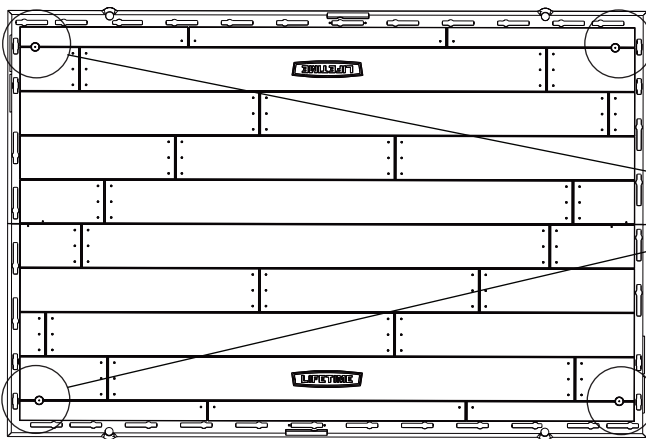

(x4)

(Not included) (Pas incluses) (No incluidos)

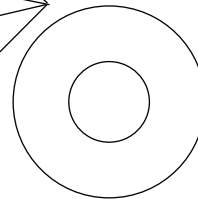

(x4)

(Not included) (Pas incluses) (No incluidas)



WARNING / AVERTISSEMENT / ADVERTENCIA



- Failure to anchor the shed may result in property damage and/or personal injury.
- Si vous n'ancrez pas votre abri, des dommages à la propriété et/ou des blessures peuvent en résulter.
- No anclar la caseta puede resultar en daños a la propiedad y/o en lesiones personales.

► SECTION 12 (CONTINUED) / SECTION 12 (SUITE) / SECCIÓN 12 (CONTINUACIÓN)

TOOLS AND HARDWARE REQUIRED / OUTILS ET QUINCAILLERIE REQUIS / INSTRUMENTAL Y HERRAJE REQUERIDOS



5/16 in/po
(≈8 mm)



12.1



- To anchor your shed, you must purchase the correct anchoring hardware. **For a wood-framed platform**, we recommend using a drill, 5/16" (≈8 mm) drill bit, four (4) 3/8" x 1 1/2" (≈10 mm x ≈4 cm) lag screws, and four (4) 3/8" x 1" (≈10 mm x ≈2,5 cm) fender washers. **Do not exceed a 3/8" (≈10 mm) diameter screw. Refer to your local hardware store for this hardware.**
- Pour ancrer l'abri, il faut acheter la quincaillerie d'ancrage correcte. **Pour une plate-forme en bois**, nous recommandons l'usage d'une perceuse électrique, un foret de ≈8 mm, quatre (4) vis de retard de ≈10 mm x ≈4 cm (3/8 po x 1 1/2 po), et quatre (4) rondelles de protection de ≈10 mm x ≈2,5 cm (3/8 po x 1 po). **Ne pas dépasser de diamètre de ≈10 mm (3/8 po). Une quincaillerie locale aura cette quincaillerie.**
- Para anclar la caseta, es necesario comprar el herraje de anclaje correcto. **Para una plataforma hecho de hecho de madera**, recomendamos el uso de un taladro eléctrico, una broca de ≈8 mm (5/16 in), cuatro (4) tornillos para madera de ≈10 mm x ≈4 cm (3/8 in x 1 1/2 in), y cuatro (4) rondanas de protección de ≈10 mm x ≈2,5 cm (3/8 in x 1 in). **No exceder un diámetro de ≈10 mm (3/8 in). Referirse a la ferretería local para obtener este herraje.**

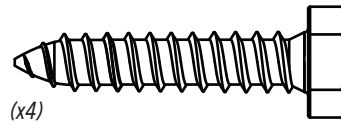
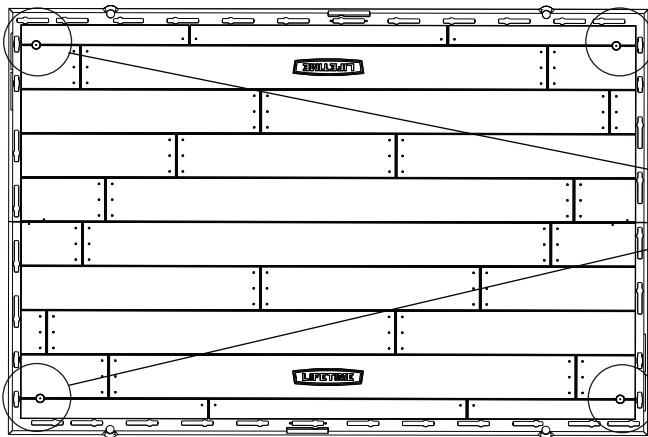

(x4)

(Not included) (Pas incluses) (No incluidos)

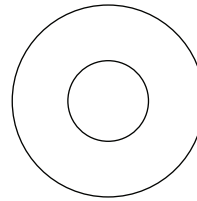

(x4)

(Not included) (Pas incluses) (No incluidas)



WARNING / AVERTISSEMENT / ADVERTENCIA



- Failure to anchor the shed may result in property damage and/or personal injury.
- Si vous n'ancrez pas votre abri, des dommages à la propriété et/ou des blessures peuvent en résulter.
- No anclar la caseta puede resultar en daños a la propiedad y/o en lesiones personales.



HARDWARE REQUIRED / QUINCAILLERIE REQUISE / HERRAJE REQUERIDO

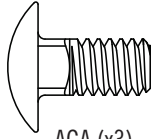

ACA (x3)

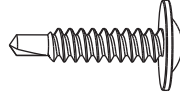

CHK (x2)

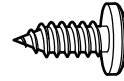

ADX (x9)

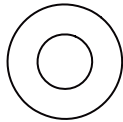

AEB (x3)

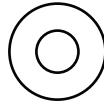

AEE (x9)

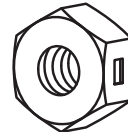

AAB (x3)

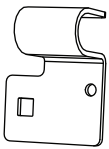

CVT (x1)

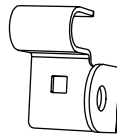

CVU (x1)



CVV (x1)

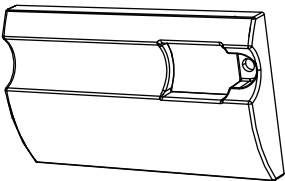

CVS (x1)



CVR (x1)

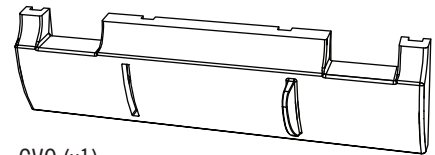

CVQ (x1)

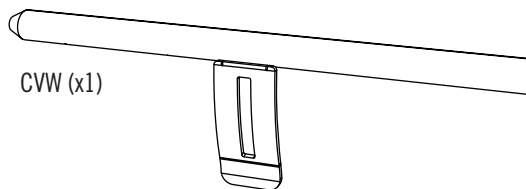

CVW (x1)



TOOLS REQUIRED / OUTILS REQUIS / INSTRUMENTAL REQUERIDO

(Not included—unless otherwise indicated) / (Non inclus — sauf indication contraire*) / (No incluido, salvo indicación contraria*)*



7/16 in/po (≈11 mm)



► SECTION 13 (CONTINUED) / SECTION 13 (SUITE) / SECCIÓN 13 (CONTINUACIÓN)

TOOLS AND HARDWARE REQUIRED / OUTILS ET QUINCAILLERIE REQUIS / INSTRUMENTAL Y HERRAJE REQUERIDOS

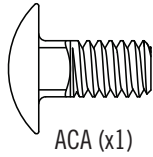

ACA (x1)

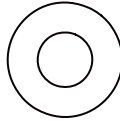

AEB (x1)

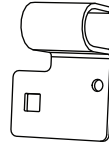

CVT (x1)

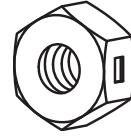

AAB (x1)



- If you have trouble with this section, follow the code below to view a video on the assembly in this section.
- Si vous avez des problèmes avec cette section, suivez le code en bas pour voir un vidéo sur l'assemblage dans cette section.
- Si tiene problemas con esta sección, siga el código debajo para ver un video sobre el ensamble en esta sección.

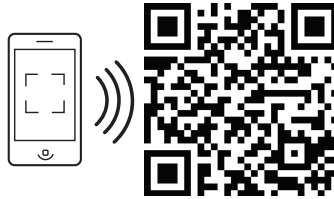

<http://go.lifetime.com/doorlatchslider>

13.1

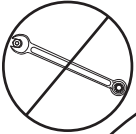

- Only after following the anchoring instructions, attach the **left latch bracket (CVT)** to the left door using the hardware provided. **Only hand tighten the nut at this point.**
- Seulement après avoir ancré votre abri, attachez le **support gauche du loquet (CVT)** à la porte gauche à l'aide de la quincaillerie incluse. **Ne serrer l'écrou que pour la main en ce moment.**
- Sólo después de haber seguido los pasos de anclaje, sujetar el **soporte izquierdo del pestillo (CVT)** a la puerta izquierda usando el herraje incluido. **Sólo apretar la tuerca a mano en este momento.**

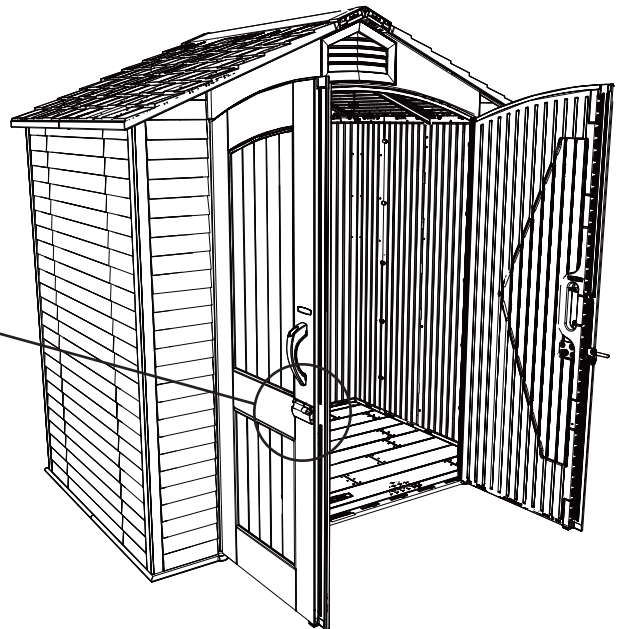
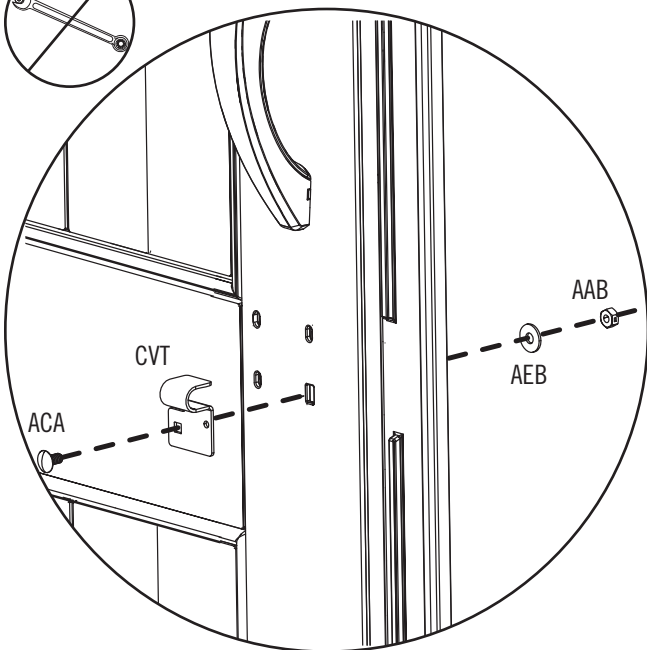

SECTION 13 (CONTINUED) / SECTION 13 (SUITE) / SECCIÓN 13 (CONTINUACIÓN)

TOOLS AND HARDWARE REQUIRED / OUTILS ET QUINCAILLERIE REQUIS / INSTRUMENTAL Y HERRAJE REQUERIDOS



7/16 in/po
(≈11 mm)

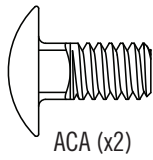

ACA (x2)

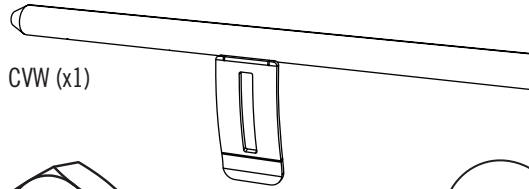

CVW (x1)

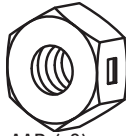

AAB (x2)

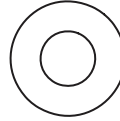

AEB (x2)

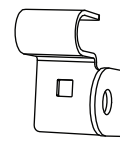

CVU (x1)

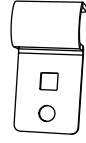

CVV (x1)

13.2

- Slide the **large right latch bracket (CVU)** and **small right latch bracket (CVV)** onto the **latch (CVW)** as shown.
- Faire glisser le **support droit grand du loquet (CVU)** et le **support droit petit du loquet (CVV)** sur le **loquet (CVW)** comme illustré.
- Deslizar el **sopORTE derecho grande del pestillo (CVU)** y el **sopORTE derecho pequeño del pestillo (CVV)** en el **pestillo (CVW)** como se muestra.

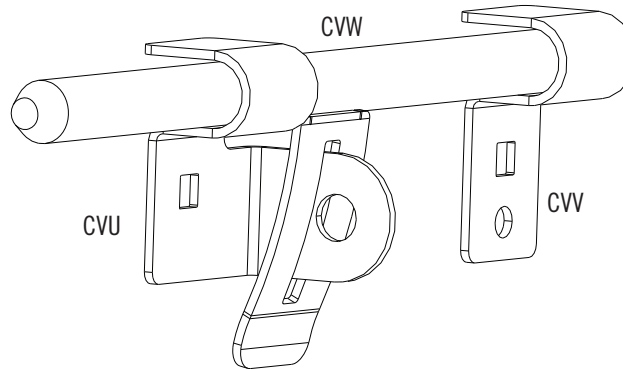

13.3

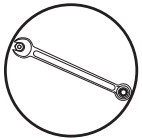

- Attach the latch assembly to the right door using the hardware provided. **Tighten these nuts securely.**
- Attacher l'ensemble du loquet à la porte droite à l'aide de la quincaillerie incluse. **Serrer bien ces écrous.**
- Sujetar el conjunto del pestillo a la puerta derecha usando el herraje incluido. **Apretar bien estas tuercas.**

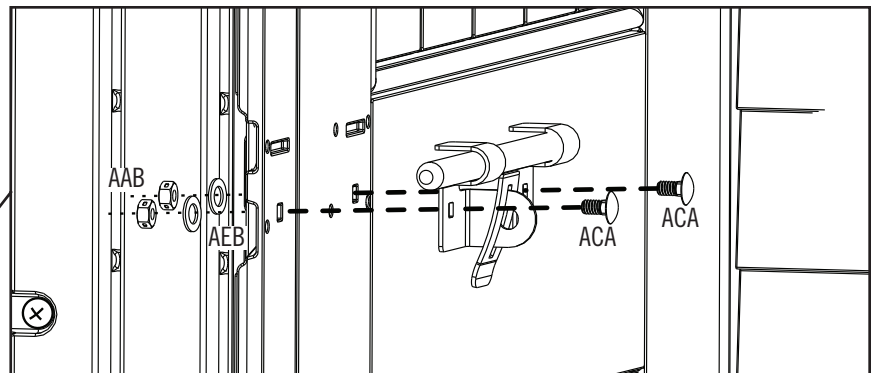
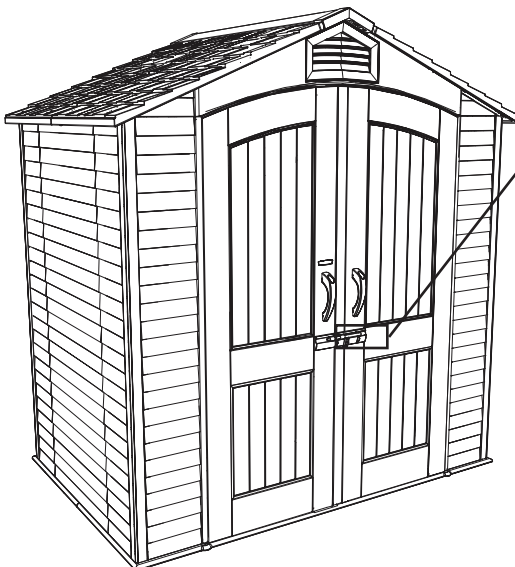

► SECTION 13 (CONTINUED) / SECTION 13 (SUITE) / SECCIÓN 13 (CONTINUACIÓN)

TOOLS AND HARDWARE REQUIRED / OUTILS ET QUINCAILLERIE REQUIS / INSTRUMENTAL Y HERRAJE REQUERIDOS

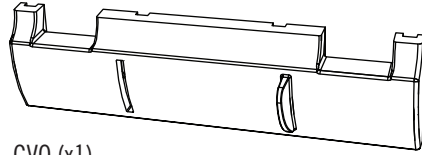

CVQ (x1)

13.4

- Slide the **large right cover plate (CVQ)** up under the latch assembly and rotate the latch downward to its locked position as shown.
- Faire glisser la **plaque couvrante grande droite (CVQ)** sous l'ensemble du loquet et tournez l'ensemble à sa position de verrouillage comme illustré.
- Deslizar la **placa cubrepestillo grande derecha (CVQ)** debajo el conjunto del pestillo y gire el pestillo en la posición de cierre como se muestra.

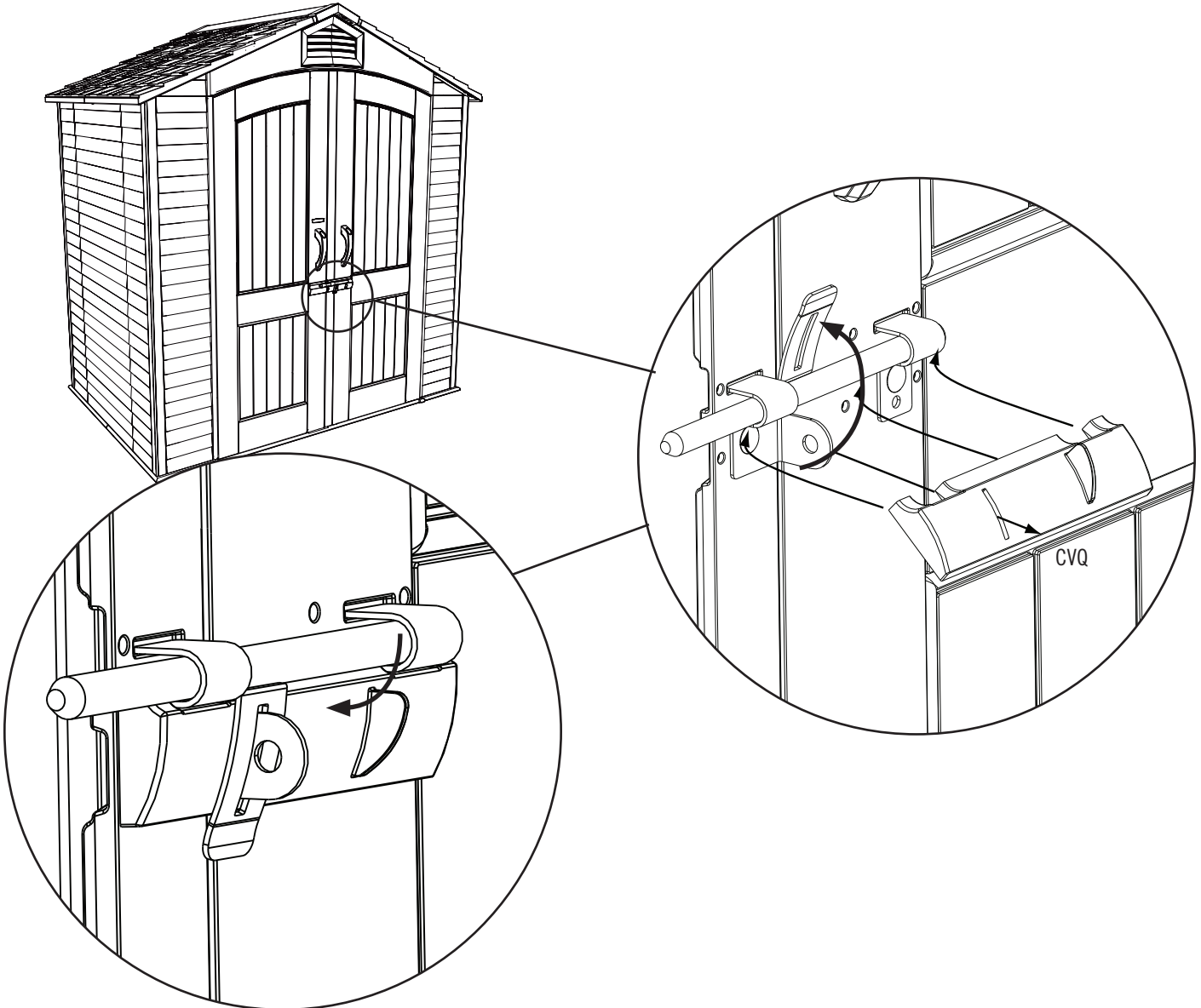

► SECTION 13 (CONTINUED) / SECTION 13 (SUITE) / SECCIÓN 13 (CONTINUACIÓN)

TOOLS AND HARDWARE REQUIRED / OUTILS ET QUINCAILLERIE REQUIS / INSTRUMENTAL Y HERRAJE REQUERIDOS

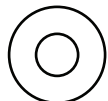

AEE (x3)

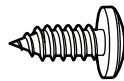

ADX (x3)

13.5

- Secure the large cover plate to the door as shown using the hardware provided.
- Attacher la plaque couvrante grande à la porte à l'aide de la quincaillerie incluse.
- Sujetar la placa cubrepestillo grande a la puerta usando el herraje incluido.

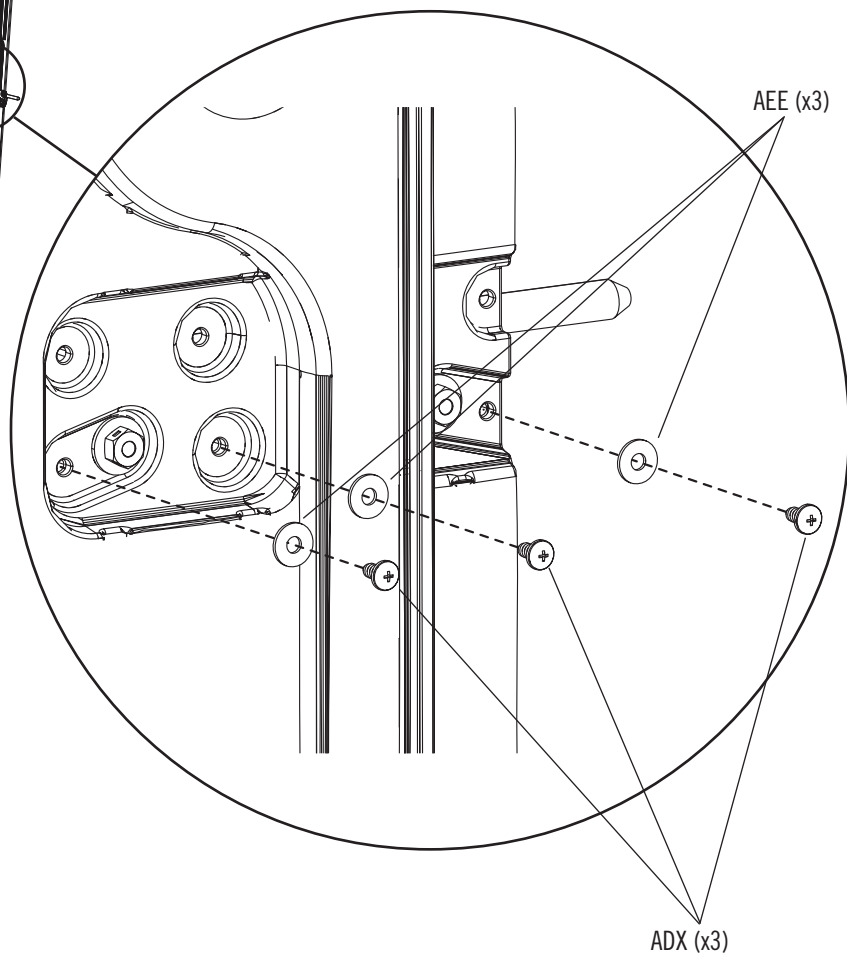
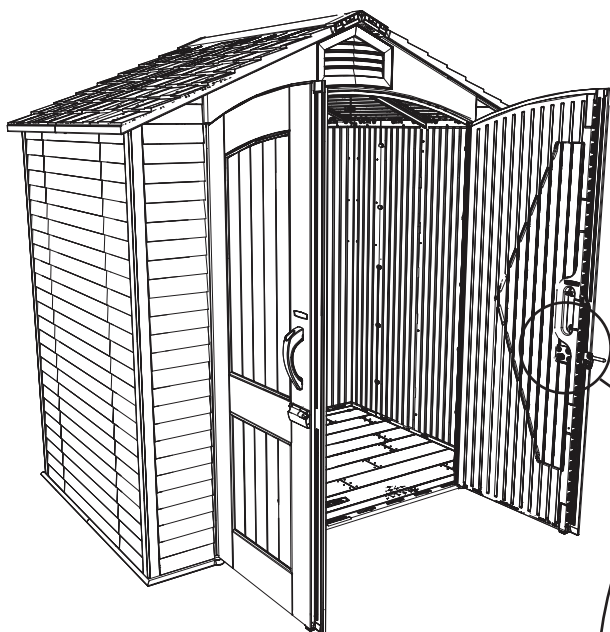

► SECTION 13 (CONTINUED) / SECTION 13 (SUITE) / SECCIÓN 13 (CONTINUACIÓN)

TOOLS AND HARDWARE REQUIRED / OUTILS ET QUINCAILLERIE REQUIS / INSTRUMENTAL Y HERRAJE REQUERIDOS



CVR (x1)

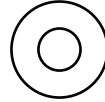

AEE (x3)

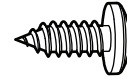

ADX (x3)

13.6

- Slide the **small right cover plate (CVR)** down under the latch assembly, and secure the cover plate to the door as shown using the hardware provided.
- Faire glisser la **petite plaque couvrante droite (CVR)** sous l'ensemble du loquet, et attacher la plaque à la porte à l'aide de la quincaillerie incluse.
- Deslizar la **placa cubrepestillo pequeña derecha (CVR)** debajo el conjunto del pestillo, y sujetar la placa a la puerta usando el herraje incluido.

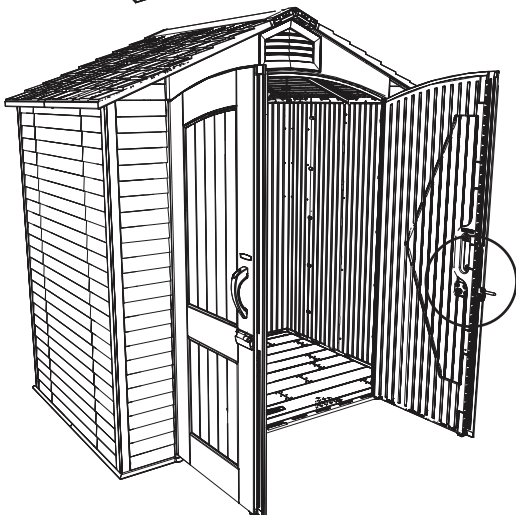
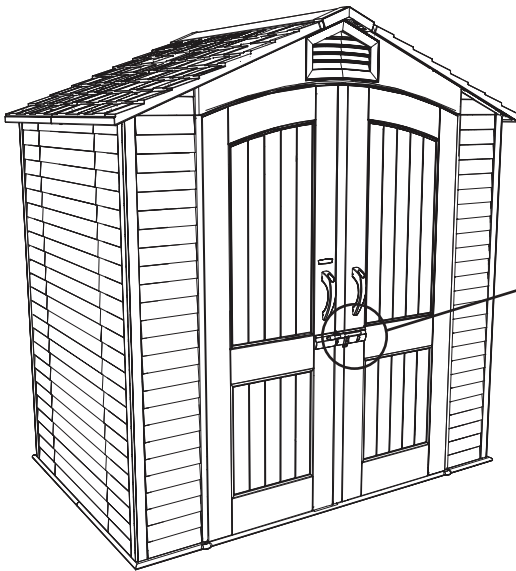
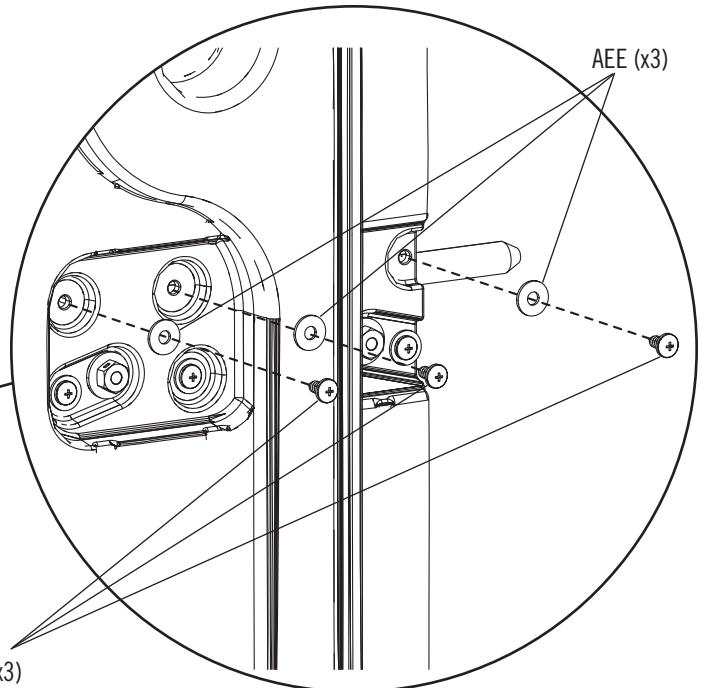
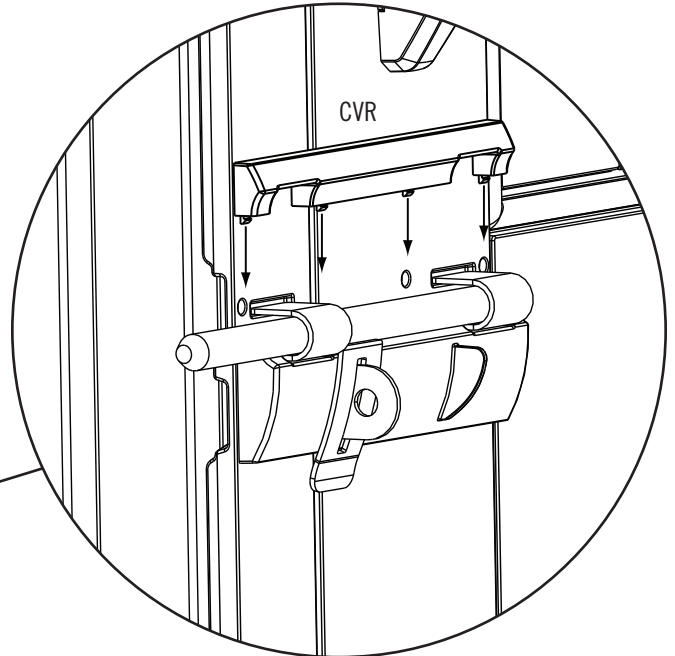

ADX (x3)

AEE (x3)

► SECTION 13 (CONTINUED) / SECTION 13 (SUITE) / SECCIÓN 13 (CONTINUACIÓN)

TOOLS AND HARDWARE REQUIRED / OUTILS ET QUINCAILLERIE REQUIS / INSTRUMENTAL Y HERRAJE REQUERIDOS



13.7

- Close both doors and lock the latch. Adjust the left latch bracket so the latch slides through freely.
- Fermer les deux portes et verrouillez le loquet. Ajuster le support gauche du loquet pour que le loquet verrouille librement.
- Cerrar las dos puertas y el pestillo. Ajustar el soporte izquierdo del pestillo para que el pestillo cierre libremente.

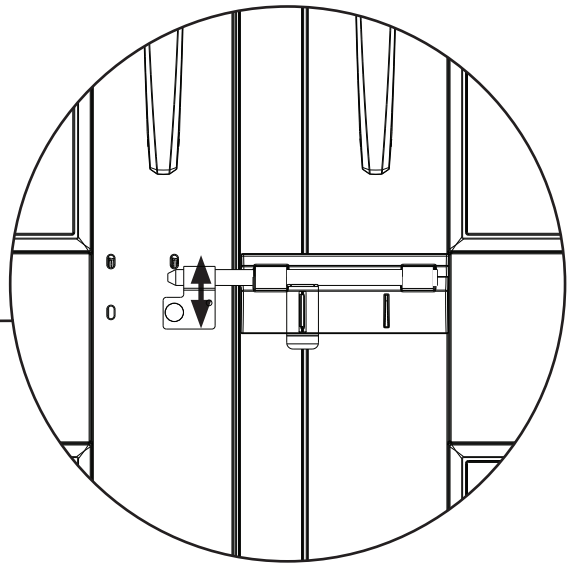
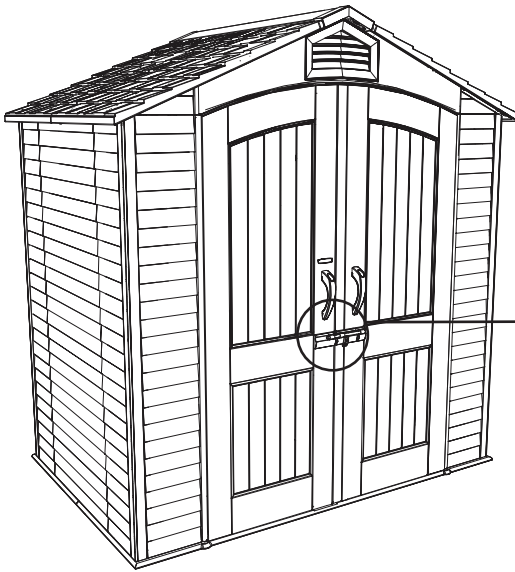

13.8

- Insert one (1) **self-drilling/self-tapping screw (CHK)** through the hole in the left latch bracket to secure it in place.
- Insérer une (1) **vis auto-perceuse/auto-taraudeuse (CHK)** à travers le trou dans le support gauche du loquet pour le fixer en place.
- Insertar un (1) **tornillo auto-perforante/auto-roscante (CHK)** a través del agujero en el soporte izquierdo del pestillo para fijarlo en su lugar.

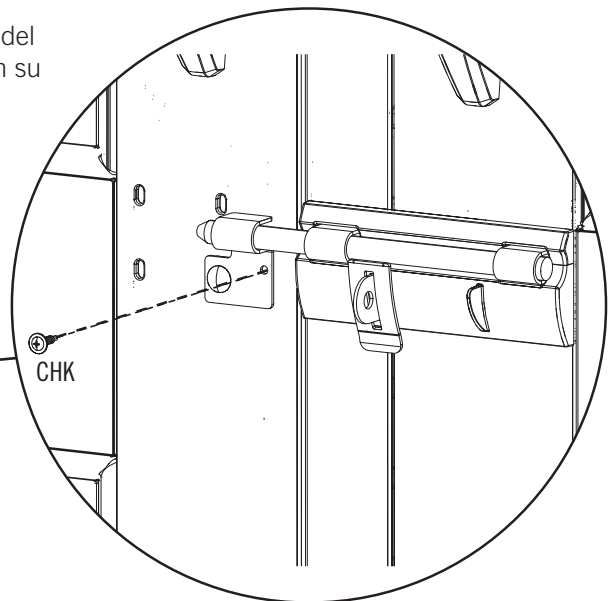
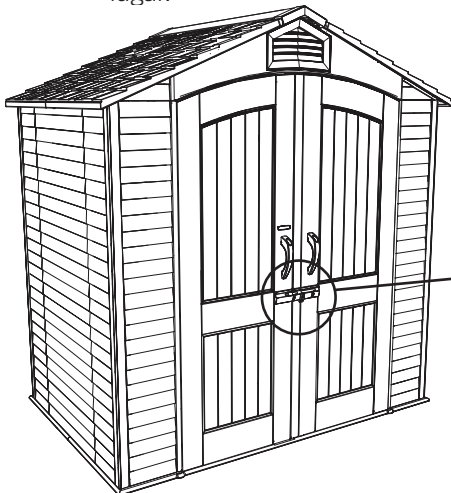

► SECTION 13 (CONTINUED) / SECTION 13 (SUITE) / SECCIÓN 13 (CONTINUACIÓN)

TOOLS AND HARDWARE REQUIRED / OUTILS ET QUINCAILLERIE REQUIS / INSTRUMENTAL Y HERRAJE REQUERIDOS



7/16 in/po
(≈11 mm)

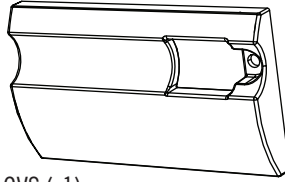

CVS (x1)

13.9

- Tighten the nut to the left latch bracket.
- Serrer bien l'écrou au support gauche du loquet.
- Apretar bien la tuerca al soporte izquierdo del pestillo.

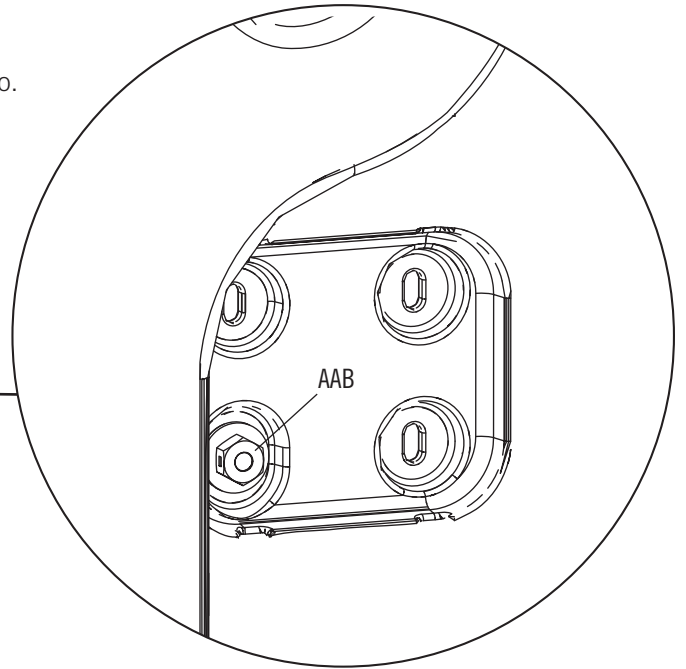
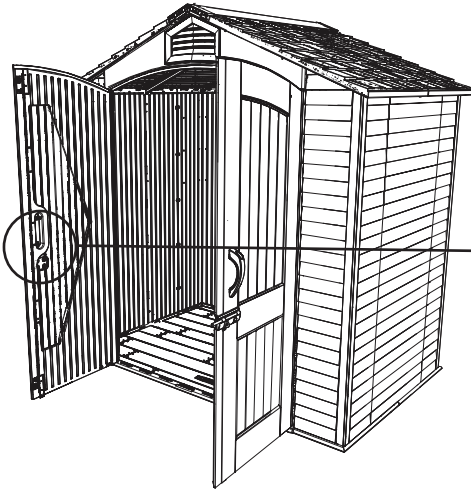

13.10

- Place **left cover plate (CVS)** over the left latch bracket.
- Mettre la **plaque couvrante gauche (CVS)** sur le support gauche du loquet.
- Colocar la **placa de cubierta izquierda (CVS)** encima del soporte izquierdo del pestillo.

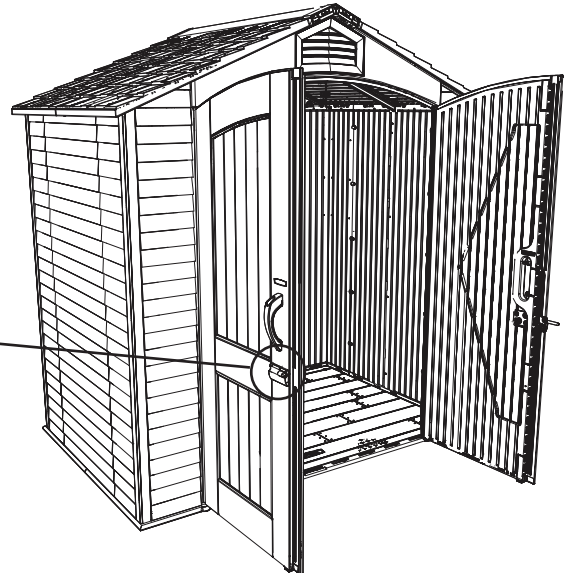
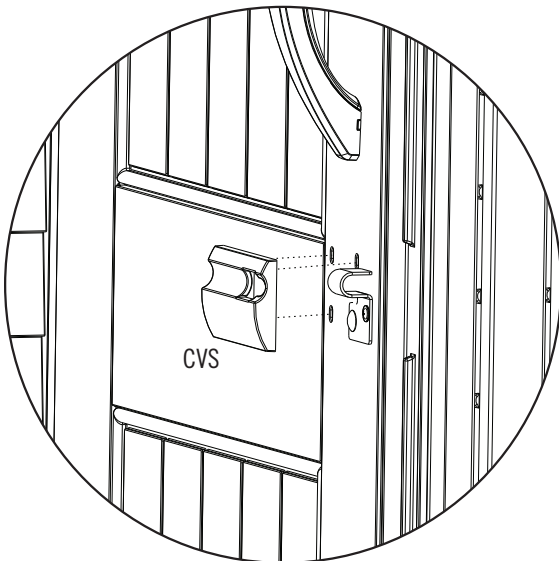

► SECTION 13 (CONTINUED) / SECTION 13 (SUITE) / SECCIÓN 13 (CONTINUACIÓN)

TOOLS AND HARDWARE REQUIRED / OUTILS ET QUINCAILLERIE REQUIS / INSTRUMENTAL Y HERRAJE REQUERIDOS

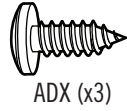

ADX (x3)

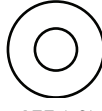

AEE (x3)

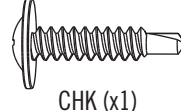

CHK (x1)

13.11

- Secure the left cover plate to the door as shown using the hardware provided.
- Attacher la plaque couvrante gauche à la porte à l'aide de la quincaillerie incluse.
- Sujetar la placa cubierta izquierda a la puerta usando el herraje incluido.

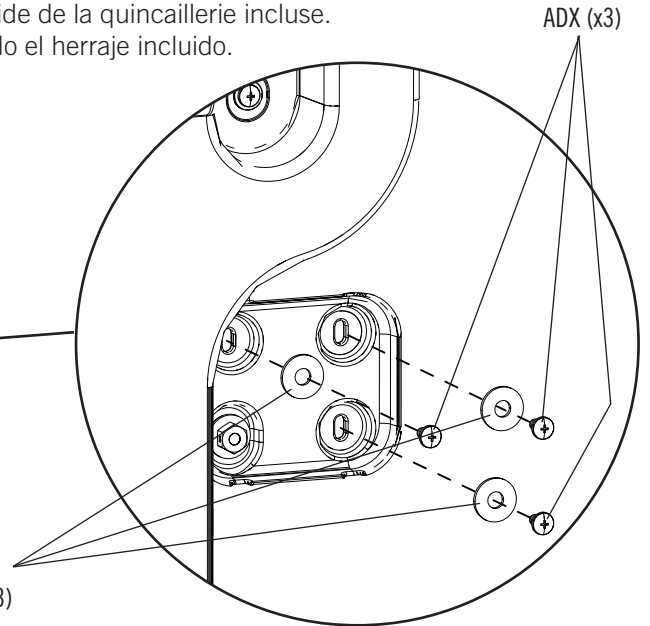

ADX (x3)

AEE (x3)

13.12

- Insert one (1) self-drilling/self-tapping screw (CHK) through the hole in the left cover plate to secure it in place.
- Insérer une (1) vis auto-perceuse/auto-taraudeuse (CHK) à travers le trou dans la plaque couvrante gauche pour la fixer en place.
- Insertar un (1) tornillo auto-perforante/auto-roscante (CHK) a través del agujero en la placa de cubierta izquierda para fijarla en su lugar.

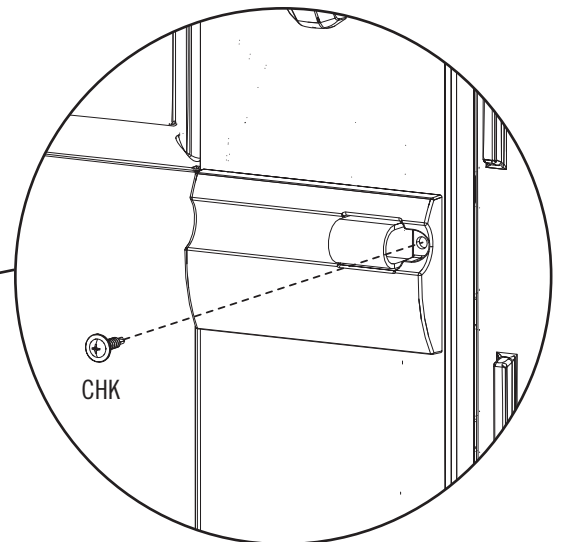
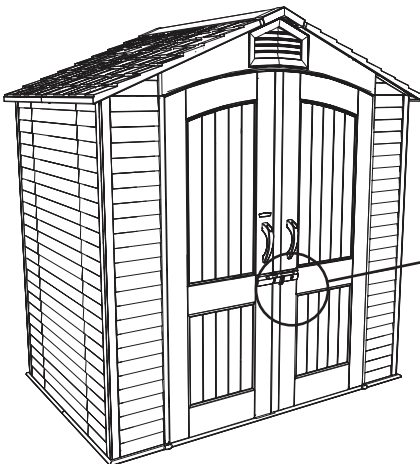

CHK



NOTES / REMARQUES / NOTAS

A large, empty white rectangular area intended for writing notes or remarks.



NOTES / REMARQUES / NOTAS

A large, empty white rectangular area intended for writing notes or remarks.



NOTES / REMARQUES / NOTAS

A large, empty white rectangular area intended for writing notes or remarks.

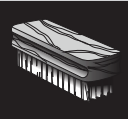

CLEANING & CARE

Congratulations on your Lifetime® product purchase. By following the instructions below, your new Lifetime product should provide you with years of service and enjoyment.

The polyethylene panels are stain and solvent resistant. Most stains can be removed using a mild soap and a soft-bristled brush. Abrasive cleaning materials may scratch the plastic and are not recommended. Repair scratches or rust spots on the metal by sanding the affected area lightly; using a rust preventative spray primer; and finally, spraying with a high-gloss spray enamel paint. Avoid placing a direct heat source on or near surfaces unless using a heat barrier.

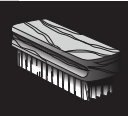

NETTOYAGE ET ENTRETIEN

Nous vous félicitons d'avoir acheté ce produit Lifetime®. En suivant les instructions ci-dessous, votre nouveau produit Lifetime devrait vous fournir des années de service et de plaisir.

Les murs et les étagères en polyéthylène sont résistants aux taches et solvants de nettoyage. Pour les nettoyer, se servir d'un savon doux et d'une brosse douce. Les produits abrasifs de nettoyage risquent d'égratigner le plastique et ne sont pas recommandés. Pour réparer les égratignures ou taches de rouille sur le métal, frotter légèrement l'endroit affecté au papier de verre, puis passer une couche de produit vaporisant préventif, et, enfin, vaporiser une peinture émail ultrabrillante. Éviter de placer une source de chaleur directe sur ou près des surfaces, ou les protéger à l'aide d'une protection contre la chaleur.



LIMPIEZA Y CUIDADO

Felicidades por la compra de su producto Lifetime®. Al seguir las siguientes instrucciones, su nuevo producto Lifetime le brindará años de servicio y satisfacción.

Los paneles de polietileno son resistentes a las manchas y solventes. La mayoría de las manchas puede removerse usando un jabón suave y un cepillo de cerdas suaves. Los materiales abrasivos para limpieza pueden rayar el plástico y no se recomiendan. Reparar rayones o manchas de óxido en el metal, lijando suavemente la parte afectada; usando un aerosol preventivo de óxido y finalmente, rociando con una pintura de esmalte brillante. Evitar poner una fuente de calor directa en o cerca de las superficies sin usar una barrera de calor.



REGISTER YOUR PRODUCT ONLINE AT WWW.LIFETIME.COM

At Lifetime®, we are committed to providing innovative and quality products. While registering, you will have the opportunity to give us your feedback. Your input is valuable to us.

- You can also opt in to receive new product notifications or promotions.
- In the unlikely event of a product recall or safety modification, your registration provides the information we need to notify you directly.
- Registration is fast, easy, and completely voluntary.

LIFETIME'S PROMISE TO YOU:

Maintaining your privacy is our long-standing policy at Lifetime®. And you can rest assured that Lifetime® will not sell or provide your personal data to other third parties, or allow them to use your personal data for their own purposes.

We invite you to read our privacy policy at www.lifetime.com

REGISTER today!



ENREGISTRER CE PRODUIT EN LIGNE À WWW.LIFETIME.COM

Chez Lifetime®, nous nous engageons à fournir des produits innovateurs de qualité. Lors de votre inscription, vous aurez l'occasion de nous faire parvenir vos commentaires. Votre opinion est importante pour nous.

- On peut également choisir de recevoir des avis ou des promotions dans le cadre de nouveaux produits.
- Dans l'éventualité improbable d'un rappel ou d'un avis de sécurité, l'inscription fournit les renseignements nécessaires nous permettant de communiquer avec vous.
- L'inscription est rapide, facile et complètement volontaire.

LA PROMESSE DE LIFETIME:

Conserver votre confidentialité est notre politique de longue date chez Lifetime®. Vous pouvez donc être rassuré par le fait que Lifetime® ne vendra pas ou ne fournira pas vos données personnelles à des tiers, et ne leur permettra pas d'utiliser vos données personnelles à leurs propres fins.

Nous vous invitons à lire notre politique de confidentialité à www.lifetime.com (en anglais seulement)

ENREGISTRER CE PRODUIT aujourd'hui!



REGISTRAR EL PRODUCTO EN LÍNEA EN WWW.LIFETIME.COM

En Lifetime®, estamos comprometidos a ofrecer productos innovadores y de calidad. Al registrarse, usted tendrá la oportunidad de darnos su retroalimentación. Su información es valiosa para nosotros.

- También puede optar por recibir nuestras notificaciones o promociones.
- En el caso improbable de que el producto deba ser retirado del mercado o que sufra alguna modificación, su registro provee la información que necesitamos para notificarle directamente.
- El registro es rápido, fácil y completamente voluntario.

LA PROMESA DE LIFETIME® PARA USTED:

Mantener privacidad es nuestra política permanente en Lifetime®. Y puede estar seguro que Lifetime® no venderá ni dará datos personales a terceros, ni les permitirá usar datos personales para sus propios fines.

Lo invitamos a leer nuestra política de privacidad en www.lifetime.com (sólo en inglés)

¡REGISTRARSE hoy mismo!



10-YEAR LIMITED FACTORY WARRANTY

THE MANUFACTURER RESERVES THE RIGHT TO MAKE SUBSTITUTIONS TO WARRANTY CLAIMS IF PARTS ARE UNAVAILABLE OR OBSOLETE.

Lifetime Lawn and Garden products are warranted to the original purchaser to be free from defects in material or workmanship for a period of 10 years from the date of original retail purchase. The word “defects” is defined as imperfections that impair the use of the product. Defects resulting from misuse, abuse or negligence will void this warranty. This warranty does not cover defects due to improper installation, alteration or accident. Lifetime recommends that no modifications be made to this product. This warranty does not cover damage caused by vandalism, rusting, “acts of nature”, natural disasters, normal wear and tear, or any other event beyond the control of the manufacturer.

This warranty is nontransferable and is expressly limited to the repair or replacement of defective products. If the product is defective within the terms of this warranty, Lifetime Products, Inc. will repair or replace defective parts at no cost to the purchaser. Shipping charges to and from the factory or distribution center are not covered and are the responsibility of the purchaser. Labor charges and related expenses for removal, installation or replacement of the product or its components are not covered under this warranty.

This warranty does not cover scratching, scuffing, or other cosmetic damage of the product that may result from normal usage. In addition, defects resulting from intentional damage, negligence, or unreasonable use will void this warranty / are not covered by this warranty.

Liability for incidental or consequential damages is excluded to the extent permitted by law. All merchandise is sold on this condition, and no representative of the company may waive or change this policy. This product is not intended for institutional or commercial use; Lifetime Products, Inc. does not assume any liability for such use. Institutional or commercial use will void the warranty.

This warranty is expressly in lieu of all other warranties, expressed or implied, including warranties of merchantability or fitness for use to extent permitted by Federal and state law. Neither Lifetime Products, Inc., nor any representative assumes any other liability in connection with this product. This warranty gives you specific legal rights, and you may also have other rights which vary from state to state.

AUSTRALIA : Our goods come with guarantees that cannot be excluded under the Australian Consumer Law. You are entitled to a replacement or refund for a major failure and for compensation for any other reasonably foreseeable loss or damage. You are also entitled to have the goods repaired or replaced if the goods fail to be of acceptable quality and the failure does not amount to a major failure.

**ALL WARRANTY CLAIMS MUST BE ACCOMPANIED BY A SALES RECEIPT.
REPORT PRODUCT DEFECTS IN WRITING TO:**

LIFETIME PRODUCTS, INC.,
PO Box 160010
Freeport Center, Bldg. D-12
Clearfield, UT 84016-0010

For online warranty claims, please visit: www.lifetime.com/warranty
Warranty Department: (800) 225-3865

FOR INTERNATIONAL WARRANTY:

All warranty claims must be accompanied by a sales receipt. Report product defects in writing to your regional sales support representative. Please include your dated sales receipt and photographs of damaged parts.

To Identify the representative for your region, please visit: www.lifetime.com/international



GARANTIE DE FABRICATION LIMITÉE DE 10 ANS

LIFETIME® PRODUCTS, INC. RÉSERVE LE DROIT DE FAIRE DES SUBSTITUTIONS EN CAS DE RECOURS EN GARANTIE SI LES PIÈCES NE SONT PAS DISPONIBLES OU SONT OBSOLÈTES.

L'acheteur d'origine des produits pour pelouses et jardins de Lifetime bénéficie d'une garantie contre toute défectuosité de matériel et de fabrication pour une période de 10 ans à compter de la date d'achat. On entend par « défaut » une imperfection qui nuit à l'utilisation du produit. Tout défaut découlant d'une mauvaise utilisation, d'un abus ou d'une négligence a pour effet d'annuler cette garantie. Cette garantie ne couvre pas les défauts attribuables à une installation inadéquate, une altération ou un accident. Lifetime recommande de ne pas apporter de modifications à ce produit. Cette garantie ne couvre pas les dommages causés par le vandalisme, la corrosion par la rouille, les cas de « force majeure », les catastrophes naturelles, la détérioration et l'usure normales et tout autre événement indépendant de la volonté du fabricant.

Cette garantie n'est pas transférable et se limite expressément à la réparation ou au remplacement d'un produit défectueux. Si le produit est défectueux au sens de cette garantie, Lifetime Products, Inc. réparera ou remplacera les pièces défectueuses sans frais pour l'acheteur. Les frais d'expédition en partance ou en provenance de l'usine ou du centre de distribution ne sont pas couverts et incombent à l'acheteur. Les coûts relatifs à la main-d'œuvre et les autres frais liés au retrait, à l'installation ou au remplacement du produit ou de ses composants ne sont pas couverts par cette garantie.

Cette garantie ne couvre pas les rayures, les égratignures ou autres dommages esthétiques du produit découlant d'un usage normal. De plus, tout défaut découlant d'un dommage volontaire, de négligence ou d'un usage déraisonnable annule cette garantie et n'est pas couvert par cette garantie.

Dans la mesure permise par la loi, la société n'est pas responsable des dommages indirects ou accessoires. Toute marchandise est vendue à cette condition et aucun représentant de la société ne peut renoncer à l'application de cette politique ou la modifier. Ce produit n'est pas destiné à des fins institutionnelles ou commerciales; Lifetime Products, Inc. n'assume aucune responsabilité à cet égard. Toute utilisation institutionnelle ou commerciale annule la garantie.

La présente garantie remplace expressément toute autre garantie, expresse ou implicite, y compris les garanties de qualité marchande ou d'adaptation à un usage particulier dans la mesure permise par les lois du pays ou de l'État. Ni Lifetime Products, Inc. ni aucun de ses représentants n'assument une quelconque responsabilité en lien avec ce produit. Cette garantie vous donne des droits juridiques précis et vous pourriez également avoir d'autres droits selon l'État ou la province.

AUSTRALIE: La garantie qui accompagne nos produits ne peut être exclue en vertu de la loi sur la protection du consommateur de l'Australie. Le client a droit à un remplacement ou à un remboursement en cas de bris majeur et pour toute autre perte ou dommage raisonnablement prévisible. Le client a aussi droit à ce que les produits soient réparés ou remplacés si un bris survient et rend la qualité inacceptable sans pour autant être qualifiable de bris majeur.

**TOUTE RÉCLAMATION EN VERTU DE LA GARANTIE DOIT ÊTRE ACCOMPAGNÉE D'UN REÇU DE VENTE.
SIGNALEMENT ÉCRIT DE TOUT PRODUIT DÉFECTUEUX:**

LIFETIME PRODUCTS, INC.,
PO Box 160010
Freeport Center, Bldg. D-12
Clearfield, UT 84016-0010

Pour effectuer en ligne une réclamation sous garantie, consultez cette adresse : www.lifetime.com/warranty
Service de la garantie : (800) 225-3865

GARANTIE INTERNATIONALE:

Toute réclamation en vertu de la garantie doit être accompagnée d'un reçu de vente. Veuillez signaler par écrit tout produit défectueux au représentant du soutien aux ventes de votre région. Veuillez inclure le reçu de vente daté ainsi que des photographies des pièces endommagées.

Pour connaître le représentant de votre région, veuillez consulter le : www.lifetime.com/international



GARANTÍA DE FÁBRICA LIMITADA POR 10 AÑOS

EL FABRICANTE SE RESERVA EL DERECHO DE HACER SUSTITUCIONES EN LOS ELEMENTOS REEMPLAZADOS BAJO GARANTÍA SI LAS PIEZAS NO ESTÁN DISPONIBLES O SON OBSOLETAS.

El comprador original recibe una garantía de que los productos de césped y jardín de Lifetime están libres de defectos de material o mano de obra durante un período de 10 años a partir de la fecha de compra original al por menor. La palabra “defectos” se define como imperfección que imposibilita el uso del producto. Los defectos ocasionados por el mal uso, el abuso o la negligencia anularán esta garantía. Esta garantía no cubre los defectos debidos a una instalación incorrecta, una alteración o un accidente. Lifetime recomienda que no se realicen modificaciones en este producto. Esta garantía no cubre los daños causados por vandalismo, oxidación, “actos de la naturaleza”, desastres naturales, desgaste normal o cualquier otro evento fuera del control del fabricante.

Esta garantía no es transferible y se limita expresamente a la reparación o reemplazo de productos defectuosos. Si el producto resulta defectuoso dentro de los términos de esta garantía, Lifetime Products, Inc. reparará o reemplazará las piezas defectuosas sin costo alguno para el comprador. Los gastos de envío hacia y desde la fábrica o el centro de distribución no están cubiertos y son la responsabilidad del comprador. La mano de obra y los gastos relacionados por la remoción, la instalación o la sustitución del producto o sus componentes no están cubiertos por esta garantía.

Esta garantía no cubre los rayones, los raspones ni otros daños superficiales del producto que pueden resultar del uso normal. Asimismo, los defectos resultantes de daños intencionales, negligencia o uso indebido anularán o no están cubiertos por esta garantía.

Se excluye la responsabilidad por daños imprevistos o derivados en la medida en que lo permita la ley. Toda la mercancía se vende bajo estas condiciones y ningún representante de la empresa puede renunciar a ni cambiar esta política. Este producto no está destinado para uso institucional o comercial; Lifetime Products, Inc. no asume ninguna responsabilidad por dicho uso. El uso institucional o comercial anulará la garantía.

Esta garantía sustituye expresamente cualquier otra garantía, expresa o implícita, incluidas las garantías de comercialización o idoneidad para su uso en la medida permitida por la ley federal y estatal. Ni Lifetime Products, Inc., ni ningún representante asume ninguna otra responsabilidad en relación con este producto. Esta garantía le otorga derechos legales específicos y usted también puede tener otros derechos que varían de un estado a otro.

AUSTRALIA : Nuestros productos vienen con garantías que no se pueden excluir bajo la Ley Australiana del Consumidor. Usted tiene derecho a recibir un reemplazo o reembolso por un fallo grave y compensación por cualquier otra pérdida o daño razonablemente previsible. También tiene derecho a la reparación o el reemplazo de los bienes si los bienes no son de calidad aceptable y el fallo no supone un fallo grave.

TODOS LOS RECLAMOS DE GARANTÍA DEBEN ESTAR ACOMPAÑADOS POR UN RECIBO DE COMPRA. REPORTE LOS DEFECTOS DEL PRODUCTO POR ESCRITO A:

LIFETIME PRODUCTS, INC.,
PO Box 160010
Freeport Center, Bldg. D-12
Clearfield, UT 84016-0010

Para realizar reclamos de garantía por internet, visite: www.lifetime.com/warranty.
Departamento de Garantías: (800) 225-3865

PARA LA GARANTÍA INTERNACIONAL:

Todos los reclamos de garantía deben estar acompañados por un recibo de compra. Reporte los defectos del producto por escrito a su representante regional de apoyo de ventas. Por favor, incluya su recibo de compra con la fecha y fotografías de las piezas dañadas.

Para identificar al representante de su región, por favor visite: www.lifetime.com/international

GARANTIA NO VÁLIDA EN MÉXICO

ENHANCE YOUR LIFETIME® PURCHASE BY ADDING ACCESSORIES OR OTHER GREAT PRODUCTS

To purchase accessories or other Lifetime® products, visit us at:

www.lifetime.com

Or call: 1-800-424-3865

AMÉLIORER L'ACHAT LIFETIME® EN AJOUTANT DES ACCESSOIRES OU D'AUTRES PRODUITS

Pour acheter des accessoires ou des autres produits Lifetime®, visiter le :

www.lifetime.com

Ou composer le 1-800-424-3865

MEJORAR LA COMPRA DE LIFETIME® AGREGANDO ACCESORIOS U OTROS MARAVILLOSOS PRODUCTOS

Para comprar accesorios u otros productos de Lifetime®, visitarnos en:

www.lifetime.com

O marcar al 1-800-424-3865



www.lifetime.com

