

GUILD 650W Planer

Instruction Manual

PPL650G

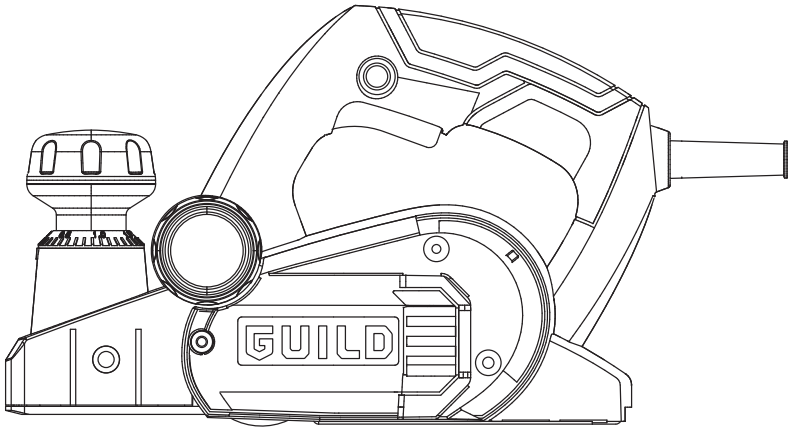

GUILD

After Sales Support

UK/Ireland 0333 3201989
Help@guildpowertools.co.uk

Important - Please read these instructions fully before operating or maintaining your Guild planer

These instructions contain important information that will help you get the best from your Guild planer, ensuring it remains safe to operate.

If you need help or have damaged or missing parts, call the Customer Helpline on 0333 3201989

Contents

Safety Information.....	3
In The Box.....	7
Accessories.....	7
Operating Instructions.....	10
Maintenance.....	15
Technical Data.....	15
Environmental Protection.....	16
Guarantee.....	17
Declaration of Conformity.....	17
Plug Replacement (Uk & Ireland Only).....	18

Safety Information

Important - Please read these instructions fully before starting assembly

Warning Symbols

The following warning symbols appear throughout this assembly manual and indicate the appropriate safety measures you should take when assembling and operating the guild planer.



To reduce the risk of injury, Please read the instruction manual



Warning



Wear ear protection



Wear eye protection



Wear dust mask



Double insulation



Waste electrical products must not be disposed of with household waste. Please recycle where facilities exist. Check with your local authorities or retailer for recycling advice.

Safety Information

Important - Please read these instructions fully before starting assembly

General Power Tool Safety Warnings



WARNING! Read all safety warnings and all instructions. Failure to follow the warnings and instructions may result in electric shock, fire and/or serious injury.

Save all warnings and instructions for future reference.

The term "power tool" in the warnings refers to your mains-operated (corded) power tool or battery-operated (cordless) power tool.

1) Work area safety

- a) **Keep work area clean and well lit.** Cluttered or dark areas invite accidents.
- b) **Do not operate power tools in explosive atmospheres, such as in the presence of flammable liquids, gases or dust.** Power tools create sparks which may ignite the dust or fumes.
- c) **Keep children and bystanders away while operating a power tool.** Distractions can cause you to lose control.

2) Electrical safety

- a) **Power tool plugs must match the outlet. Never modify the plug in any way. Do not use any adapter plugs with earthed (grounded) power tools.** Unmodified plugs and matching outlets will reduce risk of electric shock.
- b) **Avoid body contact with earthed or grounded surfaces, such as pipes, radiators, ranges and refrigerators.** There is an increased risk of electric shock if your body is earthed or grounded.
- c) **Do not expose power tools to rain or wet conditions.** Water entering a power tool will increase the risk of electric shock.
- d) **Do not abuse the cord. Never use the cord for carrying, pulling or unplugging the power tool. Keep cord away from heat, oil, sharp edges or moving parts.** Damaged or entangled cords increase the risk of electric shock.
- e) **When operating a power tool outdoors, use an extension cord suitable for outdoor use.** Use of a cord suitable for outdoor use reduces the risk of electric shock.
- f) **If operating a power tool in a damp location is unavoidable, use a residual current device (RCD) protected supply.** Use of an RCD reduces the risk of electric shock.

3) Personal safety

- a) **Stay alert, watch what you are doing and use common sense when operating a power tool. Do not use a power tool while you are tired or under the influence of drugs, alcohol or medication.** A moment of inattention while operating power tools may result in serious personal injury.
- b) **Use personal protective equipment. Always wear eye protection.** Protective equipment such as dust mask, non-skid safety shoes, hard hat, or hearing protection used for appropriate conditions will reduce personal injuries.
- c) **Prevent unintentional starting. Ensure the switch is in the off-position before connecting to power source and/or battery pack, picking up or carrying the tool.** Carrying power tools with your finger on the switch or energising power tools that have the switch on invites accidents.

Safety Information

Important - Please read these instructions fully before starting assembly

General Power Tool Safety Warnings

- d) **Remove any adjusting key or wrench before turning the power tool on.** A wrench or a key left attached to a rotating part of the power tool may result in personal injury.
- e) **Do not overreach. Keep proper footing and balance at all times.** This enables better control of the power tool in unexpected situations.
- f) **Dress properly. Do not wear loose clothing or jewellery. Keep your hair, clothing and gloves away from moving parts.** Loose clothes, jewellery or long hair can be caught in moving parts.
- g) **If devices are provided for the connection of dust extraction and collection facilities, ensure these are connected and properly used.** Use of dust collection can reduce dust-related hazards.

4) Power tool use and care

- a) **Do not force the power tool. Use the correct power tool for your application.**
The correct power tool will do the job better and safer at the rate for which it was designed.
- b) **Do not use the power tool if the switch does not turn it on and off.** Any power tool that cannot be controlled with the switch is dangerous and must be repaired.
- c) **Disconnect the plug from the power source and/or the battery pack from the power tool before making any adjustments, changing accessories, or storing power tools.** Such preventive safety measures reduce the risk of starting the power tool accidentally.
- d) **Store idle power tools out of the reach of children and do not allow persons unfamiliar with the power tool or these instructions to operate the power tool.**
Power tools are dangerous in the hands of untrained users.
- e) **Maintain power tools. Check for misalignment or binding of moving parts, breakage of parts and any other condition that may affect the power tool's operation. If damaged, have the power tool repaired before use.** Many accidents are caused by poorly maintained power tools.
- f) **Keep cutting tools sharp and clean.** Properly maintained cutting tools with sharp cutting edges are less likely to bind and are easier to control.
- g) **Use the power tool, accessories and tool bits etc. in accordance with these instructions, taking into account the working conditions and the work to be performed.** Use of the power tool for operations different from those intended could result in a hazardous situation.

5) Service

Have your power tool serviced by a qualified repair person using only identical replacement parts. This will ensure that the safety of the power tool is maintained.

Safety Information

Important - Please read these instructions fully before starting assembly

Planer Safety Warnings

1. **Wait for the cutter to stop before setting the tool down.** An exposed rotating cutter may engage the surface leading to possible loss of control and serious injury. Note The above warning applies only to planers without an automatic closing guard.
2. **Hold the power tool by insulated gripping surfaces only, because the cutter may contact its own cord.** Cutting a "live" wire may make exposed metal parts of the power tool "live" and could give the operator an electric shock.
3. **Use clamps or another practical way to secure and support the workpiece to a stable platform.** Holding the work by your hand or against the body leaves it unstable and may lead to loss of control.

Additional safety rules for planner

1. **Always wear a dust mask.**

In The Box

Parts

- 1 On/off switch
- 2 Lock-off switch
- 3 Hand grip areas
- 4 Dust extraction cover
- 5 Belt cover
- 6 Fastening screw
- 7 Parallel guide
- 8 Base plate
- 9 V-grooves
- 10 Rebate guide
- 11 Rebate guide fastening screw (2pcs)
- 12 Cutting depth Scale
- 13 Cutting depth adjustment knob
- 14 Dust bag (SEE FIG I)
- 15 Blade(SEE FIG K)
- 16 Blade clamp (SEE FIG K)
- 17 Spanner (SEE FIG K)
- 18 Large pulley (SEE FIG O)
- 19 Pinion (SEE FIG O)

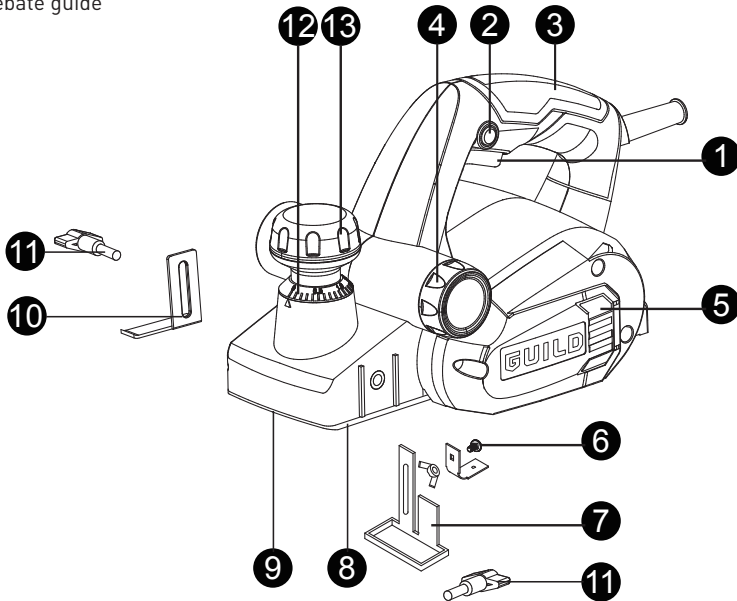

Accessories

Parallel guide
Rebate guide
Blades (on tool)
Spanner
Dust bag

1pc
1pc
2pc
1pc
1pc

Operating Instructions



NOTE: Before using the tool, read the instruction book carefully.

Intended Use

The tool is intended for planing of firmly supported wooden materials, such as beams and boards. It is also suitable for beveling edges and rebating.

1. SAFETY ON/OFF SWITCH (SEE FIG A)

The switch is locked off to prevent accidental starting. Depress the lock off button then the on/off switch and release the lock off button. To switch off, just release the on/off switch.



WARNING: Danger of kickback! Apply the tool to the work piece only when switched on.

2. CUTTING DEPTH ADJUSTMENT (SEE FIG B)

The planing depth can be adjusted from 0 to 2mm. Rotate the cutting depth adjustment knob (12) to set the required cutting depth with the scale (11). Clockwise rotation increases the planing depth; anticlockwise rotation reduces the planing depth.

It is recommended that test cuts be made in scrap wood after each adjustment to make sure that desired amount of wood is being removed by your planer.

NOTE: To protect blades during storage, transporting, etc., set blade depth adjustment knob to 0.

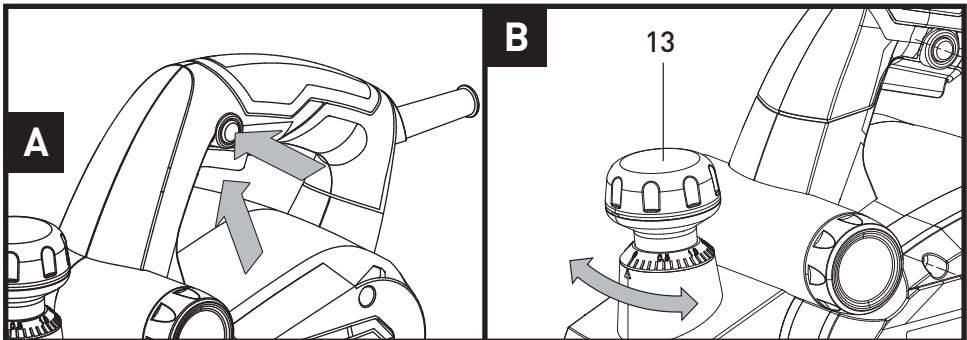

Operating Instructions

3. STANDARD SURFACE PLANING (SEE FIG C)

Set the desired cutting depth. Position the front part of the base plate flat onto the work surface. Make sure that the blades are not touching the workpiece. Switch the tool on and push your planer forward and it will start cutting. Always maintain all of the base plate flat on the work surface to prevent the cutting blade jumping. Move the plane evenly over the work surface.

Be careful to avoid hitting nails during operation. It could nick, crack, or damage blades. We suggest that you always keep an extra set of blades on hand for replacement.

4. EDGE CHAMFERING (SEE FIG D, E)

⚠ CAUTION: Always use both hands on the tool for any operation. It assures to maintain control and avoid the risk of serious personal injury. The workpiece must always be properly supported and clamped so that both hands will be free to control the planer.

Using the V-groove (9) in the base plate you can make a chamfer on the work piece edge. Guide the planer along the edge and maintain a constant angle and force to produce a good finish. You can control the angle of the chamfer with your hands. Make a test chamfer on a scrap piece of wood. Maintain downward pressure to keep your planer flat at the beginning and the end of the work surface.

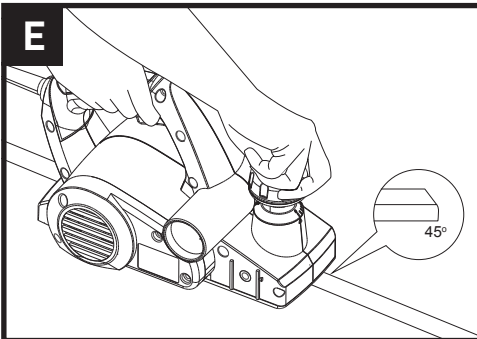
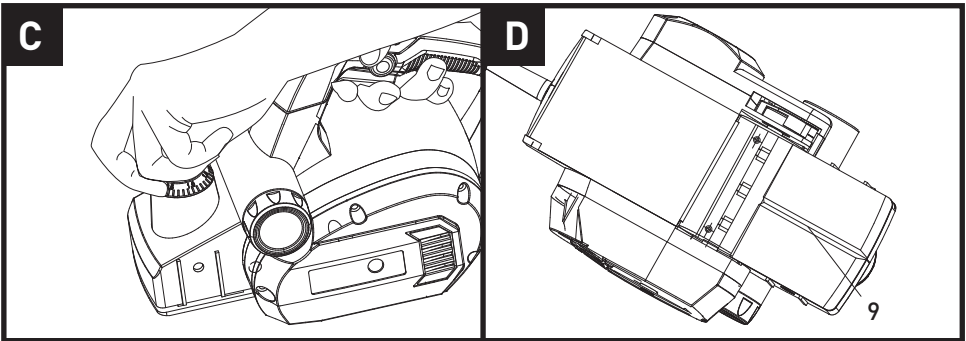

Operating Instructions

5. USING THE PARALLEL GUIDE (SEE FIG F)

Insert the screw provided through the hole on the support of parallel guide (7). Turn the screw into the nut on the housing. Fix the parallel guide on the support of parallel guide with the screw and nut. Ensure the screws are tightened securely.

NOTE: The parallel guide should be fitted on the left of housing.

To adjust the required width of cut, loosen the nut and slide the parallel guide to the required position. Retighten the nut fully.

Use the parallel guide while cutting. The guide should be held firmly against the edge of the workpiece.

6. USING THE REBATE (SEE FIG G)

Insert the screw (11) provided through the slot on the Rebate. Turn the screw into the nut on the housing.

The cut depth adjustment can be set from 0 to 10mm.

To adjust the depth of cut, place the planer on a flat board, then loosen the screw and slide the cut depth adjustment guide up and down for required depth. Tighten the thumb screw fully.

7. REBATING (SEE FIG H)

The width of rebating cut (a) is adjustable by moving the parallel guide. The depth of rebating cut (b) is determined by moving the Rebate, and the number of passes made along the workpiece. Make sure that the plane is guided with a lateral supporting pressure.

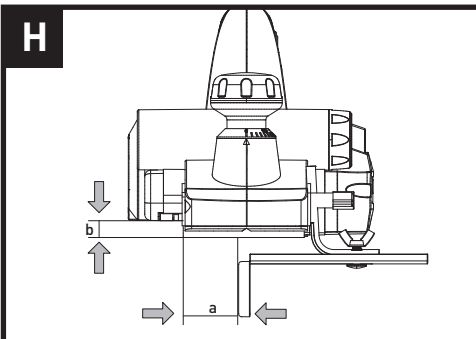
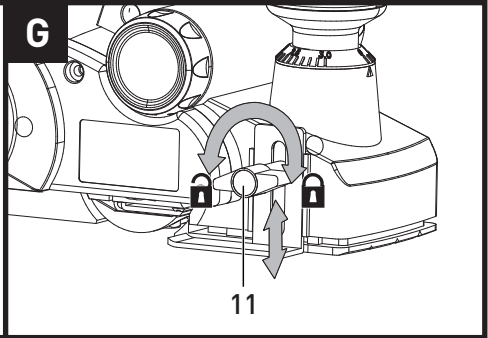
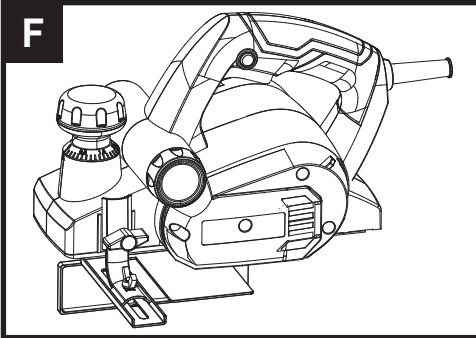

Operating Instructions

8. USING THE DUST BAG (SEE FIG I)

Your planer is equipped with a dust bag for collection of wood chips in the work area. Make sure the zipper on the bag is fully closed. To fit the dust bag, simply insert the tube end of the bag into the dust extraction outlet. There are two dust extraction outlets on opposite sides, and the dust bag can be inserted into either one, with the other covered by the dust extraction cover. Then switch on and start planing.

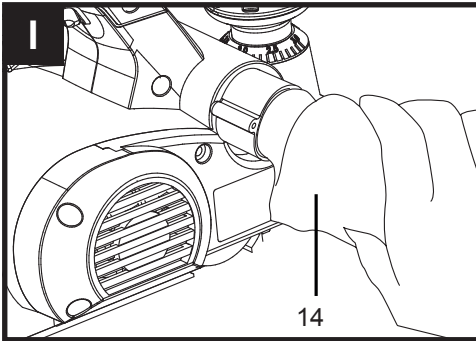

CLEANING DUST EXHAUST OUTLET AND EMPTYING THE DUST BAG

After using your planer for an extended period of time or when planing wet green timber, chips may build-up in the dust exhaust outlet and require clearing. Chip build-up restricts air flow and causes the motor to overheat. Turn off the planer and remove the dust bag from the dust exhaust outlet. Clean the chip and dust exhaust outlet of your planer with a small piece of wood. Do not use your hands or fingers. Unzip the dust bag and empty all chips from it. Ensure collar is free from debris.

We recommend emptying the dust bag every 3-6 minutes.

Operating Instructions

9. BLADE FITTING AND CHANGING (SEE FIG J, K, L, M)

NOTE: Dull and worn blade cannot be reground and must be replaced. Always replace blades in pairs.

⚠ WARNING: Remove power cord from the socket before carrying out any adjustments or changing blades. Always put on gloves when replacing blades.

Using the blade spanner provided to loosen the three installation screws approximately 1/2 rotation anticlockwise.

NOTE: Do not over-loosen the screws. If the screws are too loose, the alignment of the new blade will not be accurate.

Before removing the old blades, take notice of the direction of cut as well as how the tapered edge of the old blades are oriented. The tapered edge of the new blades must be in the same orientation as the original blades.

Press the safety cover down with your finger. Push the blade out with the tip of a spanner (or a screwdriver) and then remove.

NOTE: There is no need to remove the blade clamp as this will change the factory settings for cutting blade height control.

NOTE: If a blade cannot be pushed out easily after loosening the screws, use a piece of wood to break the blade loose from the blade clamp, with a short sharp blow. Then push with a screwdriver to remove the blades. If necessary, tap the piece of wood sharply with a small hammer to break the blades loose.

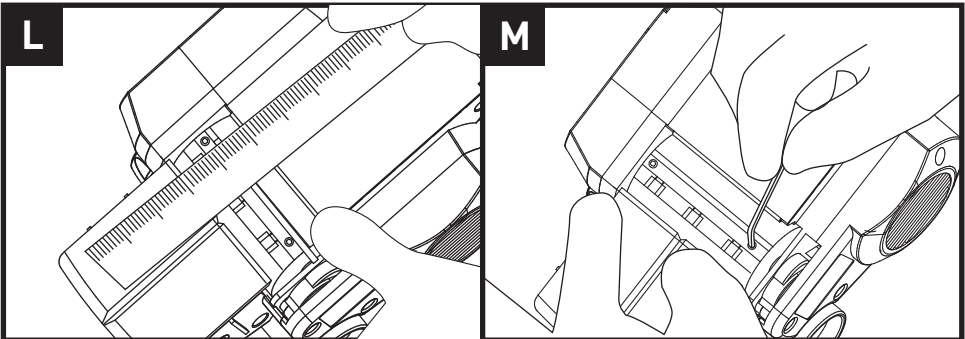
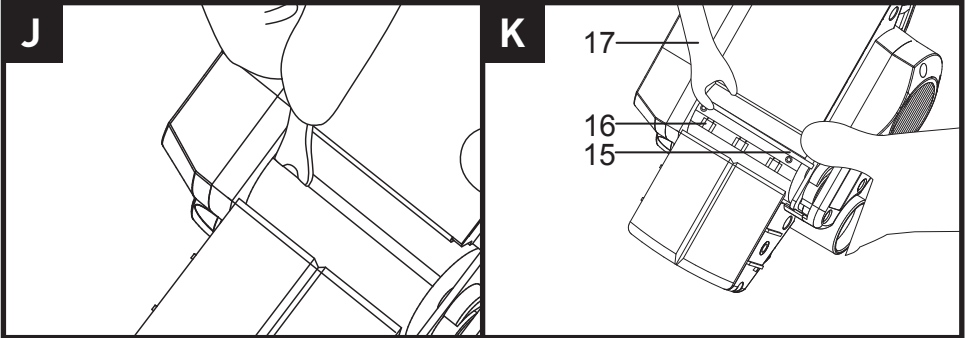

Operating Instructions

Before reinserting a new or reverse blade, always clean both the blade and the blade seat if dirty. Slide the blade into the clamp with a spanner (or a screwdriver) in the correct orientation. Check the blade is equal with the clamp. Retighten the three blade screws with the spanner.

Repeat the above procedure to change the other blade.

After the blades are replaced, check if the blades are parallel and in the same surface as the rear base plate with a ruler. If not, you can adjust the blades with the hexagonal wrench provided. Firstly loosen the three screws on the blade clamp. Turn the socket head screw clockwise, the blade will be risen. Turn it anticlockwise, the blade will be lowered down. Finally retighten the three screws fully.

10. REPLACING A DRIVE BELT (SEE FIG N, O)



1. Remove the plug from the socket before carrying out any adjustment, servicing or maintenance.
2. The cutting blades will be turning and may cause injury.
3. Always put on gloves when operation.

Loosen the screws and remove the belt cover. Remove the worn drive belt from the large pulley and the pinion and clean them. Lace the new belt on the top of the pinion and turn it manually, press it on the large pulley. Make sure that the drive belt runs exactly along the length grooves of the pinion and the pulley. Replace the belt cover. Install the cover screw and tighten fully.

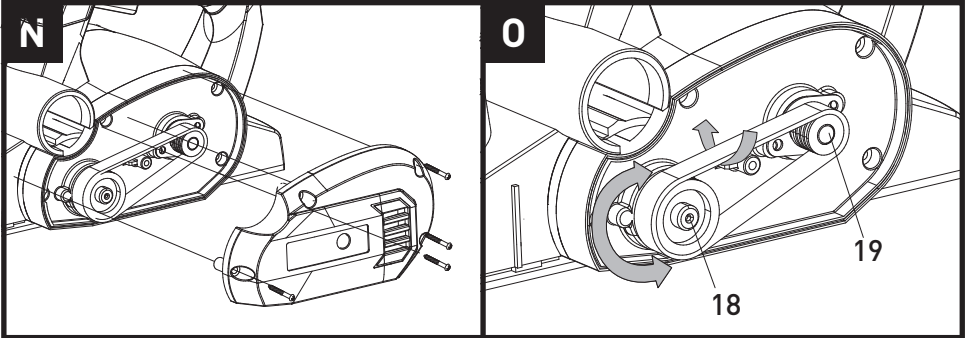

Operating Instructions

11. CORRECT PLANER BLADE SETTING (SEE FIG P)

Your planing surface will end up rough and uneven, unless the blade is set properly and securely.

The blade must be mounted so that the cutting edge is absolutely level, that is, parallel to the surface of the rear base. FIG P shows some examples of proper and improper settings.

(A) Front base (Moveable shoe)

(B) Rear base (Stationary shoe)

1) Correct setting

Although this side view cannot show it, the edges of the blade run perfectly parallel to the rear base surface.

2) Nicks in surface

Cause: one or both blades fails to have edge parallel to rear base line.

3) Gouging at start

Cause: one or both blade edges fails to protrude enough in relation to rear base line.

4) Gouging at end

Cause: one or both blade edges protrude too far in relation to rear base line.

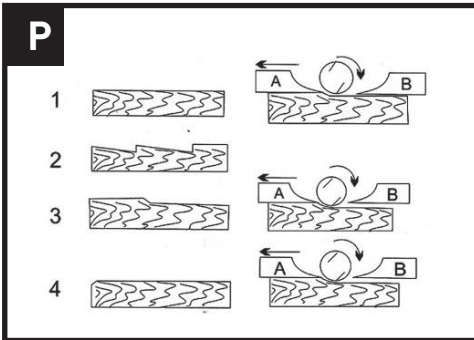

Maintenance

Remove the plug from the socket before carrying out any adjustment, servicing or maintenance.

Your power tool requires no additional lubrication or maintenance. There are no user serviceable parts in your power tool. Never use water or chemical cleaners to clean your power tool. Wipe clean with a dry cloth. Always store your power tool in a dry place. Keep the motor ventilation slots clean. Keep all working controls free of dust. Occasionally you may see sparks through the ventilation slots. This is normal and will not damage your power tool.

If the supply cord is damaged, it must be replaced by the manufacturer, its service agent or similarly qualified persons in order to avoid a hazard.

Technical Data

Technical Data Table

Voltage	220-240V~50Hz
Power input	650W
No load speed	16000/min
Max cutting depth	2mm
Max cutting width	82mm
Max rebate depth	10mm
Protection class	□/II
Machine weight	2.72kg

Noise Information

A weighted sound pressure

A weighted sound power

Wear ear protection.

L_{pA} : 74dB(A)
 L_{wA} : 85dB(A)
 K_{pA} & K_{wA} = 3dB(A)



Technical Data

Vibration Information

Vibration total values (triax vector sum) determined according to EN 60745:
Vibration emission value $a_h = 3.915\text{m/s}^2$
Uncertainty $K = 1.5\text{m/s}^2$

The declared vibration total value may be used for comparing one tool with another, and may also be used in a preliminary assessment of exposure.

 **WARNING:** The vibration emission value during actual use of the power tool can differ from the declared value depending on the ways in which the tool is used dependant on the following examples and other variations on how the tool is used:
The tool being in good condition and well maintained.
The use the correct accessory for the tool and ensuring it is sharp and in good condition.
The tightness of the grip on the handles and if any anti vibration accessories are used.
And the tool is being used as intended by its design and these instructions.

This tool may cause hand-arm vibration syndrome if its use is not adequately managed.

 **WARNING:** To be accurate, an estimation of exposure level in the actual conditions of use should also take account of all parts of the operating cycle such as the times when the tool is switched off and when it is running idle but not actually doing the job. This may significantly reduce the exposure level over the total working period. Helping to minimize your vibration exposure risk.
ALWAYS use sharp chisels, drills and blades.
Maintain this tool in accordance with these instructions and keep well lubricated (where appropriate).
If the tool is to be used regularly then invest in anti vibration accessories.
Avoid using tools in temperatures of 10°C or less.
Plan your work schedule to spread any high vibration tool use across a number of days.

Environmental Protection



Waste electrical products must not be disposed of with household waste. Please recycle where facilities exist. Check with your local authorities or retailer for recycling advice.

Guarantee

This product is selected for DOMESTIC USE ONLY and not for business use. This product is guaranteed against manufacturing defects for a period of 24 months. This does not cover the product where the fault is due to misuse, abuse, use in contravention of the instructions, or where the product has been the subject of unauthorised modifications or alterations, or has been the subject of commercial use. In the event of a problem with the product within the guarantee period please return it to your nearest store. If the item is shown to have an inherent defect present at the time of sale, the store will provide you with a replacement. Your statutory rights remain unaffected.

Issue1 08/2015

Declaration of Conformity

This Guild 650W Planer model number PPL650G fully complies with the Machinery Directive 2006/42/EC, Electromagnetic Compatibility Directive 2004/108/EC(before 2016/04/20) and 2014/30/EC(since 2016/04/20), RoHS Directive 2011/65/EU and the following harmonized EU standards

EN 60745-2-14:2009 /A2:2010

EN 60745-1: 2009 + A11: 2010

EN 55014-1: 2006 + A1:2009 + A2:2011

EN 55014-2: 1997 + A1:2001 + A2:2008

EN 61000-3-2: 2014

EN 61000-3-3: 2013

This declaration is made under the sole responsibility of Argos Ltd, 489/499 Avebury Boulevard, Milton Keynes, MK9 2NW

Category Technical Manager
Issued 20/10/2015

signed *Luke Wong*

Plug Replacement (Uk & Ireland Only)

If you need to replace the fitted plug then follow the instructions below.

IMPORTANT

The wires in the mains lead are colored in accordance with the following code:

Blue – Neutral

Brown – Live

As the colors of the wires in the mains lead of this appliance may not correspond with the coloured markings identifying the terminals in your plug, proceed as follows. The wire which is coloured blue must be connected to the terminal which is marked with N. The wire which is coloured brown must be connected to the terminal which is marked with L.



WARNING:

Never connect live or neutral wires to the earth terminal of the plug. Only fit an approved BS1363/A plug and the correct rated fuse.

Note: If a moulded plug is fitted and has to be removed take great care in disposing of the plug and severed cable, it must be destroyed to prevent engaging into a socket.

