

GUILD

130W 218 Piece Rotary Tool Kit

Instruction Manual

PDM130DC.1

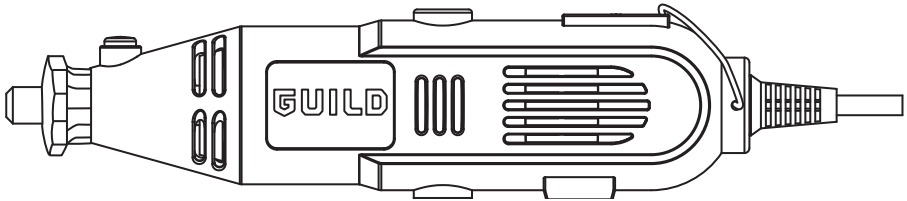

GUILD

After Sales Support

UK/Ireland 0333 3201989
Help@guildpowertools.co.uk

Important - Please read these instructions fully before operating or maintaining your Guild mini drill

These instructions contain important information that will help you get the best from your Guild mini drill, ensuring it remains safe to operate.

If you need help or have damaged or missing parts, call the Customer Helpline on 0333 3201989

Contents

Safety Information.....	3
In The Box.....	10
Accessories.....	10
Operating Instructions.....	12
Using Accessories.....	17
Maintenance.....	18
Trouble Shooting.....	18
Technical Data.....	19
Environmental Protection.....	21
Guarantee.....	21
Declaration of Conformity.....	21
Plug Replacement(UK & Ireland Only).....	22

Safety Information

Important - Please read these instructions fully before starting assembly

Warning Symbols

The following warning symbols appear throughout this assembly manual and indicate the appropriate safety measures you should take when assembling and operating the mini drill.



To reduce the risk of injury, Please read the instruction manual



Warning



Wear ear protection



Wear eye protection



Wear dust mask



Double insulation



Waste electrical products must not be disposed of with household waste. Please recycle where facilities exist. Check with your local authorities or retailer for recycling advice.

Safety Information

Important - Please read these instructions fully before starting assembly

General Power Tool Safety Warnings



WARNING! Read all safety warnings and all instructions. Failure to follow the warnings and instructions may result in electric shock, fire and/or serious injury.

Save all warnings and instructions for future reference.

The term "power tool" in the warnings refers to your mains-operated (corded) power tool or battery-operated (cordless) power tool.

1) Work area safety

- a) **Keep work area clean and well lit.** Cluttered or dark areas invite accidents.
- b) **Do not operate power tools in explosive atmospheres, such as in the presence of flammable liquids, gases or dust.** Power tools create sparks which may ignite the dust or fumes.
- c) **Keep children and bystanders away while operating a power tool.** Distractions can cause you to lose control.

2) Electrical safety

- a) **Power tool plugs must match the outlet. Never modify the plug in any way. Do not use any adapter plugs with earthed (grounded) power tools.** Unmodified plugs and matching outlets will reduce risk of electric shock.
- b) **Avoid body contact with earthed or grounded surfaces, such as pipes, radiators, ranges and refrigerators.** There is an increased risk of electric shock if your body is earthed or grounded.
- c) **Do not expose power tools to rain or wet conditions.** Water entering a power tool will increase the risk of electric shock.
- d) **Do not abuse the cord. Never use the cord for carrying, pulling or unplugging the power tool. Keep cord away from heat, oil, sharp edges or moving parts.** Damaged or entangled cords increase the risk of electric shock.
- e) **When operating a power tool outdoors, use an extension cord suitable for outdoor use.** Use of a cord suitable for outdoor use reduces the risk of electric shock.
- f) **If operating a power tool in a damp location is unavoidable, use a residual current device (RCD) protected supply.** Use of an RCD reduces the risk of electric shock.

3) Personal safety

- a) **Stay alert, watch what you are doing and use common sense when operating a power tool. Do not use a power tool while you are tired or under the influence of drugs, alcohol or medication.** A moment of inattention while operating power tools may result in serious personal injury.
- b) **Use personal protective equipment. Always wear eye protection.** Protective equipment such as dust mask, non-skid safety shoes, hard hat, or hearing protection used for appropriate conditions will reduce personal injuries.
- c) **Prevent unintentional starting. Ensure the switch is in the off-position before connecting to power source and/or battery pack, picking up or carrying the tool.** Carrying power tools with your finger on the switch or energising power tools that have the switch on invites accidents.
- d) **Remove any adjusting key or wrench before turning the power tool on.** A wrench or a

Safety Information

Important - Please read these instructions fully before starting assembly

General Power Tool Safety Warnings

- key left attached to a rotating part of the power tool may result in personal injury.
- e) **Do not overreach. Keep proper footing and balance at all times.** This enables better control of the power tool in unexpected situations.
 - f) **Dress properly. Do not wear loose clothing or jewellery. Keep your hair, clothing and gloves away from moving parts.** Loose clothes, jewellery or long hair can be caught in moving parts.
 - g) **If devices are provided for the connection of dust extraction and collection facilities, ensure these are connected and properly used.** Use of dust collection can reduce dust-related hazards.
- 4) Power tool use and care**
- a) **Do not force the power tool. Use the correct power tool for your application.**
The correct power tool will do the job better and safer at the rate for which it was designed.
 - b) **Do not use the power tool if the switch does not turn it on and off.** Any power tool that cannot be controlled with the switch is dangerous and must be repaired.
 - c) **Disconnect the plug from the power source and/or the battery pack from the power tool before making any adjustments, changing accessories, or storing power tools.** Such preventive safety measures reduce the risk of starting the power tool accidentally.
 - d) **Store idle power tools out of the reach of children and do not allow persons unfamiliar with the power tool or these instructions to operate the power tool.**
Power tools are dangerous in the hands of untrained users.
 - e) **Maintain power tools. Check for misalignment or binding of moving parts, breakage of parts and any other condition that may affect the power tool's operation. If damaged, have the power tool repaired before use.** Many accidents are caused by poorly maintained power tools.
 - f) **Keep cutting tools sharp and clean.** Properly maintained cutting tools with sharp cutting edges are less likely to bind and are easier to control.
 - g) **Use the power tool, accessories and tool bits etc. in accordance with these instructions, taking into account the working conditions and the work to be performed.** Use of the power tool for operations different from those intended could result in a hazardous situation.
- 5) Service**
- a) **Have your power tool serviced by a qualified repair person using only identical replacement parts.** This will ensure that the safety of the power tool is maintained.

Safety Information

Important - Please read these instructions fully before starting assembly

Safety instructions for all operations

Safety Warnings common for grinding, sanding, wire brushing, polishing, carving or abrasive cutting-off operations:

- a) **This power tool is intended to function as a grinder, sander, wire brush, polisher, carving or cut-off tool. Read all safety warnings, instructions, illustrations and specifications provided with this power tool.** Failure to follow all instructions listed below may result in electric shock, fire and/or serious injury.
- b) **Do not use accessories which are not specifically designed and recommended by the tool manufacturer.** Just because the accessory can be attached to your power tool, it does not assure safe operation.
- c) **The rated speed of the grinding accessories must be at least equal to the maximum speed marked on the power tool.** Grinding accessories running faster than their rated speed can break and fly apart.
- d) **The outside diameter and the thickness of your accessory must be within the capacity rating of your power tool.** Incorrectly sized accessories cannot be adequately controlled.
- e) **The arbour size of wheels, sanding drums or any other accessory must properly fit the spindle or collet of the power tool.** Accessories that do not match the mounting hardware of the power tool will run out of balance, vibrate excessively and may cause loss of control.
- f) **Mandrel mounted wheels, sanding drums, cutters or other accessories must be fully inserted into the collet or chuck.** If the mandrel is insufficiently held and/or the overhang of the wheel is too long, the mounted wheel may become loose and be ejected at high velocity.
- g) **Do not use a damaged accessory. Before each use inspect the accessory such as abrasive wheels for chips and cracks, sanding drum for cracks, tear or excess wear, wire brush for loose or cracked wires. If power tool or accessory is dropped, inspect for damage or install an undamaged accessory. After inspecting and installing an accessory, position yourself and bystanders away from the plane of the rotating accessory and run the power tool at maximum no-load speed for one minute.**
Damaged accessories will normally break apart during this test time.
- h) **Wear personal protective equipment. Depending on application, use face shield, safety goggles or safety glasses. As appropriate, wear dust mask, hearing protectors, gloves and workshop apron capable of stopping small abrasive or workpiece fragments.** The eye protection must be capable of stopping flying debris generated by various operations. The dust mask or respirator must be capable of filtering particles generated by your operation. Prolonged exposure to high intensity noise may cause hearing loss.
- i) **Keep bystanders a safe distance away from work area. Anyone entering the work area must wear personal protective equipment.** Fragments of workpiece or of a broken accessory may fly away and cause injury beyond immediate area of operation.
- j) **Hold power tool by insulated gripping surfaces only, when performing an operation where the cutting accessory may contact hidden wiring or its own cord.** Cutting accessory contacting a "live" wire may make exposed metal parts of the power tool "live" and could give the operator an electric shock.
- k) **Always hold the tool firmly in your hand(s) during the start-up.** The reaction torque of the motor, as it accelerates to full speed, can cause the tool to twist.
- l) **Use clamps to support workpiece whenever practical. Never hold a small workpiece**

Safety Information

Important - Please read these instructions fully before starting assembly

Safety Warnings for battery pack

in one hand and the tool in the other hand while in use. Clamping a small workpiece allows you to use your hand(s) to control the tool. Round material such as dowel rods, pipes or tubing have a tendency to roll while being cut, and may cause the bit to bind or jump toward you.

- m) Position the cord clear of the spinning accessory.** If you lose control, the cord may be cut or snagged and your hand or arm may be pulled into the spinning accessory.
- n) Never lay the power tool down until the accessory has come to a complete stop.** The spinning accessory may grab the surface and pull the power tool out of your control.
- o) After changing the bits or making any adjustments, make sure the collet nut, chuck or any other adjustment devices are securely tightened.** Loose adjustment devices can unexpectedly shift, causing loss of control, loose rotating components will be violently thrown.
- p) Do not run the power tool while carrying it at your side.** Accidental contact with the spinning accessory could snag your clothing, pulling the accessory into your body.
- q) Regularly clean the power tool's air vents.** The motor's fan will draw the dust inside the housing and excessive accumulation of powdered metal may cause electrical hazards.
- r) Do not operate the power tool near flammable materials.** Sparks could ignite these materials.
- s) Do not use accessories that require liquid coolants.** Using water or other liquid coolants may result in electrocution or shock.

Further safety instructions for all operations

Kickback and related warnings

Kickback is a sudden reaction to a pinched or snagged rotating wheel, sanding band, brush or any other accessory. Pinching or snagging causes rapid stalling of the rotating accessory which in turn causes the uncontrolled power tool to be forced in the direction opposite of the accessory's rotation.

For example, if an abrasive wheel is snagged or pinched by the workpiece, the edge of the wheel that is entering into the pinch point can dig into the surface of the material causing the wheel to climb out or kick out. The wheel may either jump toward or away from the operator, depending on direction of the wheel's movement at the point of pinching. Abrasive wheels may also break under these conditions.

Kickback is the result of power tool misuse and/or incorrect operating procedures or conditions and can be avoided by taking proper precautions as given below.

- a) Maintain a firm grip on the power tool and position your body and arm to allow you to resist kickback forces.** The operator can control kickback forces, if proper precautions are taken.
- b) Use special care when working corners, sharp edges etc. Avoid bouncing and snagging the accessory.** Corners, sharp edges or bouncing have a tendency to snag the rotating accessory and cause loss of control or kickback.
- c) Do not attach a toothed saw blade.** Such blades create frequent kickback and loss of control.
- d) Always feed the bit into the material in the same direction as the cutting edge is exiting from the material (which is the same direction as the chips are thrown).**

Safety Information

Important - Please read these instructions fully before starting assembly

Further safety instructions for all operations

Feeding the tool in the wrong direction causes the cutting edge of the bit to climb out of the work and pull the tool in the direction of this feed.

- e) **When using rotary files, cut-off wheels, high-speed cutters or tungsten carbide cutters, always have the work securely clamped.** These wheels will grab if they become slightly canted in the groove, and can kickback. When a cut-off wheel grabs, the wheel itself usually breaks. When a rotary file, high-speed cutter or tungsten carbide cutter grabs, it may jump from the groove and you could lose control of the tool.

Safety Warnings Specific for Grinding and Abrasive Cutting-Off Operations:

- a) **Use only wheel types that are recommended for your power tool and only for recommended applications. For example: do not grind with the side of a cut-off wheel.** Abrasive cut-off wheels are intended for peripheral grinding, side forces applied to these wheels may cause them to shatter.
- b) **For threaded abrasive cones and plugs use only undamaged wheel mandrels with an unrelieved shoulder flange that are of correct size and length.** Proper mandrels will reduce the possibility of breakage.
- c) **Do not “jam” a cut-off wheel or apply excessive pressure. Do not attempt to make an excessive depth of cut.** Overstressing the wheel increases the loading and susceptibility to twisting or snagging of the wheel in the cut and the possibility of kickback or wheel breakage.
- d) **Do not position your hand in line with and behind the rotating wheel.** When the wheel, at the point of operation, is moving away from your hand, the possible kickback may propel the spinning wheel and the power tool directly at you.
- e) **When wheel is pinched, snagged or when interrupting a cut for any reason, switch off the power tool and hold the power tool motionless until the wheel comes to a complete stop. Never attempt to remove the cut-off wheel from the cut while the wheel is in motion otherwise kickback may occur.** Investigate and take corrective action to eliminate the cause of wheel pinching or snagging.
- f) **Do not restart the cutting operation in the workpiece. Let the wheel reach full speed and carefully re-enter the cut.** The wheel may bind, walk up or kickback if the power tool is restarted in the workpiece.
- g) **Support panels or any oversized workpiece to minimize the risk of wheel pinching and kickback.** Large workpieces tend to sag under their own weight. Supports must be placed under the workpiece near the line of cut and near the edge of the workpiece on both sides of the wheel.
- h) **Use extra caution when making a “pocket cut” into existing walls or other blind areas.** The protruding wheel may cut gas or water pipes, electrical wiring or objects that can cause kickback.

Safety Information

Important - Please read these instructions fully before starting assembly

Safety Warnings Specific for Wire Brushing Operations

- a) **Be aware that wire bristles are thrown by the brush even during ordinary operation. Do not overstress the wires by applying excessive load to the brush.** The wire bristles can easily penetrate light clothing and/or skin.
- b) **Allow brushes to run at operating speed for at least one minute before using them. During this time no one is to stand in front or in line with the brush.** Loose bristles or wires will be discharged during the run-in time.
- c) **Direct the discharge of the spinning wire brush away from you.** Small particles and tiny wire fragments may be discharged at high velocity during the use of these brushes and may become imbedded in your skin.

In The Box

Parts

- | | |
|---------------------------------------|------------------|
| 1 Collet Nut | 4 Speed selector |
| 2 Spindle Lock Button | 5 Hook |
| 3 Carbon Brush Holder (on both sides) | 6 On/Off switch |

Accessories

- | | |
|---|----|
| 7 Collet (Ø1.6 mm x 1, Ø2.3 mm x 2, Ø3.2 mm x 3)
(one in the tool, one in flexible shaft(28), four in the box) | 6 |
| 8 Polishing compound | 1 |
| 9 Cut-off wheel (15/16" x 1/40" & 15/16" x 1/32") | 65 |
| 10 Sanding disk (180/320 grit) | 72 |
| 11 Cutting wheel fixture (shank size: Ø3.2 mm) | 3 |
| 12 Grinding disc | 12 |
| 13 Fiberboard cutting disc | 5 |
| 14 Grinding bits (shank size: Ø3.2 mm) | 10 |
| 15 Rubber sanding roll (shank size: Ø3.2 mm) | 2 |
| 16 Sanding drum | 12 |
| 17 Brush (shank size: Ø3.2 mm) | 7 |
| 18 Flap wheel (shank size: Ø3.2 mm) | 1 |
| 19 Cloth wheel | 1 |
| 20 HSS twist drills (shank size: 2 x Ø1.6, 2 x Ø2.3, 2 x Ø3.2) | 6 |
| 21 HSS cutter (shank size: Ø3.2 mm) | 2 |
| 22 Felt wheels | 6 |
| 23 Rubber wheel | 1 |
| 24 Screw drill (shank size: Ø3.2 mm) | 1 |
| 25 Diamond grinding bits (shank size: Ø3.2 mm) | 5 |
| 26 Grinding stone | 1 |
| 27 Collet spanner | 1 |
| 28 Flexible shaft | 1 |
| 29 Locking pin | 1 |

In The Box

Parts

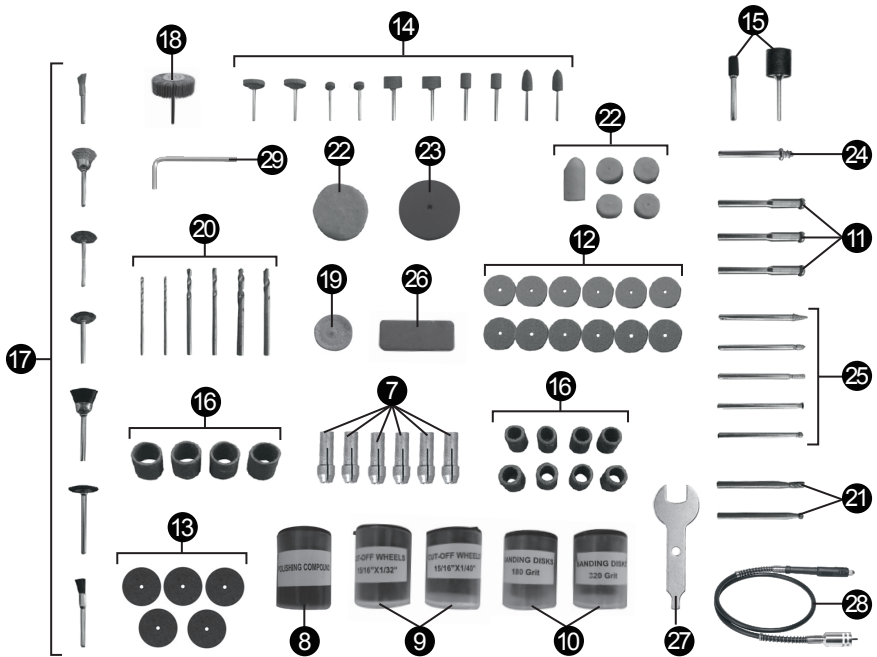
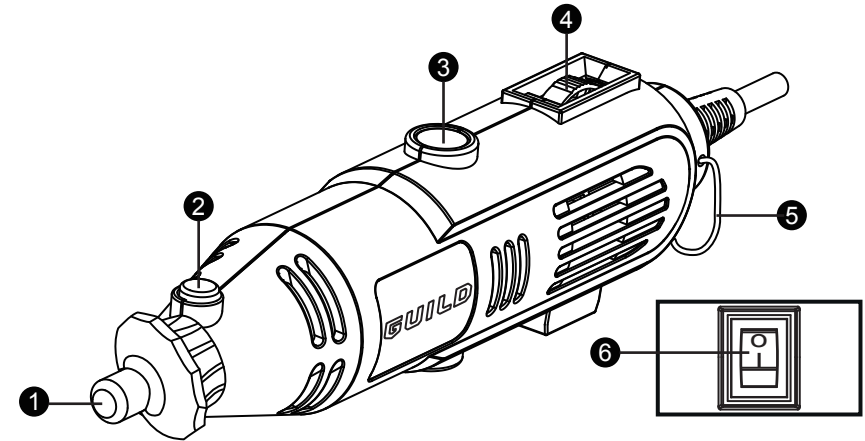

Operating Instructions



NOTE: Before using the tool, read the instruction book carefully.

Intended Use

This tool is intended for grinding, polishing metal as well as for cutting metal and drilling in metal and wood.

1. CHANGE THE COLLET (SEE FIG A)

Three size of collets are provided to accommodate the different accessories shank sizes. When using an accessory with a smaller or larger shaft, you will need to change the collet which matches the shank size of the accessory as follows.

Press the spindle lock button. Loosen the collet nut (1) with the spanner provided. Remove the collet nut (1) and then fully insert the appropriate size collet (7) into the spindle. Reinstall the collet nut (1) by finger tight. Do not over-tighten the nut when there is no accessory in the collet.



WARNING! Fully tighten the collet nut before operation.

Always use the collet which matches the shank size of the accessory you plan to use. Do not force a larger diameter shank into a smaller collet.

2. FITTING AN ACCESSORY (SEE FIG B, C)

Press the spindle lock button. Hold down and rotate the spindle by hand until the spindle lock engages with the spindle. Loosen the collet nut anti-clockwise using the spanner if necessary.

Fully insert the tool shank into the collet. Tighten the collet nut with the spanner but do not over-tighten. Finally release the spindle lock button.



WARNING: Do not engage the spindle lock button while the tool is running.

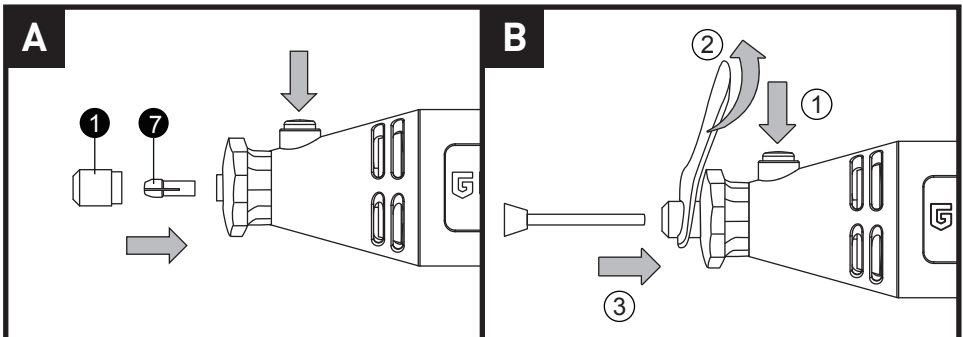

Operating Instructions

3. FITTING A CUTTING/SANDING WHEEL (SEE FIG D, E)

First fit the cutting wheel fixture (11) into the collet. Loosen the small screw (a) on the cutting wheel fixture (11) with top of collet spanner (27). Insert the screw through the cutting wheel and then screw into the cutting wheel fixture (11). Do not over-tighten otherwise the wheel may crack.

4. ASSEMBLING THE FELT WHEEL (SEE FIG F)

The felt wheel (22) is used with the screw drill (24). Thread the wheel on to the screw carefully. The wool wheel must thread down straight on the screw drill, and be turned all the way to the collar.

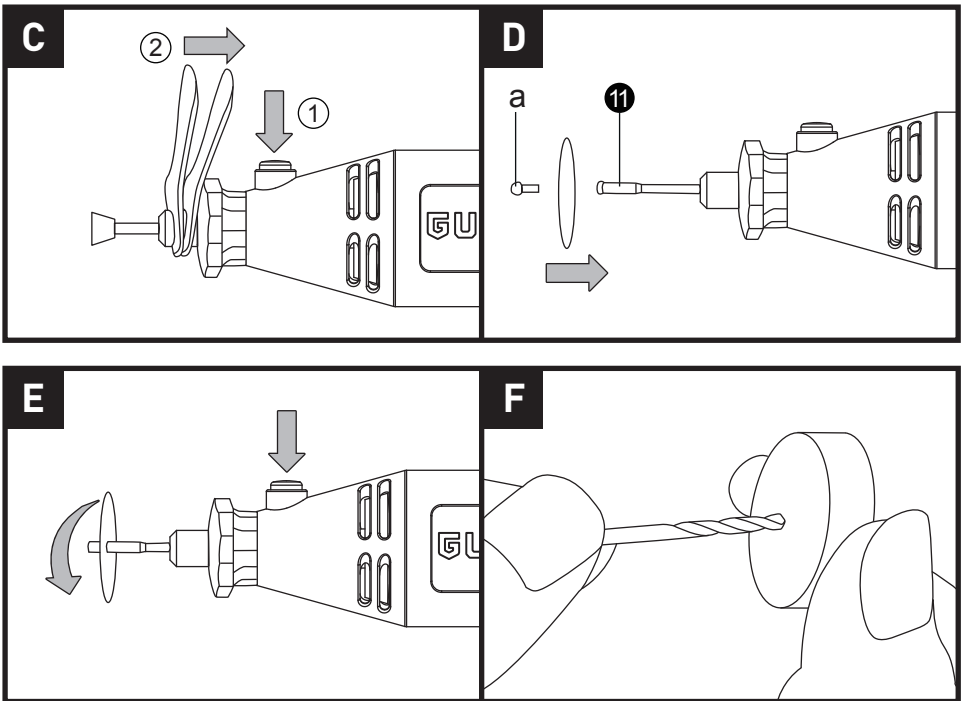

Operating Instructions

5. FITTING THE SANDING ROLL (SEE FIG G1, G2, G3)

To fit the sanding roll, firstly loosen the small screw on top of the hole for rubber wheel, this will allow the rubber to relax. Slide the sanding roll onto the holder.

To secure, simply tighten the screw and the rubber roll will swell, gripping the sanding drum.

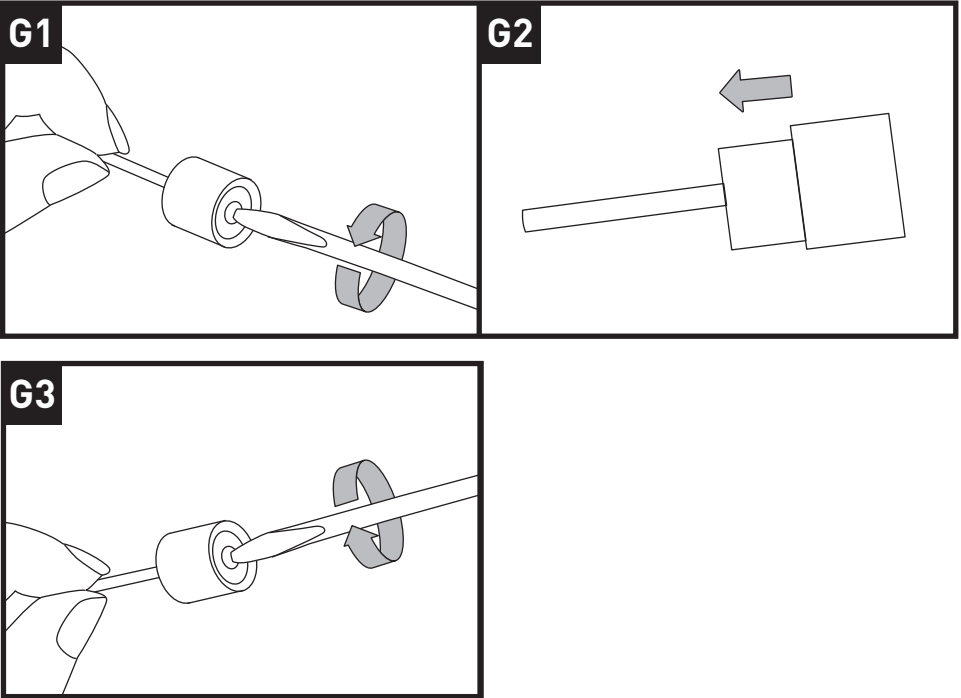

Operating Instructions

6. CONNECT THE FLEXIBLE SHAFT TO THE TOOL (SEE FIG H)

WARNING! Never bend the flexible shaft with a radius of less than 152mm when operating. Always store the flexible shaft carefully to avoid sharp bends when not in use.

- 1). Depress spindle lock button (2) and unscrew counter-clockwise the collet nut (1) and plastic ring (a) from the spindle.
- 2). Remove the collet from the spindle socket (b).
- 3). Insert the inner shaft (c) of flexible shaft into the spindle socket (b) until the bump (d) touches the spindle socket.
- 4). Screw clockwise the fixed ring (e) of flexible shaft onto housing thread.
- 5). Tighten the fixed ring (e) by hand. Do not use pliers or spanner.

7. REPLACE THE COLLET & ACCESSORIES ONTO FLEXIBLE SHAFT (SEE FIG I)

- 1). Rotate the collet of flexible shaft until the hole on the shaft is aligned with the hole (f) of the flexible shaft collar, insert the locking pin (29) to lock the inner shaft (c) and then unscrew counter-clockwise the collet nut by supplied spanner (27).
- 2). Fit accessory to spindle socket of flexible shaft through appropriate size collet (7). Keep locking pin to lock the inner shaft (c), tighten clockwise the collet nut by spanner.

WARNING! Fully tighten the collet nut before operation. Always use the collet which matches the shank size of the accessory you plan to use. Do not force a small diameter shank into a large collet.

WARNING! Do not attempt to loosen or tighten the collet without locking the shaft as noted above. Damage to the flexible shaft will result.

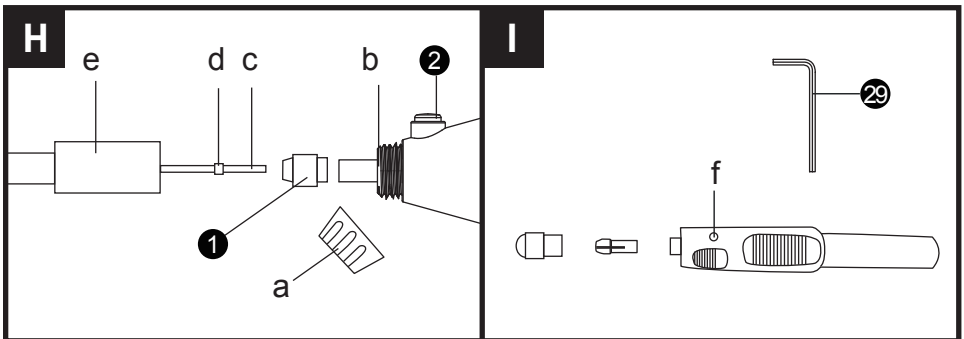

Operating Instructions

OPERATION

1. SWITCH ON / OFF (SEE FIG J)

NOTE: This tool has been set to the slowest speed before switching on.

To start the tool, press the on/off switch to "I" ON position. To stop, press the switch to "O" OFF position.

2. SPEED ADJUSTMENT (SEE FIG K)

To achieve the best result when working with different materials, you can adjust the tool speed. It is adjustable from 10000 to 32000/min.

The tool has a variable speed control for precise speed adjustment. Set it to the required speed for operation.

NOTE: Select a low speed when working with wood, plastics and polishing.

Generally, select higher speed for small tools while lower speed for larger tools.

From number "1" to "MAX", the speed is corresponding from 10000 to 32000/min.

3. DRILLING OPERATION

Turn the tool on until full speed. Apply the tool to the workpiece gently. To obtain a good finish, move the tool in the leftward direction slowly.

NOTE: Apply light pressure on the tool. Excessive pressure will only cause a poor finish and overloading of the motor.

4. HOLDING THE TOOL

For milling or engraving, hold the tool like a pen. Take care not to cover the ventilation slots.

NOTE: The tool will get warm during normal operation. Observe the rated operating time.

5. USING THE DRILLS

The HSS twist drills (20) are used to cut through all types of steels and steel composites.

6. POLISHING WITH THE FELT WHEEL



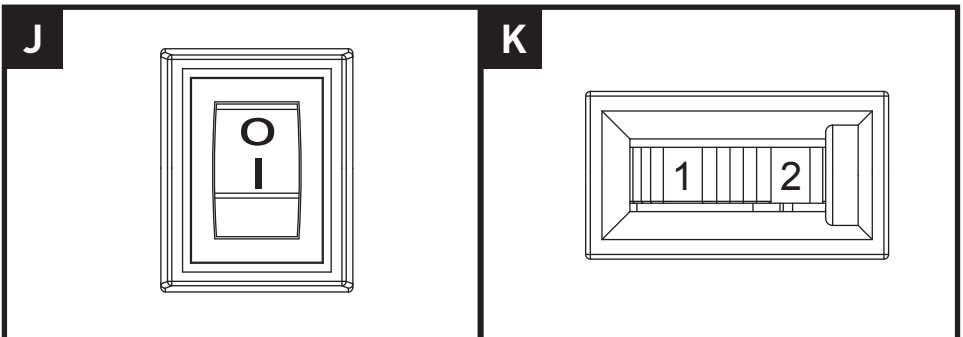

After assembling the felt wheel to the screw drill (SEE FIG H & I), it can be used to polish plastics, metals, steels, jewelry and small parts with polishing compound, which will give a high luster to the surfaces of the materials. For best results, polishing accessories should be used at speeds not greater than half speed.

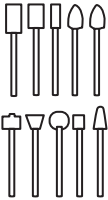

Using Accessories

The chart below lists the description, use speed and scope for some of the small articles supplied together with the tool by category. To achieve best performance of the tool, it is strongly recommended that you read it prior to operation, failure to adhere to this may cause accessories to fail.

NOTE: ALWAYS Wear eye protection Insert the shaft FULLY into the collet. Use ONLY up to the speeds stated below.

PICTURE	DESCRIPTION	SPEED	FOR USE ON
	Grinder bits Various head styles, on shafts	Full speed 32,000/min	Metal Mild steel
	Diamond Bits Various head styles	Full speed 32,000/min	Wood Zinc Plastic Nickel Copper Mild steel
	Wool Wheel Mounted to screw drill	Half speed 16,000/min	Metal Mild steel
	Sanding/Cutting wheels Mounted to cutting wheel fixture NOTE: DO NOT over tighten screw	Half speed 16,000/min	Metal Mild steel Wood
	Sanding Roll Mounted on hold for rubber wheel	Full speed 32,000/min	Metal Mild steel

Maintenance & Trouble Shooting



WARNING: Remove the plug from the socket before carrying out any adjustment, servicing or maintenance.

REPLACING THE CARBON BRUSHES (SEE FIG L, M, N)

The carbon brushes must be checked on a regular basis. There are two brushes in the tool and they must be replaced in pairs.

Remove the carbon brush holders with the spanner and check the brushes. If the length of brush is less than 6mm, replace both brushes. Have the tool run at no load for 15 minutes.

NOTE: Use only the correct type of carbon brushes.

CAUTION: Using the tool with worn brushes (available from Guild helpline) will permanently damage the motor.

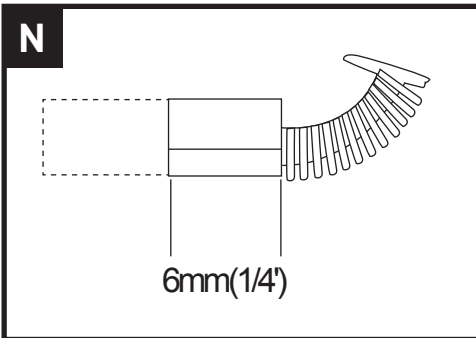
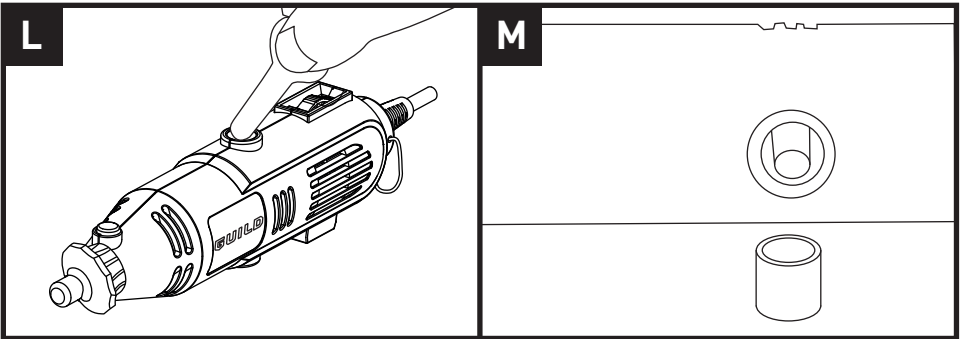

Maintenance

There are no user serviceable parts in your power tool. Never use water or chemical cleaners to clean your power tool. Wipe clean with a dry cloth. Always store your power tool in a dry place. Keep the motor ventilation slots clean. Keep all working controls free of dust. Occasionally you may see sparks through the ventilation slots. This is normal and will not damage your power tool.

If the supply cord is damaged, it must be replaced by the manufacturer, its service agent or similarly qualified persons in order to avoid a hazard.

Trouble Shooting

1. If your power tool does not start, check the plug on the mains supply first.
2. If your power tool use in low efficiency, check the tool speed and type of accessory.
3. If a fault can not be rectified, return the tool to an authorized dealer for repair.

Technical Data

Technical Data Table

Rated voltage	230-240V-50Hz
Rated power	130W
Collet size	Ø1.6 / Ø2.3 / Ø3.2mm
Rated no load speed	10000-32000/min
Protection class	□/II
Weight	0.68kg

Noise Information

A weighted sound pressure
A weighted sound power

Wear ear protection.

L_{pA} : 71dB(A)
 L_{wA} : 82dB(A)
 K_{pA} & K_{wA} = 3.0dB(A)



Technical Data

Vibration Information

Vibration total values (triax vector sum) determined according to EN 60745:	
Typical weighted vibration	Vibration emission value: $a_h = 1.13\text{m/s}^2$
	Uncertainty $K = 1.5\text{m/s}^2$

The declared vibration total value may be used for comparing one tool with another, and may also be used in a preliminary assessment of exposure.



WARNING: The vibration emission value during actual use of the power tool can differ from the declared value depending on the ways in which the tool is used dependant on the following examples and other variations on how the tool is used:

How the tool is used and the materials being cut or drilled.

The tool being in good condition and well maintained

The use the correct accessory for the tool and ensuring it is sharp and in good condition.

The tightness of the grip on the handles and if any anti vibration accessories are used.

And the tool is being used as intended by its design and these instructions.

This tool may cause hand-arm vibration syndrome if its use is not adequately managed.



WARNING: To be accurate, an estimation of exposure level in the actual conditions of use should also take account of all parts of the operating cycle such as the times when the tool is switched off and when it is running idle but not actually doing the job. This may significantly reduce the exposure level over the total working period.

Helping to minimize your vibration exposure risk.

ALWAYS use sharp chisels, drills and blades.

Maintain this tool in accordance with these instructions and keep well lubricated (where appropriate).

If the tool is to be used regularly then invest in anti vibration accessories.

Avoid using tools in temperatures of 10°C or less.

Plan your work schedule to spread any high vibration tool use across a number of days.

Environmental Protection



Waste electrical products should not be disposed of with household waste. Please recycle where facilities exist. Check with your Local Authority or retailer for recycling advice.

Guarantee

This product is selected for DOMESTIC USE ONLY and not for business use.

This product is guaranteed against manufacturing defects for a period of 24 months. This does not cover the product where the fault is due to misuse, abuse, use in contravention of the instructions, or where the product has been the subject of unauthorised modifications or alterations, or has been the subject of commercial use. In the event of a problem with the product within the guarantee period please return it to your nearest store. If the item is shown to have an inherent defect present at the time of sale, the store will provide you with a replacement. Your statutory rights remain unaffected.

Issue1 08/2015

Declaration of Conformity

This Guild 130W 218 Piece Rotary Tool Kit model number PDM130DC.1 fully complies with the Machinery Directive 2006/42/EC, Electromagnetic Compatibility Directive 2004/108/EC(before 2016/04/20) and 2014/30/EC(since 2016/04/20), RoHS Directive 2011/65/EU and the following harmonized EU standards

EN 60745-2-23:2013

EN 55014-1: 2006 + A1:2009 + A2:2011

EN 55014-2: 1997 + A1:2001 + A2:2008

EN 61000-3-2: 2014

EN 61000-3-3: 2013

This declaration is made under the sole responsibility of Argos Ltd, 489/499 Avebury Boulevard, Milton Keynes, MK9 2NW

Category Technical Manager

Issued 20/10/2015

signed *Lane Wong*

Plug Replacement (Uk & Ireland Only)

If you need to replace the fitted plug then follow the instructions below.

IMPORTANT

The wires in the mains lead are colored in accordance with the following code:

Blue – Neutral

Brown – Live

As the colors of the wires in the mains lead of this appliance may not correspond with the coloured markings identifying the terminals in your plug, proceed as follows. The wire which is coloured blue must be connected to the terminal which is marked with N. The wire which is coloured brown must be connected to the terminal which is marked with L.



WARNING:

Never connect live or neutral wires to the earth terminal of the plug. Only fit an approved BS1363/A plug and the correct rated fuse.

Note: If a moulded plug is fitted and has to be removed take great care in disposing of the plug and severed cable, it must be destroyed to prevent engaging into a socket.

