

Series 4, Built-in freezer, 82 x 59.8 cm, flat hinge GUN21VFE0G



Built-under freezer with No Frost and Door Alarm for convenient and worry-free freezing where space is limited.

- **NoFrost:** never defrost again, thanks to perfect protection from ice formation - that saves time and effort.
- **Connectivity:** Remotely monitor and control your fridge from your smartphone or tablet.
- **Automatic Super Freezing function:** optimal for freezing smaller food load faster whilst protecting your frozen items from defrosting, thanks to the detection of temperature increase and the automatic decrease of temperature
- **HolidayMode:** protecting frozen foods and preventing energy wastage in the fridge.
- **Fresh Sense:** always reliable temperature control.

Technical Data

Energy Efficiency Class: E
 Average annual energy consumption in kilowatt hour per year (kWh/a): 189 kWh/annum
 Sum of volume of frozen compartments: 85 l
 Airborne acoustical noise emissions : 35 dB(A) re 1 pW
 Airborne acoustical noise emission class: B
 Light: No
 Product category: Upright freezer
 Installation type: Built-in
 Frost free system: Fridge and freezer
 Height of the appliance: 820 mm
 Width of the appliance: 598 mm
 Depth of the product: 548 mm
 Dimensions of the packed product (HxWxD): 890 x 640 x 640 mm
 Net weight: 30.5 kg
 Gross weight: 33.3 kg
 Fuse protection: 10 A
 Frequency: 50 Hz
 Length of electrical supply cord: 230.0 cm
 Door hinge: Right reversible
 Warning signal / malfunction: Visual
 Door lock: No
 Number of drawers/baskets (Stck): 3
 Number of freezing flaps (Stck): 0
 EAN code: 4242005381104
 Brand: Bosch
 Product name / Commercial code: GUN21VFE0G
 Product category: Upright freezer
 Included accessories: 1 x ice cube tray

Included accessories

1 x ice cube tray

Optional accessories

KFZ10AX0 Door panel with decor frame
 KUZ20SX0 Attachment door, stainless steel



Series 4, Built-in freezer, 82 x 59.8 cm, flat hinge GUN21VFE0G

Built-under freezer with No Frost and Door Alarm for convenient and worry-free freezing where space is limited.

Performance and Consumption

- EU19_EEK_D: E
- Total Volume : 85 l
- Annual Energy Consumption: 189 kWh/a
- Climate Class: SN-T
- Noise Level : 35 dB , EU19_Noise emission class_D: B

Functions

Design features

- NO_FROST_NEU_BL, never have to defrost ever again
- LED electronic control
- Sabbath-Mode
- Freezer malfunction warning signal: optical and accoustical
- SuperFreeze function with automatic deactivation
- Home Connect: iService Remote, Remote Monitoring and Control
- Easy clean interior

Food freshness system

- Net Freezer Volume : 85 l
- 3 freezer drawers
- Temperature rise time : EU19_Temperature rise time_D: 9 H
- EU19_Fast freezer facility_D
- Freezing capacity 24h : 8 kg
- Ice box

Key features - Fridge section

- Right hinged door, door reversible
- can be built under
- Ventilation through plinth
- Length of power cord:230 cm
- 220 - 240 V

Dimension and installation

- Niche Dimensions: 82 cm H x 60 cm W x 55 cm D
- Dimensions: 82 cm H x 59.8 cm W x 54.8 cm D

Key features - Freezer section

- GUN21VFE0G

Country Specific Options

- Based on the results of the standard 24-hour test. Actual consumption depends on usage/position of the appliance.

Additional features

**Series 4, Built-in freezer, 82 x 59.8 cm, flat hinge
GUN21VFE0G**

measurements in mm
Recommended gap dimensions for flat hinges

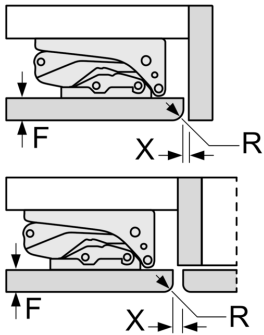

F	R	X
16-19	0-3	2.5
20	0-1	3
	2-3	2.5
21	0-1	3
	2-3	2.5
22	0	4
	1	3.5
	2-3	3

The gap dimensions recommended in the table must be adhered to in order to ensure that appliance doors do not collide with anything when they are opened, and to avoid causing damage to kitchen units.

Measurements in mm

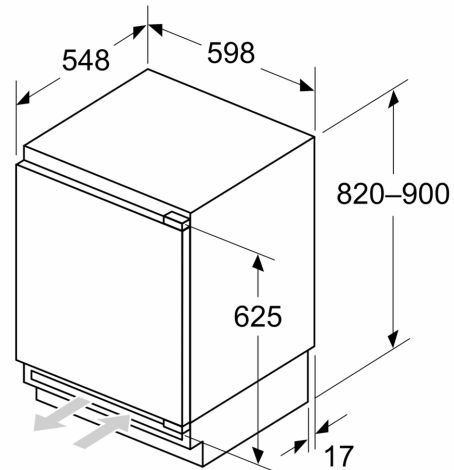

Measurements in mm

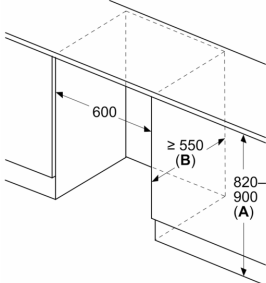

A: Substructure height

B: ≥ 560 mm (recommended)

Space for electrical connection next to the appliance on the left or right side

Measurements in mm

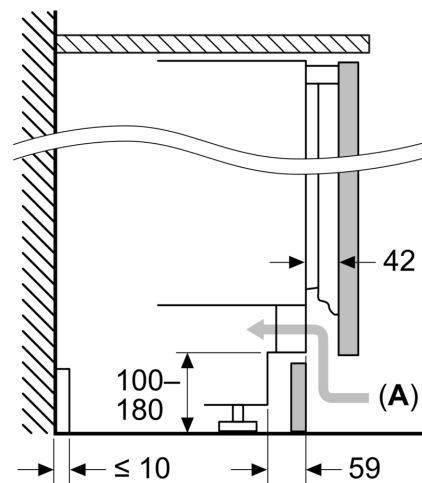

A: Air inlet ≥ 200 cm²

Maximal permissible weight of the unit fronts

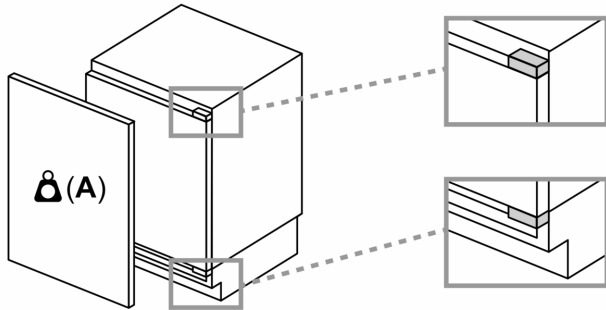

Fitted unit fronts that exceed the permissible weight may cause damage and result in functional impairment of the hinges

A: Weight \leq 12 kg