

N 70, Built-in oven, 60 x 60 cm, Stainless steel
B54CR31NOB



Built-in oven with Slide & Hide® - an easy to handle door that gently disappears under the oven. Home Connect - control your oven via the App.

- ✓ 3,7" Full Touch TFT Display - Intuitive navigation for easy use and complete control.
- ✓ Slide & Hide® - An easy to handle door that disappears under the oven for unrestricted access.
- ✓ Circo Therm® - smart hot-air solution that lets you bake on up to three levels at once.
- ✓ Eco Clean with Easy Clean - the duo that makes oven cleaning easier.
- ✓ Soft Open - oven door with damping system.

Features

Technical Data

Gross weight : 37.3 kg
 Built-in / Free-standing : Built-in
 Integrated Cleaning system : CGV_R65_BO, Hydrolytic
 Min. required niche size for installation (HxWxD) : 585-595 x 560-568 x 550 mm
 Dimensions : 595x596x548 mm
 Dimensions of the packed product (HxWxD) : 670 x 660 x 690 mm
 Control Panel Material : Glass
 Door Material : Glass
 Net weight : 34.7 kg
 Usable volume of cavity : 71 l
 Number of interior lights : 1
 Length electrical supply cord : 120.0 cm
 Interior Lights - cavity 1 : 1
 Pull-out system : Accessory
 Included accessories : 2 x combination grid, 1 x universal pan
 Broil Element Wattages cavity 1 : 2800 W
 Convection Element Wattages cavity 1 : 2300 W
 Energy efficiency class (2010/30/EC) : A+
 Energy consumption per cycle conventional (2010/30/EC) : 0.87 kWh/cycle
 Energy consumption per cycle forced air convection (2010/30/EC) : 0.69 kWh/cycle
 Energy efficiency index (2010/30/EC) : 81.2 %
 Connection Rating : 3600 W
 Fuse protection : 16 A
 Voltage : 220-240 V
 Frequency : 50; 60 Hz
 Plug type : No plug (electrical connection by electrician)
 Energy input : Electric
 Required cutout/niche size for installation (in) : x
 Dimensions of the packed product : 26.37 x 25.98 x 27.16
 Net weight : 76.000 lbs
 Gross weight : 82.000 lbs
 Length electrical supply cord : 120.0 cm
 Net weight : 34.7 kg

Included accessories

2 x combination grid, 1 x universal pan

Optional accessories

Z11AB15A0 : Baking tray, non-stick ceramic coated ,
 Z11AU15A0 : Universal pan, non-stick ceramic coated ,
 Z11CR10X0 : Baking and roasting grid (standard) , Z11GU20X0 :
 Glasspan , Z11SZ00X0 : SeamlessCombination mounting kit ,
 Z11SZ80X1 : SeamlessCombination 60 + 29cm , Z11SZ90X0 :
 SeamlessCombination 60 + 45cm , Z11TI15X0 : Cliprails ,
 Z12CB10A0 : Baking tray, enamelled , Z12CL10A0 : Lid for
 professional pan, enamelled , Z12CM10A0 : Moussaka pan,
 enamelled , Z12CN10A0 : Professional pan, enamelled , Z12CP10A0 :
 Pizza pan, enamelled , Z12CU10A0 : Multipurpose pan, enamelled ,
 Z1365WX0 : Wireless food thermometer , Z13CR10X0 : Baking and
 roasting grid (steam) , Z13CV06S0 : Decor strip , Z1608BX0 : Full ext
 rails, level independent , Z1650BE0 : Half tray , Z1655CA0 : Air Fry &
 Grill tray , Z1913X0 : Baking Stone



Features

Type of oven / heating system:

- Oven with 14 heating methods: CircoTherm®, Conventional heat, Hot air grilling, Full surface grill, Half width grill, Pizza setting, Bread Baking, Bottom heat, Low temperature cooking, Dough proving, Plate warming, Keep warm, CircoTherm® gentle, Conventional heat gentle
- Heating methods only via Home Connect App: Air Fry, let rest, preheating
- Temperature range 40 °C - 275 °C
- Cavity volume: 71 l

Hook-in racks / rails

- Number of shelf levels: 4 PC
- Telescopic shelf rails as optional accessory

Design:

- Touch control
- Cavity inner surface: enamel

Cleaning:

- Eco Clean: coating of back panel
- Easy Clean (program)
- Full glass inner door - safer touch door

Comfort:

- Oven Assistant with Voice Control
- 3,7" Full Touch TFT Display
- Electronic clock
- Temperature proposal
Actual temperature display Optical temperature control
- Hide®, the fully retracting oven door
- Slide®, the revolving handle
- Soft Open
- Supporting systems: Automatic Meal Settings
- Rapid heat
- LED light, Independent oven interior light button
- Cooling fan
- Home Connect ready on Wi-Fi

Accessory:

- 2 x combination grid, 1 x universal pan

Environment and Safety:

- Low door temperature
- Triple glazed door glazed CoolTouch door
- Individual adjustable child lock
Residual heat indicator Start-/Stop button Door contact switch

Technical Information

- Length of mains cable: 120 cm
- Nominal voltage: 220 - 240 V
- Total connected load electric: 3.6 KW
- Energy efficiency rating (acc. EU Nr. 65/2014): A+ (at a range of energy efficiency classes from A+++ to D)
Energy consumption per cycle in conventional mode: 0.87 kWh
Energy consumption per cycle in fan-forced convection mode: 0.69 kWh
Number of cavities: 1 Heat source: electrical Cavity volume: 71 l

Dimensions:

- Appliance dimension (HxWxD): 595 mm x 596 mm x 548 mm
- Niche dimension (HxWxD): 585 mm - 595 mm x 560 mm - 568 mm x 550 mm
- "Please reference the built-in dimensions provided in the installation drawing"

N 70, Built-in oven, 60 x 60 cm, Stainless steel
B54CR31NOB

Dimensioned drawings

Installing two appliances on top of each other
Air exchange

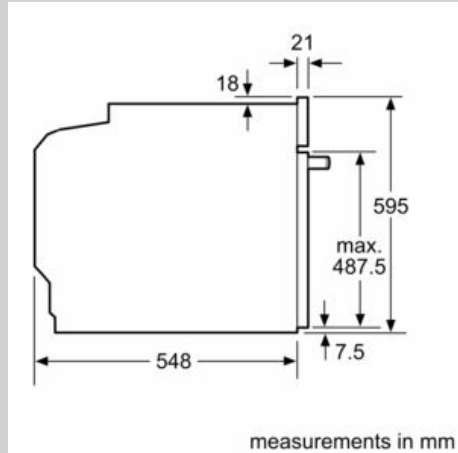
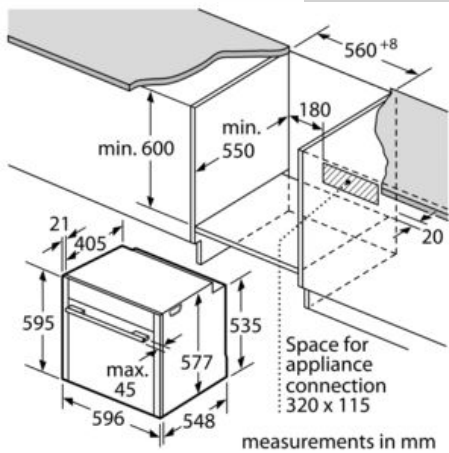
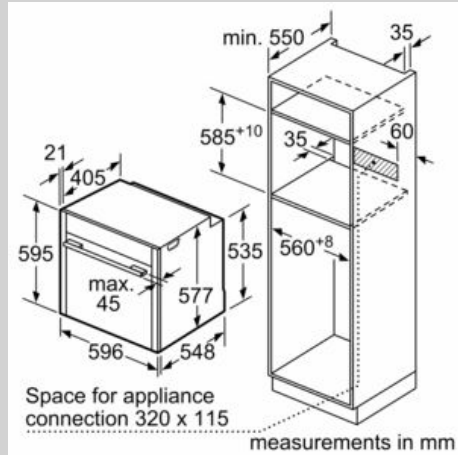
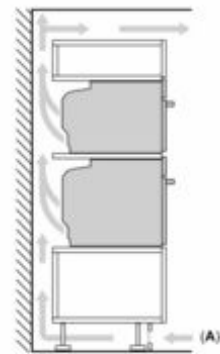

If the appliance will be installed underneath a hob, the following worktop thicknesses (including substructure if necessary) must be taken into account.

Hob type	min. worktop thickness	
	fitted	flush
Induction hob	37 mm	38 mm
Full surface Induction hob	47 mm	48 mm
Gas hob	30 mm	38 mm
Electric hob	27 mm	30 mm