



## **Series 4, Built-in oven with added steam function, 60 x 60 cm, Black HQA534BB3B**

### **Perfect results: Hotair Steam for delicious baking results.**

#### **Type of oven / heating system:**

- Oven with 8 heating methods: 3D Hotair, Conventional heat, Hot air grilling, Full width grill, Pizza setting, Bottom heat, Hotair gentle, Hotair steam
- Temperature range 50 °C - 275 °C
- Cavity volume: 71 l

#### **Hook-in racks / rails**

- Number of shelf levels: 5 PC
- Telescopic shelf rails as optional accessory

#### **Design:**

- Rotary Control, Pop-out controls
- Cavity inner surface: enamel
- Extra large capacity oven

#### **Cleaning:**

- EcoClean Direct: coating of back panel
- Cleaning Assistance (manually)
- Full glass inner door

#### **Comfort:**

- LED-display control (red)
- Electronic clock
- automatic start  
Heating-up control
- Bar handle
- Fast preheat
- Halogen interior lighting
- Water bowl with a volume of 250 ml
- Integral cooling fan

#### **Accessory:**

- 2 x combination grid, 1 x universal pan

#### **Environment and Safety:**

- Low door temperature
- Triple glazed door glazed CoolTouch door
- Child lock

#### **Technical Information**

- Length of mains cable: 120 cm
- Nominal voltage: 220 - 240 V
- Total connected load electric: 2.8 KW
- Energy efficiency rating (acc. EU Nr. 65/2014): A+(at a range of energy efficiency classes from A+++ to D)  
Energy consumption per cycle in conventional mode:0.94 kWh  
Energy consumption per cycle in fan-forced convection mode:0.69 kWh  
Number of cavities: 1 Heat source: electrical Cavity volume:71 l

#### **Dimensions:**

- Appliance dimension (HxWxD): 595 mm x 594 mm x 548 mm
- Niche dimension (HxWxD): 585 mm - 595 mm x 560 mm - 568 mm x 550 mm
- "Please reference the built-in dimensions provided in the installation drawing"
- We recommend you to choose complementary products within Series 4, in order to assure an optimal design combination of your Built-In appliances.

**Series 4, Built-in oven with added steam function, 60 x 60 cm, Black  
HQA534BB3B**

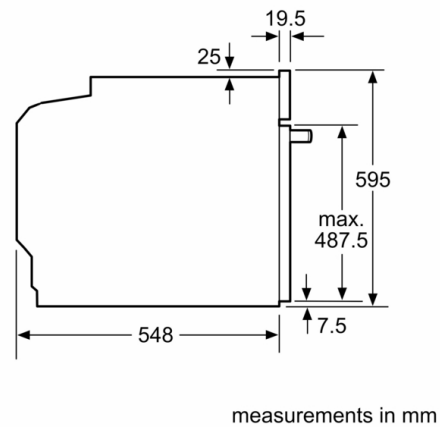
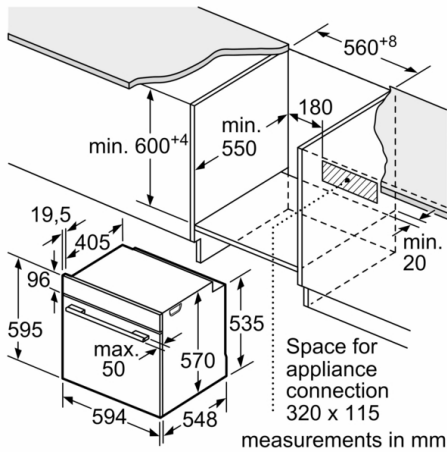

Installation with a hob.

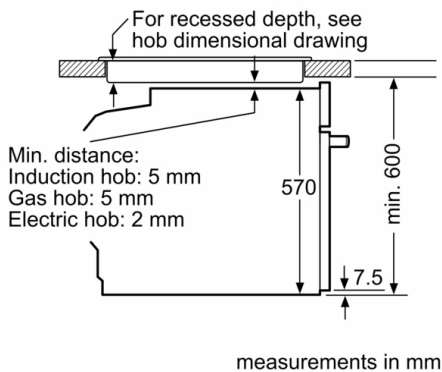

Measurements in mm

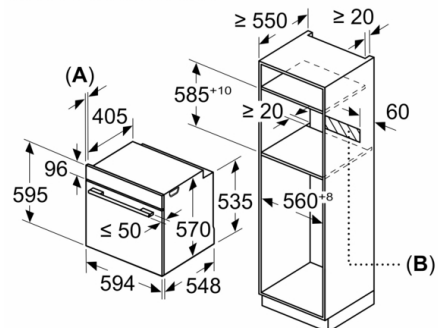

**A:** 19.5 mm  
**B:** Space for appliance connection 320 x 115 mm