

**Series 2, fully-integrated dishwasher,
60 cm
SMV2HTX02G**



Optional accessories

SGZ0BI02 : decorative strips stainless steel 81,5cm
 SGZ1010 : inlet and outlet hose extension
 SGZ8BI00 : Connection rail for divided furniture
 SMZ2056 : Attachment door, stainless steel
 SMZ5003 : Retractable hinge f. high corpus dimens.
 SMZ5300 : GlassSecure Tray

Connected dishwasher with noise reduction at any time via the Home Connect App.

- **ExtraDry:** the extra option for stronger drying performance.
- Hygiene level validated for Eco 50°C and higher levels with Intensive 70°C and Machine Care programmes
-
- **Silence on demand:** up to 30 min noise reduction at any time via the Home Connect App.
- **Home Connect:** home appliances with smart connectivity for an easier everyday life.
- **Favourite function:** personalized function by just one touch.

Technical Data

Energy Efficiency Class (Regulation (EU) 2017/1369): D
 Energy Consumption for 100 cycles Eco Programme: 84 kWh
 Maximum number of place settings: 13
 The water consumption of the eco programme in liters per cycle: 9.0 l
 Programme duration: 4:30 h
 Airborne acoustical noise emissions : 46 dB(A) re 1pW
 Airborne acoustical noise emission class: C
 Cleaning performance: A
 Water consumption: 9.0 l
 Total annual water consumption 220 days: 1980 l
 Built-in / Free-standing: Built-in
 Removable top: No
 Door panel options: Not possible
 Height of removable worktop: 0 mm
 Height of the appliance: 815 mm
 Adjustable feet: Yes - all from front
 Maximum adjustability feet: 60 mm
 Adjustable plinth: Both horizontal and vertical
 Net weight: 31.9 kg
 Gross weight: 34.1 kg
 Connection Rating: 2400 W
 Fuse protection: 10 A
 Voltage: 220-240 V
 Frequency: 50; 60 Hz
 Length electrical supply cord: 175.0 cm
 Plug type: GB plug
 Length inlet hose: 165 cm
 Length outlet hose: 190 cm
 Hidden heating element: Yes
 Water protection system description: Triple water protection 24h
 Child safety devices: No
 Water softener: Yes
 Top basket type: basic
 Adjustable upper basket: No
 Bottom basket type: basic
 3rd Rack: None
 Optional accessories: SGZ0BI02, SGZ1010, SGZ8BI00, SMZ2056, SMZ5003, SMZ5300
 Included accessories 2: Vapor barrier plate
 Number of place settings: 13
 Dimensions of the product (HxWxD): 815 x 598 x 550 mm
 Dimensions of the packed product (HxWxD): 880 x 660 x 670 mm



Series 2, fully-integrated dishwasher, 60 cm SMV2HTX02G

Connected dishwasher with noise reduction at any time via the Home Connect App.

BOSCH - Header 1

- Energy Efficiency Class¹: D
- Energy² / Water³: 84 kWh / 9 litres
- Capacity: 13 place settings
- Programme duration⁴: 4:30 (h:min)
- Noise level: 46 dB(A) re 1 pW
- Noise Efficiency Class: C

BOSCH - Header 2

- 5 programmes: Eco 50 °C, Auto 45-65 °C, Intensive 70 °C, Express 65 °C, Favourite (Pre-Rinse)
- Favourite function
- 4 special options: Remote Start, Extra Dry, Half Load, SpeedPerfect+
- Machine Care Programme
- Add-On functions via Home Connect app: Hygiene Plus, Intensive Zone, Silence on Demand (Quiet now)

BOSCH - Header 3

- Heat exchanger
- AquaSensor
- DosageAssist
- EcoSilence Drive
- Detergent Automation
- Self-cleaning filter system with 3-fold corrugated filter
- Interior tub material: Stainless Steel/Polinox

BOSCH - Header 4

- Normal baskets
- Low friction wheels on bottom basket
- Rack Stopper to prevent derailing of bottom basket
- Cutlery rack in top basket
- Cutlery basket in bottom basket
- 2 cup shelves in top basket
- Glass holder in top basket

BOSCH - Header 5

- Home Connect enabled via WLAN
- Controls on top edge of door
- Panel legend: Plain text (English)
- Info Light (red)
- Acoustic end of cycle indicator
- Electronic delay timer: 3, 6 or 9 hours

BOSCH - Header 6

- AquaStop: Bosch warranty in case of water damage – for the lifetime of the appliance.*
- Glass protection technology

BOSCH - Header 7

- incl. Steam protection for worktop

BOSCH - Header 8

- Product dimensions (HxWxD): 81.5 x 59.8 x 55 cm

¹ Scale of Energy Efficiency Classes from A to G

² Energy consumption in kWh per 100 cycles (in programme Eco 50 °C)

³ Water consumption in litres per cycle (in programme Eco 50 °C)

⁴ Duration of programme Eco 50 °C

* Please find warranty terms under [please insert here the local URL (internet address, e.g. <https://www.bosch-home.com/> but with the direct page with the warranty terms)

Series 2, fully-integrated dishwasher, 60 cm SMV2HTX02G

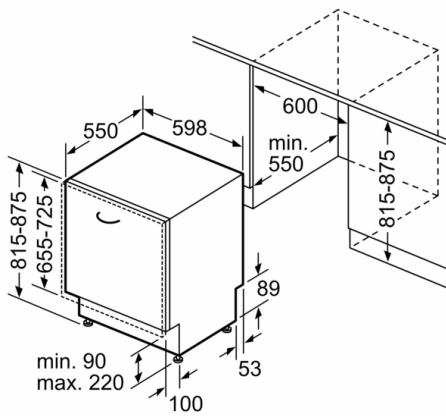

measurements in mm

