

# PHBS9.8CLTDK/1

12NC: F165206

GTIN (EAN) code: 5054645652068

**Hotpoint**

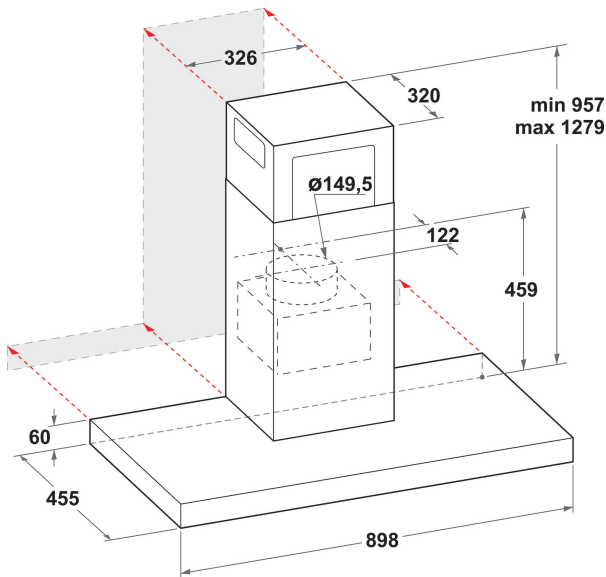

## MAIN FEATURES

Product group	Hood
Colour body	Black
Material body	Stainless steel / glass
Colour chimney	N/A
Material chimney	Stainless steel
Typology	Wall-mounted
Installation type	Wall-mounted
Type of control	Electronic
Type of control settings	-
Decor panel options	Not possible
Motor location	Integrated motor in hood body
Operating Mode	Convertible
Electrical connection rating (W)	255
Current (A)	1,1
Voltage (V)	220-240
Frequency (Hz)	50/60
Length of Electrical Supply Cord (cm)	150
Plug type	No
Chimney height (mm)	-
Height of product, without chimney (mm)	0
Height of the product	1279
Width of the product	898
Depth of the product	454
Minimum niche height	0
Minimum niche width	0
Niche depth	0
Net weight (kg)	31.4

## TECHNICAL FEATURES

Type of manual control devices	Touch control
Type of automatic control devices	-
Number of motors	1
Total power of the motors (W)	0
Number of speed settings: boost option availability	4
Boost presence	Yes
Maximum output air extraction (m <sup>3</sup> /h)	550
Boost position air extraction (m <sup>3</sup> /h)	680
Maximum output recirculating air (m <sup>3</sup> /h)	550
Boost position output recirculating (m <sup>3</sup> /h)	680
Light Control Type	On/Off
Number of lights	2
Type of lamps used	LED
Total power of the lamps (W)	5
Diameter of air outlet (mm)	150
No-return airflow flap	Yes
Grease filter material	Washable stainless steel
Odour filter	Yes

## PERFORMANCES

Sound power at min. speed (2010/30/EU)	53
Sound power at max. speed (2010/30/EU)	70
Noise level with boost position (dB(A) re 1 pW)	75