

**Series 6, American side by side, 178.7 x 90.8 cm, Brushed steel (with anti-fingerprint)
KAD93AIERG**



Included accessories

- 1 x connection hose
- 1 x egg tray

The NoFrost side-by-side fridge-freezer with indoor electronics: provides a modern door display and saves you from defrosting.

- **Ice and Water Dispenser with Tap Connection:** Dispense water and ice.
- **XXL capacity:** extra space for your food when you need it.
- **LED lighting:** keep your groceries in perfect view.
- **Vario Zone:** more flexibility due to variable-use glass shelves and drawers in the freezer compartment.
- **Super Cooling function:** cools new food placed inside faster, thus protecting already cooled food.

Technical Data

Energy Efficiency Class (Regulation (EU) 2017/1369): E
 Average annual energy consumption in kilowatt hour per year (kWh/a): 323 kWh/annum
 Sum of volume of frozen compartments: 191 l
 Sum of volume of chill compartments: 371 l
 Airborne acoustical noise emissions : 42 dB(A) re 1pW
 Airborne acoustical noise emission class: D
 Built-in / Free-standing: Free-standing
 Number of compressors: 1
 Number of independent cooling systems: 1
 Width of the appliance: 908 mm
 Height: 1787 mm
 Depth of the product: 707 mm
 Net weight: 113.2 kg
 Door panel options: Not possible
 Door hinge: left and right
 Number of Adjustable Shelves in fridge compartment: 0
 Shelves for Bottles: Yes
 Frost free system: Fridge and freezer
 Interior ventilator: No
 Reversible Door Hinge: No
 Length electrical supply cord: 170.0 cm
 Noise level: 42 dB(A) re 1pW
 Multi-Flow Air Tower: Yes
 Fast cooling switch: Yes
 Fast freezing function: Yes
 Temperature Controlled Drawer: No
 Humidity Control Drawer: No
 Number of Door Bins - Refrigerator: 5
 Door bin adjustability - Refrigerator: No
 Tilt-out door bins in fridge: No
 Number of Gallon storage: 3
 Number of shelves - Freezer: 0
 Shelf Adjustability - Freezer: Yes
 Connection Rating: 240 W
 Fuse protection: 10 A
 Voltage: 220-240 V
 Frequency: 50 Hz
 Storage Period in Event of Power Failure (h): 3 h
 Color / Material body: Grey
 Door panel options: Not possible
 Noise level: 42 dB(A) re 1pW
 Energy Star Qualified: No
 Required cutout/niche size for installation (in): x
 Dimensions of the packed product: 74.68 x 38.66 x 30.70
 Net weight: 249.000 lbs
 Gross weight: 273.000 lbs



**Series 6, American side by side, 178.7 x 90.8 cm, Brushed steel (with anti-fingerprint)
KAD93AIERG**

The NoFrost side-by-side fridge-freezer with indoor electronics: provides a modern door display and saves you from defrosting.

- NoFrost, Free-standing-refrigerator side-by-side
- Brushed steel anti-fingerprint Doors

Performance and consumption

- Energy Class: E
- Total Volume: 562 l
- Annual Energy Consumption: 323 kWh/a
- Noise Level : 42 dB , D Class

Design and Styling

- Doors Brushed steel anti-fingerprint, side panels Grey
- vertical handle
- Illumination: LED interior light

Convenience & Safety

- NoFrost
- Indoor touch electronic with digital display - at a glance perfectly under control!
- Separate temperature control for cooling and freezing section
- Super Cooling: automatic deactivation
- Super Freezing: manual activation
- Optical and acoustic door open warning system

Ice and Water

- Illuminated water and ice / crushed ice dispenser
- Automatic ice cube maker
- Waterfilter inside

Fridge Compartment

- Net Fridge Volume : 371 l
- Multi Airflow-System
- 5 PC safety glass shelves of which 0 are height adjustable
- 3 door bin(s) high

Freshness System

- 2 MultiBox drawers on rails - Transparent drawers with a corrugated bottom, ideal for storing fruits and vegetables.

Freezer

- Net Freezer Volume : 191 l
- Freezing capacity 24h: 12 kg
- Fast Freeze Facility
- 2 transparent freezer drawers
- 3 door trays in the freezing compartment

Technical Information

- Appliance on 4 wheels, feet adjustable
- Climate Class: SN-T
- Connection Length (water supply):300 cm
- Length of power cord: 170 cm

Dimensions

- Appliance Dimensions (H x W x D): 178.7 cm x 90.8 cm x 70.7 cm
- Nominal voltage: 220 - 240 V

Accessories

- connection hose
egg tray
- connection hose
egg tray

Special Accessories

Country Specific Options

- Based on the results of the standard 24-hour test. Actual consumption depends on usage/position of the appliance.

Environment and Safety

Installation

General Information

**Series 6, American side by side, 178.7
x 90.8 cm, Brushed steel (with anti-
fingerprint)
KAD93AIERG**

Measurements in mm

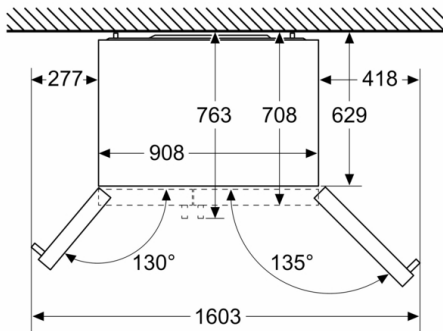

measurements in mm

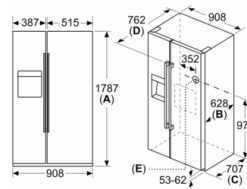

Specifications	
A	Front is adjustable from 1783 to 1792
B	Cabinet depth
C	Depth incl. door, without handle
D	Depth incl. door, with handle
E	Water connection to the appliance

Measurements in mm

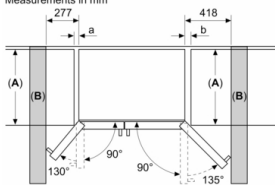

A	a	b
≤ 600	50	50
600 < A ≤ 650	50	50
650 < A ≤ 700	53	96
> 700	277	418

A: Kitchen cabinet or worktop depth

B: Wall
Drawers can be pulled out with door open to 90°

Drawers can be taken out with door completely opened