

Your Kenwood Mini Chopper is suitable for chopping a range of foods including nuts, breadcrumbs, meat (raw and cooked), onions, garlic and fruit purée.

before using your Kenwood appliance

- Read these instructions carefully and retain for future reference.
- Remove all packaging and any labels.

safety

- The blades are sharp, handle with care. **Hold the knife blade at the top away from the cutting edge, both when handling and cleaning.**
- Switch off and unplug:
 - before fitting or removing parts
 - after use
 - before cleaning.
- Keep hands and utensils out of the bowl whilst connected to the power supply.
- Remove the knife blade before emptying the bowl.
- Never use a damaged appliance. Get it checked or repaired: see 'service'.
- Never let the power unit, cord or plug get wet.
- Don't let excess cord hang over the edge of a table or worktop or touch hot surfaces.
- Never leave the appliance on unattended.
- This appliance is not suitable for processing very hard foods e.g ice-cubes, coffee beans, hard spices, grinding granulated sugar to caster sugar, or processing hot liquids.
- Misuse of your food chopper can result in injury.

- This appliance is not intended for use by persons (including children) with reduced physical, sensory or mental capabilities, or lack of experience and knowledge, unless they have been given supervision or instruction concerning use of the appliance by a person responsible for their safety.
- Children should be supervised to ensure that they do not play with the appliance.
- Only use the appliance for its intended domestic use. Kenwood will not accept any liability if the appliance is subject to improper use, or failure to comply with these instructions.

before plugging in

- Make sure your electricity supply is the same as the one shown on the underside of the power unit.

Important - UK only

- The wires in the cord are coloured as follows:
Blue = Neutral, Brown = Live.
 - The appliance must be protected by a 3A approved (BS1362) fuse.
- Note:**
- For non-rewireable plugs the fuse cover MUST be refitted when replacing the fuse. If the fuse cover is lost then the plug must not be used until a replacement can be obtained. The correct fuse cover is identified by colour and a replacement may be obtained from your Kenwood Authorised Repairer (see Service).
 - If a non-rewireable plug is cut off it must be DESTROYED IMMEDIATELY. An electric shock hazard may arise if an unwanted non-rewireable plug is inadvertently inserted into a 13A socket outlet.
 - This appliance complies with European Economic Community Directive 89/336/EEC

before using for the first time

- 1 Remove all packaging.
- 2 Wash the parts: see 'cleaning'.

key

- ① lid
- ② knife blade
- ③ bowl
- ④ drive shaft
- ⑤ control button
- ⑥ power unit

to use your mini chopper

- 1 Fit the bowl onto the power unit – turn in a clockwise direction until it locks (a).
- 2 Fit the blade (b).
- 3 Place the lid onto the bowl and turn clockwise until it locks (c).

Your mini chopper will not operate unless the bowl and lid are correctly engaged.

- 4 Switch on by continuously pressing the control button half way down for speed 1 and all the way down for speed 2. Alternatively use an on/off pulse action which will operate the motor and keep it running for as long as the button is held down.
- 5 Reverse the above procedure to remove the lid, blade and bowl.

hints

- **IMPORTANT** - If preparing food for babies or young children, always check that the ingredients are thoroughly blended before feeding.
- **When mixing liquid ingredients fill the bowl no more than ½ full.**
- When processing heavy ingredients, avoid running the motor continuously for periods over 10 seconds without resting.

- Beware of overprocessing some ingredients. Stop and check the consistency frequently.
- Various spices such as Cloves, Dill and Cummin seeds can have an adverse effect on the plastic of your mini chopper and should not be processed.
- To ensure even processing, stop and scrape down any food from the side of the bowl with a plastic spatula.
- The best results are obtained by chopping small quantities at one time.
- Cut foods into small pieces. A large load or large pieces may cause uneven results.
- Before chopping nuts, breadcrumbs etc., ensure that both the food and the blade, bowl and lid are thoroughly dry.

recipes

French Dressing

1.25ml/¼ tsp salt
pinch pepper
1.25ml/¼ tsp dry mustard
1.25ml/¼ tsp sugar
15ml/1 tbsp vinegar
30ml/2 tbsp salad oil

Place all the ingredients into the mini chopper and mix until well blended. Use as desired. Note: the oil will separate out on standing, so if necessary mix the dressing immediately before it is required.

Smoked Mackerel Pâté

50g/2oz smoked mackerel
25g/1oz creamed cheese
salt, pepper and lemon juice (optional)

Process the mackerel until chopped. Scrape down, add the cream cheese and seasonings if desired. Blend until smooth.

processing guide

Food	Maximum capacity	Preparation
Herbs - parsley/mint	10g	Herbs are best chopped when clean and dry.
Hard boiled eggs	2	Cut in half. Process until chopped
Nuts eg almonds, walnuts	50g/2oz	Process until chopped. (Note: the consistency of fine ground almonds will not be achievable).
Breadcrumbs	50g/2oz	Cut into ½"/1cm cubes. Process until of the desired consistency.
Biscuit crumbs	50g/2oz	Break into pieces and process until of the desired consistency.
Uncooked meat	150g/6oz	Cut into ½"/1cm cubes and process until of the desired consistency. Use lean meat.
Cooked meat and fish	150g/6oz	Cut into ½"/1cm cubes. Pulse until of the desired consistency.
Vegetables - tomatoes	1-2	Skin and quarter. Pulse to a purée
mushrooms	1-2	Skin and quarter. Process until chopped
pepper	½	½"/1cm pieces. Process until chopped
Apple Purée	100g/4oz cooked apple	Process until smooth.
Garlic cloves	1-10	Pulse until chopped
Fresh root ginger	25g/1oz	Cut into small pieces ¼-½"/½-1cm and pulse until chopped

Avocado Dip

½ ripe avocado (cut into ½"/1cm cubes)

½ garlic clove

50g/2oz natural Greek styled yoghurt

1-2 sprigs fresh dill, roughly chopped

Place all ingredients into the bowl and blend until smooth.

cleaning

- Always switch off and unplug before cleaning.
- Handle the blade with care - it is extremely sharp.
- Some foods may discolour the plastic. This is perfectly normal and won't harm the plastic or affect the flavour of your food. Rub with a cloth dipped in vegetable oil to remove the discolouration.

power unit

- Wipe with a damp cloth, then dry.

lid/bowl/knife blade

- Wash by hand, then dry.
- Alternatively they can be washed on the top rack of your dishwasher.
- The parts are unsuitable for use in a Steam Steriliser. Instead use a sterilising solution in accordance with the sterilising solutions manufacturer's instructions.

service and customer care

- If the cord is damaged it must, for safety reasons, be replaced by KENWOOD or an authorised KENWOOD repairer.

UK

If you need help with:

- using your appliance
 - servicing or repairs (in or out of guarantee)
- ☎ call Kenwood Customer Care on **023 92392333**. Have your **model number ready** - it's located on the underside of the power unit.

spares and attachments

- ☎ call 0870 2413653.

other countries

- Contact the shop where you bought your appliance.

guarantee (UK only)

If your food chopper goes wrong within one year from the date you bought it, we will repair it (or replace it if necessary) free of charge provided:

- you have not misused, neglected or damaged it;
- it has not been modified (unless by Kenwood);
- it is not second-hand;
- it has not been used commercially;
- you have not fitted a plug incorrectly; and
- **you supply your receipt to show when you bought it.**

This guarantee does not affect your statutory rights.

KENWOOD

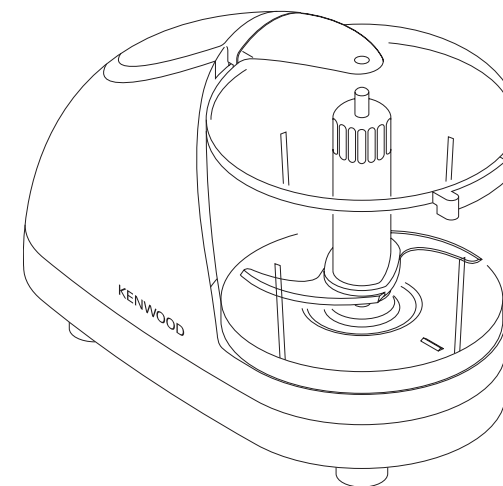

CH180A

