

KETER

Create amazing spaces™

STORAGE BENCH

227L / 60 US GAL

USER MANUAL | MODE D'EMPLOI | MANUAL DEL USUARIO | MONTAGEANLEITUNG | MONTAGEHANDLEIDING
 | MANUALE PER L'UTENTE | MANUAL DO UTILIZADOR |取扱説明書 | 조립설명서

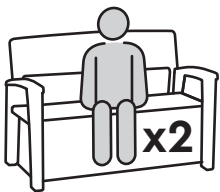
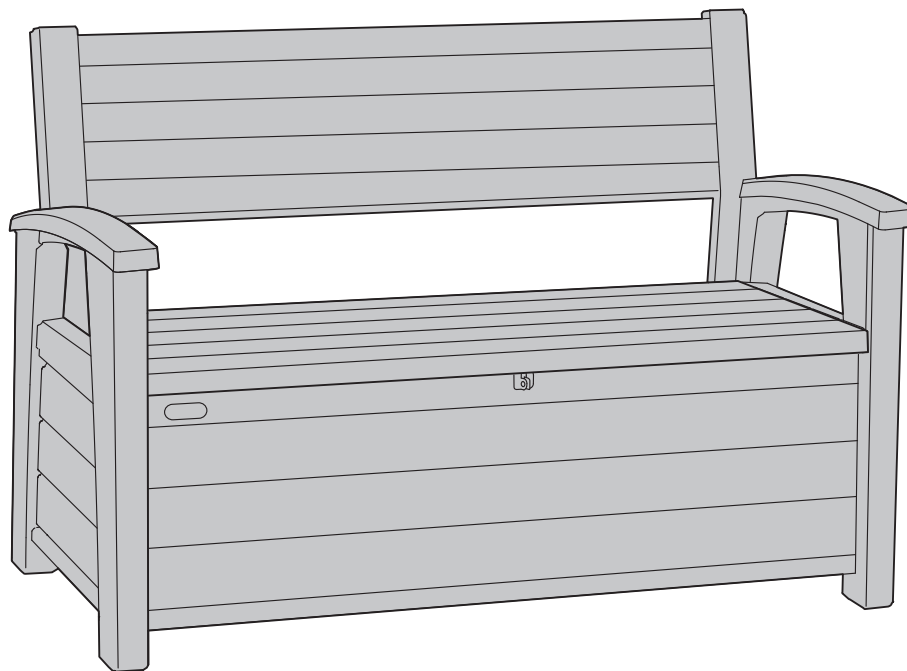

272 Kg
600 Lb



35 Kg
71 Lb

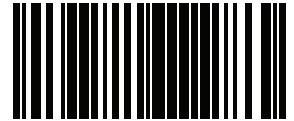
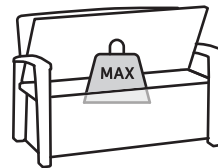

5027027

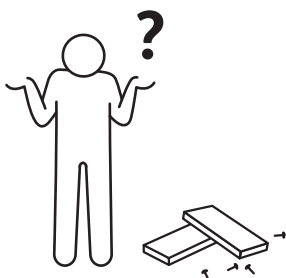

WWW.KETER.COM

US, Canada: (EN/FR)

Tel: +1877-638-7056, NACS@keter.com
 Mon - Fri | 8am - 6pm ET / Lundi-Vendredi 8h -18h
 Sat - Sun | 9am - 6pm ET / Samedi-Dimanche 9h-18h

UK

Tel: +44-121-506-0008, CSUK@keter.com
 Mon - Fri | 8:30am - 5pm

고객센터

Tel: 031-7672492, info@keter.cp.kr
 FAX: 031-717-2497

For other European countries see the last page
 Autres pays européens, voir la dernière page
 Para otros países europeos vea la última página

BEFORE STARTING ASSEMBLY | AVANT DE COMMENCER LE MONTAGE | ANTES DE EMPEZAR EL ARMADO | VOR MONTAGEBEGINN | VOORDAT U BEGINT TE MONTEREN | PRIMA DI INIZIARE L'ASSEMBLAGGIO | ANTES DE INICIAR A MONTAGEM | 組み立てる前に | 조립을 시작하기 전에 확인할 내용

Some parts have metal edges. Please be careful when handling components. Always wear work gloves | Certaines pièces ont des bords en métal. Soyez prudent en les manipulant. Portez toujours des gants de travail | Manche Teile haben Stahlkanten, bitte seien Sie vorsichtig beim Umgang mit diesen. Tragen Sie bei der Montage des Gartenschuppens oder Wartungsarbeiten stets Arbeitshandschuhe | Algunas partes incluyen bordes metálicos. Tenga cuidado al manejar estos componentes. Use siempre guantes de trabajo | Sommige onderdelen hebben stalen randen. Wees voorzichtig met het omgaan met deze onderdelen. Draag altijd werkhandschoenen | Alcune parti presentano bordi in acciaio. Fare attenzione nel maneggiare i componenti. Indossare sempre guanti da lavoro | Algumas peças têm extremidades de aço. Tenha cuidado ao manusear este componentes. Utilize sempre luvas e óculos de proteção | 鋭いメタル部品が含まれていますのでご注意ください。作業手袋着用をお勧めいたします | 안전을 위해 반드시 작업용 장갑을 착용하십시오.



WICHTIG, FÜR SPÄTERE BEZUGNAHME AUFBEWAHREN: SORGFÄLTIG LESEN

Once the product is assembled, it can not be disassembled | Une fois le produit assemblé, il ne peut plus être démonté | Sobald das Produkt montiert wurde, kann es nicht wieder zerlegt werden | Una vez montado, el producto no podrá ser desmontado | Als het product eenmaal is gemonteerd, kan het niet meer worden gedemonteerd | Una volta montato, il prodotto non può più essere smontato | Uma vez montado, o produto não pode ser desmontado | 제품을 조립하면, 다시 분해할 수 없습니다 | 一度製品が組み立てられたら、解体することはできません

Retain for future reference. Read carefully. For domestic use | * à monter soi-même * IMPORTANT, À CONSERVER POUR CONSULTATION ULTÉRIEURE : À LIRE ATTENTIVEMENT. Pour usage domestique | Wichtig, Für spätere bezugnahme aufbewahren. sorgfältig lesen. Für den privatgebrauch | Guardar para referencia futura. Leer atentamente. Para uso doméstico | Conservare per riferimenti futuri. Leggere attentamente. Per uso domestico | Bewaar voor toekomstige raadpleging. Lees nauwkeurig. Voor huishoudelijk gebruik. | Guarde para referência futura. Ler cuidadosamente. Para utilização doméstica. | 今後の参照の為保管してください。注意してお読みください。一般家庭用製品。 | 조립 설명서를 보관하시고 주의 깊게 읽어주십시오. 상업적 용도가 아님.

"Keter" Créez des espaces de vie incroyables











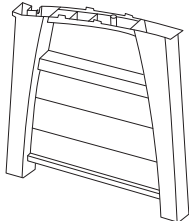
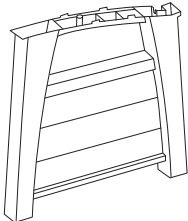
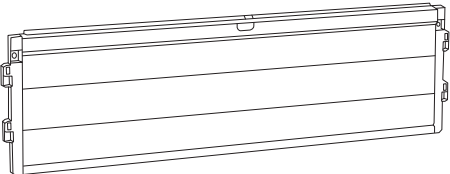
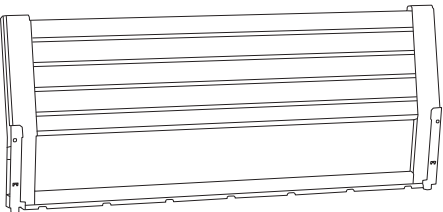
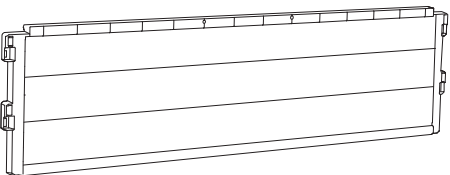
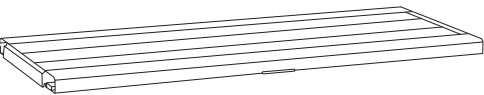
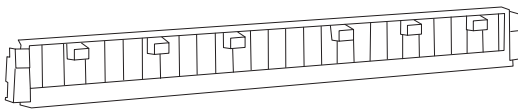
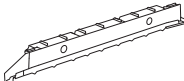
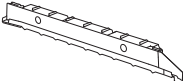



Digital manual | Manuel numérique | Manual digital |
Digitale Anleitung | Digitale handleiding |
Manuale digitale | Manual digital | デジタルマニュアル

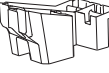
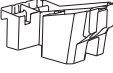

<https://g.keter.com/Hudson>

ASSEMBLY PARTS | PIÈCES À ASSEMBLER | PIEZAS DE ENSAMBLE | MONTAGETEILE | PARTI DA MONTARE | ONDERDELEN | PEÇAS DE MONTAGEM | 部品一覧 | 조립 부품

Please check all parts and components to ensure that there are no damages or missing items BEFORE starting the construction of the product | Assurez-vous que les parties et les éléments ne sont pas endommagés et qu'aucun ne manque AVANT de commencer le montage de ce produit | Bitte überprüfen Sie alle Einzelteile und jegliches Zubehör, um sicherzugehen, dass keine Teile beschädigt sind oder fehlen, BEVOR Sie mit der Montage des Produkts beginnen | Controleer alle onderdelen en componenten om te verzekeren dat er geen schade of ontbrekende items zijn VOOR dat u het product in elkaar begint te zetten | ANTES de comenzar la construcción del producto, compruebe todas las partes y componentes para asegurarse de que no hay daños y de que no falta ningún elemento | Si prega di controllare tutti i pezzi ed i componenti per accertarsi che non ci siano danni o elementi mancanti PRIMA di montare il prodotto | Por favor, verifique todas as peças e componentes para garantir que não há danos ou itens incompletos ANTES de iniciar a construção do produto | 組立を開始する際全ての部品が揃っていて不良が無いことを事前にご確認下さい | 제품을 조립하기 전에 문제가 없는지 모든 부품을 확인해주시시오.

					
WSL (x1)	WSR (x1)	WPF (x1)			
					
WBR (x1)		WBP (x1)			
					
EP (x1)		WLP (x1)			
					
AC (x1)		MP (x2)			
					
1WL (x1)	1WR (x1)	WFS (x1)	WBS (x1)		
					
CFL (x1)	CFR (x1)	AL (x1)	AR (x1)		
					
CBL (x1)	CBR (x1)	LN (x1)	RN (x1)		
					
LA (x2)	LB (x2)	CP (x2)	WL1 (x1)	WL2 (x1)	S (x27)

1



WSL (x1)



LN (x1)



S (x1)

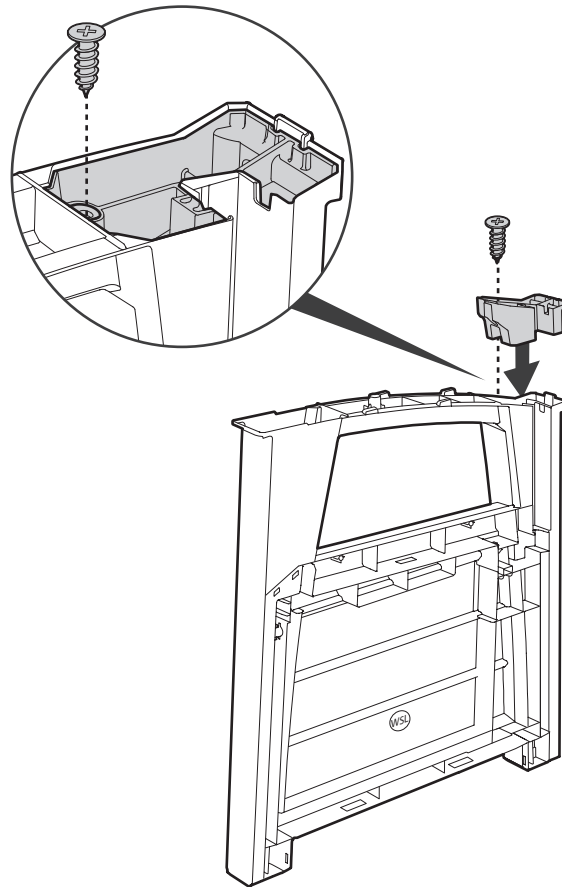

2



WSR (x1)



RN (x1)



S (x1)

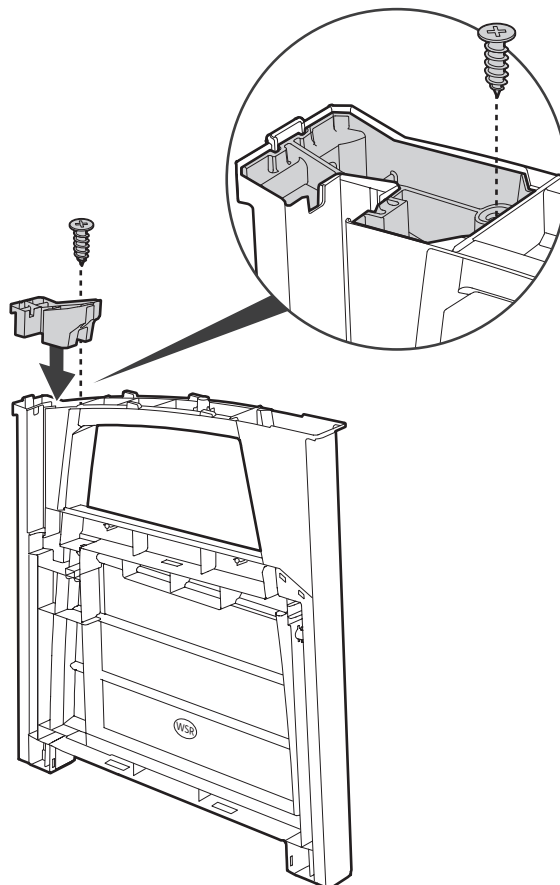

3

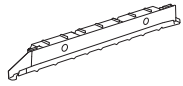

1WL (x1)



S (x2)



WSL (x1)

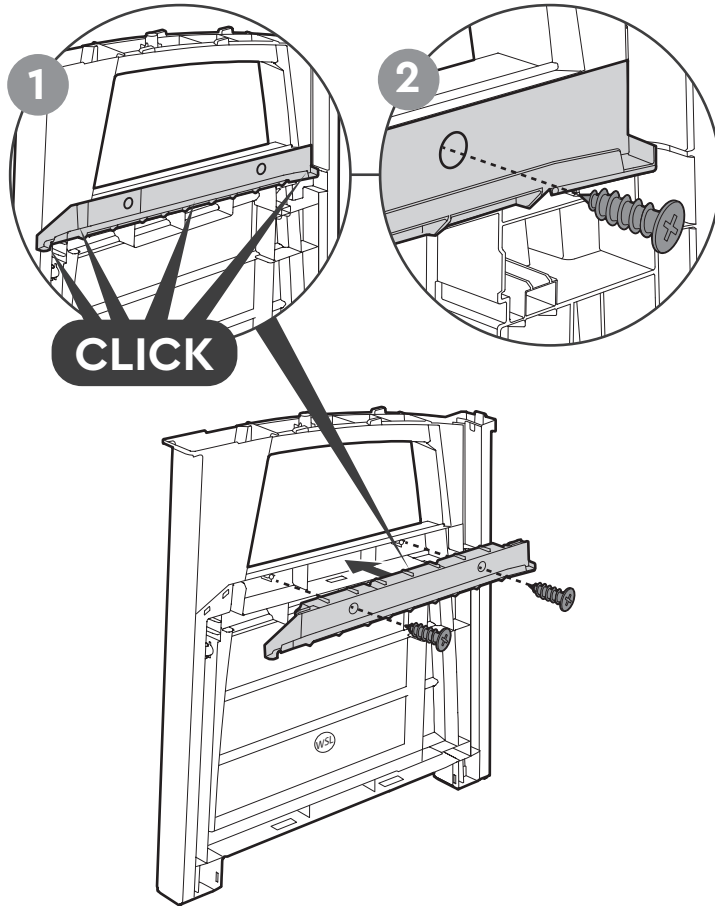

4

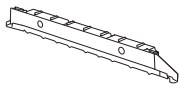

1WR (x1)



S (x2)



WSR (x1)

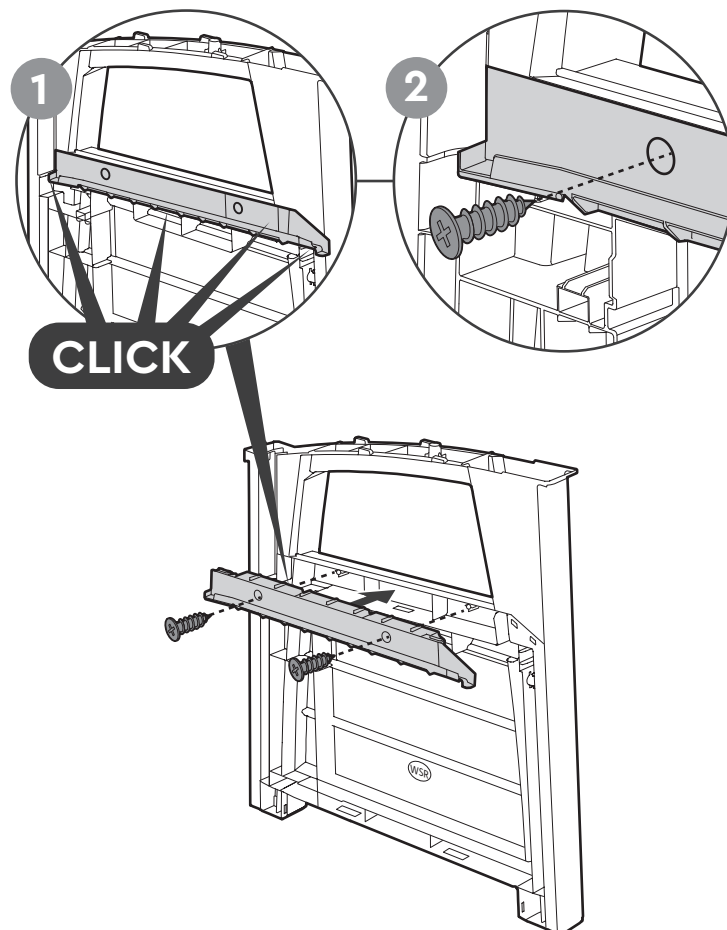

5



LA (x2)



LB (x2)

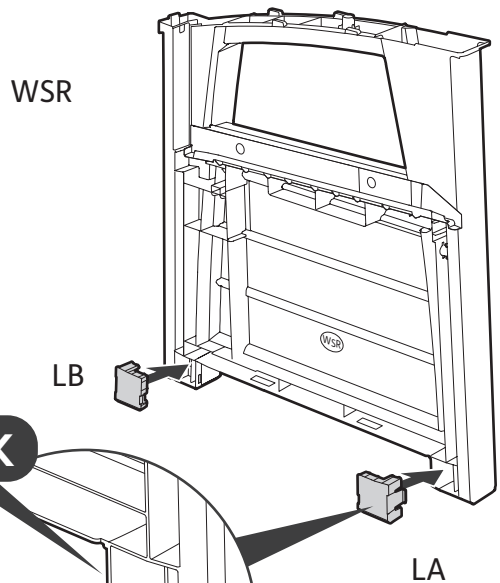
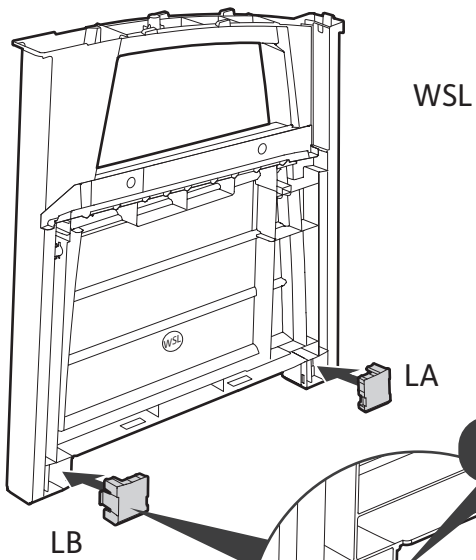

6

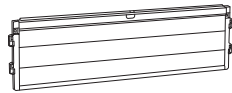

WPF (x1)



MP (x1)

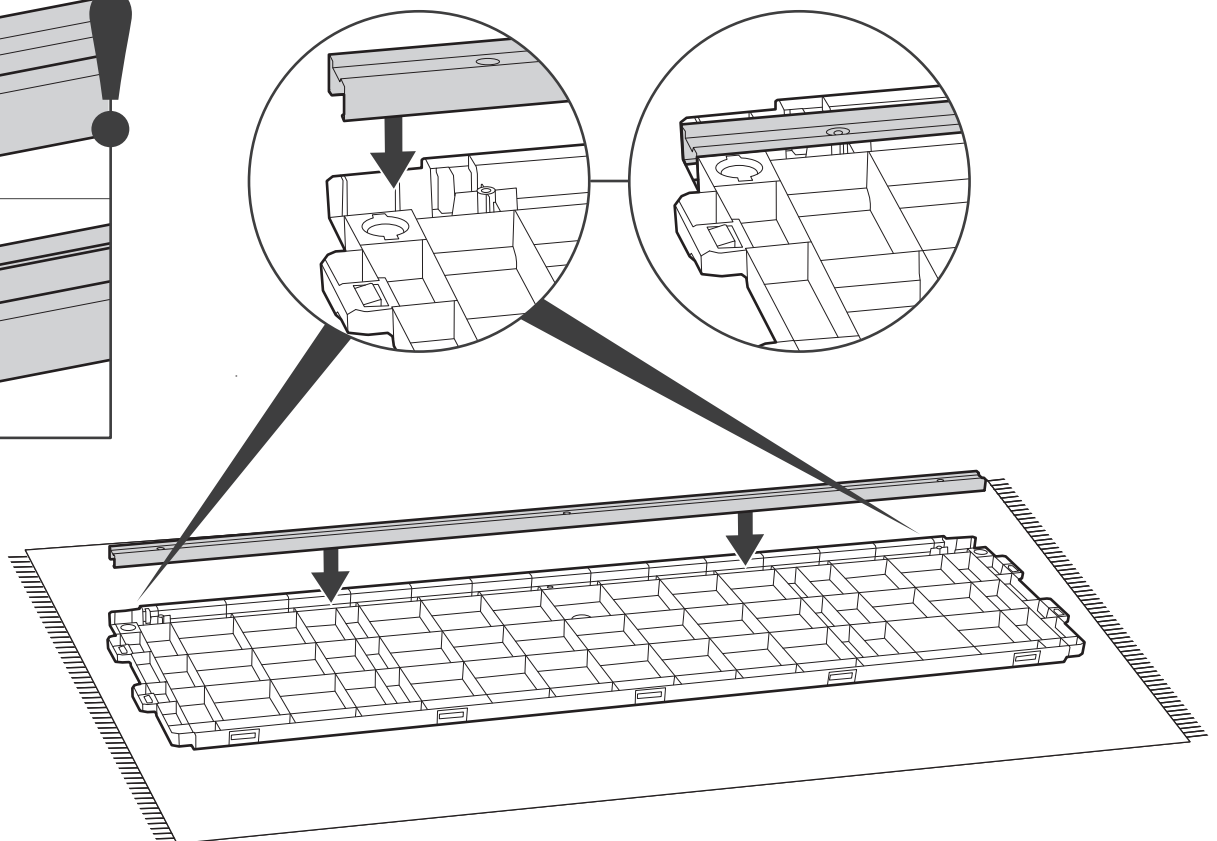
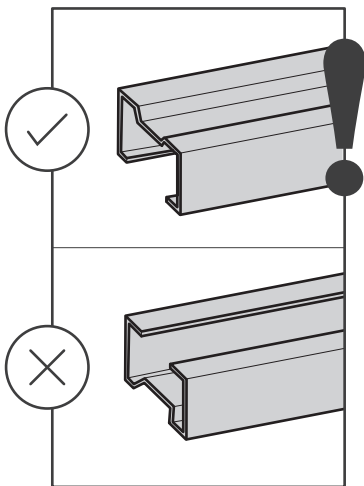

7



WPF+MP

S (x2)

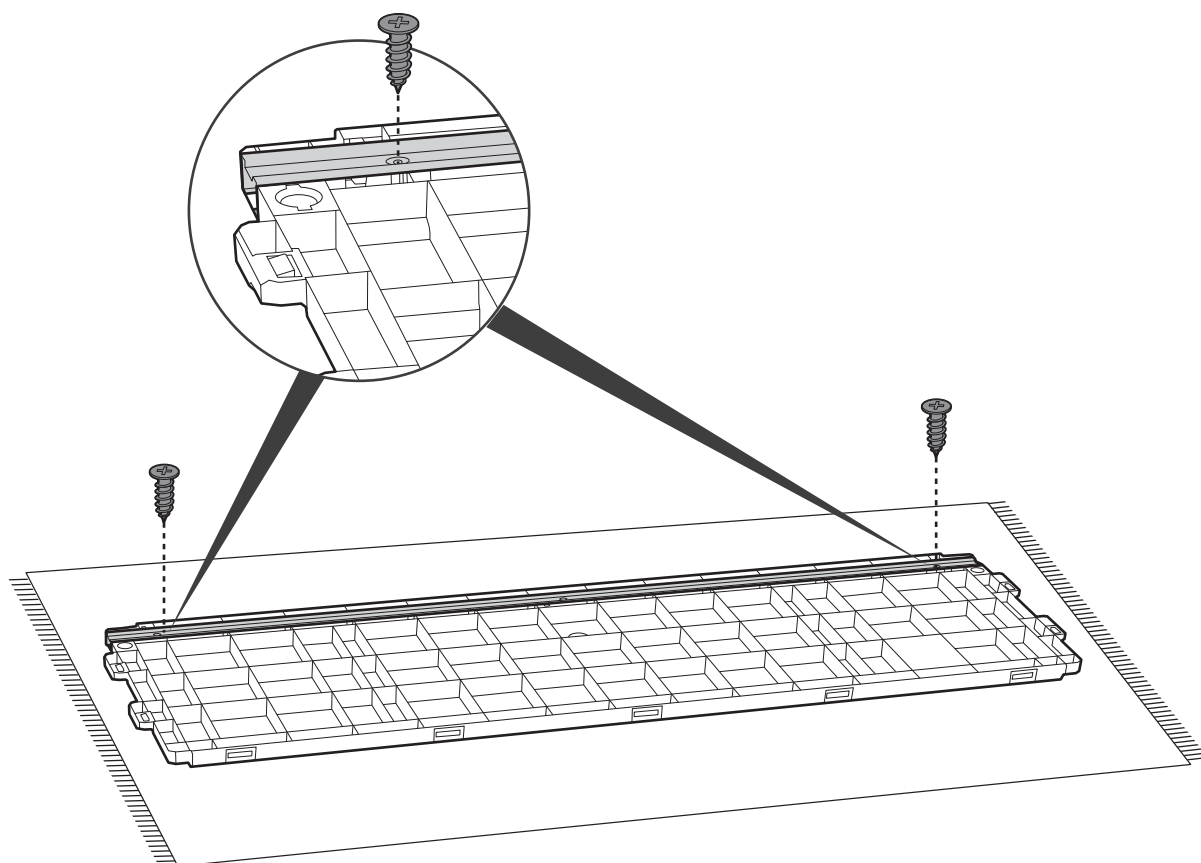

8



AC (x1)



MP (x1)

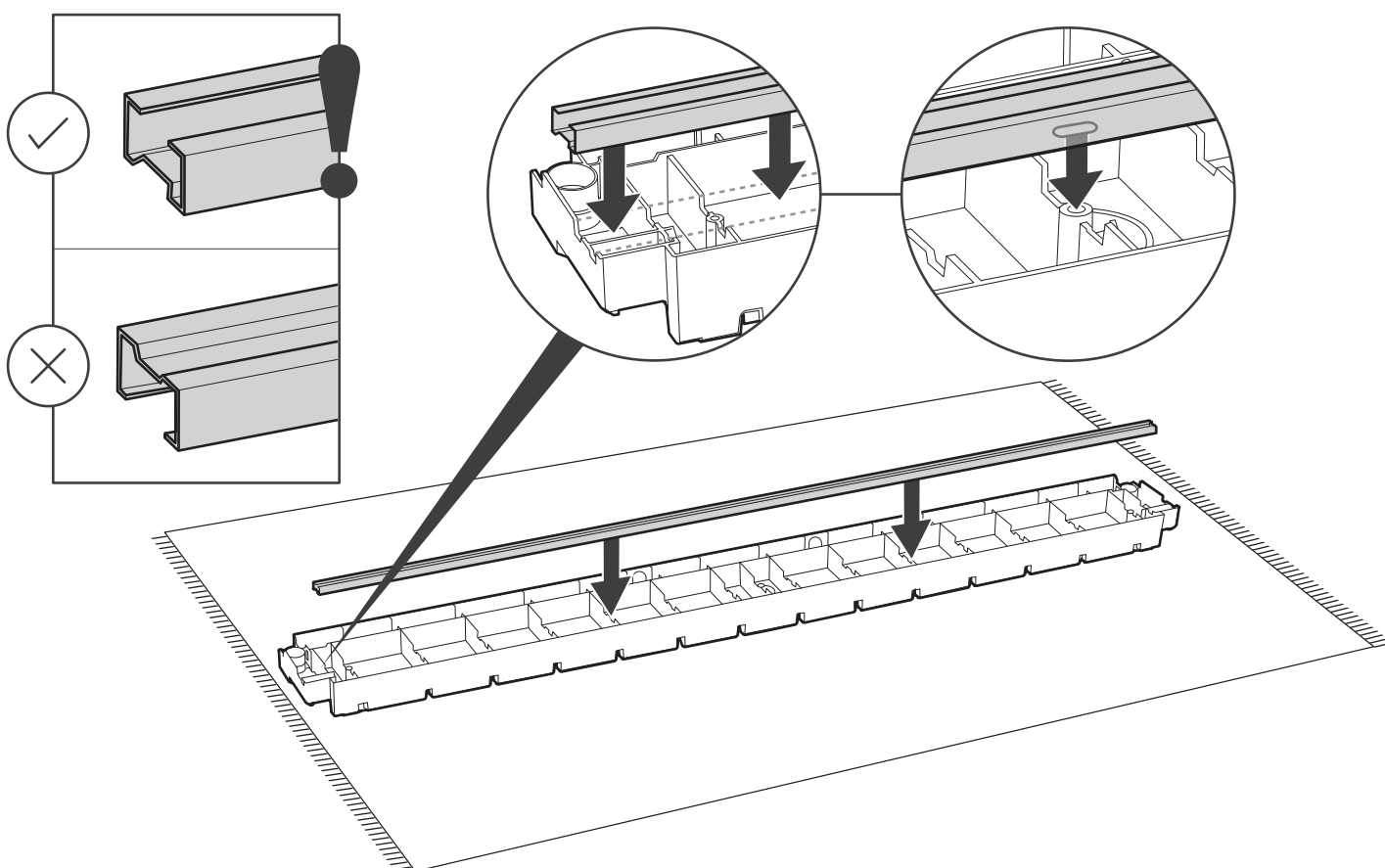

9

S (x3)

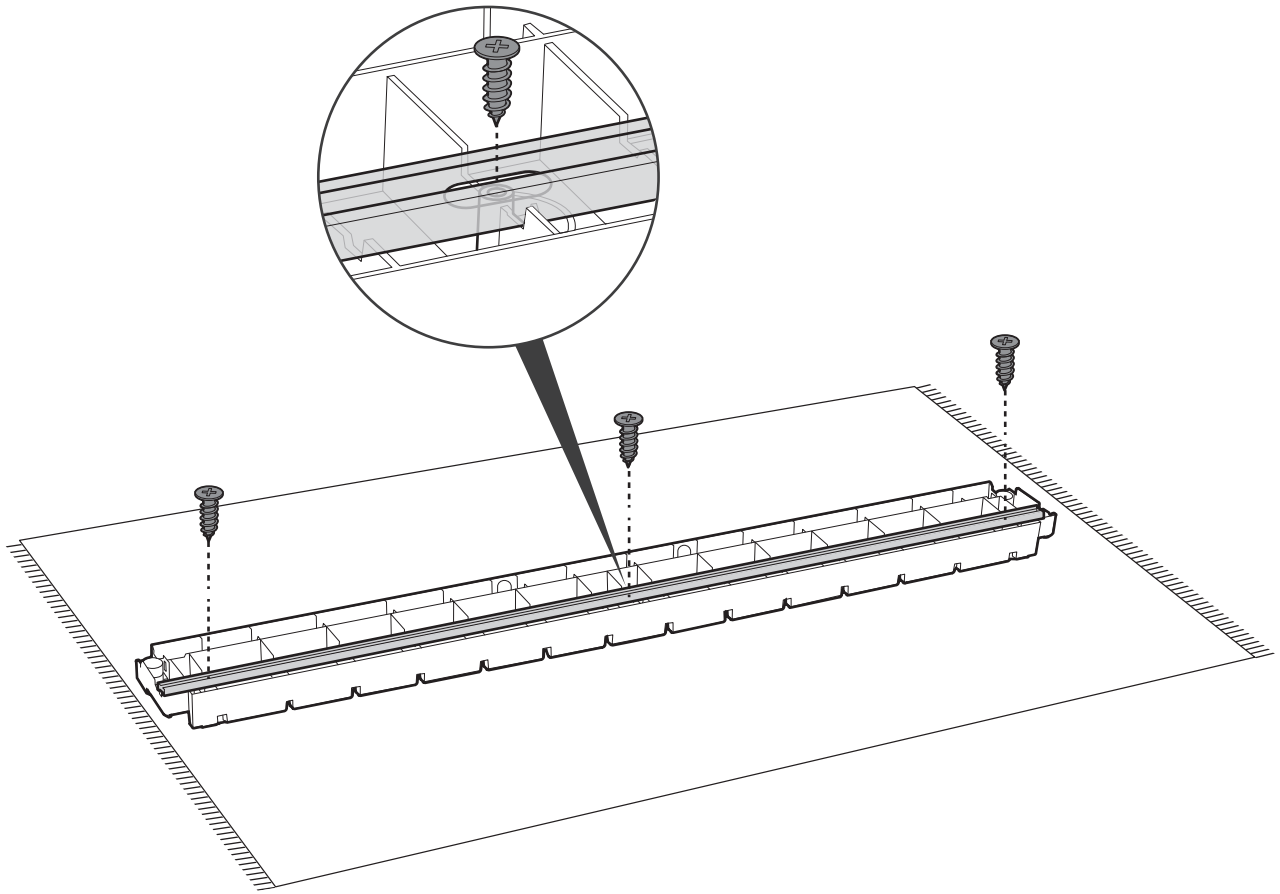

10

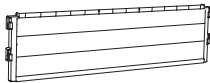

WBP (x1)

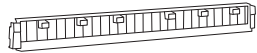

AC (x1)

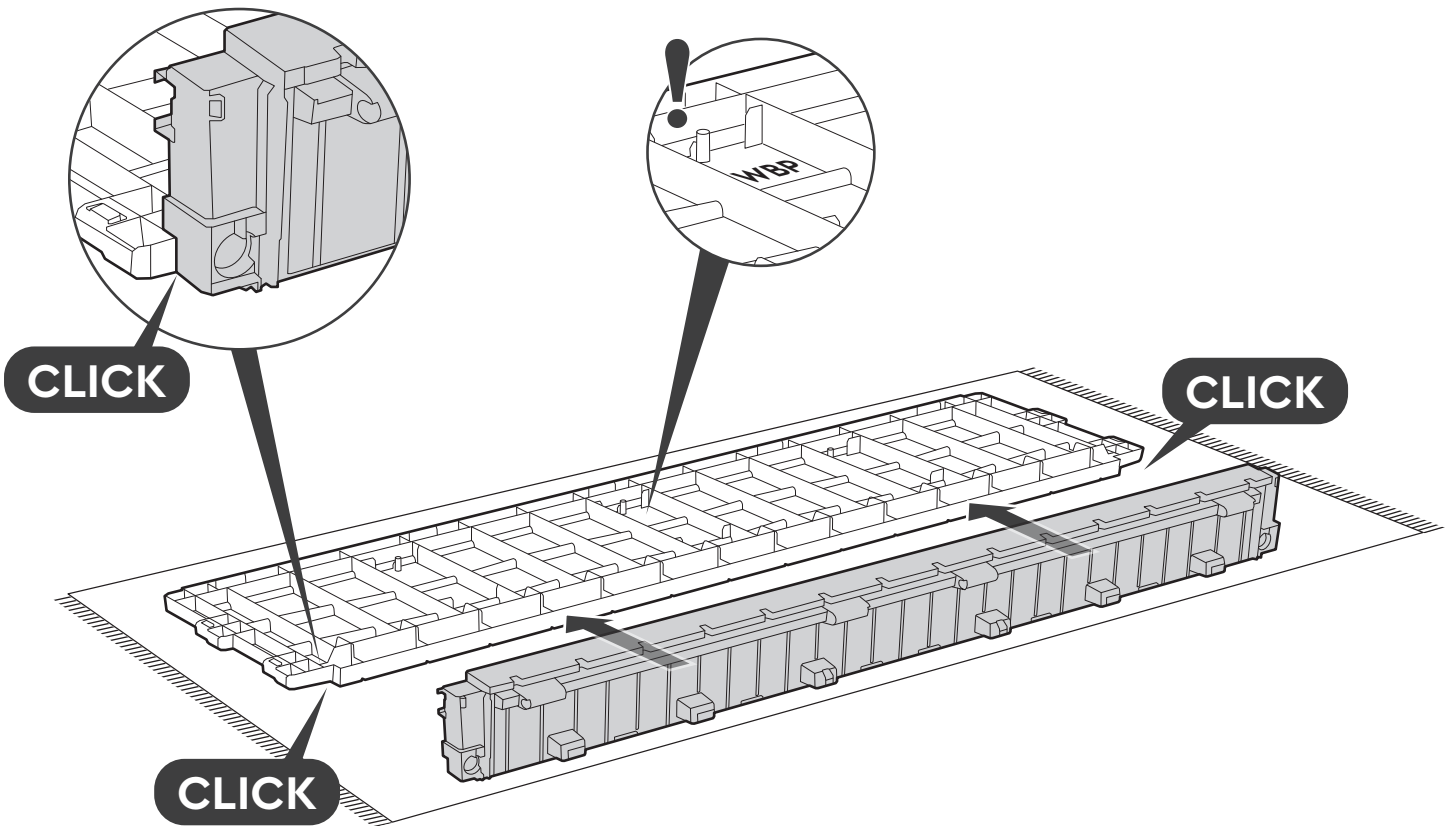

11

S (x2)

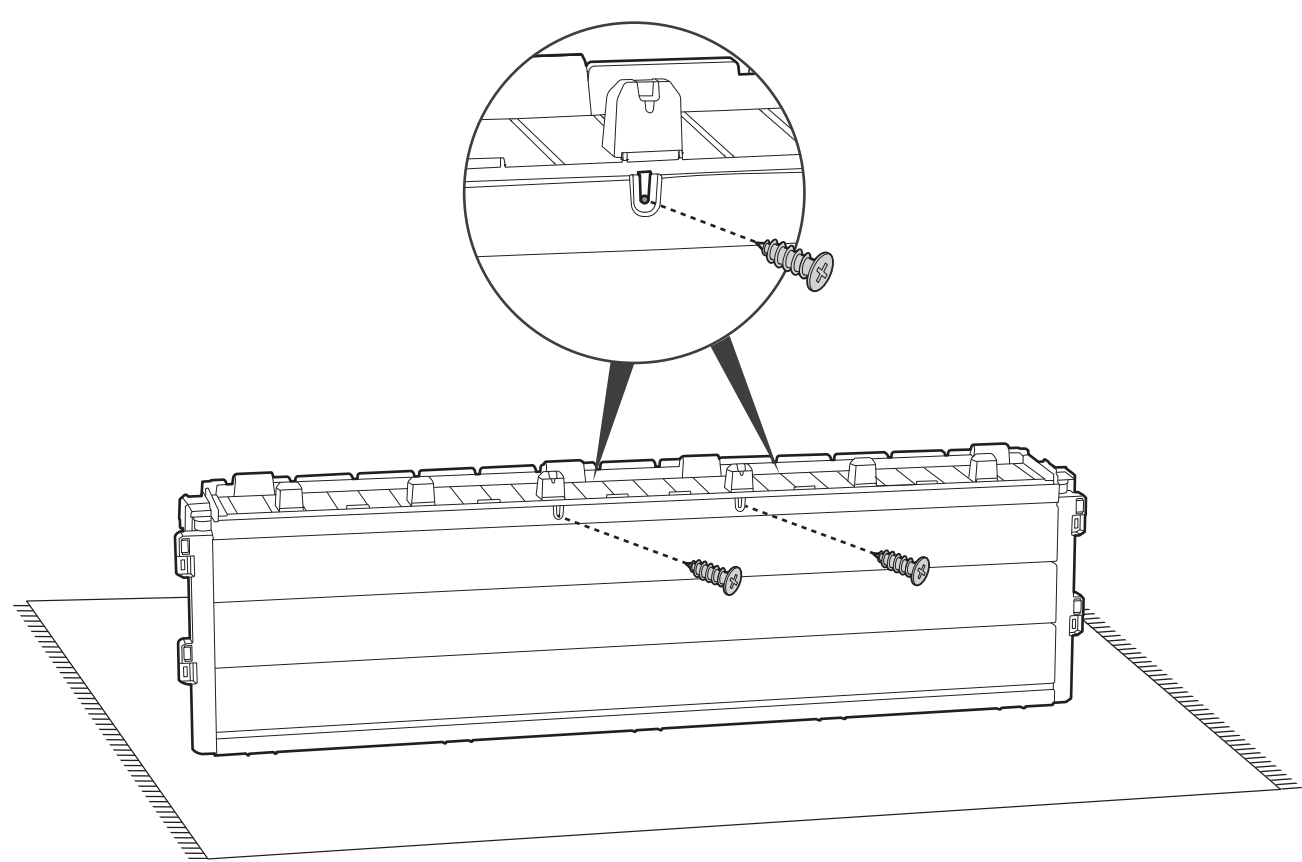

12

EP (x1)

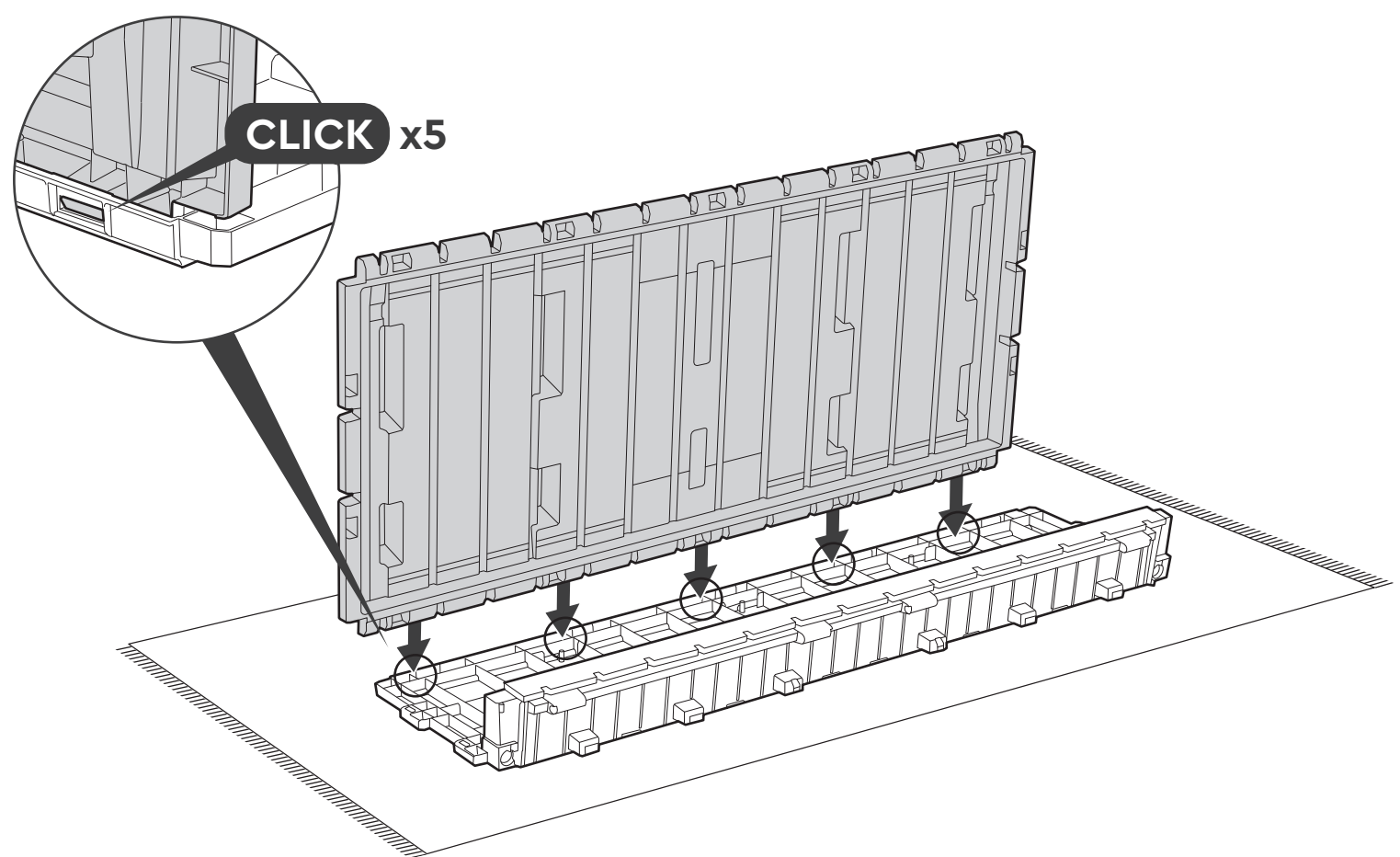

13



WBS (x1)

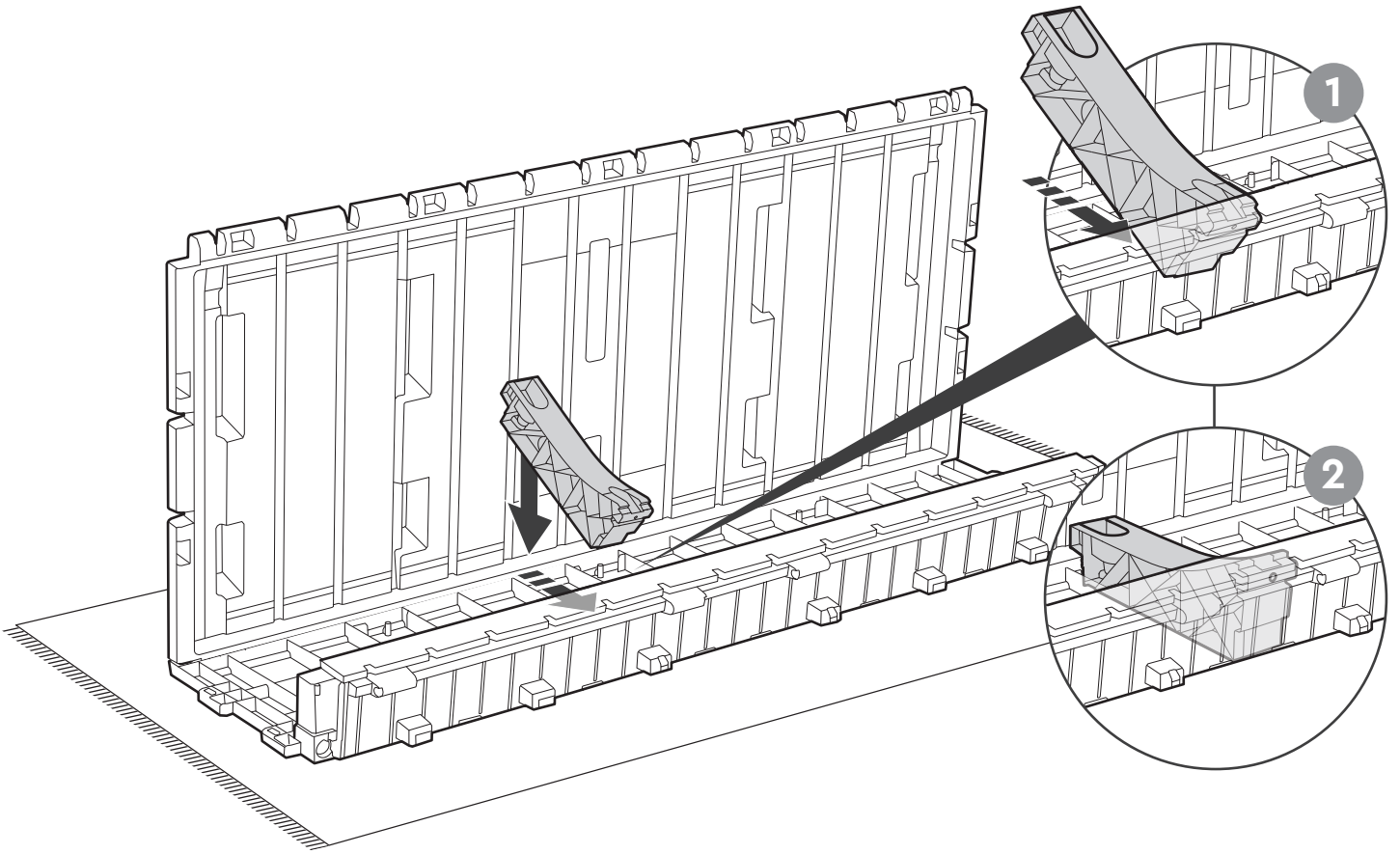

14



S (x1)

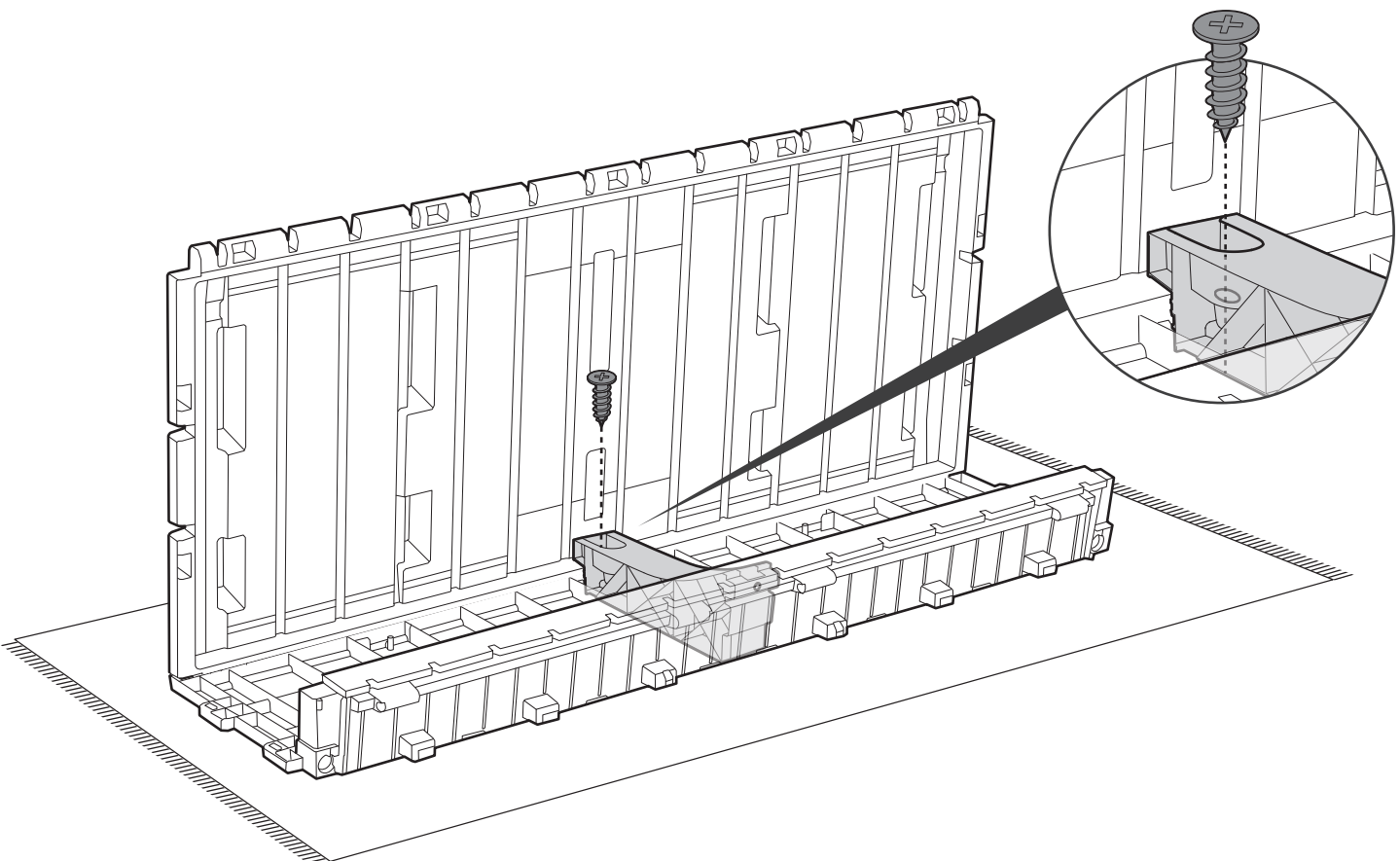

15



WFS (x1)



S (x1)

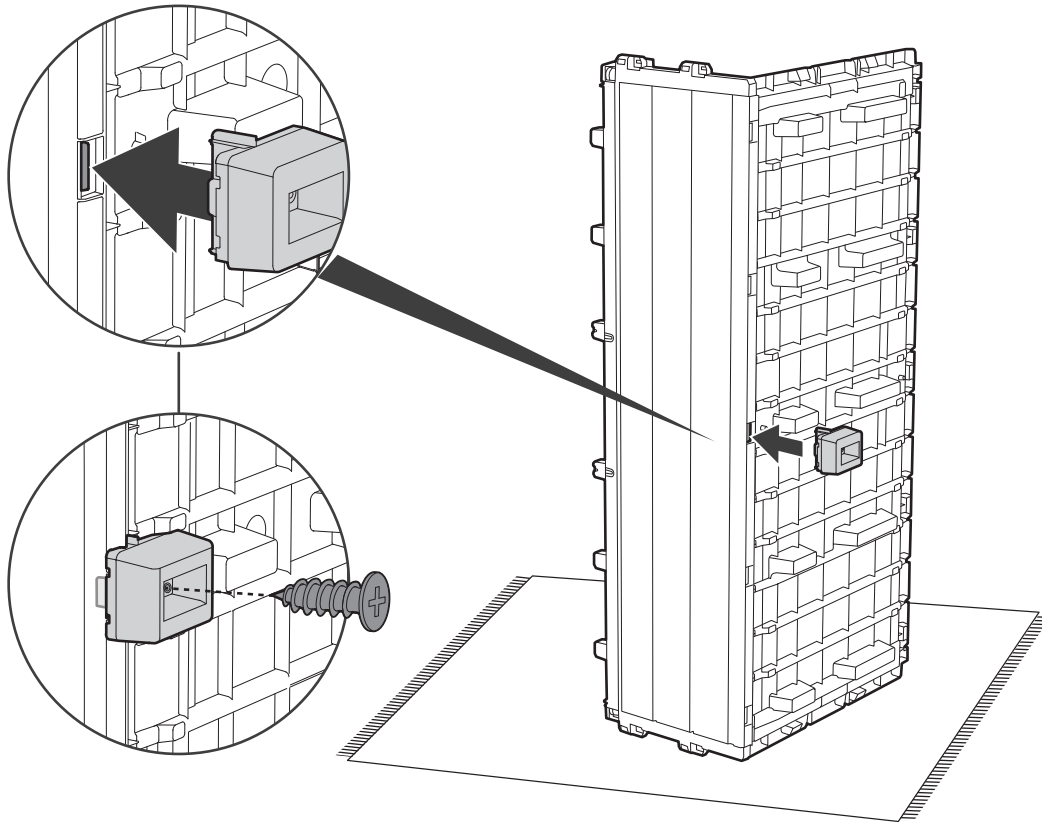

16

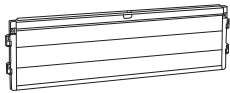

WPF (x1)



AC+WBP+EP (x1)

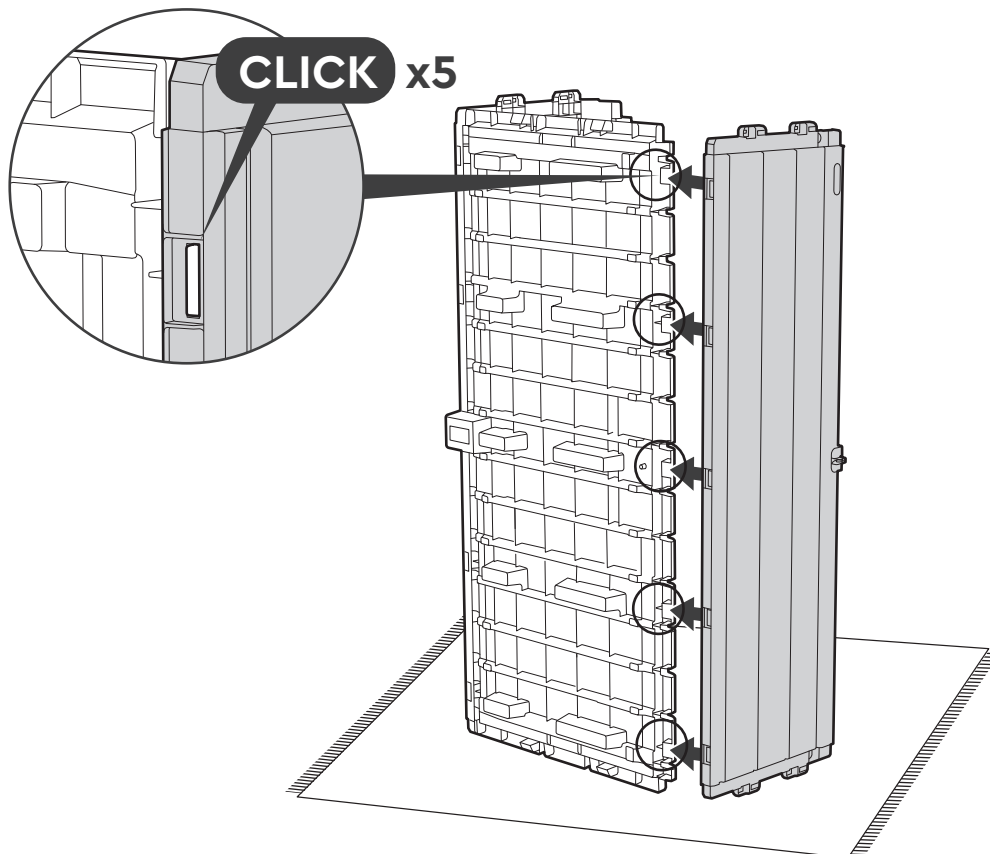

17



WSR (x1)

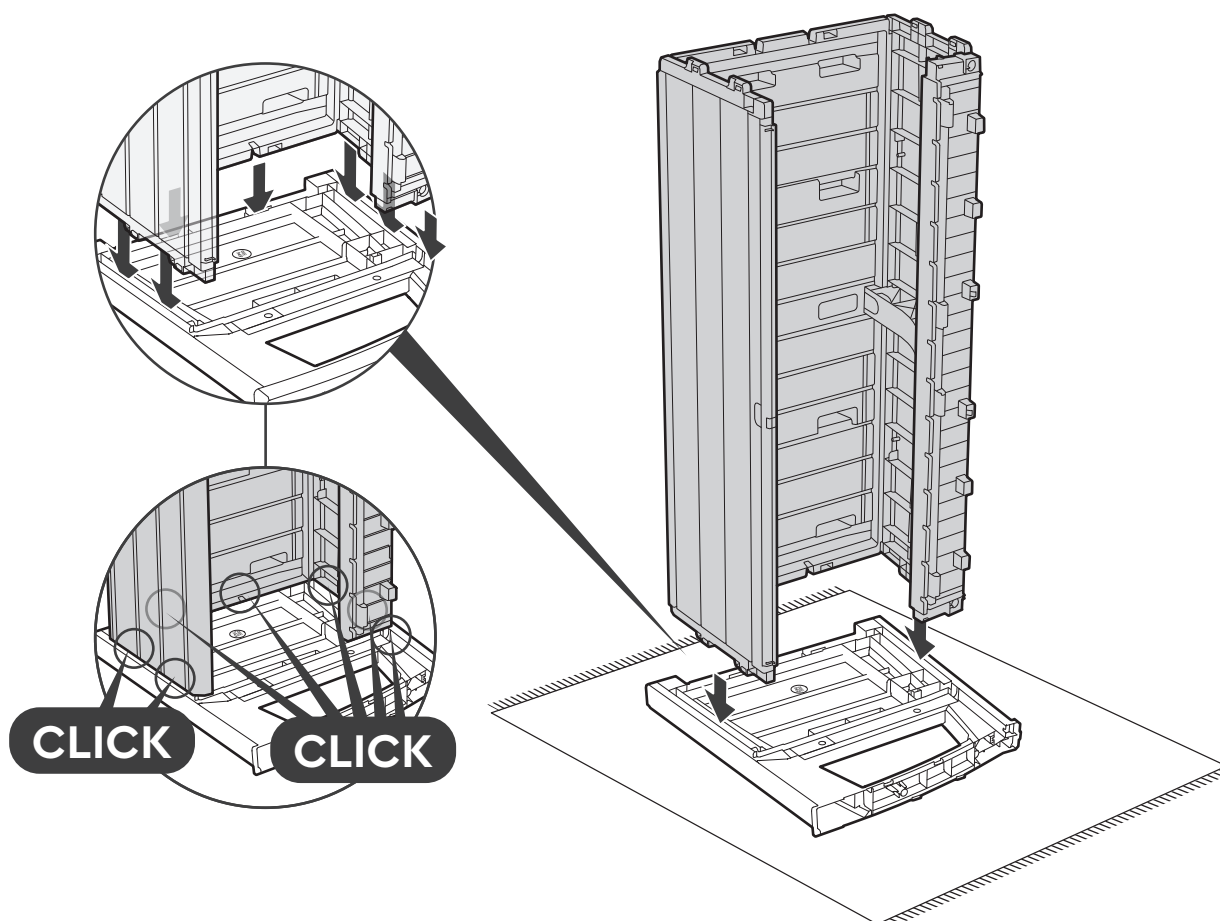

18



WSL (x1)

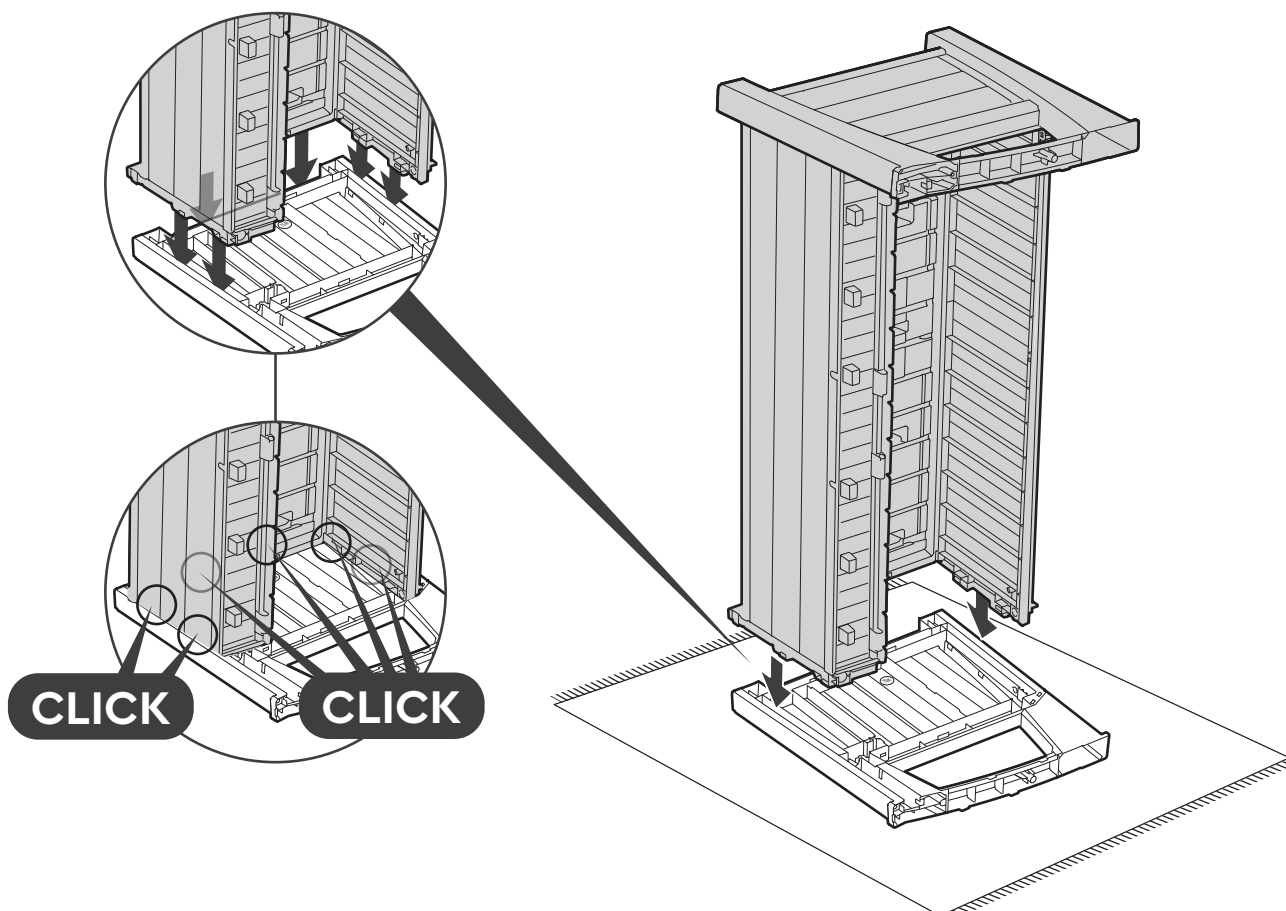

19



CP (x2)

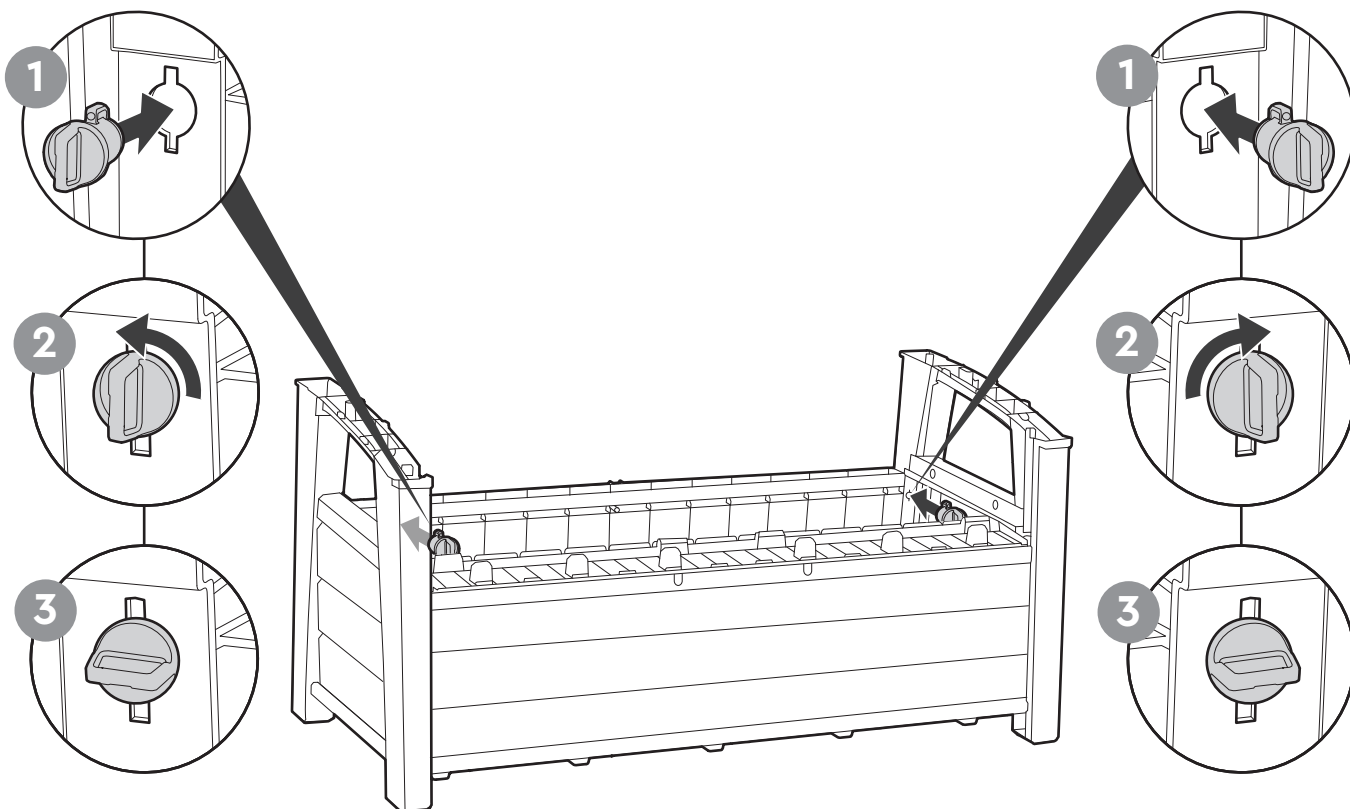

20



WBR (x1)

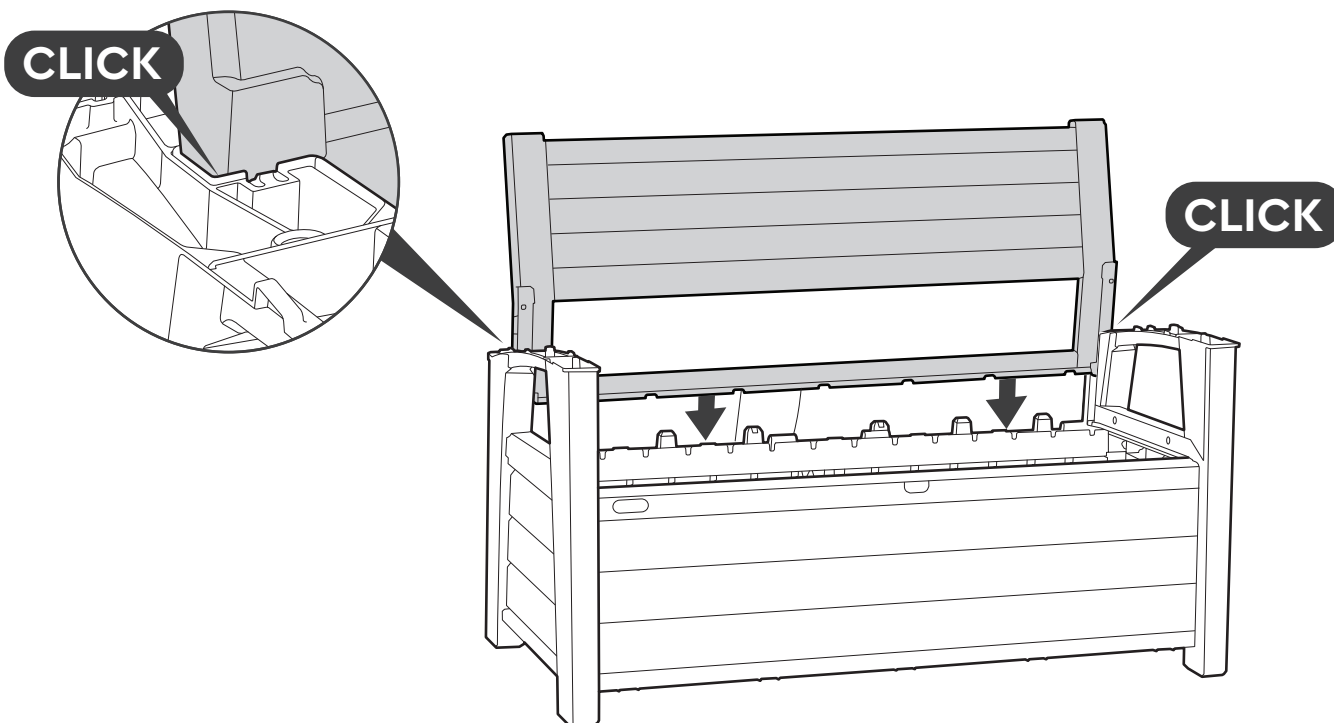

21

 S (x10)

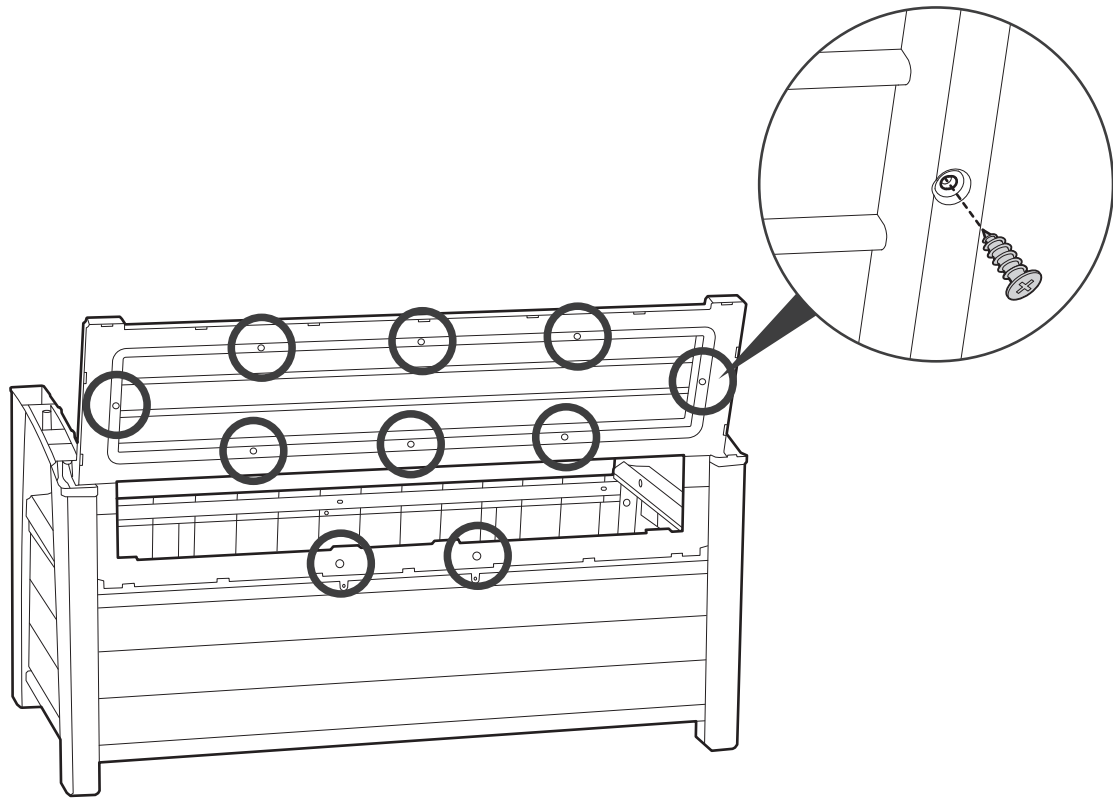

22



AL (x1)



AR (x1)

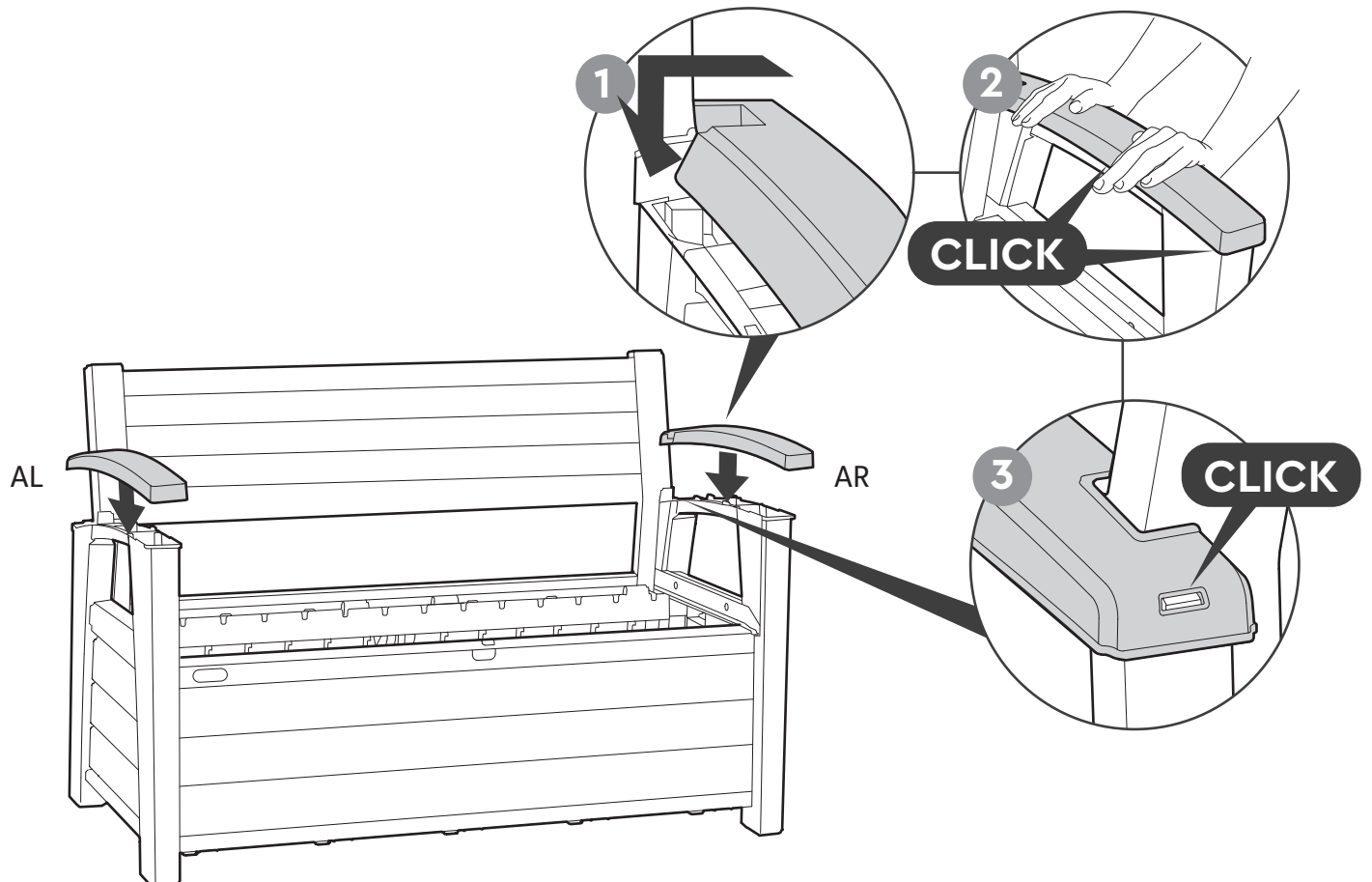

23



WLP (x1)



CBL (x1)



CFL (x1)



CBR (x1)



CFR (x1)

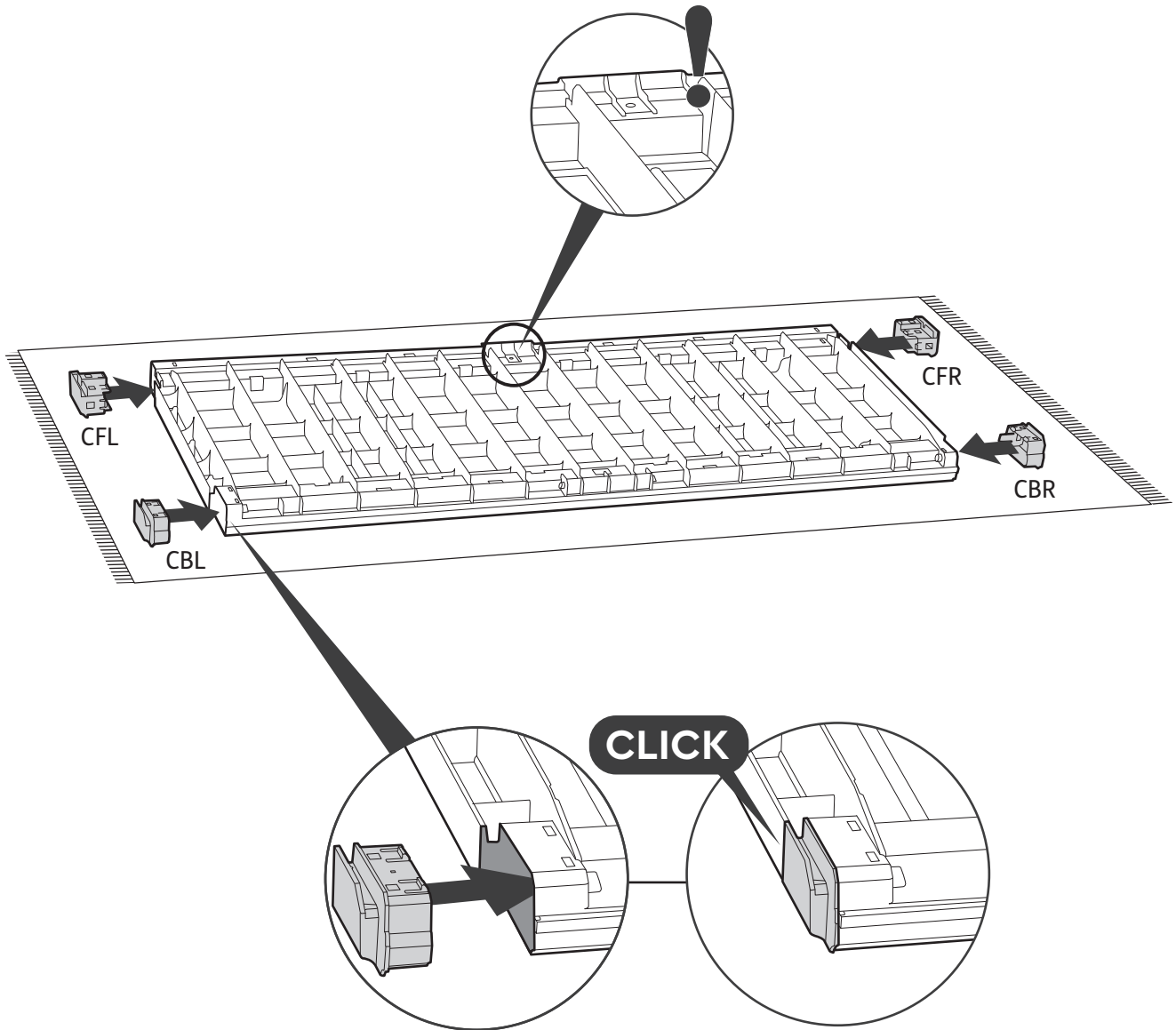

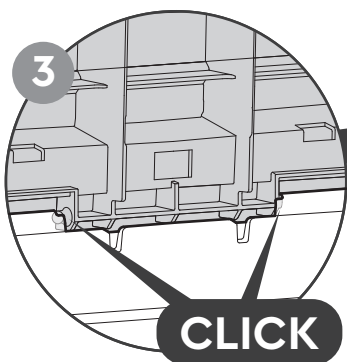
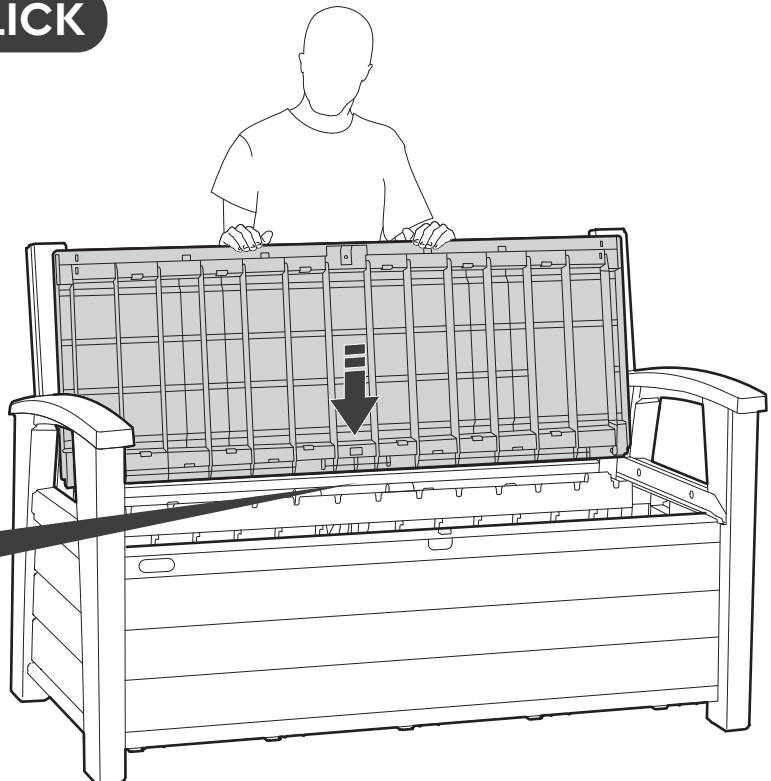
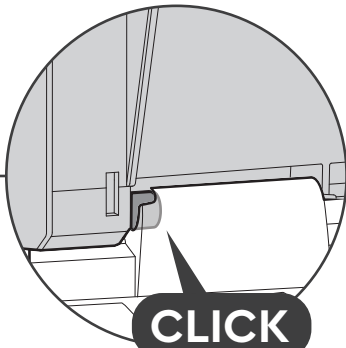
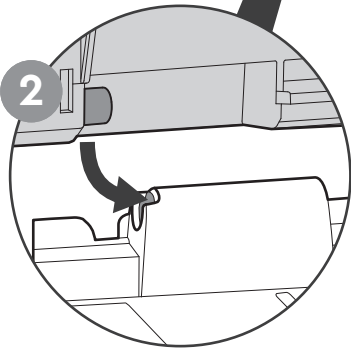
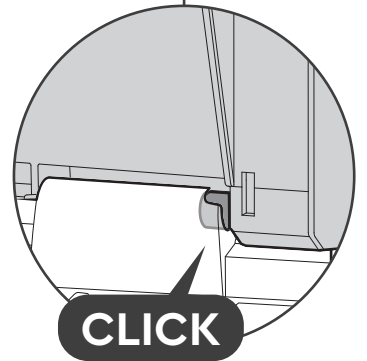
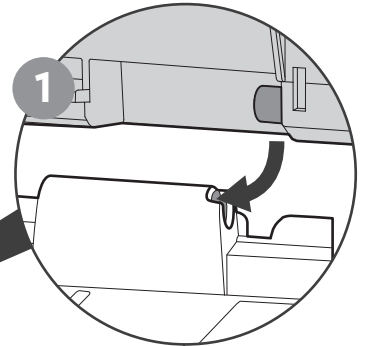
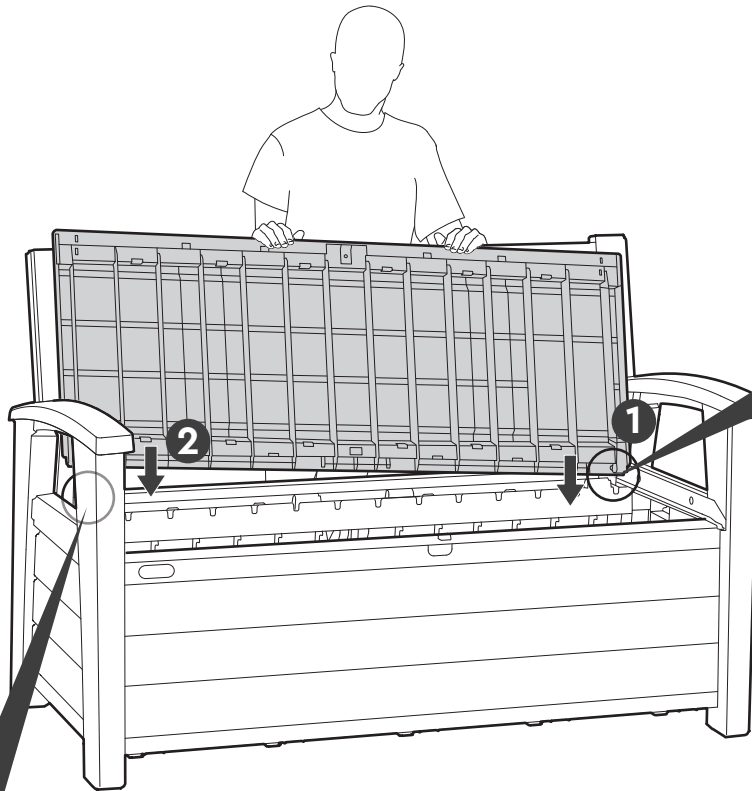
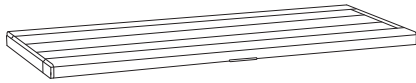

25



WL1 (x1)



WL2 (x1)



S (x2)

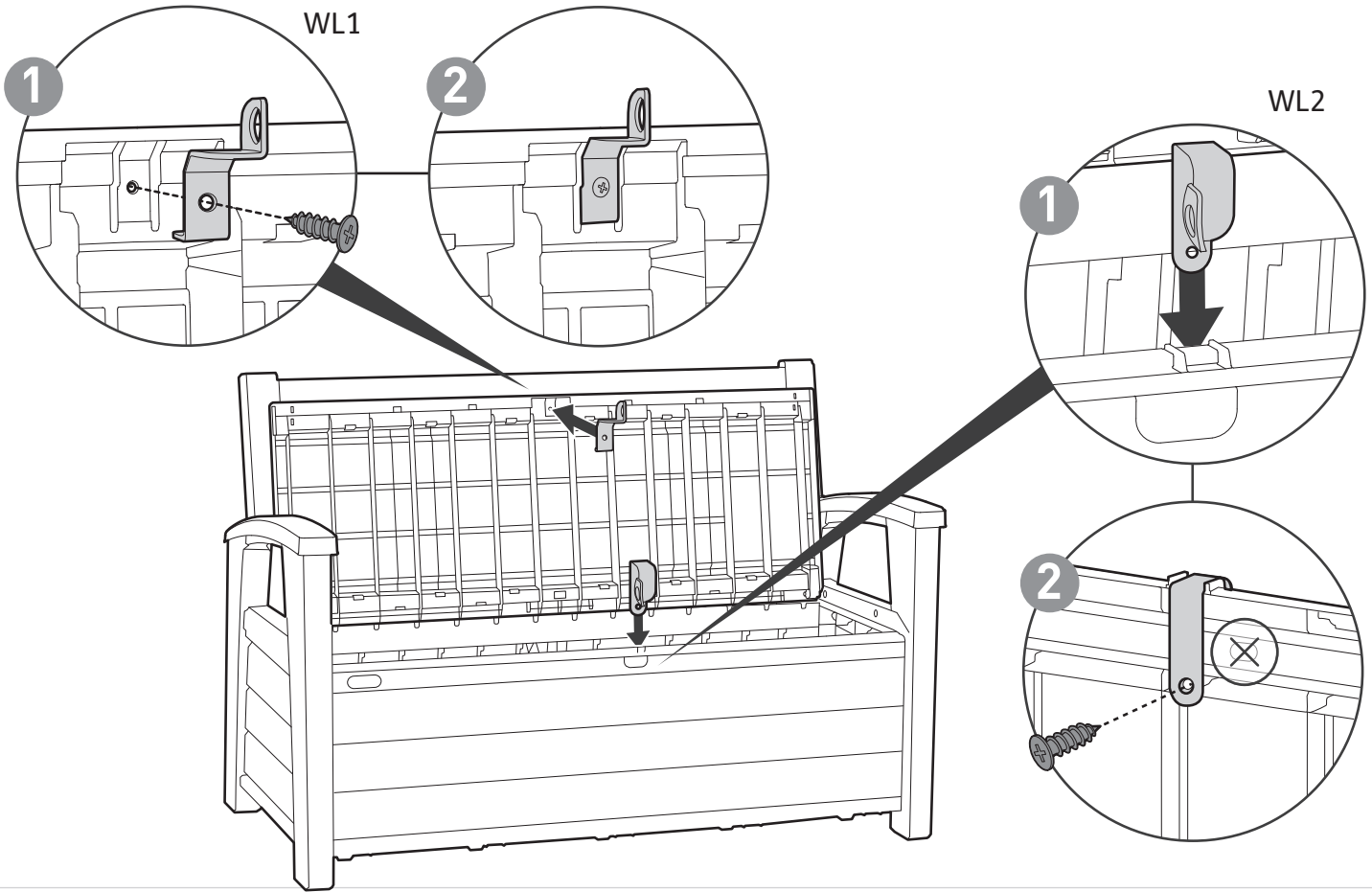

26

OPTION | OPTION | OPCIÓN | OPTION | OPTIE | OPZIONE | OPÇÃO | オプション | 옵션

It is strongly recommended to lock your box | Il est vivement recommande de verrouiller votre coffre | **Es wird wärmstens empfohlen, ihren aufbewahrungsbox abzuschließen** | Se recomienda muy especialmente cerrar el caja con candado | **Het is sterk aanbevolen het opbergbox op slot te doen** | Si raccomanda di chiudere contenitore magaz zino utilizzando l'apposito fermo | **Recomenda-se travar o seu abrigo.** | ロック可能 | 자물쇠 사용을 권장합니다.

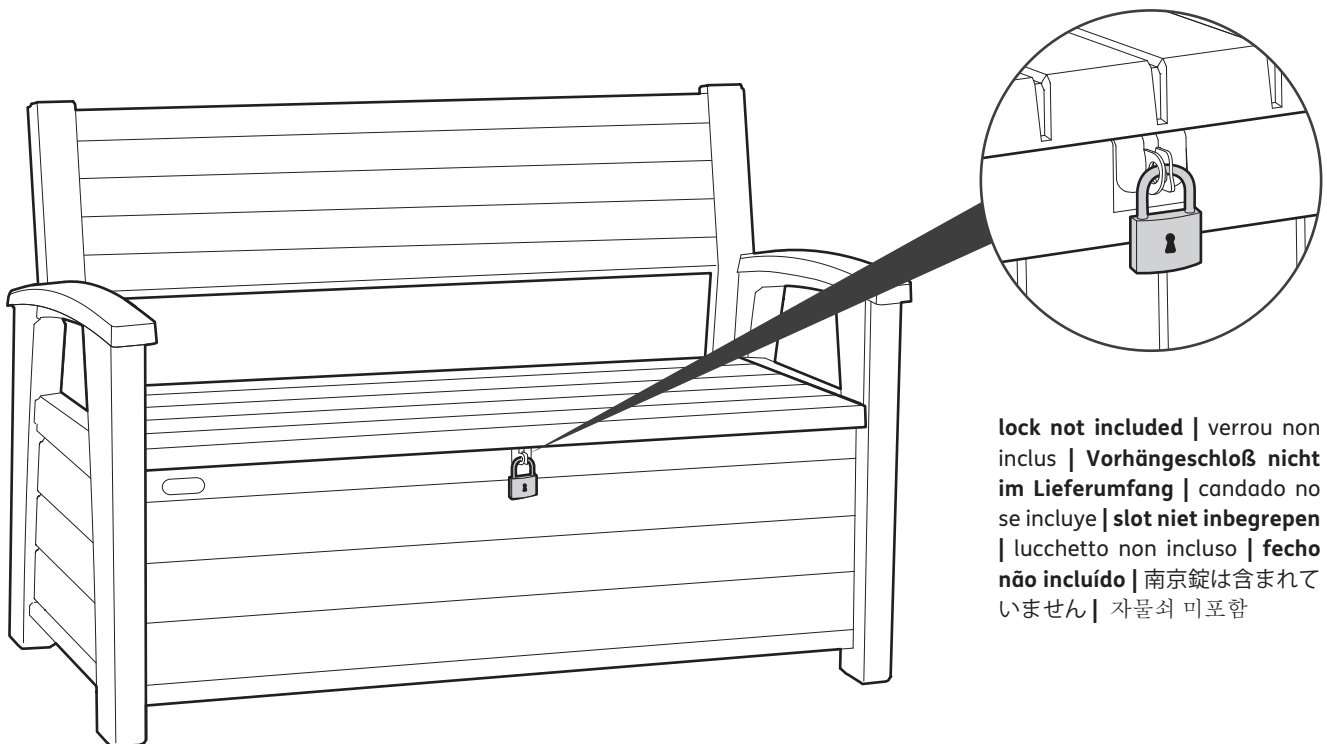

lock not included | verrou non inclus | **Vorhängeschloß nicht im Lieferumfang** | candado no se incluye | **slot niet inbegrepen** | lucchetto non incluso | **fecho não incluído** | 南京錠は含まれていません | 자물쇠 미포함

LIMITED 2-YEAR WARRANTY

Keter's renowned reputation for fine products is a result of its dedication and commitment to quality, design and innovation. The entire range of sheds and boxes is manufactured from high quality materials under rigorous control and supervision. In case a problem should occur, please address your claim to customer service either by phone or through our website: www.keter.com. The warranty is valid as of the date of purchase and a dated proof of purchase should be presented on request. Keter continuously tests its products for durability & stability and will replace, at its discretion, any product or part which fails due to structural defect or faulty workmanship, or which fails due to fading of color, for a 2-year period from the initial date of purchase. Damage caused by: use of force, incorrect handling, inappropriate use, neglect, commercial use or use other than for personal or household purposes; damages resulting from alteration, painting, or assembly not in accordance with the User's Manual and damages caused as a result of storage above the capacity load of the product, are excluded from this warranty. In addition, this limited warranty does not apply to damage resulting from exceptional wind effects (including, but not limited to, storms). After a claim has been settled, the guarantee period will continue to be counted and shall terminate upon its expiry date. Keter shall not be responsible for any damage caused by any reason whatsoever to goods stored in the Product. Please note that the products are produced from the finest raw materials, which are "clear": non-toxic and completely recyclable.

GARANTIE LEGALE DE CONFORMITE DE 2 ANS

La renommée croissante de Keter pour l'excellence de ses produits est le fruit de son engagement pour la qualité, la création et l'innovation. La gamme complète d'abris de jardin et de coffres a été fabriquée avec des matériaux de qualité, sous contrôle rigoureux. En cas de problème, veuillez adresser votre réclamation au service clientèle, par téléphone ou par le biais de notre site Internet: www.keter.com. La garantie prend effet à compter de la date d'achat, et une preuve d'achat datée devra être présentée sur demande. Keter teste constamment la solidité et la stabilité de ses produits et remplacera, si elle le juge nécessaire, tout produit ou partie de produit avéré défectueux du fait d'un défaut de fabrication ou de l'altération des couleurs, pendant une période de 2 ans à compter de la date d'achat. Les dommages causés par l'usage de la force, un maniement impropre, une utilisation inappropriée du produit, une négligence, un usage commercial ou un usage à des fins non privées ; de même que les dommages résultant d'une modification, d'une coloration ou d'un assemblage non effectué en conformité avec le manuel de l'utilisateur ; ainsi que les dommages causés par un stockage dépassant la capacité pondérale du produit, sont exclus de cette garantie. En outre, cette garantie limitée ne s'applique pas aux dommages résultant des effets exceptionnels du vent (y compris, mais pas limité aux tempêtes). Après avoir formulé votre réclamation, la période de la garantie restera valide jusqu'à sa date d'expiration. Keter décline toute responsabilité pour tout dommage de quelque nature que ce soit des biens emmagasinés dans le produit. À noter que les articles sont fabriqués avec des matières premières de qualité supérieure, déclarées "écologiques": non toxiques et entièrement recyclables.

2 JAHRES -GARANTIE MIT BESCHRÄNKTER HAFTUNG

Der gute Ruf von Keters Produkten begründet sich auf die Verpflichtung zu Qualität, Design und Innovation. Das gesamte Produkt-Spektrum der Gartenschuppen und Truhen wird aus hochwertigen Materialien unter strenger Kontrolle hergestellt. Sollte ein Problem auftreten, wenden Sie sich bitte telefonisch oder über unsere Homepage www.keter.com an unseren Kundendienst. Die Garantiezeit beginnt mit dem Kaufdatum. Bitte bewahren Sie die datierte Kaufquittung für eventuelle Rückfragen auf. Keter prüft seine Produkte ständig auf lange Lebensdauer und Stabilität. Sollten trotzdem Mängel auftreten, die auf Material- oder Verarbeitungsfehler zurückzuführen sind, oder sollte die Farbe verblassen, wird jedes mangelhafte Produkt oder Teil innerhalb eines Zeitraums von 2 Jahren ab dem Kaufdatum ersetzt. Von dieser Garantie ausgeschlossen sind Schäden, die durch Gewaltanwendung, unsachgemäße Bedienung oder Behandlung, Nachlässigkeit, kommerzielle Nutzung oder andere Nutzungen außer zu persönlichen Zwecken oder im Haushalt verursacht wurden. Schäden, die durch Veränderungen am Produkt, das Anstreichen oder unsachgemäße, vom Benutzerhandbuch abweichende Montage auftreten, ebenso wie Schäden, die auf das Überschreiten der zugelassenen Ladekapazität zurückzuführen sind, sind ebenfalls von der Garantie ausgeschlossen. Darüber hinaus deckt diese beschränkte Garantie Schäden, die auf außergewöhnliche Windbelastung (einschließlich, aber nicht nur Sturmschäden) zurückzuführen sind, nicht. Im Falle einer erledigten Reklamation wird die Garantiezeit weiterlaufen und der Garantieanspruch gilt nur bis zum ursprünglichen Ablaufdatum. Keter kann keine Verantwortung für Schäden an Waren übernehmen, die im Produkt gelagert werden, ganz egal aus welchen Gründen diese Schäden verursacht wurden. Bitte beachten Sie, dass unsere Produkte aus hochwertigen, umweltfreundlichen Rohmaterialien hergestellt werden und absolut ungiftig und vollständig recyclebar sind.

GARANTÍA LIMITADA POR 2 AÑOS

La afamada reputación que Keter ha ganado por sus excelentes productos es el resultado de su dedicación y compromiso hacia la calidad, el diseño y la innovación. La gama completa de cobertizos y cajas se fabrica con materiales de óptima calidad y bajo estrictos controles y supervisión. En caso de surgir algún inconveniente, rogamos tenga a bien elevar su queja al servicio de atención al cliente, ya sea vía telefónica o a través de nuestro sitio en la Web: www.keter.com. La garantía es válida a partir de la fecha de compra y, a solicitud, deberá presentarse un comprobante de compra con fecha. Keter pone a prueba sus productos en forma constante para determinar la durabilidad y estabilidad de los mismos. A criterio de Keter se reemplazará todo producto o parte del mismo que presente fallas como consecuencia de un defecto estructural o de mano de obra, o que se deteriore por decoloración, durante un período de 2 años, contados a partir de la fecha de compra inicial. Los daños causados por: el uso de la fuerza, la manipulación incorrecta, la utilización inadecuada, el descuido, el uso comercial o con un propósito diferente del personal o doméstico; los daños que resultaran de modificaciones, pinturas o armado no realizados de conformidad con las explicaciones del Manual de instrucciones y los daños causados por exceder la capacidad de carga de almacenamiento del producto, quedan excluidos de esta garantía. Además, esta garantía limitada no se aplica a los daños que resulten de los efectos de un viento excepcional (incluso, aunque no taxativamente, de las tormentas). Una vez que se haya remediado un reclamo, el período de garantía seguirá contando y finalizará en su fecha de vencimiento. Keter no asume responsabilidad alguna por ningún daño que hubiera sufrido cualquier artículo almacenado en el producto, cualquiera fuera su causa. Tenga en cuenta que los productos se fabrican con materias primas de excelente calidad, que son "ecológicas": es decir, no tóxicas y completamente reciclables.

2-JARIGE BEPERKTE GARANTIE

Keter heeft aan zijn toewijding en verplichtingen ten opzichte van kwaliteit, ontwerp en vernieuwing voor zijn prachtige producten, zijn vermaarde reputatie te danken. De gehele serie schuurtjes en dozen zijn, onder strenge controle en met toezicht van kwaliteitsmaterialen vervaardigd. In geval dat zich een probleem voordoet, dient u deze of via de telefoon, of via onze website, bij de klantenservice voor te leggen. Het adres voor onze website is: www.keter.com. De garantie is vanaf de aankoopdatum geldig en bij verzoek moet een aankoopbewijs met datum worden getoond. Keter test zijn producten continu op houdbaarheid & betrouwbaarheid en zal, gedurende een periode van 2 jaar vanaf de eigenlijke aankoopdatum, naar eigen goeddunken elk product of onderdeel met constructiefouten, of met kleurvervaging, vervangen. De garantie dekt niet de hierop volgende aangegeven schade: schade veroorzaakt door gewelddadig gebruik, onjuist gebruik, verwaarlozing, handelsgebruik anders dan persoonlijk of huishoudelijk gebruik, schade berokkent door aangebrachte veranderingen, verven of montage verricht op een andere wijze als beschreven wordt in de handleiding en schade veroorzaakt door het opslaan boven het vermogenonderdeel van het product. Daarnaast is deze beperkte garantie niet van toepassing op schade die ontstaan is als resultaat van buitengewone windeffecten (inclusief, maar niet beperkt tot, stormen). Nadat een claim is gevestigd, gaat de garantieperiode gewoon door tot de vervaldatum, waarop het zal worden beëindigd. Keter kan niet aansprakelijk worden gesteld voor enige schade die door een of andere reden is ontstaan tijdens het opslaan van het product. Denk eraan dat de producten van de fijnste ruwe materialen zijn gemaakt die geheel "zuiver" zijn: niet giftig en geheel recyclebaar.

GARANZIA LIMITATA DI 2 ANNI

L'ottima reputazione di cui gode Keter per i suoi prodotti è il risultato di una dedizione e di un impegno costante verso la qualità, il design e l'innovazione. L'intera gamma degli armadietti e dei box viene prodotta con materiali di prima qualità, sotto un controllo e una supervisione rigorosi. Se dovesse presentarsi un problema, presentare reclamo al servizio d'assistenza, per telefono o attraverso il nostro sito Web: www.keter.com. La garanzia è valida a partire dalla data di acquisto e su richiesta deve essere presentata una prova di acquisto datata. Keter tiene continuamente sotto controllo la durevolezza e la solidità dei suoi prodotti ed è pronta a sostituire, a sua discrezione, qualsiasi prodotto o parte di esso presentante un'alterazione provocata da un difetto strutturale o dal processo di produzione, o un'alterazione causata da un colore sbiadito, per un periodo di 2 anni a partire dalla data di acquisto. I danni causati da: uso di forza, uso non corretto, utilizzo inappropriato, negligenza, uso commerciale o uso diverso da quello personale o per fini domestici; danni derivanti da alterazione, pittura, o montaggio non eseguito in conformità con il manuale d'istruzioni; e danni provocati in conseguenza di condizioni di magazzinaggio eccedenti la capacità di carico del prodotto, sono esclusi dalla presente garanzia. Inoltre, questa garanzia limitata non si applica ai danni causati dagli effetti di condizioni meteo eccezionali (inclusi, ma non limitati ai temporali). Dopo aver stabilito un reclamo, il periodo di garanzia continuerà ad essere calcolato e terminerà alla sua data di scadenza. Keter non sarà ritenuta responsabile per danni causati da una qualunque ragione ai beni contenuti nel Prodotto. Si noti che i prodotti sono costruiti dalle migliori materie prime, che sono "sicure": non tossiche e completamente riciclabili.

GARANTIA LIMITADA DE 2 ANOS

A célebre reputação da Keter pelos seus produtos distintos é resultante da sua dedicação e compromisso com a qualidade, o design e a inovação. Toda a gama de abrigos de jardim e caixas é produzida com materiais de elevada qualidade que são sujeitos a um controlo e supervisão rigorosos. Se ocorrer algum problema com o produto, faça a sua reclamação junto do serviço de apoio ao cliente, através do telefone ou do nosso site: www.keter.com. A Garantia é válida a partir da data de compra e deve ser apresentada uma prova de compra, se solicitado. A Keter testa continuamente os seus produtos quanto a durabilidade e estabilidade, e procederá, da forma que achar conveniente, à substituição de qualquer produto ou parte do mesmo que esteja danificada como consequência de defeito na estrutura, defeito de fabrico ou descoloração do produto, durante um período de 2 anos, a contar da data da compra. Os danos causados pelo uso da força, manuseamento incorrecto, utilização indevida, negligência, uso comercial ou outro uso que não o relacionado com fins domésticos ou pessoais, danos causados por alteração, pintura ou montagem que não sejam em conformidade com o Guia do Utilizador, assim como danos causados pelo armazenamento de artigos acima da capacidade de carga do produto, estejam excluídos desta garantia. A lém disso, esta garantia limitada não abrange danos resultantes dos efeitos de ventos anormais (incluindo, entre outros, tempestades). A pós a resolução de uma reclamação, o período da garantia continuará a ser contado e deve terminar após o fim da data de validade. A Keter não será responsável por nenhuns danos causados por qualquer motivo nos bens armazenados no Produto. Note que os produtos são produzidos a partir das melhores matérias-primas, as quais são "limpas": não-tóxicas e totalmente recicláveis.

2년 품질보증

KETER의 좋은 제품에 대한 명성은 품질과 디자인 혁신을 위해 헌신한 결과입니다.

모든 케터 제품은 엄격한 관리 아래 무독성 고품질의 재료로 제작하고 있으며 재활용이 가능합니다.

구매한 날로부터 2년 품질보증을 하고 있으며 제품에 문제가 있을 경우 고객센터로 연락주시기 바랍니다.

케터는 제품에 문제가 없는지 지속적으로 테스트 하고 있습니다.

물리적 충격, 오남용, 방치, 개조, 도색, 잘못된 조립, 중량 초과, 강풍/태풍 등의 모든 자연재해는 품질보증에서 제외됩니다.

2年間限定保証

品質、デザイン、革新へのこだわりがKeter社製品に対する高い評価の結果です。物置やその他収納製品は厳格な管理と監督の下で高品質素材から製造されています。問題が発生した場合は、カスタマーサービスの電話番号又はメールアドレスまでご連絡下さい。

保証は購入日から有効であり、日付掲載の付いた購入証明を必要に応じてご提示下さい。

Keterは製品の耐久性と安定性を継続的に検証しています。規定により当初から2年間、製造上の欠陥や仕上がりの欠陥、色あせなどによって引き起こされる損傷不良製品または部品を交換します。

以下の場合、保証適用外となります。

強制、不適切な取り扱い、不適切な使用、不注意、商業的使用、また個人的、家庭的な目的の容量負荷を超える保管の結果として生じた損傷。

さらに、この限定保証は例外的な風の影響（暴風雨を含む）に起因する損傷には適用されません。

クレームが解決された後保証期間は満了期日まで継続します。

製品の中に保管されている商品に何らの理由で生じた損傷につきましてKeterは一切責任を負えません。

この商品は最高級、無毒性、完全に再利用（リサイクル）可能な原材料から製造されています。

CARE & SAFETY

In case of fire, do not attempt to extinguish any burning polypropylene with water.
It is of utmost importance to assemble all of the parts according to the directions. Do not skip any step.
Wear safety goggles and always follow the manufacturer's instructions when using power tools.
Using a stiff brush or abrasive cleaner could damage the box. Clean with water and mild soap.
Hot items such as recently used grills, blowtorches, etc., must not be stored in the box.
Not designed for carrying items.
After rain, wipe box with cloth before opening.
Unsuitable for storage of flammable or corrosive substances.
Do not stand on lid.
Not intended for use by children. This is not a toy box.

PRÉCAUTIONS ET SÉCURITÉ

En cas d'incendie, ne pas tenter d'éteindre le polypropylène brûlé avec de l'eau.
Il est impératif de monter toutes les parties selon les instructions. Ne pas omettre une quelconque étape.
Portez des lunettes de protection et suivez toujours les instructions du fabricant lorsque vous utilisez des outils électriques.
L'utilisation d'une brosse dure ou d'un nettoyant abrasif pourrait endommager la boîte. Nettoyer avec de l'eau et du savon doux.
Des articles chauds, tels que des grills non refroidis, des chalumeaux, etc., ne doivent pas être entreposés dans la boîte.
Non conçue pour le transport d'objets.
Après la pluie, essuyer la boîte avec un chiffon avant de l'ouvrir.
Ne convient pas pour le stockage de substances inflammables ou caustiques.
Ne pas se tenir debout sur le couvercle.
Non destiné à être utilisé par des enfants. Ceci n'est pas un coffre à jouets.

PFLEGE - UND SICHERHEITSHINWEISE

Im Brandfall sollten Sie nicht versuchen, brennendes Polypropylen mit Wasser zu löschen.
Es ist äußerst wichtig, dass alle Teile der Anleitung zufolge montiert werden. Bitte lassen Sie keine Schritte aus.
Tragen Sie beim Gebrauch von Elektrowerkzeugen eine Schutzbrille und folgen Sie stets der Anleitung des Herstellers.
Die Verwendung einer harten Bürste oder eines Scheuermittels könnte das Gehäuse beschädigen. Reinigen Sie es mit Wasser und milder Seife.
Noch heiße Gegenstände wie Grillgeräte, Fackeln usw. dürfen nicht in der Truhe aufbewahrt werden.
Nicht zum Transport von Gegenständen geeignet.
Nach einem Regen sollte die Truhe vor dem Öffnen mit einem Tuch abgewischt werden.
Nicht zur Aufbewahrung von entzündbaren oder ätzenden Mitteln vorgesehen.
Bitte nicht auf den Deckel treten.
Nicht für den Gebrauch durch Kinder bestimmt. Dies ist keine Spielzeugkiste.

CUIDADO Y SEGURIDAD

En caso de incendio, no intente extinguir polipropileno en llamas con agua.
Es de suma importancia armar todas las partes de acuerdo con las instrucciones. No omita ninguno de los pasos.
Use anteojos protectores; al usar herramientas eléctricas, siga siempre las instrucciones del fabricante.
El uso de un cepillo duro o un limpiador abrasivo podría dañar la caja. Limpiar con agua y jabón suave.
Los objetos calientes - como por ejemplo, las parrillas recién usadas, sopletes, etc. - no deben guardarse en el arcón.
No está diseñado para el traslado de objetos.
Después de una lluvia, limpiar el arcón con un paño antes de abrirlo.
No es apropiado para el almacenamiento de sustancias inflamables o cáusticas.
No pararse sobre la tapa.
No debe ser utilizada por menores jóvenes. No es una caja de juguetes.

ZORG EN VEILIGHEID

In geval van brand NIET proberen om brandend polypropyleen met water te blussen.
Het is uitermate belangrijk alle onderdelen volgens de richtlijnen te monteren. Sla geen van de stappen over.
Draag een veiligheidsbril en volg altijd de instructies van de fabrikant als u elektrisch gereedschap gebruikt.
Het gebruik van een harde borstel of een schurend reinigingsmiddel kan de doos beschadigen. Reinig met water en een zachte zeep.
U mag geen warme voorwerpen zoals een pas gebruikte grill, soldeerlamp, enz. in de kist opslaan.
De kist is niet ontworpen om voorwerpen te dragen.
Nadat het heeft geregend, dient u de kist met een doek af te vegen alvorens u deze opent.
Ongeschikt voor het opslaan van brandbare of gevaarlijke materialen.
U mag niet op de klep staan.
Niet bedoeld voor gebruik door kinderen. Dit is geen speelgoeddoos.

MANUTENZIONE E SICUREZZA

In caso di incendio, non usare l'acqua per spegnere il fuoco sugli oggetti in polipropilene.
È della massima importanza assemblare tutte le parti seguendo accuratamente le istruzioni. Non saltare nessuno dei passaggi.
Indossare occhiali di sicurezza e seguire sempre le istruzioni del produttore durante l'utilizzo di strumenti elettrici.
L'utilizzo di una spazzola rigida o di un detergente abrasivo potrebbe danneggiare la scatola. Pulire con acqua e sapone neutro.
Non riporre nell'armadietto elementi roventi, come una graticola usata di recente, un bruciatore di saldatura, ecc.
L'armadietto non è stato progettato per sorreggere altri utensili.
Dopo la pioggia, asciugare il contenitore con un panno prima di aprirlo.
Non adatto per la conservazione di sostanze infiammabili o corrosive.
Non appoggiarsi al coperchio.
Non destinata all'utilizzo da parte dei bambini, non si tratta di una scatola giocattolo.

MANUTENÇÃO E SEGURANÇA

Em caso de incêndio, não tente apagar material de polipropileno em combustão com água.
É de extrema importância que monte todas as partes de acordo com as instruções. Não omita nenhum passo.
Utilize sempre óculos de proteção e siga as instruções do fabricante quando utilizar ferramentas elétricas.
O uso de escovas de cerdas rígidas ou limpador abrasivo pode danificar a caixa. Limpe com água e sabão neutro.
Elementos que estejam quentes, como, por exemplo, grelhas utilizadas recentemente, maçaricos, etc. não devem ser guardados na caixa.
Este produto não foi concebido para transportar artigos.
Se apanhar chuva, seque a caixa com um pano antes de a abrir.
Não deve ser utilizado para guardar substâncias inflamáveis ou corrosivas.
Não se apoie na tampa da unidade.
Não deve ser utilizado por crianças. Esta não é uma caixa de brinquedo.

주의사항

불이 났을 경우 물이 아닌 소화기나 다른 도구를 사용하십시오.
반드시 조립설명서대로 조립하시고 어떤 단계도 건너뛰지 마십시오.
안전을 위해 고글과 장갑을 착용하십시오.
거친 도구로 청소하지 마십시오.
방금 사용한 토치나 그릴 등 뜨거운 물건은 보관하지 마십시오.
이동형 제품이 아니며 무거운 물건을 넣은 채로 제품을 들지 마십시오.
비가 온 후에는 뚜껑을 열기 전에 빗물을 닦아주십시오.
휘발성이나 부식성 물건을 보관하지 마십시오.
질식의 위험이 있으므로 어린이가 제품 안으로 들어가지 않도록 하십시오.

お手入れ、安全について

火災が発生した場合は、燃えているポリプロピレンを水で消火しないで下さい。
取説上指示に従って全ての部品を組み立てることが最も重要です。順番をスキップしないで下さい。
電動工具を使用する際、安全ゴーグルを着用し常にメーカーの指示に従って下さい。硬いブラシまたは研磨剤、クリーナーを使用しますと商品が損傷する可能性があります。
使用後のBBQグリル、トーチランプなどの高温アイテムは商品の中に保管しないで下さい。
物を運ぶために設計されている商品ではありません。
雨が降った後、布で商品を拭いてから開けて下さい。
可燃性または腐食性物質の保管はしないで下さい。
蓋の上に立たないで下さい。
窒息の危険を防ぐために、子供が箱の中で遊ばせないで下さい。

조립을 하시기 전에 반드시 읽어 주시기 바랍니다.

땅 다듬기

창고를 지으실 곳은 반드시 수평인 곳으로 신중하게 선택하시길 바라며 나무, 콘크리트 바닥을 권장합니다.

1. 주변의 돌맹이들을 모두 치워주십시오.
2. 모든 식물의 뿌리와 줄기 및 기타 부스러기, 파편을 제거해 주십시오.
3. 갈퀴질을 하고 길고 납작한 물건을 이용하여 지면을 평평하게 해주십시오.

품질보증

KETER 조립식 창고의 경우 재료 또는 제작의 결함은 조립설명서에 나와 있는 기간만큼 보증을 해드립니다 KETER의 좋은 제품에 대한 명성과 평판은 품질, 디자인과 혁신을 위해 헌신한 결과입니다. 만약 문제가 발생했을 경우 전화나 메일을 통해 연락을 주시면 감사하겠습니다.

※다음과 같은 경우에는 보증 책임을 지지 않습니다.

- 개인용이나 가정용으로 사용하지 않고 상업적 목적, 기타 목적으로 사용했을 경우
- 무력의 사용, 잘못된 사용, 부적절한 사용, 오용, 방치, 사고, 다른 물체와의 충돌, 고의적인 파괴, 오염, 부적합한 바닥에 조립한 경우, 개조, 도장, 색바림, 제품의 한계 용적 초과, 조립설명서에 따라서 조립하지 않았을 경우
- 우박, 폭풍, 태풍, 강풍, 대설, 눈보라, 홍수, 화재 등의 자연재해로 인해 피해가 생긴 경우
- 구성 요소, 부품이 KETER에서 제공한 것이 아닌 경우

주의사항

- 반드시 조립설명서 대로 조립하시고 어떤 조립단계도 건너뛰지 마십시오.
- 창고를 조립하기 전에 신고 및 허가가 필요할 수 있으니 해당 지역의 공공기관에 문의하시기 바랍니다.
- 지속적으로 확인하고 관심을 기울여 주신다면 창고를 안전하고 건실하게 오랫동안 사용하실 수 있습니다.
- 전동공구를 사용하실 때에는 반드시 안전고글을 착용하시고 조립설명서 대로 따라 주십시오.
- 정기적으로 나사가 단단히 조여졌는지 확인하여 주십시오.
- 창고를 청소하실 때에는 정원용 호스와 자극이 덜한 세제를 사용하여 주십시오.
- 뾰족한 솔이나 연마용 청소도구를 사용하면 창고가 마모 될 수 있습니다.
- 부품을 매달아 두거나 끌지 마시고 벽에 기대어 놓지 마십시오.
- 무거운 부품을 벽에 기대어 놓을시 찌그러지거나 뒤틀릴 수 있습니다.
- 물품을 선반의 가장자리에 보관하지 마시고 지붕에 세워 놓지 마십시오.
- 창고는 오직 보관용으로 사용하시고 주거용으로는 사용하지 마십시오.
- 방금 사용한 그릴이나 휴대용가스스토치 등 뜨거운 제품은 창고에 보관하지 마십시오.
- 바람의 피해를 방지하기 위하여 문은 항상 닫아주시고 필요시 잠금장치를 설치해 주시기 바랍니다.
- 바람의 방향은 창고의 위치를 정할 때 매우 중요한 요소입니다. 창고가 바람에 덜 노출되도록 해주십시오.
- 지붕 위 많은 양의 눈은 창고에 피해를 줘 위험할 수 있으므로 지붕 위의 눈과 나뭇잎은 항상 치워주시기 바랍니다.
- 참고 : 제품의 다양성으로 부품의 크기가 기존에 나와 있는 치수와 약간 다를 수 있습니다.

모든 장비를 최대한 안전하게 하려고 매번 시도하고 있기는 해도 부상의 위험이 없는 것은 아닙니다. 사용자는 이 제품의 사용으로 인한 부상의 위험을 감수하여야 하며 항상 조심하시기 바랍니다. 별도의 통보 없이 제품의 생산이 중단되거나 색상의 변화가 있을 수 있습니다. 저희 제품은 독성이 없고 완전히 재활용이 가능한 최상의 재료로 만들어 지고 있습니다. 보증 책임의 조건과 기간에 따라 제품에 문제가 있을 경우 수리, 복구, 교환이 가능합니다.

조립식 창고의 경우 국내 건축법상 해당 제품은 가설 건축물 또는 농막에 해당한다고 볼 수 있습니다. 대지, 전, 담, 임야 등 지상에 설치 할 경우 해당 공공기관 건축과에 문의하시어 신고를 하셔야합니다. 신고비용은 없으며 인터넷이나 공공기관에 비치된 신고서를 작성하여 제출하시기 바랍니다. 농막의 경우도 농지전용 절차 없이 설치가 가능하나 농업경영에 이용하는 토지에 설치하는 시설일 것, 주거목적이 아닌 농기자재 및 농약 등의 보관, 작업 중 휴식 및 간이 취사 시설일 것, 전기·수도·가스 등 간선공급시설을 요하지 않을 것 등의 요건을 갖추어야 하며 농막 역시 신고 절차를 밟아야 합니다. 옥상의 경우 어떠한 가설건축물이든지 증축에 해당되어 반드시 허가를 받으셔야 합니다. 그러나 저희 제품은 재질이 합성수지이므로 허가 가능 재질인지 설치 전 꼭 해당 건축과에 문의하시기 바랍니다. 각 지역의 특성상 유권해석이 상이하기 때문에 법적으로 더 자세한 내용을 알고 싶으시다면 설치 전에 각 지역 공공기관의 건축과나 해당부서로 문의하시기 바랍니다.

Customer Service:

Keter Korea

TEL : 031-767-2492

FAX : 031-765-2497

Email: info@keter.co.kr

Address : 40, Dunteo-ro, Majang-myeon, Icheon-si, Gyeonggi-do

IF THERE ARE MISSING OR BROKEN PARTS, PLEASE DO NOT RETURN THE PRODUCT TO THE STORE.
PLEASE ACCESS OUR WEBSITE WWW.KETER.COM, OR CONTACT CUSTOMER SERVICE AT YOUR COUNTRY/REGION:

S'IL Y A DES PIÈCES MANQUANTES OU CASSÉES, NE RETOURNEZ PAS LE PRODUIT AU MAGASIN.
VEUILLEZ ACCÉDER À NOTRE SITE WEB WWW.KETER.COM OU CONTACTER LE SERVICE CLIENT DE VOTRE PAYS/RÉGION:

SI HUBIERA ALGUNA PARTE FALTANTE O DAÑADA, NO DEVUELVA EL PRODUCTO A LA TIENDA.
ACCEDA A NUESTRA WEB WWW.KETER.COM O CONTACTO CON EL SERVICIO DE ATENCIÓN AL CLIENTE DE SU PAIS/REGIÓN:

BITTE BRINGEN SIE IHR PRODUKT NICHT GLEICH ZUM LADEN ZURÜCK, FALLS TEILE FEHLEN ODER DEFEKT SIND.
BITTE LOGGEN SIE IN UNSERE WEBSITE EIN ODER WENDEN SIE SICH AN UNSEREN KUNDENSERVICE:

IN GEVAL VAN ONTBREKENDE OF BESCHADIGDE ONDERDELEN KUNT U GEBRUIK MAKEN VAN DE KETER ONDERDELENSERVICE
GA NAAR ONZE WEBSITE WWW.KETER.COM OF NEEM CONTACT OP MET DE KLANTENSERVICE VIA ONDERSTAANDE
CONTACTGEGEVENS:

IN CASO DI PARTI MANCANTI O ROTTE, PREGHIAMO DI NO RESTITUIRE IL PRODOTTO AL NEGOZIO.
CHIEDIAMO CORTESEMENTE DI ACCEDERE AL NOSTRO SITO WEB WWW.KETER.COM O, CONTATTARE IL SERVIZIO CLIENTI DEL
VOSTRO PAESE:

SE EXISTEREM PEÇAS DANIFICADAS OU PARTIDAS POR FAVOR NÃO EFECTUAR DEVOUÇÃO À LOJA.
ACEDA AO NOSSO SITE WWW.KETER.COM OU AO NOSSO SERVIÇO DE PÓS VENDA:

US / Canada: (EN/FR)
Tel: +1-888-374-4262
keter.com/en-us/contact-us.html
Email: NACS@keter.com

UK: (EN)
Tel: +44-121-506-0008
Email: CSUK@keter.com
Keter UK Ltd
16 Great Queen Street, Covent
Garden, London, WC2B 5AH
Mon - Fri | 8am - 4pm

Israel:
Tel: 1-700-70-6015

Switzerland:
Tel: +41-62-767-00-50
Email: info@neogard.ch

France:
Votre produit ayant été acheté dans
une enseigne, qu'elle soit physique ou
sur internet, c'est auprès de cette
enseigne que vous devez faire votre
demande SAV.

Australia:
Tel: 03 9544 6999
Email: keteraus@keter.com
28 Buckland St,
Clayton, Victoria 3168
Mon - Fri | 9am - 5pm

Iberia:
Email: spvketer@carcaba.com

South Africa:
Email: info@keter.co.za

Spain: (SP)
Tel: +34-876-14-13-93
www.keter.com/es-es/contact-us.html
E-mail: Service.Iberia@keter.com
Mon - Fri | 8am - 5pm

Italy:
Tel: +39 0422 745900
Email: Servizio.clienti@keter.com

고객센터:
Tel: 031-767-2492
Email: info@keter.co.kr
월 - 금 | 9:00am - 05:30pm

株式会社 藤栄
〒152-0032 東京都目黒区平町1-2-2
TEL : 03-3723-6525

Poland:
Tel: +48 59 84 19 892
Email: Service.poland@keter.com

Hungary:
Tel: +36 52 565 920
Email: Service.hungary@keter.com

Nordics:
Tel: +48 59 84 19 892
Email: Service.nordic@keter.com

Germany/Austria:
Tel: +49 (3) 222-10-96-42-1
Email: service@keter-ersatzteile.de

NL/BE/LUX:
Email: Klantenservice@keter.com

WWW.KETER.COM

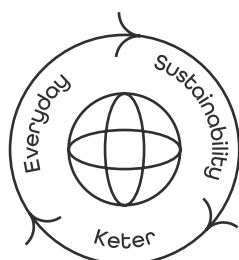

KETER

Le développement durable au
quotidien | Sostenibilidad día a día



Designed to Last | Conçu pour durer | Diseñado
para durar | Auf Langlebigkeit ausgelegt |
Duurzaam ontworpen | Progettato per durare |
Projetado para durar



Recyclability & Recycling | Recyclabilité et
Recyclage | Reciclabilidad y reciclable | recyclefähig
& recycelt | Recyclebaarheid & recycling |
Riciclabilità e Riciclo | Reciclabilidade e Reciclagem



Community | Communauté |
Comunidad | Community |
Community | Comunità | Comunidade



Responsible Manufacturing | Fabrication responsable |
Producción responsable | Verantwortungsbewusste
Herstellung | Verantwoorde productie |
Produzione responsabile | Fabricação responsável

Made in Israel by | Fabriqué en Israël par | Hecho en Israel por | Hergestellt in Israel von | Gemaakt in Israël door |
Realizzato in Israele da | Fabricado em Israel por Keter Home and Garden Products Ltd., 1 Sapir St. Industrial Area,
Herzliya 4685205, Israel



<https://quefairedemesdechets.fr>